

STIHL FS 120, 200, 250

(4134)

Spare Parts List

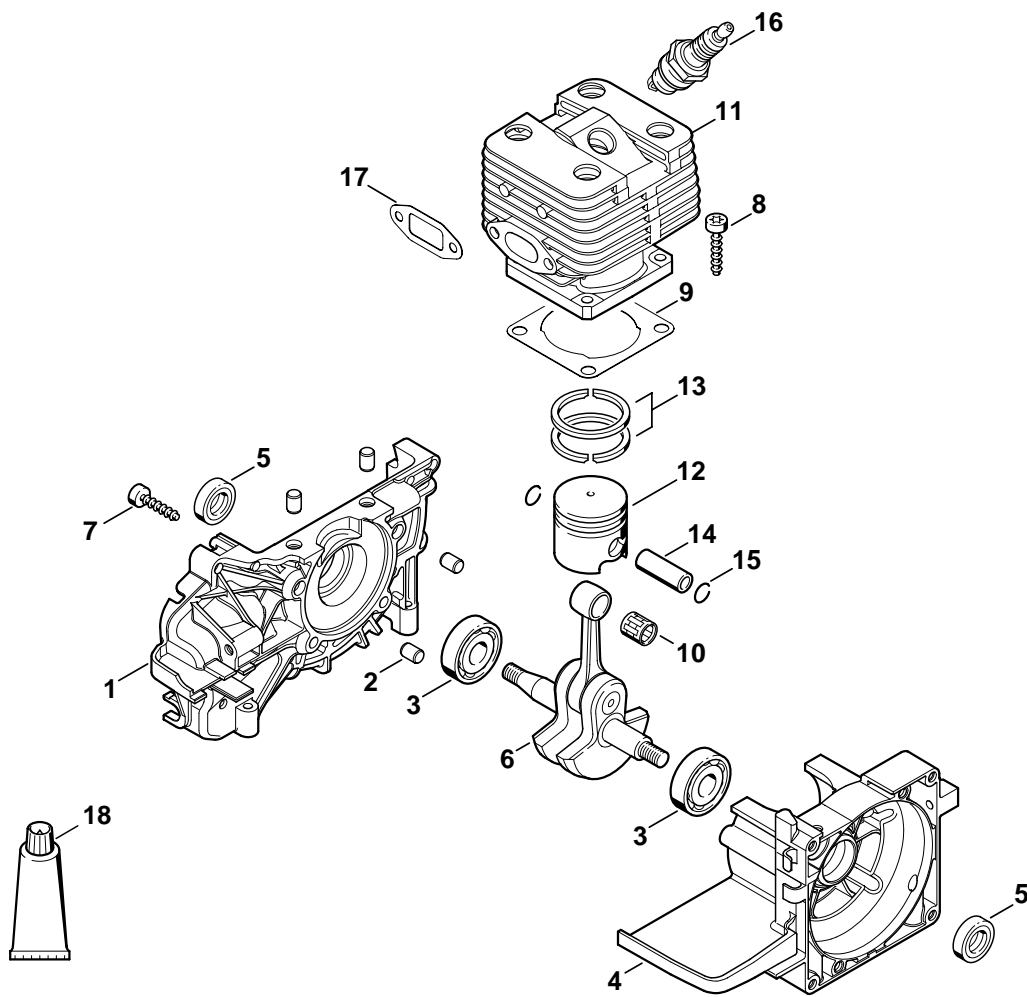

250ET019 GM

Illustration A

Kurbelgehäuse, Zylinder
FS 120, 120 R

Crankcase, Cylinder
FS 120, 120 R

Carter, Cylindre FS 120,
120 R

Bild-Nr.	Teile-Nr.	St-Zahl	Benennung	Part Name	Désignation
1	4134 020 2600	1	Kurbelgehäusehälfte (1,2) □ 2, 3	Crankcase (1,2) □ 2, 3	Demi-carter de vilebrequin (1,2) □ 2, 3
2	0000 988 8600	4	Hülse 5x12 (1,2)	Sleeve 5x12 (1,2)	Douille 5x12 (1,2)
3	9503 003 0242	2	Kugellager DIN625-6201 (1,2)	Grooved ball bearing 6201 (1,2)	Roulement rainuré à billes 6201 (1,2)
4	4134 020 2900	1	Kurbelgehäusehälfte (1,2) □ 3	Crankcase (1,2) □ 3	Demi-carter de vilebrequin (1,2) □ 3
5	9640 003 1195	2	WDR DIN3760-BS12x22x5 (1,2)	Oil seal 12x22x5 (1,2)	Bague d'étanchéité 12x22x5 (1,2)
6	4134 030 0400	1	Kurbelwelle (1,2)	Crankshaft (1,2)	Vilebrequin (1,2)
7	9075 478 4159	5	Schraube IS-D5x24 (1,2)	Pan head self-tapping screw IS-D5x24 (1,2)	Vis cylindrique IS-D5x24 (1,2)
8	9075 478 4175	4	Schraube IS-D5x28 (1,2)	Pan head self-tapping screw IS-D5x28 (1,2)	Vis cylindrique IS-D5x28 (1,2)
9	4134 029 2300	1	Zylinderdichtung (1,2)	Cylinder gasket (1,2)	Joint de cylindre (1,2)
10	9512 003 2250	1	Nadelkranz 10x13x12,5 (1,2)	Needle cage 10x13x12.5 (1,2)	Cage à aiguilles 10x13x12,5 (1,2)
11	4134 020 1213	1	Zylinder mit Kolben Ø 35 mm (1,2) □ 8, 12 - 15	Cylinder with piston Ø 35mm (1,2) □ 8, 12 - 15	Cylindre avec piston Ø 35 mm (1,2) □ 8, 12 - 15
12	4134 030 2011	1	Kolben Ø 35 mm (1,2) □ 13 - 15	Piston Ø 35mm (1,2) □ 13 - 15	Piston Ø 35 mm (1,2) □ 13 - 15
13	4119 034 3005	2	Verdichtungsring Ø 35x1,5 mm (1,2)	Piston ring Ø 35x1.5mm (1,2)	Segment de piston Ø 35x1,5 mm (1,2)
14	4119 034 1500	1	Kolbenbolzen (1,2)	Piston pin (1,2)	Axe de piston (1,2)
15	9463 650 1000	2	Sprengring DIN73130-C10 (1,2)	Snap ring 10 (1,2)	Jonc d'arrêt 10 (1,2)
16	0000 400 7000	1	Zündkerze NGK BPMR7A (1,2)	Spark plug NGK BPMR7A (1,2)	Bougie NGK BPMR7A (1,2)
16	1110 400 7005	1	Zündkerze Bosch WSR 6 F (1,2)	Spark plug Bosch WSR 6 F (1,2)	Bougie Bosch WSR 6 F (1,2)
17	4134 149 0600	1	Auspuffdichtung (1,2)	Exhaust gasket (1,2)	Joint d'échappement (1,2)
18	0783 830 2000	1	Dichtungsmasse Dirko HT rot (B) (1,2)	Tube of sealant Dirko HT red (B) (1,2)	Tube de pâte d'étanchéité Dirko HT rouge (B) (1,2)
	4134 007 1050	1	Dichtungssatz (1,2) □ 5, 9, 17	Set of gaskets (1,2) □ 5, 9, 17	Jeu de joints (1,2) □ 5, 9, 17

(1) FS 120, (2) FS 120 R, (3) FS 200, (4) FS 200 R, (5) FS 250, (6) FS 250 R

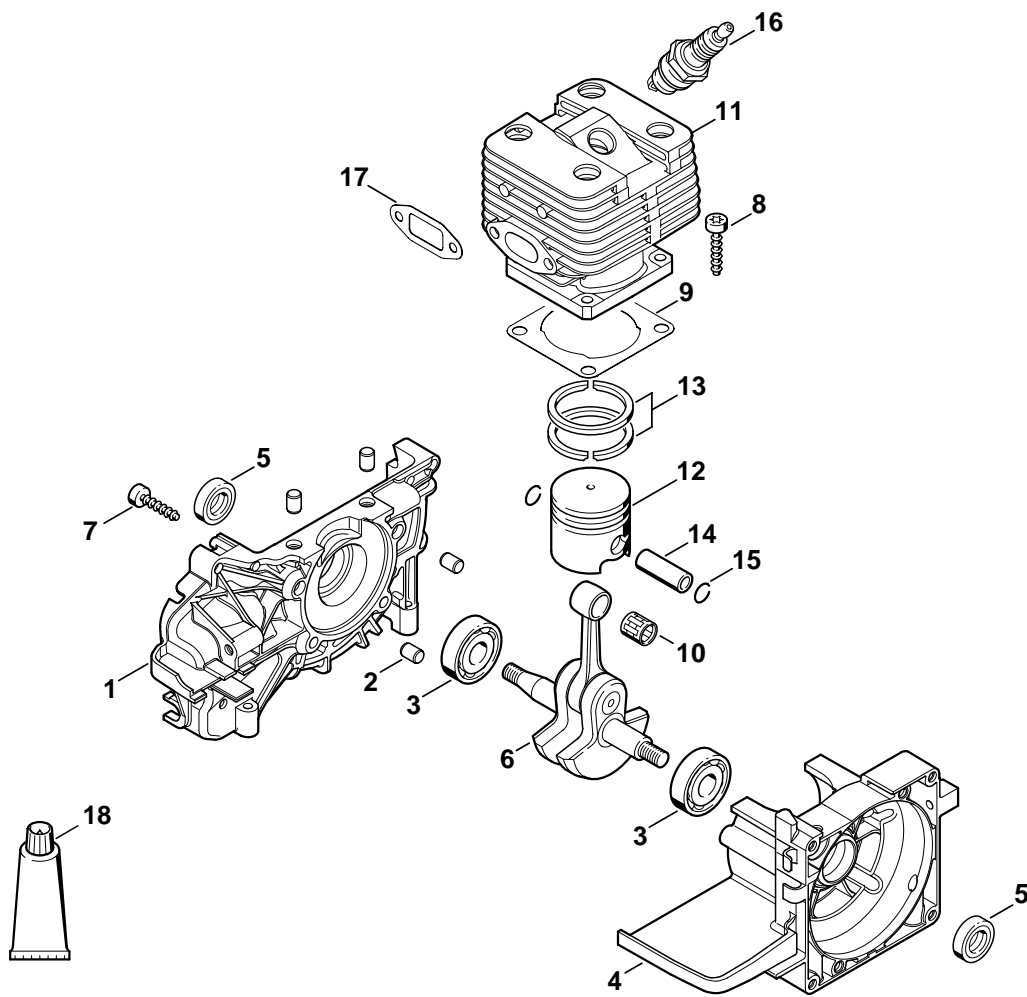

250ET020 GM

Illustration B

Kurbelgehäuse, Zylinder
FS 200, 200 R

Crankcase, Cylinder
FS 200, 200 R

Carter, Cylindre FS 200,
200 R

Bild-Nr.	Teile-Nr.	St-Zahl	Benennung	Part Name	Désignation
1	4134 020 2600	1	Kurbelgehäusehälfte (3,4) □ 2, 3	Crankcase (3,4) □ 2, 3	Demi-carter de vilebrequin (3,4) □ 2, 3
2	0000 988 8600	4	Hülse 5x12 (3,4)	Sleeve 5x12 (3,4)	Douille 5x12 (3,4)
3	9503 003 0242	2	Kugellager DIN625-6201 (3,4)	Grooved ball bearing 6201 (3,4)	Roulement rainuré à billes 6201 (3,4)
4	4134 020 2900	1	Kurbelgehäusehälfte (3,4) □ 3	Crankcase (3,4) □ 3	Demi-carter de vilebrequin (3,4) □ 3
5	9640 003 1195	2	WDR DIN3760-BS12x22x5 (3,4)	Oil seal 12x22x5 (3,4)	Bague d'étanchéité 12x22x5 (3,4)
6	4134 030 0400	1	Kurbelwelle (3,4)	Crankshaft (3,4)	Vilebrequin (3,4)
7	9075 478 4159	5	Schraube IS-D5x24 (3,4)	Pan head self-tapping screw IS-D5x24 (3,4)	Vis cylindrique IS-D5x24 (3,4)
8	9075 478 4175	4	Schraube IS-D5x28 (3,4)	Pan head self-tapping screw IS-D5x28 (3,4)	Vis cylindrique IS-D5x28 (3,4)
9	4134 029 2300	1	Zylinderdichtung (3,4)	Cylinder gasket (3,4)	Joint de cylindre (3,4)
10	9512 003 2250	1	Nadelkranz 10x13x12,5 (3,4)	Needle cage 10x13x12.5 (3,4)	Cage à aiguilles 10x13x12,5 (3,4)
11	4134 020 1212	1	Zylinder mit Kolben Ø 38 mm (3,4) □ 8, 12 - 15	Cylinder with piston Ø 38mm (3,4) □ 8, 12 - 15	Cylindre avec piston Ø 38 mm (3,4) □ 8, 12 - 15
12	4134 030 2010	1	Kolben Ø 38 mm (3,4) □ 13 - 15	Piston Ø 38mm (3,4) □ 13 - 15	Piston Ø 38 mm (3,4) □ 13 - 15
13	4119 034 3000	2	Verdichtungsring Ø 38x1,5 mm (3,4)	Piston ring Ø 38x1.5mm (3,4)	Segment de piston Ø 38x1,5 mm (3,4)
14	4119 034 1500	1	Kolbenbolzen (3,4)	Piston pin (3,4)	Axe de piston (3,4)
15	9463 650 1000	2	Sprengring DIN73130-C10 (3,4)	Snap ring 10 (3,4)	Jonc d'arrêt 10 (3,4)
16	0000 400 7000	1	Zündkerze NGK BPMR7A (3,4)	Spark plug NGK BPMR7A (3,4)	Bougie NGK BPMR7A (3,4)
16	1110 400 7005	1	Zündkerze Bosch WSR 6 F (3,4)	Spark plug Bosch WSR 6 F (3,4)	Bougie Bosch WSR 6 F (3,4)
17	4134 149 0600	1	Auspuffdichtung (3,4)	Exhaust gasket (3,4)	Joint d'échappement (3,4)
18	0783 830 2000	1	Dichtungsmasse Dirko HT rot (B) (3,4)	Tube of sealant Dirko HT red (B) (3,4)	Tube de pâte d'étanchéité Dirko HT rouge (B) (3,4)
	4134 007 1050	1	Dichtungssatz (3,4) □ 5, 9, 17	Set of gaskets (3,4) □ 5, 9, 17	Jeu de joints (3,4) □ 5, 9, 17

(1) FS 120, (2) FS 120 R, (3) FS 200, (4) FS 200 R, (5) FS 250, (6) FS 250 R

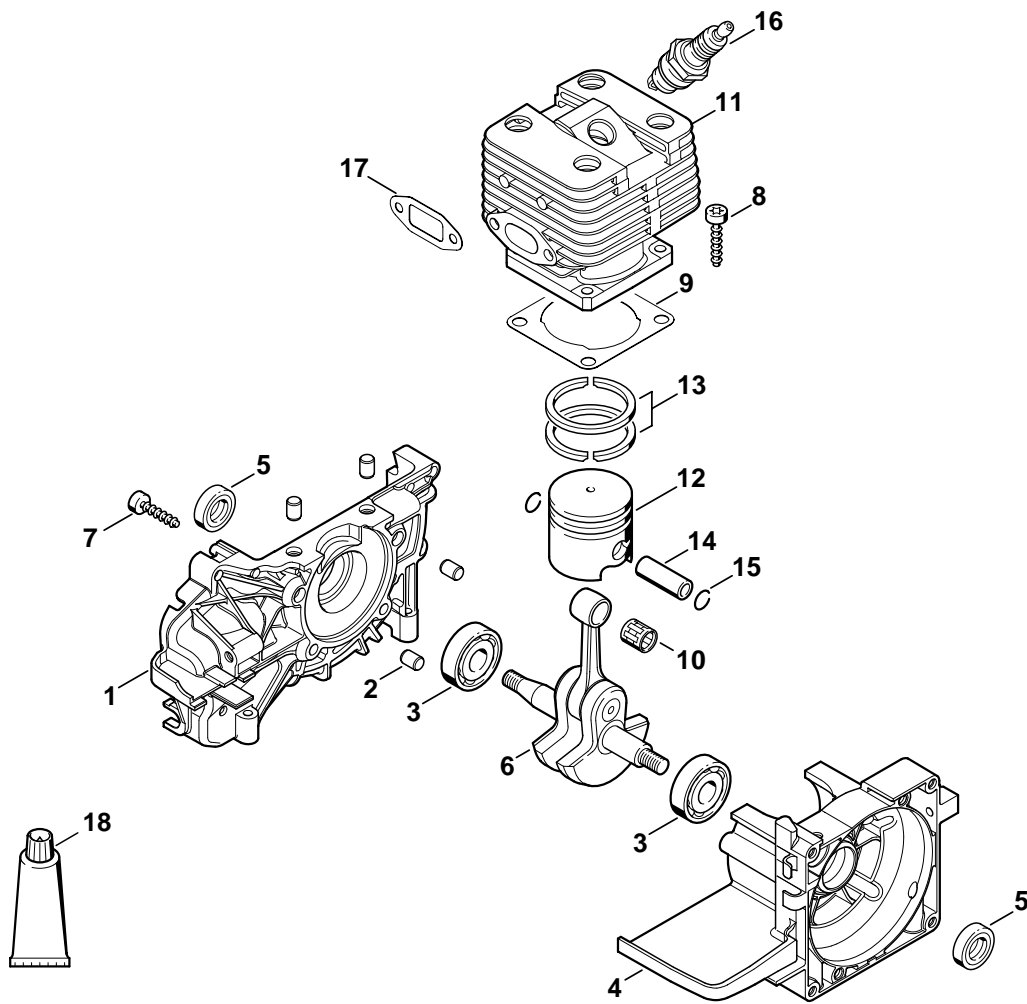

250ET021 GM

Illustration C

Kurbelgehäuse, Zylinder
FS 250, 250 R

Crankcase, Cylinder
FS 250, 250 R

Carter, Cylindre FS 250,
250 R

Bild-Nr.	Teile-Nr.	St-Zahl	Benennung	Part Name	Désignation
1	4134 020 2600	1	Kurbelgehäusehälfte (5,6) □ 2, 3	Crankcase (5,6) □ 2, 3	Demi-carter de vilebrequin (5,6) □ 2, 3
2	0000 988 8600	4	Hülse 5x12 (5,6)	Sleeve 5x12 (5,6)	Douille 5x12 (5,6)
3	9503 003 0242	2	Kugellager DIN625-6201 (5,6)	Grooved ball bearing 6201 (5,6)	Roulement rainuré à billes 6201 (5,6)
4	4134 020 2900	1	Kurbelgehäusehälfte (5,6) □ 3	Crankcase (5,6) □ 3	Demi-carter de vilebrequin (5,6) □ 3
5	9640 003 1195	2	WDR DIN3760-BS12x22x5 (5,6)	Oil seal 12x22x5 (5,6)	Bague d'étanchéité 12x22x5 (5,6)
6	4134 030 0400	1	Kurbelwelle (5,6)	Crankshaft (5,6)	Vilebrequin (5,6)
7	9075 478 4159	5	Schraube IS-D5x24 (5,6)	Pan head self-tapping screw IS-D5x24 (5,6)	Vis cylindrique IS-D5x24 (5,6)
8	9075 478 4175	4	Schraube IS-D5x28 (5,6)	Pan head self-tapping screw IS-D5x28 (5,6)	Vis cylindrique IS-D5x28 (5,6)
9	4134 029 2300	1	Zylinderdichtung (5,6)	Cylinder gasket (5,6)	Joint de cylindre (5,6)
10	9512 003 2250	1	Nadelkranz 10x13x12,5 (5,6)	Needle cage 10x13x12.5 (5,6)	Cage à aiguilles 10x13x12,5 (5,6)
11	4134 020 1214	1	Zylinder mit Kolben Ø 40 mm (5,6) □ 8, 12 - 15	Cylinder with piston Ø 40mm (5,6) □ 8, 12 - 15	Cylindre avec piston Ø 40 mm (5,6) □ 8, 12 - 15
12	4134 030 2003	1	Kolben Ø 40 mm (5,6) □ 13 - 15	Piston Ø 40mm (5,6) □ 13 - 15	Piston Ø 40 mm (5,6) □ 13 - 15
13	1114 034 3001	2	Verdichtungsring Ø 40x1,5 mm (5,6)	Piston ring Ø 40x1.5mm (5,6)	Segment de piston Ø 40x1,5 mm (5,6)
14	4119 034 1500	1	Kolbenbolzen (5,6)	Piston pin (5,6)	Axe de piston (5,6)
15	9463 650 1000	2	Sprengring DIN73130-C10 (5,6)	Snap ring 10 (5,6)	Jonc d'arrêt 10 (5,6)
16	0000 400 7000	1	Zündkerze NGK BPMR7A (5,6)	Spark plug NGK BPMR7A (5,6)	Bougie NGK BPMR7A (5,6)
16	1110 400 7005	1	Zündkerze Bosch WSR 6 F (5,6)	Spark plug Bosch WSR 6 F (5,6)	Bougie Bosch WSR 6 F (5,6)
17	4134 149 0600	1	Auspuffdichtung (5,6)	Exhaust gasket (5,6)	Joint d'échappement (5,6)
18	0783 830 2000	1	Dichtungsmasse Dirko HT rot (B) (5,6)	Tube of sealant Dirko HT red (B) (5,6)	Tube de pâte d'étanchéité Dirko HT rouge (B) (5,6)
	4134 007 1050	1	Dichtungssatz (5,6) □ 5, 9, 17	Set of gaskets (5,6) □ 5, 9, 17	Jeu de joints (5,6) □ 5, 9, 17

(1) FS 120, (2) FS 120 R, (3) FS 200, (4) FS 200 R, (5) FS 250, (6) FS 250 R

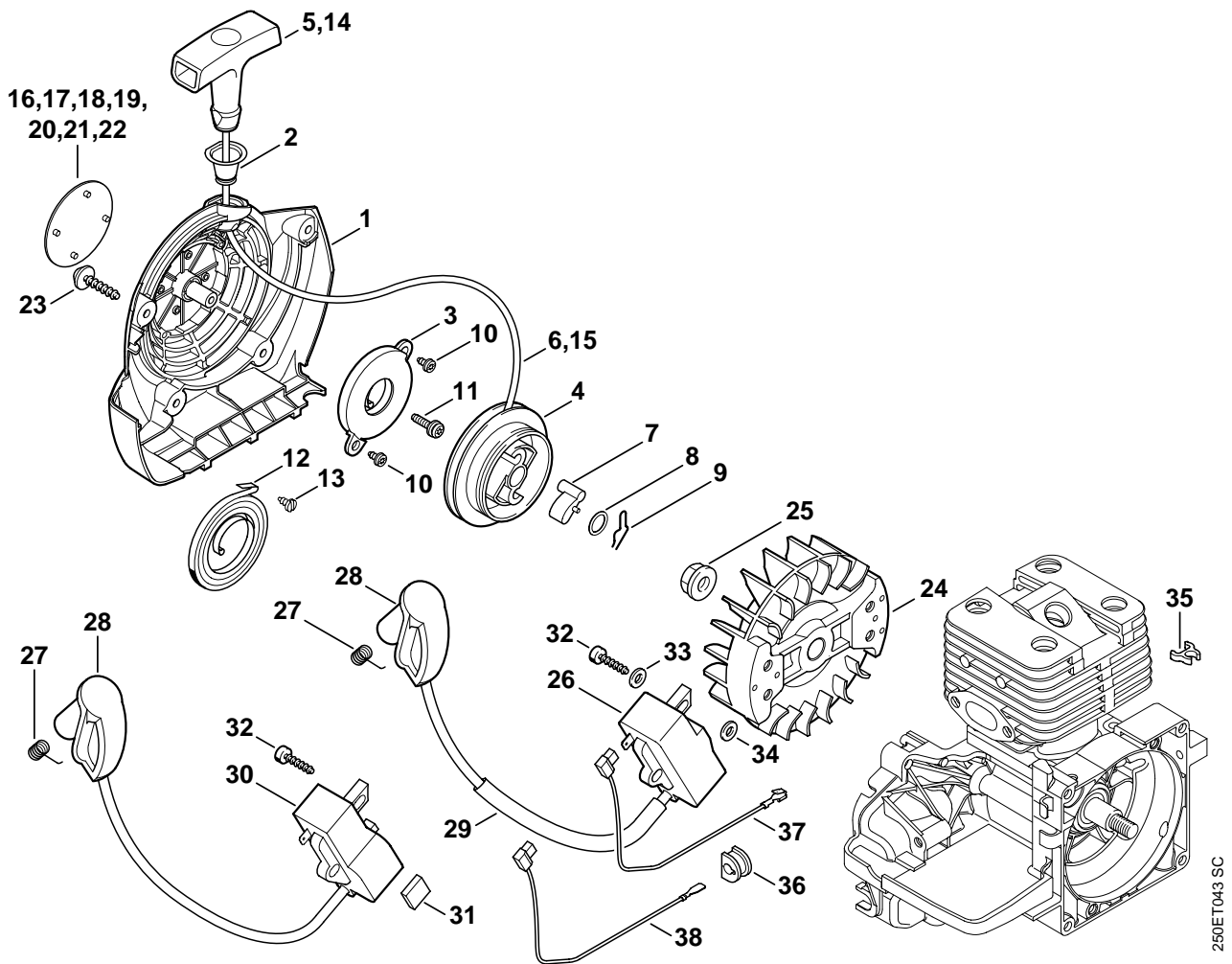

250ET043 SC

Illustration D

Anwerfvorrichtung,
Zündanlage

Rewind starter, Ignition
system

Dispositif de lancement,
Dispositif d'allumage

Bild-Nr.	Teile-Nr.	St-Zahl	Benennung	Part Name	Désignation
	4134 080 2101	1	Lüftergehäuse mit Anwerfvorrichtung □ 1 - 11	Fan housing with rewind starter □ 1 - 11	Carter de ventilateur avec lanceur □ 1 - 11
1	4134 080 1801	1	Lüftergehäuse □ 2	Fan housing □ 2	Carter de ventilateur □ 2
2	1110 084 9102	1	Buchse	Bushing	Douille
3	4134 190 0601	1	Rückholfeder	Rewind spring	Ressort de rappel
4	4128 195 0400	1	Seilrolle	Rope rotor	Poulie à câble
5	0000 190 3405	1	Griff ElastoStart Ø 3 mm □ 6	Starter grip ElastoStart Ø 3mm □ 6	Poignée ElastoStart Ø 3 mm □ 6
6	0000 195 8203	1	Anwerfseil Ø 3x850 mm	Starter rope Ø 3x850mm	Câble de lancement Ø 3x850 mm
7	0000 195 7200	1	Klinke	Pawl	Cliquet
8	0000 958 0923	1	Scheibe	Washer	Rondelle
9	1118 195 3500	1	Feder	Spring	Ressort
10	9104 003 0410	2	Schraube P3x6	Self-tapping screw P3x6	Vis Parker P3x6
11	4223 084 5600	1	Nutschraube (22.2001)	Screw (22.2001)	Vis à encoche (22.2001)
12 *	4134 190 0600	1	Rückholfeder	Rewind spring	Ressort de rappel
13 *	9099 021 2330	1	Schraube DIN7971-3,5x6,5	Self-tapping screw 3.5x6.5	Vis Parker 3,5x6,5
14 *	0000 190 3400	1	Griff ElastoStart Ø 3 mm □ 15	Starter grip ElastoStart Ø 3mm □ 15	Poignée ElastoStart Ø 3 mm □ 15
15 *	0000 195 8200	1	Anwerfseil Ø 3x800 mm	Starter rope Ø 3x800mm	Câble de lancement Ø 3x800 mm
16	4134 967 1511	1	Typenschild FS 120 (1)	Model plate FS 120 (1)	Plaque matricule FS 120 (1)
17	4134 967 1529	1	Typenschild FS 120 R (2)	Model plate FS 120 R (2)	Plaque matricule FS 120 R (2)
18	4134 967 1510	1	Typenschild FS 200 (3)	Model plate FS 200 (3)	Plaque matricule FS 200 (3)
19	4134 967 1530	1	Typenschild FS 200 R (4)	Model plate FS 200 R (4)	Plaque matricule FS 200 R (4)
20	4134 967 1513	1	Typenschild FS 250 (5)	Model plate FS 250 (5)	Plaque matricule FS 250 (5)
21	4134 967 1531	1	Typenschild FS 250 R (6) (22.2001)	Model plate FS 250 R (6) (22.2001)	Plaque matricule FS 250 R (6) (22.2001)
22 *	0000 967 1500	1	Firmenzeichen STIHL	Nameplate STIHL	Emblème STIHL

(1) FS 120, (2) FS 120 R, (3) FS 200, (4) FS 200 R, (5) FS 250, (6) FS 250 R

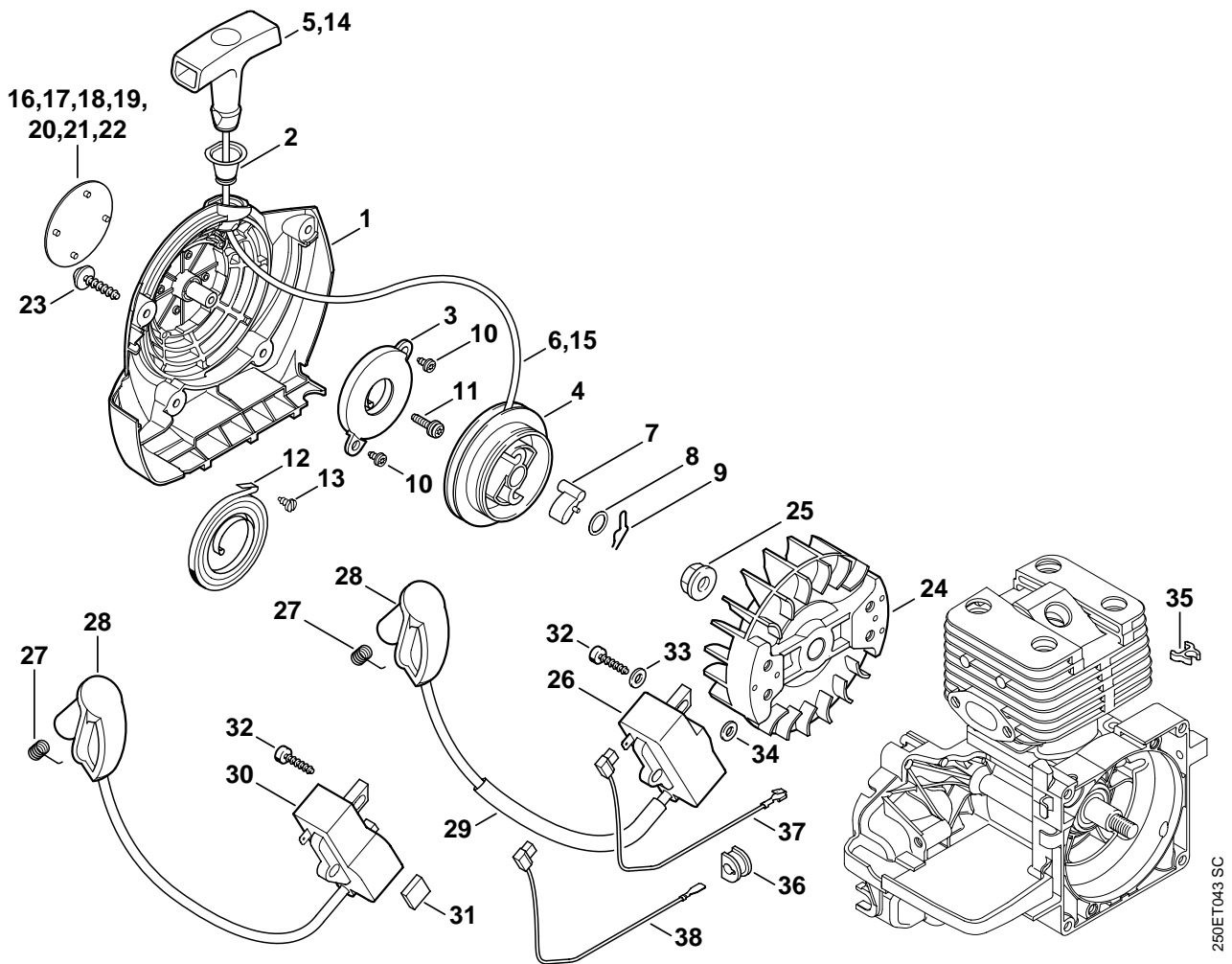

250ET043 SC

Illustration D

Anwerfvorrichtung,
Zündanlage

Rewind starter, Ignition
system

Dispositif de lancement,
Dispositif d'allumage

Bild-Nr.	Teile-Nr.	St-Zahl	Benennung	Part Name	Désignation
23	0000 951 1100	4	Schraube IS-D5x20	Screw IS-D5x20	Vis cylindrique IS-D5x20
24	4134 400 1200	1	Schwungrad	Flywheel	Rotor
25	9220 260 1100	1	Mutter DIN6923-M8-8	Hexagon nut M8	Ecrou à six pans M8
26	4134 400 1301	1	Zündmodul □ 27 - 29	Ignition module □ 27 - 29	Module d'allumage □ 27 - 29
27	0000 998 0604	1	Schenkelfeder	Torsion spring	Ressort coudé
28	4128 405 1000	1	Zündleistungsstecker	Spark plug boot	Contact de câble d'allumage
29	4137 442 0400	1	Isolierschlauch	Insulating hose	Gainé isolante
			(22.2001)	(22.2001)	(22.2001)
30 *	4134 400 1306	1	Zündmodul □ 27, 28	Ignition module □ 27, 28	Module d'allumage □ 27, 28
31 *	4134 028 1300	1	Unterlage 10x15x4	Shim 10x15x4	Cale 10x15x4
32	9075 478 3022	2	Schraube IS-D4x20	Pan head self-tapping screw IS-D4x20	Vis cylindrique IS-D4x20
33	9291 021 0121	2	Scheibe DIN125-A5,3	Washer 5.3	Rondelle 5,3
			(22.2001)	(22.2001)	(22.2001)
34 *	9291 021 0121	2	Scheibe DIN125-A5,3	Washer 5.3	Rondelle 5,3
			(09.2003)	(09.2003)	(09.2003)
35 *	4134 448 1200	1	Kabelhalter	Lead retainer	Attache de câble
36	4134 432 9300	1	Tülle	Grommet	Douille
37	4134 440 1101	1	Kurzschließeleitung	Short circuit wire	Câble de court-circuit
			(09.2003)	(09.2003)	(09.2003)
38 *	4134 440 1100	1	Kurzschließeleitung	Short circuit wire	Câble de court-circuit

(1) FS 120, (2) FS 120 R, (3) FS 200, (4) FS 200 R, (5) FS 250, (6) FS 250 R

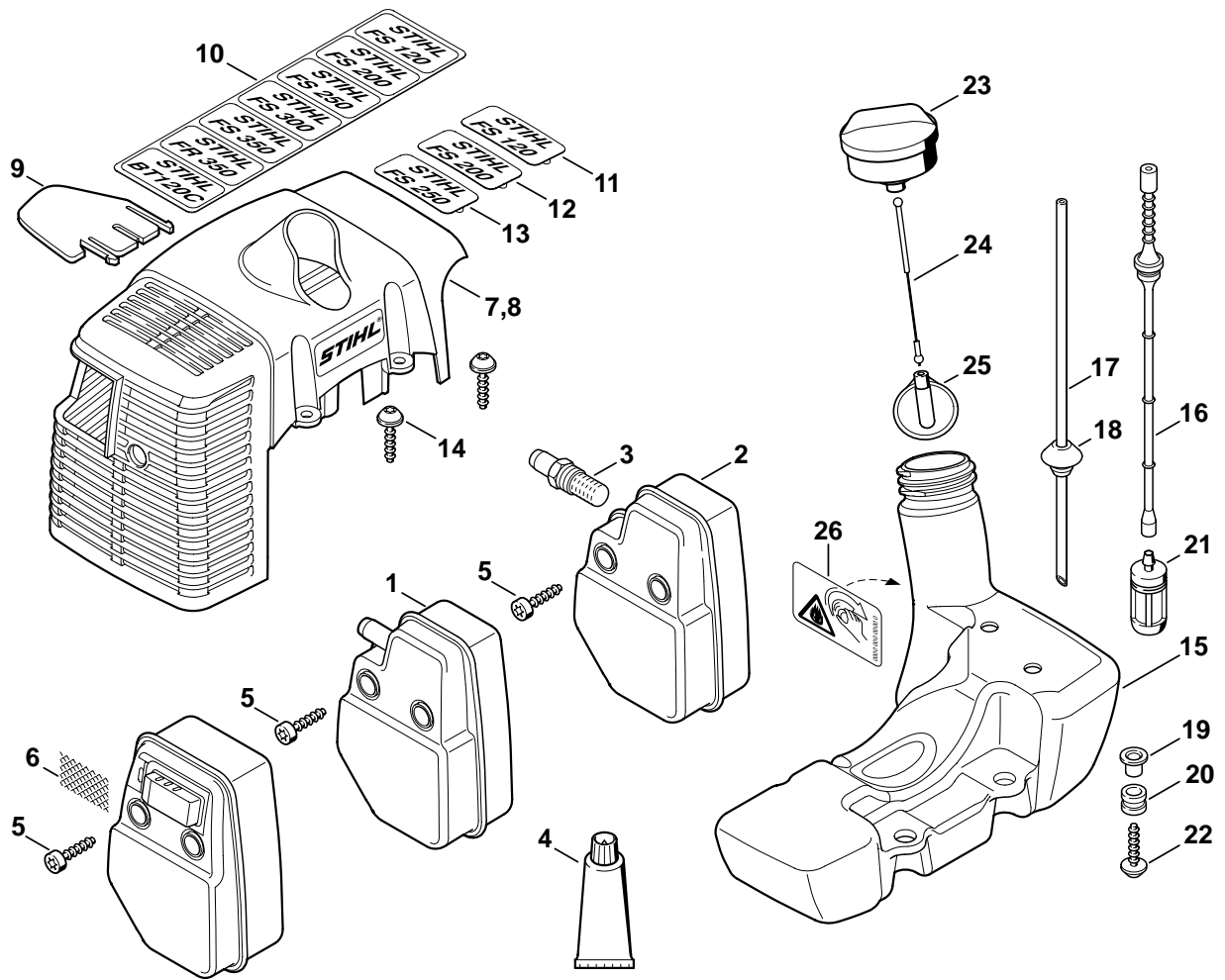

250ET047 GM

Illustration E

Haube, Kraftstofftank

Shroud, Fuel tank

Capot, Réservoir d'essence

Bild-Nr.	Teile-Nr.	St-Zahl	Benennung	Part Name	Désignation
1	4134 140 0602	1	Schalldämpfer	Muffler	Silencieux
			➔ 1 43 491 570 (22.2001)	➔ 1 43 491 570 (22.2001)	➔ 1 43 491 570 (22.2001)
	* 4134 140 0652	1	Schalldämpfer □ 1, 5, 8, 10	Muffler □ 1, 5, 8, 10	Silencieux □ 1, 5, 8, 10
2	4134 140 0606	1	Schalldämpfer USA, AUS, CDN □ 3	Muffler USA, AUS, CDN □ 3	Silencieux USA, AUS, CDN □ 3
3	4140 140 6900	1	Stutzen mit Gitter USA, AUS, CDN	Stub with screen USA, AUS, CDN	Embout avec grille USA, AUS, CDN
4	0783 830 2000	1	Dichtungsmasse Dirko HT rot (B)	Tube of sealant Dirko HT red (B)	Tube de pâte d'étanchéité Dirko HT rouge (B)
5	9075 478 4159	2	Schraube IS-D5x24	Pan head self-tapping screw IS-D5x24	Vis cylindrique IS-D5x24
			➔ 1 43 491 570 (21.2000)	➔ 1 43 491 570 (21.2000)	➔ 1 43 491 570 (21.2000)
6 *	4134 141 9000	1	Gitter USA, AUS, CDN	Screen USA, AUS, CDN	Grille USA, AUS, CDN
7	4134 084 0911	1	Haube	Shroud	Capot
			(09.2003)	(09.2003)	(09.2003)
8 *	4134 080 1600	1	Haube □ 10	Shroud □ 10	Capot □ 10
9	4134 084 6800	1	Distanzstück USA, AUS	Spacer USA, AUS	Pièce d'écartement USA, AUS
10 *	4134 967 1514	1	Typenschild (22.2001)	Model plate (22.2001)	Plaque matricule (22.2001)
11 *	4134 967 1503	1	Typenschild FS 120 (1,2)	Model plate FS 120 (1,2)	Plaque matricule FS 120 (1,2)
12 *	4134 967 1502	1	Typenschild FS 200 (3,4)	Model plate FS 200 (3,4)	Plaque matricule FS 200 (3,4)
13 *	4134 967 1506	1	Typenschild FS 250 (5,6)	Model plate FS 250 (5,6)	Plaque matricule FS 250 (5,6)
14	0000 951 1100	2	Schraube IS-D5x20	Screw IS-D5x20	Vis cylindrique IS-D5x20
15	4134 350 0400	1	Kraftstofftank □ 16 - 21	Fuel tank □ 16 - 21	Réservoir d'essence □ 16 - 21
16	4128 358 0800	1	Schlauch	Hose	Tuyau
17	4134 358 7600	1	Schlauch	Hose	Tuyau
18	0000 989 0516	1	Tülle	Grommet	Douille
19	0000 351 3200	4	Hülse	Sleeve	Douille
20	1125 084 8900	4	Tülle	Grommet	Douille
21	0000 350 3506	1	Saugkopf	Pickup body	Crépine d'aspiration
22	0000 951 1102	4	Schraube D5x26	Screw D5x26	Vis cylindrique D5x26
23	4128 350 0505	1	Tankverschluss □ 24, 25	Filler cap □ 24, 25	Bouchon du réservoir □ 24, 25
24	0000 350 0900	1	Seil	Rope	Corde
25	0000 353 0800	1	Verliersicherung	Filler cap retainer	Pièce de sûreté

(1) FS 120, (2) FS 120 R, (3) FS 200, (4) FS 200 R, (5) FS 250, (6) FS 250 R

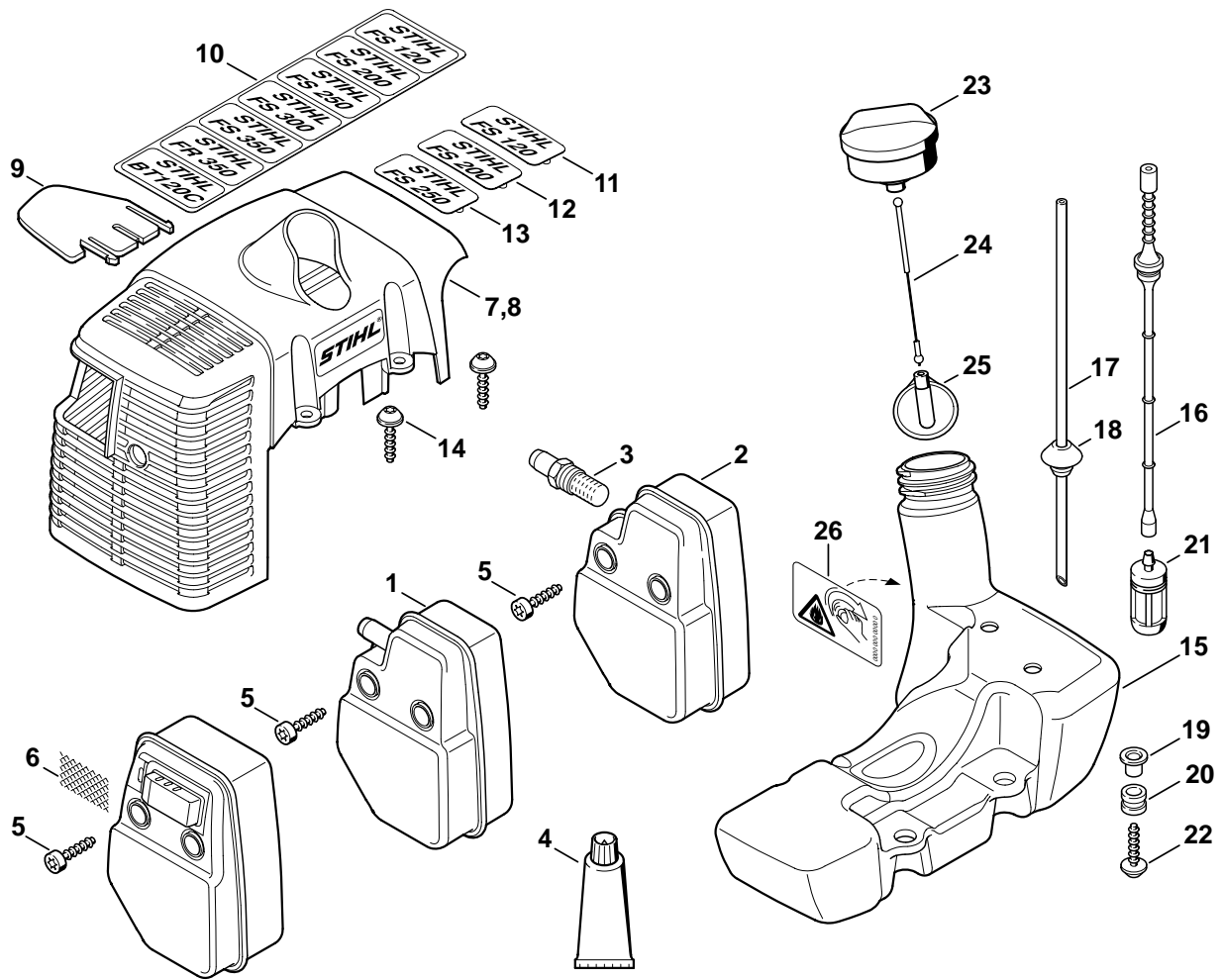

250ET047 GM

Illustration E

Haube, Kraftstofftank

Shroud, Fuel tank

Capot, Réservoir d'essence

Bild-Nr.	Teile-Nr.	St-Zahl	Benennung	Part Name	Désignation
26	0000 967 3693	1	Warnhinweis Piktogramm Tankdeckel USA, CDN	Warning pictogram Filler cap USA, CDN	Pictogramme d'avertissement Bouchon de réservoir USA, CDN

(1) FS 120, (2) FS 120 R, (3) FS 200, (4) FS 200 R, (5) FS 250, (6) FS 250 R

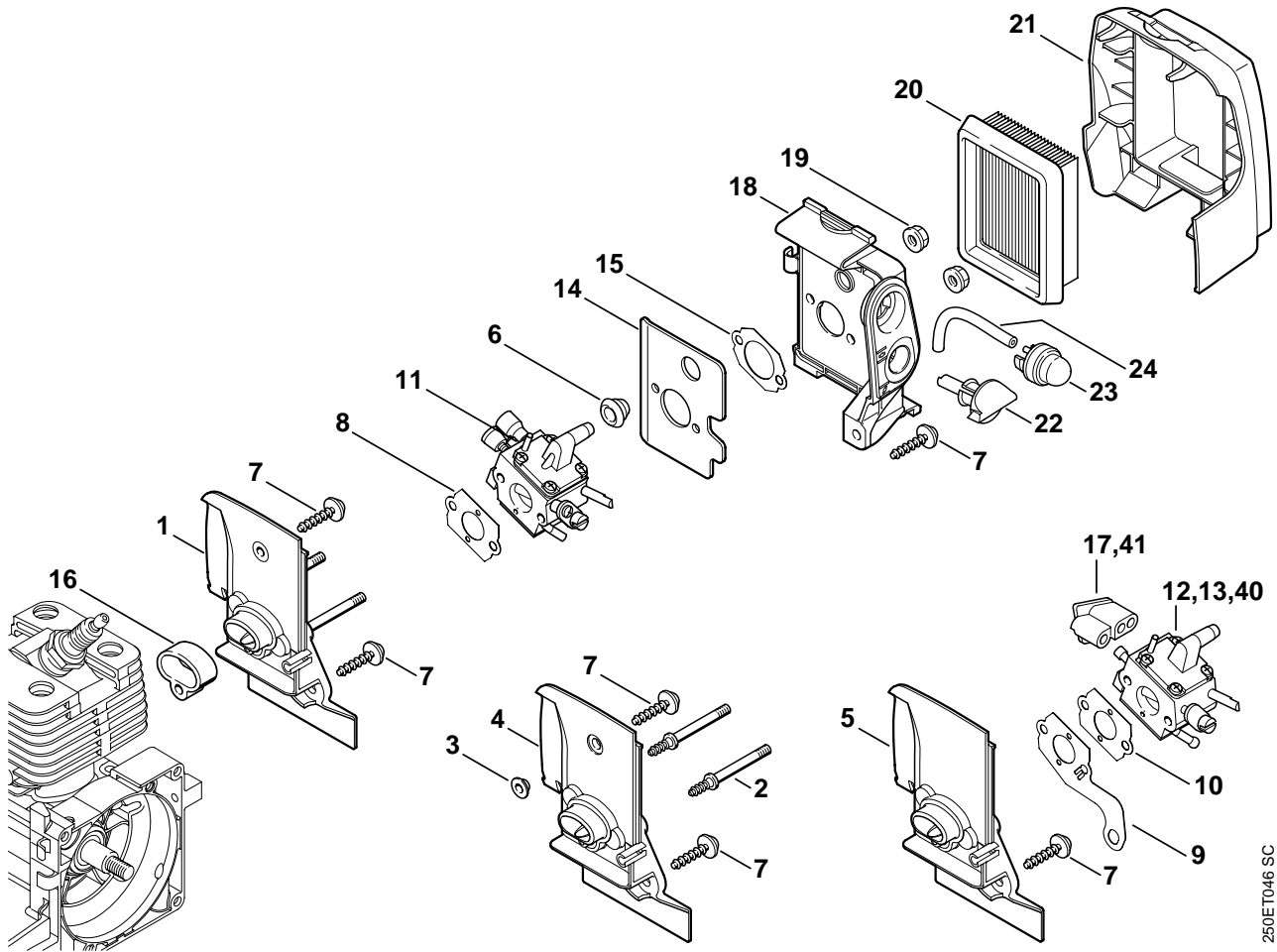

250ET046 SC

Illustration F

Vergasergehäuse, Luftfilter

Carburetor housing, Air filter

Carter de carburateur, Filtre à air

Bild-Nr.	Teile-Nr.	St-Zahl	Benennung	Part Name	Désignation
1	4134 120 0102	1	Vergasergehäuse	Carburetor housing	Carter de carburateur
2 *	4134 122 6601	2	Bundschaube	Collar screw	Vis à embase
3 *	0000 963 1403	1	Buchse	Bushing	Douille
			(09.2003)	(09.2003)	(09.2003)
4 *	4134 120 0101	1	Vergasergehäuse □ 2, 3	Carburetor housing □ 2, 3	Carter de carburateur □ 2, 3
			(22.2001)	(22.2001)	(22.2001)
5 *	4134 120 0100	1	Vergasergehäuse □ 2	Carburetor housing □ 2	Carter de carburateur □ 2
6	4134 123 7500	1	Tülle	Grommet	Douille
7	0000 951 1100	6	Schraube IS-D5x20	Screw IS-D5x20	Vis cylindrique IS-D5x20
8	4128 129 0900	1	Dichtung	Gasket	Joint
			(09.2003)	(09.2003)	(09.2003)
9 *	4134 431 7000	1	Kontaktblech	Contact plate	Tôle de contact
10 *	4128 129 0900	1	Dichtung	Gasket	Joint
11	4134 120 0603	1	Vergaser C1Q-S82 (1,2)	Carburetor C1Q-S82 (1,2)	Carburateur C1Q-S82 (1,2)
12	4134 120 0604	1	Vergaser C1Q-S83 (3,4,5,6)	Carburetor C1Q-S83 (3,4,5,6)	Carburateur C1Q-S83 (3,4,5,6)
			(09.2003)	(09.2003)	(09.2003)
13 *	4134 120 0651	1	Vergaser C1Q-S51C	Carburetor C1Q-S51C	Carburateur C1Q-S51C
14	4134 122 1800	1	Abstrahlblech	Heat shield	Tôle calorifuge
15	4134 129 0900	1	Dichtung	Gasket	Joint
16	4134 129 3000	1	Dichtring	Sealing ring	Anneau de joint
			(09.2003)	(09.2003)	(09.2003)
17 *	4134 123 7502	1	Tülle	Grommet	Douille
18	4134 140 2800	1	Filtergehäuse □ 15	Filter housing □ 15	Boîtier de filtre □ 15
19	9220 260 0700	2	Mutter DIN6923-M5-8	Hexagon nut M5	Ecrou à six pans M5
20	4134 141 0300	1	Luftfilter	Air filter	Filtre à air
21	4134 141 0500	1	Filterdeckel	Filter cover	Couvercle de filtre
22	4128 182 9500	1	Drehknopf	Choke knob	Bouton de réglage
23	4130 350 6200	1	Kraftstoffpumpe	Fuel pump	Pompe à carburant
24		1	Schlauch 2,2x5,4x68 (D)	Hose 2.2x5.4x68 (D)	Tuyau 2,2x5,4x68 (D)
	0000 930 2802	1	Schlauch 2,2x5,4 mm x 1 m (A,B)	Hose 2.2x5.4 mm x 1 m (A,B)	Tuyau 2,2x5,4 mm x 1 m (A,B)
	4134 007 1050	1	Dichtungssatz □ 8	Set of gaskets □ 8	Jeu de joints □ 8
			(19.98)	(19.98)	(19.98)
40 *		1	Vergaser C1Q-S35B (C)	Carburetor C1Q-S35B (C)	Carburateur C1Q-S35B (C)
41 *	4134 123 7501	1	Tülle	Grommet	Douille

(1) FS 120, (2) FS 120 R, (3) FS 200, (4) FS 200 R, (5) FS 250, (6) FS 250 R

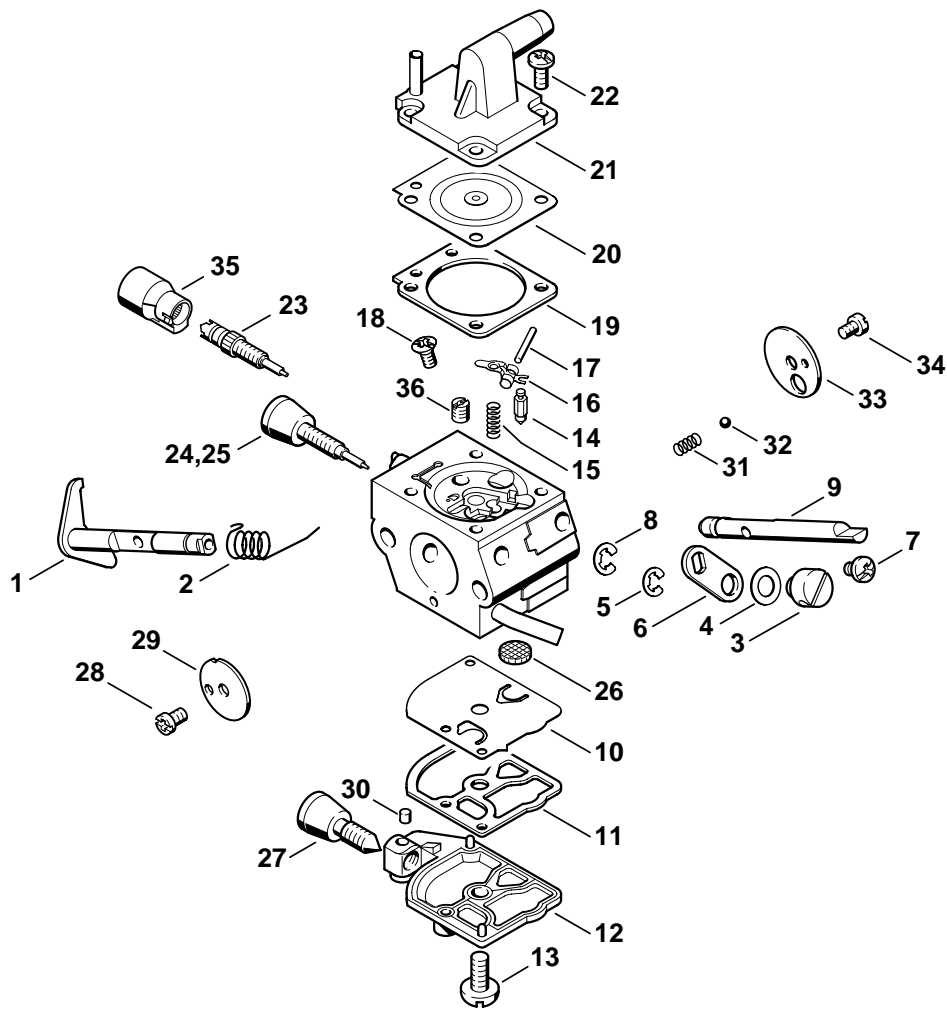

250ET034 SC

Illustration G

Vergaser C1Q-S82,
C1Q-S83

Carburetor C1Q-S82,
C1Q-S83

Carburateur C1Q-S82,
C1Q-S83

Bild-Nr.	Teile-Nr.	St-Zahl	Benennung	Part Name	Désignation
	4134 120 0603	1	Vergaser C1Q-S82 (1,2) □ 1 - 24, 26 - 36	Carburetor C1Q-S82 (1,2) □ 1 - 24, 26 - 36	Carburateur C1Q-S82 (1,2) □ 1 - 24, 26 - 36
	4134 120 0604	1	Vergaser C1Q-S83 (3,4,5,6) □ 1 - 23, 25 - 36	Carburetor C1Q-S83 (3,4,5,6) □ 1 - 23, 25 - 36	Carburateur C1Q-S83 (3,4,5,6) □ 1 - 23, 25 - 36
1	4134 120 7101	1	Drosselwelle mit Hebel	Throttle shaft with lever	Axe de papillon avec levier
2	1123 122 3000	1	Feder	Spring	Ressort
3	4128 121 8901	1	Bolzen	Pin	Boulon
4	4137 121 8600	1	Scheibe	Washer	Rondelle
5	1120 122 9000	1	Sicherungsring	E-clip	Circlip
6	4134 123 7300	1	Hebel	Lever	Levier
7	9079 319 0280	1	Schraube M3x3,5	Flat head screw M3x3.5	Vis à tête plate M3x3,5
8	1120 122 9000	1	Sicherungsring	E-clip	Circlip
9	4134 121 3000	1	Startwelle	Choke shaft	Axe de volet de démarrage
10	1129 121 4800	1	Pumpenmembrane	Pump diaphragm	Membrane de pompe
11	1123 129 0905	1	Dichtung	Gasket	Joint
12	1123 121 0800	1	Abschlussdeckel	End cover	Couvercle
13	1120 122 7800	1	Linsensenschraube	Oval head screw	Vis à tête bombée fraisée
14	4116 121 5100	1	Einlassnadel	Inlet needle	Pointeau d'admission
15	1123 122 3001	1	Feder	Spring	Ressort
16	1125 121 5000	1	Einlassregelhebel	Inlet control lever	Levier de réglage d'admission
17	1120 121 9200	1	Achse	Spindle	Axe
18	1120 122 6600	1	Bundschrabe	Collar screw	Vis à embase
19	1129 129 0900	1	Dichtung	Gasket	Joint
20	4129 121 4700	1	Regelmembrane	Metering diaphragm	Membrane de réglage
21	4134 121 0801	1	Abschlussdeckel	End cover	Couvercle
22	1120 122 6601	4	Bundschrabe	Collar screw	Vis à embase
23	4134 122 6701	1	Hauptstellschraube	High speed adjustment screw	Vis H de richesse à haut régime
24	4134 122 6801	1	Leerlaufstellschraube (1,2)	Low speed adjustment screw (1,2)	Vis L de richesse au ralenti (1,2)
25	4134 122 6802	1	Leerlaufstellschraube (3,4,5,6)	Low speed adjustment screw (3,4,5,6)	Vis L de richesse au ralenti (3,4,5,6)
26	1123 121 7800	1	Sieb	Strainer	Tamis
27	4180 122 6200	1	Leerlaufanschlagschraube	Idle speed adjustment screw	Vis de réglage de régime de ralenti
28	1120 122 7400	1	Halbrundschrabe	Round head screw	Vis à tête ronde
29	4134 121 3302	1	Drosselklappe	Throttle shutter	Papillon
30	1125 122 4200	1	Kugel	Ball	Bille
31	4119 122 3002	1	Feder	Spring	Ressort
32	4119 122 4200	1	Kugel	Ball	Bille
33	4128 121 2900	1	Startklappe	Choke shutter	Volet de démarrage
34	1125 122 7403	1	Halbrundschrabe	Round head screw	Vis à tête ronde
35	4229 121 2701	1	Kappe	Cap	Capuchon
36	1132 121 5640	1	Festdüse 0.40	Fixed jet 0.40	Gicleur fixe 0.40

(1) FS 120, (2) FS 120 R, (3) FS 200, (4) FS 200 R, (5) FS 250, (6) FS 250 R

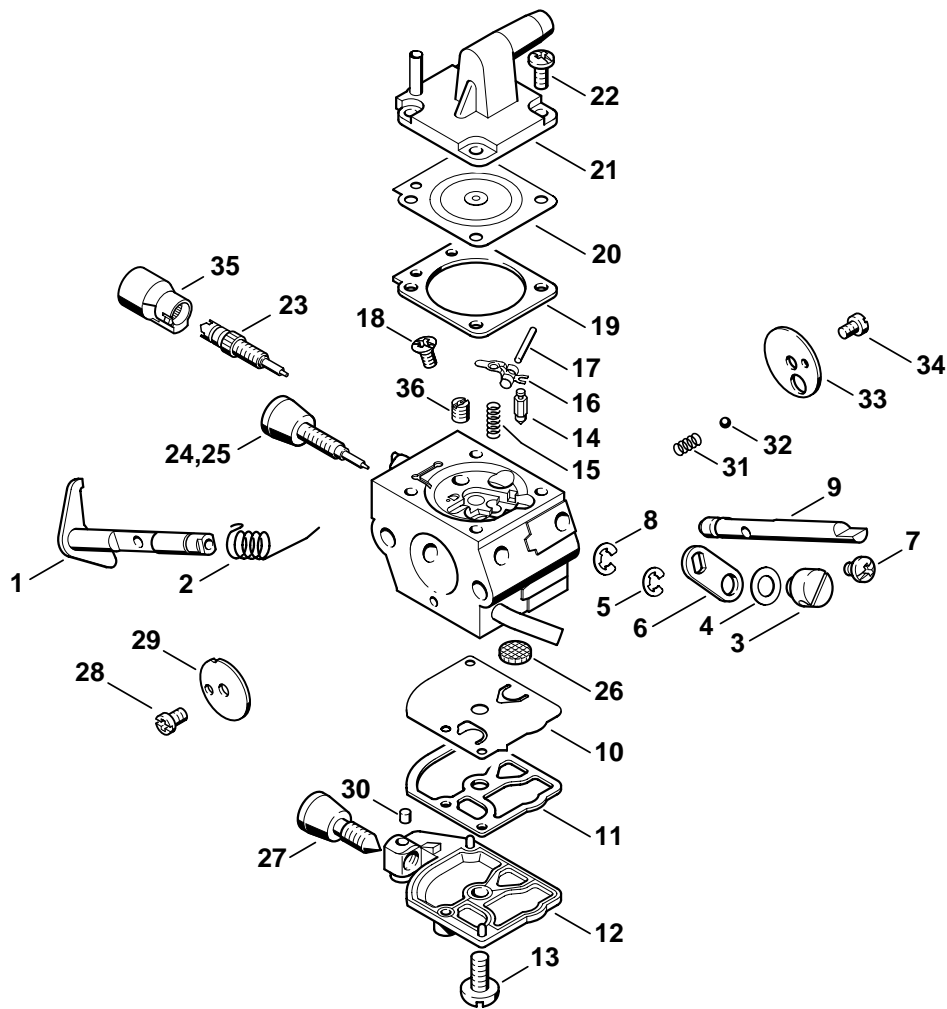

250ET034 SC

Illustration G

Vergaser C1Q-S82,
C1Q-S83

Carburetor C1Q-S82,
C1Q-S83

Carburateur C1Q-S82,
C1Q-S83

Bild-Nr.	Teile-Nr.	St-Zahl	Benennung	Part Name	Désignation
	1129 007 1062	1	Satz Vergaserteile □ 10, 11, 19, 20	Set of carburetor parts □ 10, 11, 19, 20	Jeu de pièces de carburateur □ 10, 11, 19, 20

(1) FS 120, (2) FS 120 R, (3) FS 200, (4) FS 200 R, (5) FS 250, (6) FS 250 R

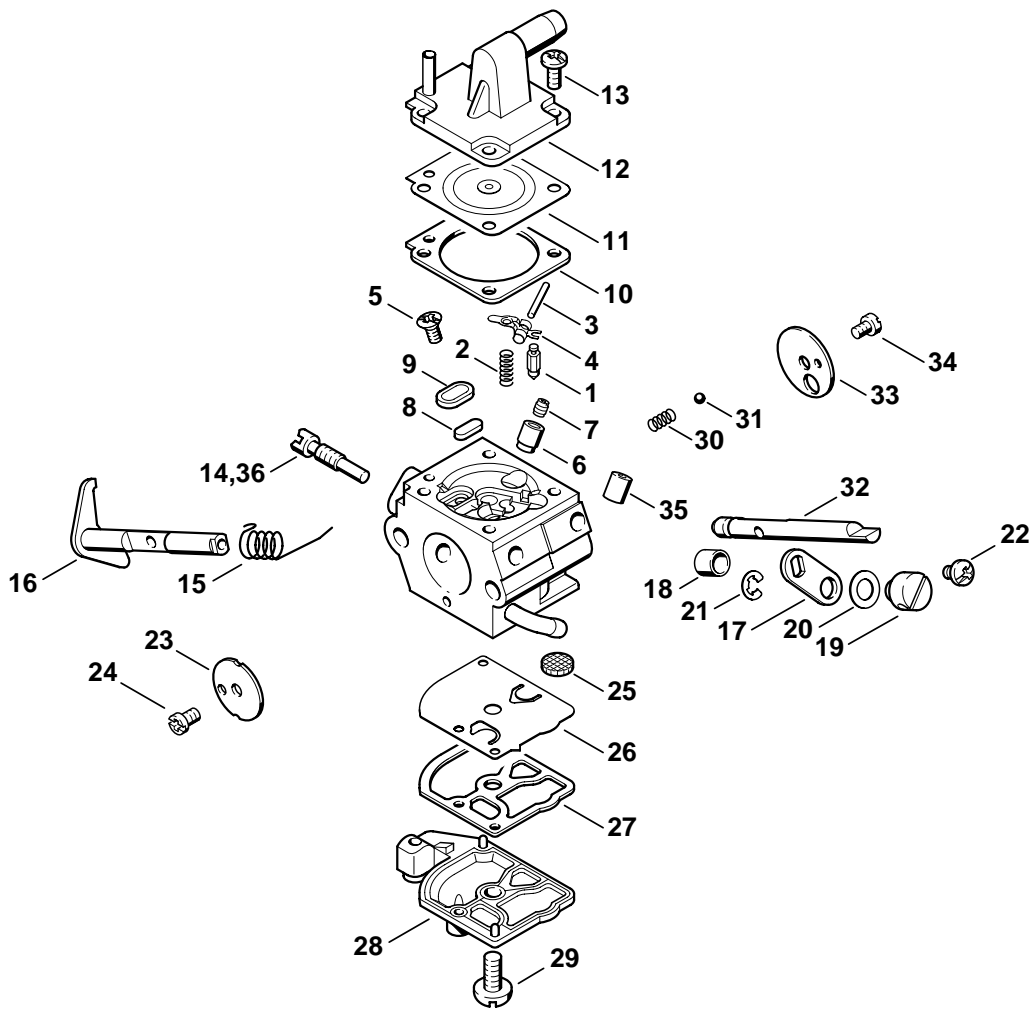

250ET025 SC

Illustration H

Vergaser C1Q-S51C,
C1Q-S36GCarburetor C1Q-S51C,
C1Q-S36GCarburateur C1Q-S51C,
C1Q-S36G

Bild-Nr.	Teile-Nr.	St-Zahl	Benennung	Part Name	Désignation
			(09.2003)	(09.2003)	(09.2003)
* 4134	120 0651	1	Vergaser C1Q-S51C □ 1 - 34	Carburetor C1Q-S51C □ 1 - 34	Carburateur C1Q-S51C □ 1 - 34
*		1	Vergaser C1Q-S36G (C) □ 1 - 5, 8 - 35	Carburetor C1Q-S36G (C) □ 1 - 5, 8 - 35	Carburateur C1Q-S36G (C) □ 1 - 5, 8 - 35
1 *	4116 121 5100	1	Einlassnadel	Inlet needle	Pointeau d'admission
2 *	1120 122 3004	1	Feder	Spring	Ressort
3 *	1120 121 9200	1	Achse	Spindle	Axe
4 *	1125 121 5000	1	Einlassregelhebel	Inlet control lever	Levier de réglage d'admission
5 *	1120 122 6600	1	Bundschraube	Collar screw	Vis à embase
6 *	4137 122 5100	1	Austrittsventil	Outlet valve	Soupape de sortie
7 *	1130 121 5601	1	Festdüse 0.44	Fixed jet 0.44	Gicleur fixe 0.44
8 *	4119 121 0700	1	Verschlussplatte	Cup plug	Plaque de fermeture
9 *	4129 121 0700	1	Verschlussplatte	Cup plug	Plaque de fermeture
10 *	4129 129 0902	1	Dichtung	Gasket	Joint
11 *	4129 121 4700	1	Regelmembrane	Metering diaphragm	Membrane de réglage
12 *	4134 121 0801	1	Abschlussdeckel	End cover	Couvercle
13 *	1120 122 6601	4	Bundschraube	Collar screw	Vis à embase
14 *	1130 122 6300	1	Leerlaufdrehzahlschraube	Idle speed adjustment screw	Vis de réglage de régime de ralenti
15 *	1123 122 3000	1	Feder	Spring	Ressort
16 *	4134 120 7100	1	Drosselwelle mit Hebel	Throttle shaft with lever	Axe de papillon avec levier
17 *	4134 123 7300	1	Hebel	Lever	Levier
18 *	4134 122 5000	1	Distanzhülse	Spacer sleeve	Douille d'écartement
19 *	4128 121 8900	1	Bolzen	Pin	Boulon
20 *	4137 121 8600	1	Scheibe	Washer	Rondelle
21 *	1120 122 9000	1	Sicherungsring	E-clip	Circlip
22 *	9079 319 0280	1	Schraube M3x3,5	Flat head screw M3x3.5	Vis à tête plate M3x3,5
23 *	1123 121 3300	1	Drosselklappe	Throttle shutter	Papillon
24 *	1120 122 7400	1	Halbrundschraube	Round head screw	Vis à tête ronde
25 *	1123 121 7800	1	Sieb	Strainer	Tamis
26 *	1129 121 4800	1	Pumpenmembrane	Pump diaphragm	Membrane de pompe
27 *	1123 129 0905	1	Dichtung	Gasket	Joint
28 *	4128 121 0800	1	Abschlussdeckel	End cover	Couvercle
29 *	1120 122 7800	1	Linsensenkschraube	Oval head screw	Vis à tête bombée fraisée
30 *	4119 122 3002	1	Feder	Spring	Ressort
31 *	4119 122 4200	1	Kugel	Ball	Bille
32 *	4134 121 3000	1	Startwelle	Choke shaft	Axe de volet de démarrage
33 *	4128 121 2900	1	Startklappe	Choke shutter	Volet de démarrage
34 *	1125 122 7403	1	Halbrundschraube	Round head screw	Vis à tête ronde
35 *	4134 121 5402	1	Ventildüse	Valve jet	Gicleur à soupape
			(22.2001)	(22.2001)	(22.2001)
36 *	4128 122 6300	1	Leerlaufdrehzahlschraube	Idle speed adjustment screw	Vis de réglage de régime de ralenti
			(09.2003)	(09.2003)	(09.2003)

(1) FS 120, (2) FS 120 R, (3) FS 200, (4) FS 200 R, (5) FS 250, (6) FS 250 R

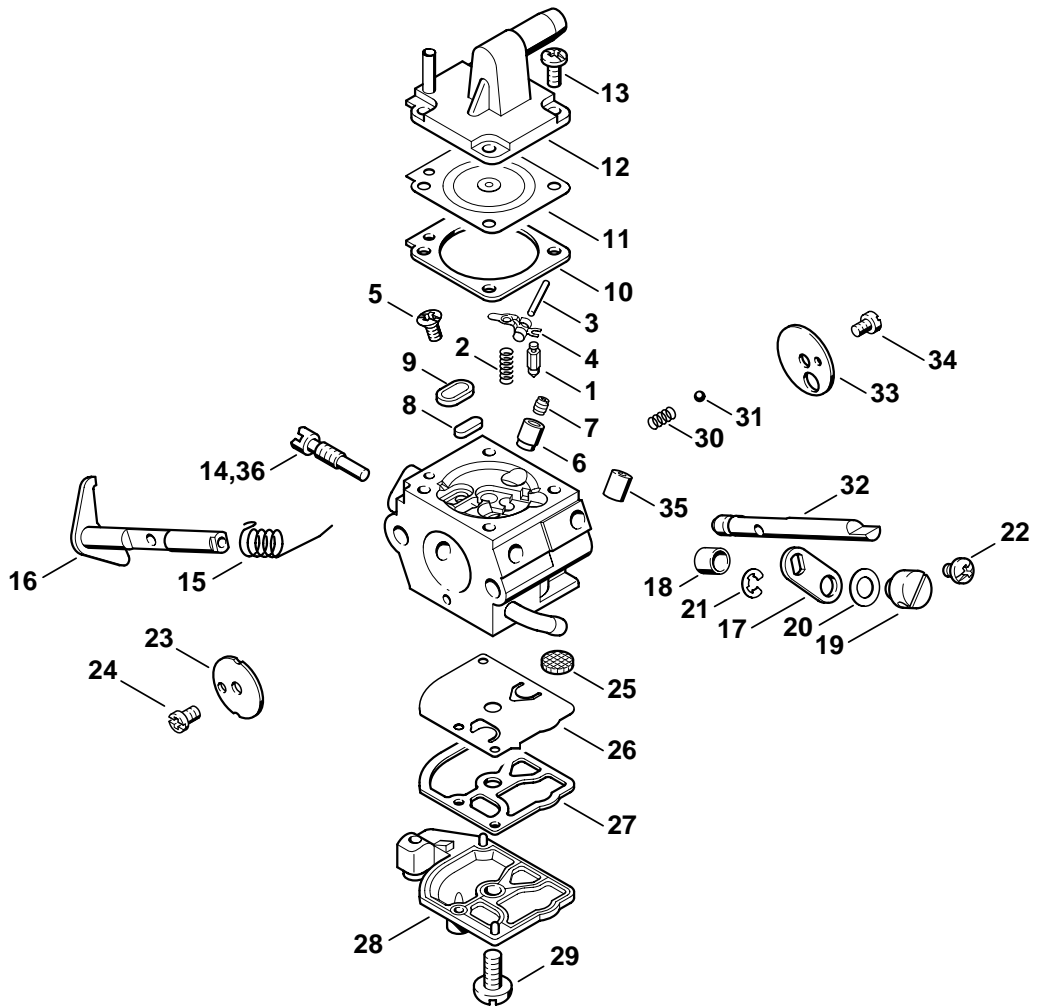

250ET025 SC

Illustration H

Vergaser C1Q-S51C,
C1Q-S36G

Carburetor C1Q-S51C,
C1Q-S36G

Carburateur C1Q-S51C,
C1Q-S36G

Bild-Nr.	Teile-Nr.	St-Zahl	Benennung	Part Name	Désignation
	* 4134 007 1060	1	Satz Vergaserteile □ 1, 2, 4, 10, 11, 25 - 27	Set of carburetor parts □ 1, 2, 4, 10, 11, 25 - 27	Jeu de pièces de carburateur □ 1, 2, 4, 10, 11, 25 - 27

(1) FS 120, (2) FS 120 R, (3) FS 200, (4) FS 200 R, (5) FS 250, (6) FS 250 R

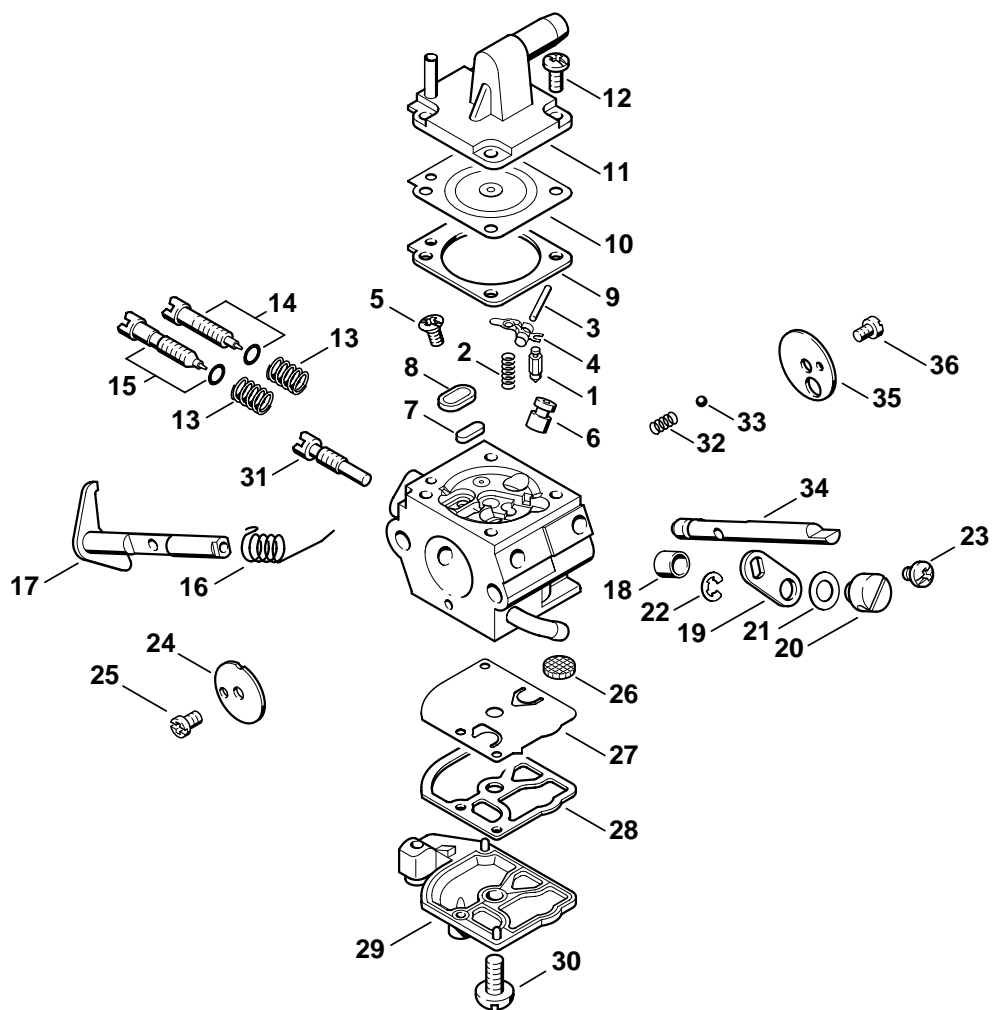

250ET005 SC

Illustration J

Vergaser C1Q-S35B

Carburetor C1Q-S35B

Carburateur C1Q-S35B

Bild-Nr.	Teile-Nr.	St-Zahl	Benennung	Part Name	Désignation
			(19.98)	(19.98)	(19.98)
*			Vergaser C1Q-S35B (C) □ 1 - 36	Carburetor C1Q-S35B (C) □ 1 - 36	Carburateur C1Q-S35B (C) □ 1 - 36
1 *	4116 121 5100	1	Einlassnadel	Inlet needle	Pointeau d'admission
2 *	1120 122 3004	1	Feder	Spring	Ressort
3 *	1120 121 9200	1	Achse	Spindle	Axe
4 *	1125 121 5000	1	Einlassregelhebel	Inlet control lever	Levier de réglage d'admission
5 *	1120 122 6600	1	Bundschrabe	Collar screw	Vis à embase
6 *	4132 121 5400	1	Ventildüse	Valve jet	Gicleur à soupape
7 *	1125 121 0700	1	Verschlussplatte	Cup plug	Plaque de fermeture
8 *	4129 121 0700	1	Verschlussplatte	Cup plug	Plaque de fermeture
9 *	4129 129 0902	1	Dichtung	Gasket	Joint
10 *	4129 121 4700	1	Regelmembrane	Metering diaphragm	Membrane de réglage
11 *	4134 121 0801	1	Abschlussdeckel	End cover	Couvercle
12 *	1120 122 6601	4	Bundschrabe	Collar screw	Vis à embase
13 *	1120 122 3005	2	Feder	Spring	Ressort
14 *	4128 122 6700	1	Hauptstellschraube	High speed adjustment screw	Vis H de richesse à haut régime
15 *	4134 122 6800	1	Leerlaufstellschraube	Low speed adjustment screw	Vis L de richesse au ralenti
16 *	1123 122 3000	1	Feder	Spring	Ressort
17 *	4134 120 7100	1	Drosselwelle mit Hebel	Throttle shaft with lever	Axe de papillon avec levier
18 *	4134 122 5000	1	Distanzhülse	Spacer sleeve	Douille d'écartement
19 *	4134 123 7300	1	Hebel	Lever	Levier
20 *	4128 121 8900	1	Bolzen	Pin	Boulon
21 *	4137 121 8600	1	Scheibe	Washer	Rondelle
22 *	1120 122 9000	1	Sicherungsring	E-clip	Circlip
23 *	9079 319 0280	1	Schraube M3x3,5	Flat head screw M3x3.5	Vis à tête plate M3x3,5
24 *	4134 121 3300	1	Drosselklappe	Throttle shutter	Papillon
25 *	1125 122 7403	1	Halbrundschrabe	Round head screw	Vis à tête ronde
26 *	1123 121 7800	1	Sieb	Strainer	Tamis
27 *	1129 121 4800	1	Pumpenmembrane	Pump diaphragm	Membrane de pompe
28 *	1123 129 0905	1	Dichtung	Gasket	Joint
29 *	4128 121 0800	1	Abschlussdeckel	End cover	Couvercle
30 *	1120 122 7800	1	Linsensenkschraube	Oval head screw	Vis à tête bombée fraisée
31 *	4128 122 6300	1	Leerlaufdrehzahlschraube	Idle speed adjustment screw	Vis de réglage de régime de ralenti
32 *	4119 122 3002	1	Feder	Spring	Ressort
33 *	4119 122 4200	1	Kugel	Ball	Bille
34 *	4134 121 3000	1	Startwelle	Choke shaft	Axe de volet de démarrage
35 *	4128 121 2900	1	Startklappe	Choke shutter	Volet de démarrage
36 *	1125 122 7403	1	Halbrundschrabe	Round head screw	Vis à tête ronde
*	4134 007 1060	1	Satz Vergaserteile □ 1, 2, 4, 9, 10, 26 - 28	Set of carburetor parts □ 1, 2, 4, 9, 10, 26 - 28	Jeu de pièces de carburateur □ 1, 2, 4, 9, 10, 26 - 28

(1) FS 120, (2) FS 120 R, (3) FS 200, (4) FS 200 R, (5) FS 250, (6) FS 250 R

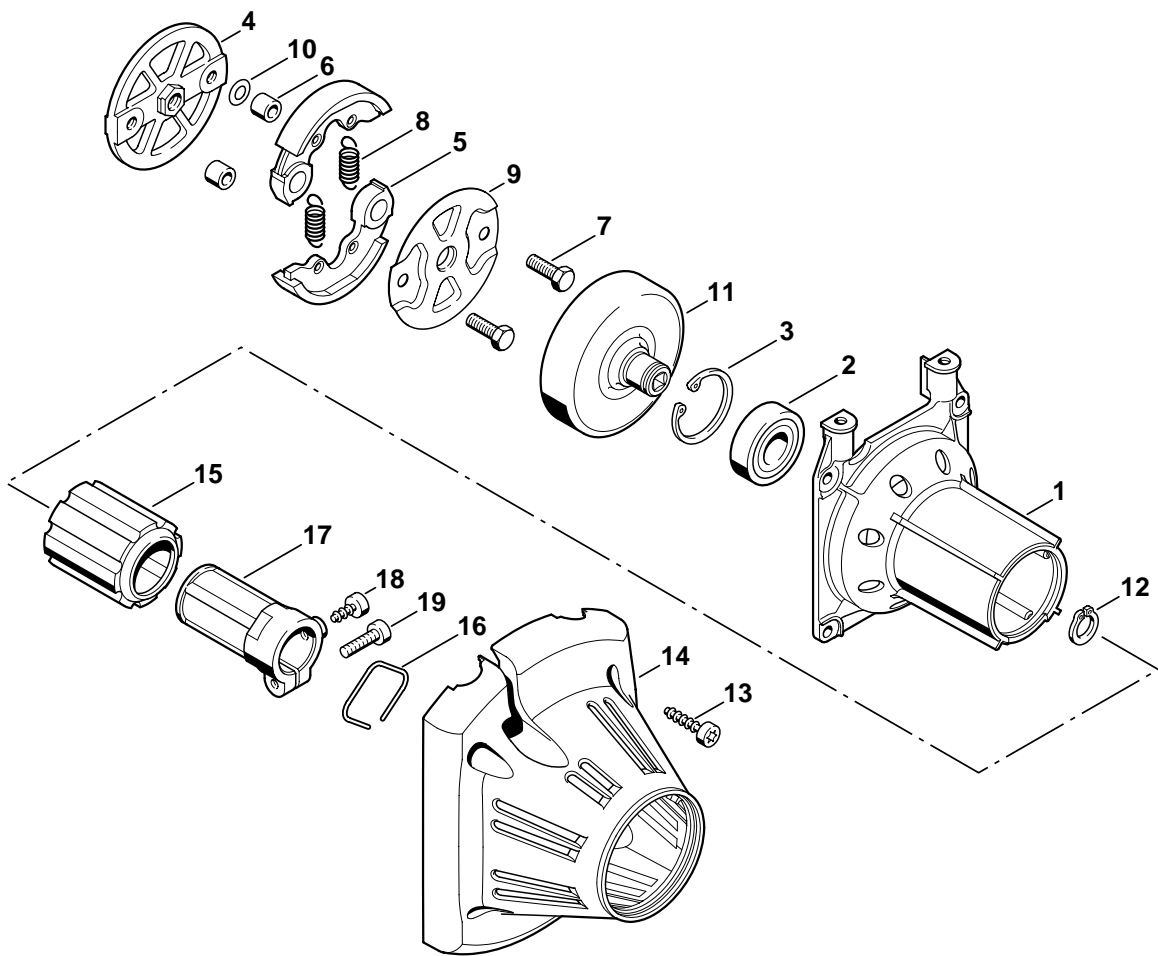

250ET033 GM

Illustration K

Kupplungsgehäuse

Clutch housing

Carter d'accouplement

Bild-Nr.	Teile-Nr.	St-Zahl	Benennung	Part Name	Désignation
1	4134 160 0601	1	Kupplungsgehäuse □ 2, 3	Clutch housing □ 2, 3	Carter d'accouplement □ 2, 3
2	9503 003 7450	1	Kugellager DIN625-6202-2RS	Grooved ball bearing 6202-2RS	Roulement rainuré à billes 6202-2RS
3	9456 621 3860	2	Sicherungsring DIN472-35x1,5	Circlip 35x1.5	Circlips 35x1,5
4	4128 160 2001	1	Kupplung □ 5 - 10	Clutch □ 5 - 10	Embrayage □ 5 - 10
5		2	Fliehk Gewicht (D)	Clutch shoe (D)	Masselotte (D)
6	0000 961 0608	2	Ring	Ring	Anneau
7	0000 951 0606	2	Sechskantschraube	Hexagon head screw	Vis à six pans
8	0000 997 5519	2	Zugfeder	Tension spring	Ressort de tension
9	4128 162 1000	1	Abdeckscheibe	Cover washer	Rondelle de recouvrement
10	0000 958 1000	2	Scheibe 16x10x0,5	Washer 16x10x0.5	Rondelle 16x10x0,5
11	4134 160 2900	1	Kupplungstrommel	Clutch drum	Cloche d'embrayage
12	9455 621 1520	1	Sicherungsring DIN471-15x1	Circlip 15x1	Circlips 15x1
13	9075 478 4159	4	Schraube IS-D5x24	Pan head self-tapping screw IS-D5x24	Vis cylindrique IS-D5x24
14	4134 160 0400	1	Kupplungshaube	Clutch shroud	Capot d'embrayage
15	4137 791 9300	1	Gummiement	Rubber insert	Pièce de caoutchouc
16	9457 621 4481	1	Sicherungsring	Circlip	Circlips
17	4137 790 7200	1	Hülse □ 18	Sleeve □ 18	Douille □ 18
18	9075 478 4095	1	Schraube IS-D5x12	Pan head self-tapping screw IS-D5x12	Vis cylindrique IS-D5x12
19	9022 371 1020	1	Schraube IS-M5x20-12.9	Spline screw IS-M5x20	Vis cylindrique IS-M5x20

(1) FS 120, (2) FS 120 R, (3) FS 200, (4) FS 200 R, (5) FS 250, (6) FS 250 R

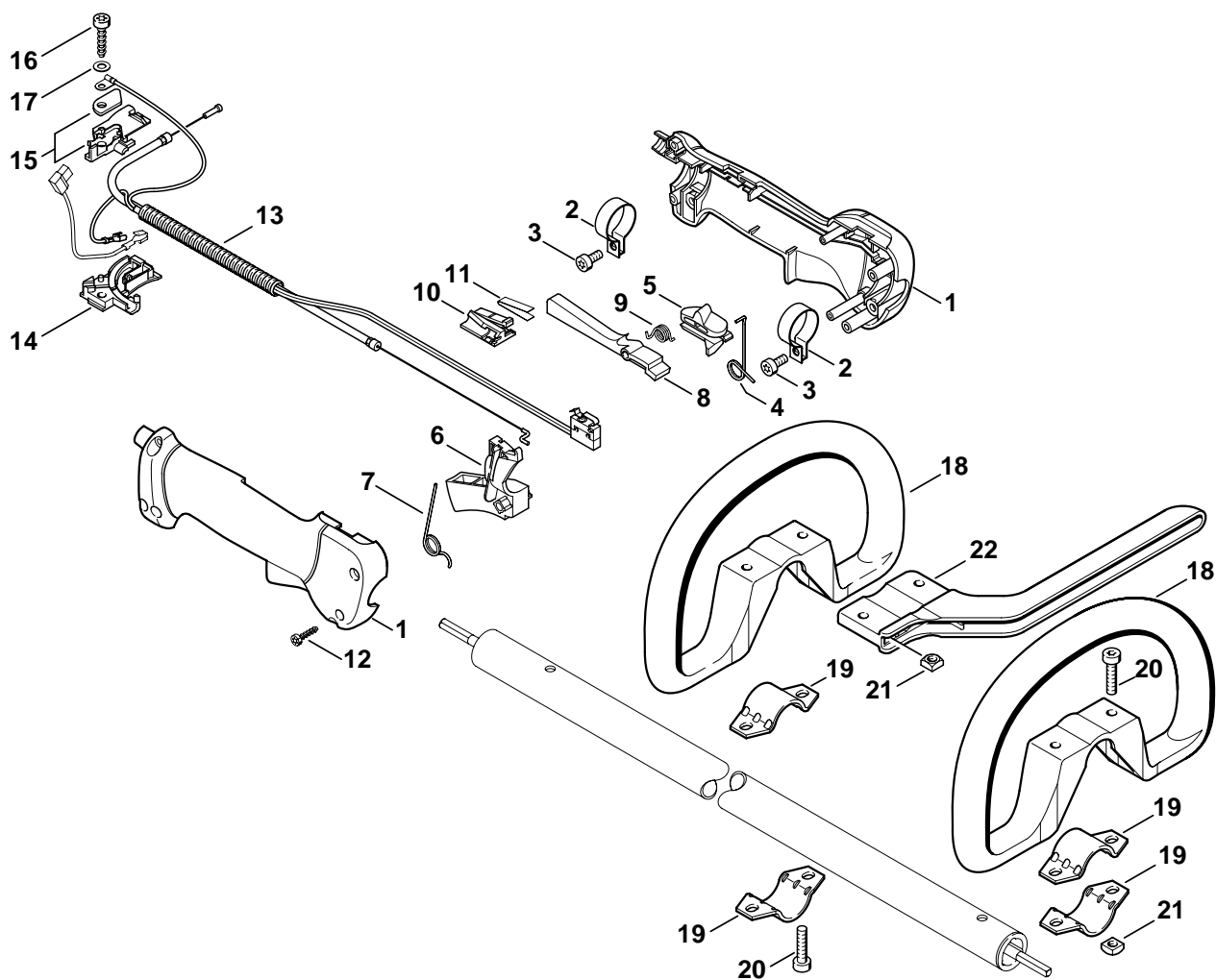

250ET036 SC

Illustration L

Bedienungsgriff

Control handle

Poignée de commande

Bild-Nr.	Teile-Nr.	St-Zahl	Benennung	Part Name	Désignation
	4137 790 1307	1	Bedienungsgriff (2,4,6) □ 1 - 12	Control handle (2,4,6) □ 1 - 12	Poignée de commande (2,4,6) □ 1 - 12
1	4137 790 0300	1	Handgriff (2,4,6)	Handle (2,4,6)	Poignée (2,4,6)
2	4137 791 9400	2	Spannschelle (2,4,6)	Hose clamp (2,4,6)	Collier de serrage (2,4,6)
3	9022 341 0960	2	Schraube IS-M5x12-10.9 (2,4,6)	Spline screw IS-M5x12 (2,4,6)	Vis cylindrique IS-M5x12 (2,4,6)
4	4137 182 4505	1	Schenkelfeder (2,4,6)	Torsion spring (2,4,6)	Ressort coudé (2,4,6)
5	4137 182 1701	1	Kombischieber (2,4,6)	Slide control (2,4,6)	Curseur combiné (2,4,6)
6	4137 182 1001	1	Gashebel (2,4,6)	Throttle trigger (2,4,6)	Manette des gaz (2,4,6)
7	4137 182 4504	1	Schenkelfeder (2,4,6)	Torsion spring (2,4,6)	Ressort coudé (2,4,6)
8	4137 182 0802	1	Sperrhebel (2,4,6)	Trigger interlock (2,4,6)	Levier d'arrêt (2,4,6)
9	4128 182 4501	1	Schenkelfeder (2,4,6)	Torsion spring (2,4,6)	Ressort coudé (2,4,6)
10	4128 793 3000	1	Schieber (2,4,6)	Slide (2,4,6)	Curseur (2,4,6)
11	4128 791 3100	1	Feder (2,4,6)	Spring (2,4,6)	Ressort (2,4,6)
12	9074 478 3025	4	Schraube IS-P4x16 (2,4,6)	Pan head self-tapping screw IS-P4x16 (2,4,6)	Vis cylindrique IS-P4x16 (2,4,6)
13	4134 180 1103	1	Gaszug (2,4,6)	Throttle cable (2,4,6)	Câble de commande des gaz (2,4,6)
14	4134 182 2104	1	Halter unten (2,4,6)	Support, bottom (2,4,6)	Crampon (2,4,6)
15	4134 180 6702	1	Halter (2,4,6)	Support (2,4,6)	Support (2,4,6)
16	9075 478 4159	1	Schraube IS-D5x24 (2,4,6)	Pan head self-tapping screw IS-D5x24 (2,4,6)	Vis cylindrique IS-D5x24 (2,4,6)
17	9291 021 0120	1	Scheibe DIN125-A5,3 (2,4,6)	Washer 5.3 (2,4,6)	Rondelle 5,3 (2,4,6)
18	4130 790 1316	1	Rundumgriff (2,4,6) □ 19 - 21	Loop handle (2,4,6) □ 19 - 21	Poignée circulaire (2,4,6) □ 19 - 21
19	4123 791 7400	2	Lasche (2,4,6)	Clamp (2,4,6)	Bride de fixation (2,4,6)
20	9022 341 1350	2	Schraube IS-M6x25-10.9 (2,4,6)	Spline screw IS-M6x25 (2,4,6)	Vis cylindrique IS-M6x25 (2,4,6)
21	9222 068 0900	2	Mutter DIN557-M6-5 (2,4,6)	Square nut M6 (2,4,6)	Ecrou à quatre pans M6 (2,4,6)
22	4130 791 4400	1	Bügel (2,4,6)	Barrier bar (2,4,6)	Etrier (2,4,6)

(1) FS 120, (2) FS 120 R, (3) FS 200, (4) FS 200 R, (5) FS 250, (6) FS 250 R

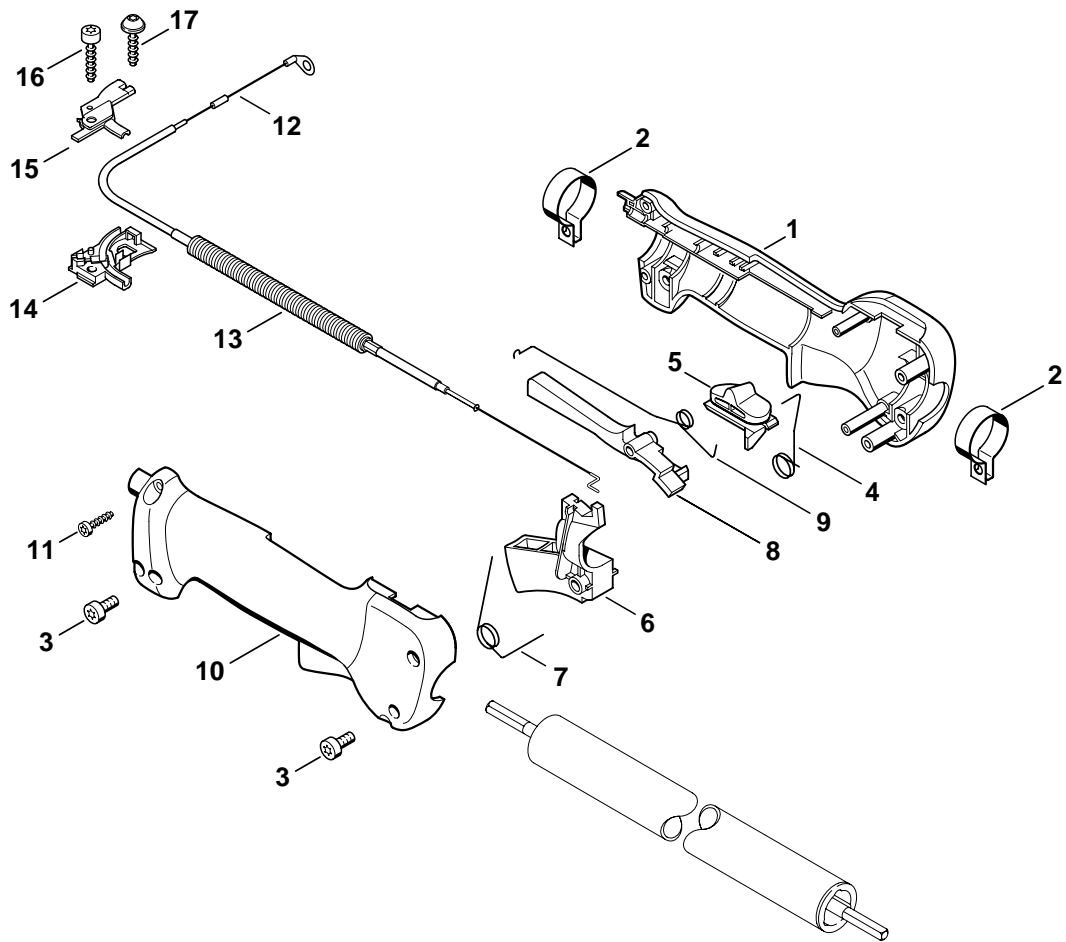

250ET040 GM

Illustration M

Bedienungsgriff

Control handle

Poignée de commande

Bild-Nr.	Teile-Nr.	St-Zahl	Benennung	Part Name	Désignation
			(09.2003)	(09.2003)	(09.2003)
	* 4137 790 1350	1	Bedienungsgriff (2,4,6) □ 1 - 11	Control handle (2,4,6) □ 1 - 11	Poignée de commande (2,4,6) □ 1 - 11
1	* 4137 790 1101	1	Griffhälfte innen (2,4,6)	Handle molding, inner (2,4,6)	Monture de poignée intérieure (2,4,6)
2	* 4137 791 9400	2	Spannschelle (2,4,6)	Hose clamp (2,4,6)	Collier de serrage (2,4,6)
3	* 9022 341 0960	2	Schraube IS-M5x12-10.9 (2,4,6)	Spline screw IS-M5x12 (2,4,6)	Vis cylindrique IS-M5x12 (2,4,6)
4	* 4137 442 1600	1	Kontaktfeder (2,4,6)	Contact spring (2,4,6)	Ressort de connexion (2,4,6)
5	* 4137 182 1700	1	Kombischieber (2,4,6)	Slide control (2,4,6)	Curseur combiné (2,4,6)
6	* 4137 182 1000	1	Gashebel (2,4,6)	Throttle trigger (2,4,6)	Manette des gaz (2,4,6)
7	* 4137 182 4500	1	Schenkelfeder (2,4,6)	Torsion spring (2,4,6)	Ressort coudé (2,4,6)
8	* 4137 182 0801	1	Sperrhebel (2,4,6)	Trigger interlock (2,4,6)	Levier d'arrêt (2,4,6)
9	* 4137 182 4502	1	Schenkelfeder (2,4,6)	Torsion spring (2,4,6)	Ressort coudé (2,4,6)
10	* 4137 791 0800	1	Griffhälfte außen (2,4,6)	Handle molding, outer (2,4,6)	Monture de poignée extérieure (2,4,6)
11	* 9074 478 3025	4	Schraube IS-P4x16 (2,4,6)	Pan head self-tapping screw IS-P4x16 (2,4,6)	Vis cylindrique IS-P4x16 (2,4,6)
12	* 4134 180 1107	1	Gaszug (2,4,6) □ 13	Throttle cable (2,4,6) □ 13	Câble de commande des gaz (2,4,6) □ 13
13	*	1	Schlauch 185 mm (D) (2,4,6)	Hose 185mm / 7 5/16" (D) (2,4,6)	Tuyau 185 mm (D) (2,4,6)
	* 4203 711 7201	1	Schlauch 960 mm (2,4,6)	Hose 960mm / 37 13/16" (2,4,6)	Tuyau 960 mm (2,4,6)
	* 4134 180 6700	1	Halter (2,4,6) □ 14 - 16	Support (2,4,6) □ 14 - 16	Support (2,4,6) □ 14 - 16
14	* 4134 182 2105	1	Halter unten (2,4,6)	Support, bottom (2,4,6)	Crampon (2,4,6)
15	* 4134 180 6701	1	Halter (2,4,6)	Support (2,4,6)	Support (2,4,6)
16	* 9075 478 4159	1	Schraube IS-D5x24 (2,4,6)	Pan head self-tapping screw IS-D5x24 (2,4,6)	Vis cylindrique IS-D5x24 (2,4,6)
			(22.2001)	(22.2001)	(22.2001)
17	* 0000 951 1100	1	Schraube IS-D5x20 (2,4,6)	Screw IS-D5x20 (2,4,6)	Vis cylindrique IS-D5x20 (2,4,6)

(1) FS 120, (2) FS 120 R, (3) FS 200, (4) FS 200 R, (5) FS 250, (6) FS 250 R

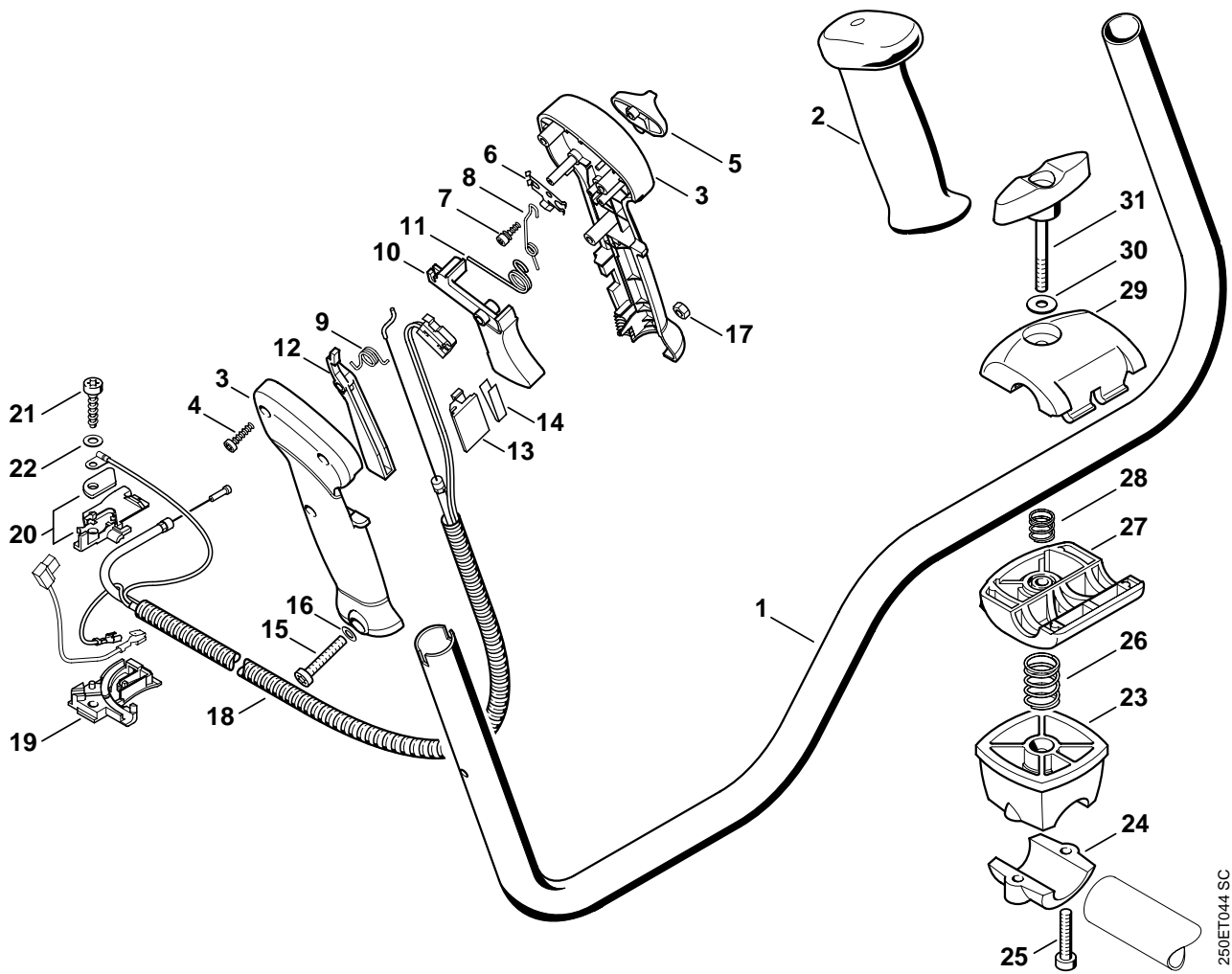

256ET044 SC

Illustration N

Zweihandgriff

Two-handed handle bar

Poignée tubulaire à deux mains

Bild-Nr.	Teile-Nr.	St-Zahl	Benennung	Part Name	Désignation
1	4128 790 1701	1	Griffrohr (1,3,5) □ 2	Handlebar (1,3,5) □ 2	Poignée tubulaire (1,3,5) □ 2
2	4128 791 0300	1	Handgriff links (1,3,5)	Handle, left (1,3,5)	Poignée gauche (1,3,5)
	4128 790 1301	1	Bedienungsgriff (1,3,5) □ 3 - 15, 17	Control handle (1,3,5) □ 3 - 15, 17	Poignée de commande (1,3,5) □ 3 - 15, 17
3	4128 790 0301	1	Handgriff rechts (1,3,5)	Handle, right (1,3,5)	Poignée droite (1,3,5)
4	9074 478 3025	3	Schraube IS-P4x16 (1,3,5)	Pan head self-tapping screw IS-P4x16 (1,3,5)	Vis cylindrique IS-P4x16 (1,3,5)
5	4128 182 1700	1	Kombischieber (1,3,5)	Slide control (1,3,5)	Curseur combiné (1,3,5)
6	4128 182 4201	1	Rastfeder (1,3,5)	Detent spring (1,3,5)	Ressort d'encliquetage (1,3,5)
7	4128 182 6200	1	Bundschraube (1,3,5)	Collar screw (1,3,5)	Vis à embase (1,3,5)
8	4128 182 4502	1	Schenkelfeder (1,3,5)	Torsion spring (1,3,5)	Ressort coudé (1,3,5)
9	4128 182 4501	1	Schenkelfeder (1,3,5)	Torsion spring (1,3,5)	Ressort coudé (1,3,5)
10	4128 182 1000	1	Gashebel (1,3,5)	Throttle trigger (1,3,5)	Manette des gaz (1,3,5)
11	4128 182 4500	1	Schenkelfeder (1,3,5)	Torsion spring (1,3,5)	Ressort coudé (1,3,5)
12	4128 182 0800	1	Sperrhebel (1,3,5)	Trigger interlock (1,3,5)	Levier d'arrêt (1,3,5)
13	4128 793 3000	1	Schieber (1,3,5)	Slide (1,3,5)	Curseur (1,3,5)
14	4128 791 3100	1	Feder (1,3,5)	Spring (1,3,5)	Ressort (1,3,5)
15	9022 346 1070	1	Schraube IS-M5x30x22-10.9 (1,3,5)	Spline screw IS-M5x30 (1,3,5)	Vis cylindrique IS-M5x30 (1,3,5)
16 *	9291 021 0120	1	Scheibe DIN125-A5,3 (1,3,5)	Washer 5.3 (1,3,5)	Rondelle 5,3 (1,3,5)
17	9214 320 0700	1	Sicherungsmutter DIN980-V M5-10 (1,3,5)	Lock nut M5 (1,3,5)	Ecrou de sécurité M5 (1,3,5)
18	4128 180 1104	1	Gaszug (1,3,5)	Throttle cable (1,3,5)	Câble de commande des gaz (1,3,5)
19	4134 182 2104	1	Halter unten (1,3,5)	Support, bottom (1,3,5)	Crampon (1,3,5)
20	4134 180 6702	1	Halter (1,3,5)	Support (1,3,5)	Support (1,3,5)
21	9075 478 4159	1	Schraube IS-D5x24 (1,3,5)	Pan head self-tapping screw IS-D5x24 (1,3,5)	Vis cylindrique IS-D5x24 (1,3,5)
22	9291 021 0120	1	Scheibe DIN125-A5,3 (1,3,5)	Washer 5.3 (1,3,5)	Rondelle 5,3 (1,3,5)
	4134 790 3200	1	Griffrohrhalter (1,3,5) □ 23 - 31	Handlebar support (1,3,5) □ 23 - 31	Crampon de tube de poignée (1,3,5) □ 23 - 31
23	4134 790 7600	1	Stütze (1,3,5)	Support (1,3,5)	Support (1,3,5)
24	4134 791 0900	1	Klemmschale (1,3,5)	Clamp (1,3,5)	Élément de serrage (1,3,5)
25	9022 341 1370	2	Schraube IS-M6x30-10.9 (1,3,5)	Spline screw IS-M6x30 (1,3,5)	Vis cylindrique IS-M6x30 (1,3,5)
26	0000 997 1701	1	Druckfeder (1,3,5)	Compression spring (1,3,5)	Ressort de pression (1,3,5)
27	4128 791 0905	1	Klemmschale unten (1,3,5)	Clamp, base (1,3,5)	Monture de serrage inférieure (1,3,5)
28	0000 997 1304	1	Druckfeder (1,3,5)	Compression spring (1,3,5)	Ressort de pression (1,3,5)
29	4128 791 0900	1	Klemmschale oben (1,3,5)	Clamp, top (1,3,5)	Monture de serrage supérieure (1,3,5)
30	0000 958 0609	1	Scheibe (1,3,5)	Washer (1,3,5)	Rondelle (1,3,5)
31	4128 790 7500	1	Knebelschraube (1,3,5)	Tommy screw (1,3,5)	Vis à garrot (1,3,5)

(1) FS 120, (2) FS 120 R, (3) FS 200, (4) FS 200 R, (5) FS 250, (6) FS 250 R

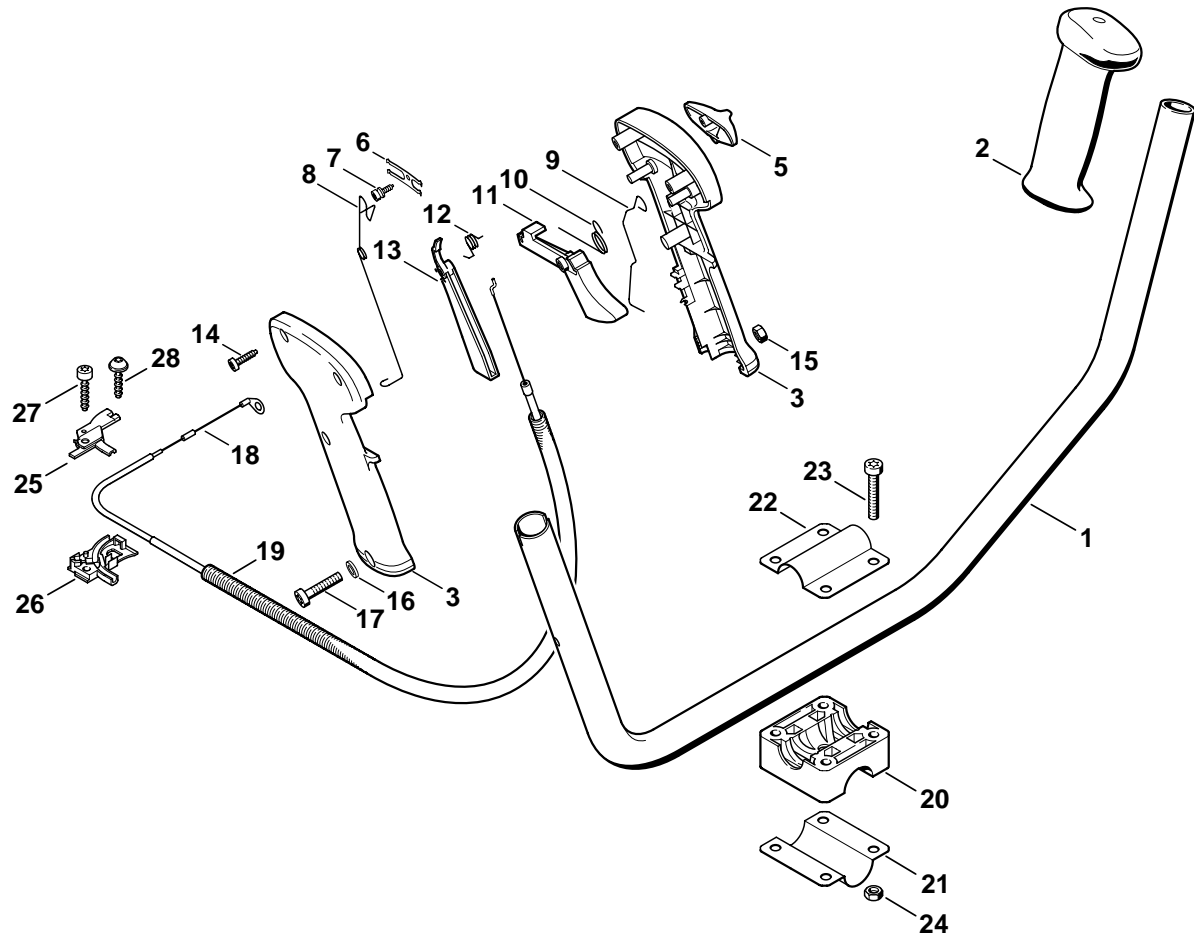

250ET029 GM

Illustration O

Zweihandgriff

Two-handed handle bar

Poignée tubulaire à deux mains

Bild-Nr.	Teile-Nr.	St-Zahl	Benennung	Part Name	Désignation
			(09.2003)	(09.2003)	(09.2003)
1 *	4137 790 1701	1	Griffrohr (1,3,5) □ 2	Handlebar (1,3,5) □ 2	Poignée tubulaire (1,3,5) □ 2
2 *	4128 791 0300	1	Handgriff links (1,3,5)	Handle, left (1,3,5)	Poignée gauche (1,3,5)
	* 4128 790 1300	1	Bedienungsgriff (1,3,5) □ 3 - 15, 17	Control handle (1,3,5) □ 3 - 15, 17	Poignée de commande (1,3,5) □ 3 - 15, 17
3 *	4128 790 0300	1	Handgriff rechts (1,3,5)	Handle, right (1,3,5)	Poignée droite (1,3,5)
5 *	4128 182 1700	1	Kombischieber (1,3,5)	Slide control (1,3,5)	Curseur combiné (1,3,5)
6 *	4128 182 4200	1	Rastfeder (1,3,5)	Detent spring (1,3,5)	Ressort d'encliquetage (1,3,5)
7 *	4128 182 6200	1	Bundschraube (1,3,5)	Collar screw (1,3,5)	Vis à embase (1,3,5)
8 *	4128 442 1600	1	Kontaktfeder (1,3,5)	Contact spring (1,3,5)	Ressort de connexion (1,3,5)
9 *	4128 442 1605	1	Kontaktfeder (1,3,5)	Contact spring (1,3,5)	Ressort de connexion (1,3,5)
10 *	4128 182 4500	1	Schenkelfeder (1,3,5)	Torsion spring (1,3,5)	Ressort coudé (1,3,5)
11 *	4128 182 1000	1	Gashebel (1,3,5)	Throttle trigger (1,3,5)	Manette des gaz (1,3,5)
12 *	4128 182 4501	1	Schenkelfeder (1,3,5)	Torsion spring (1,3,5)	Ressort coudé (1,3,5)
13 *	4128 182 0800	1	Sperrhebel (1,3,5)	Trigger interlock (1,3,5)	Levier d'arrêt (1,3,5)
14 *	9074 478 3025	3	Schraube IS-P4x16 (1,3,5)	Pan head self-tapping screw IS-P4x16 (1,3,5)	Vis cylindrique IS-P4x16 (1,3,5)
15 *	9214 320 0700	1	Sicherungsmutter DIN980-V M5-10 (1,3,5)	Lock nut M5 (1,3,5)	Ecrou de sécurité M5 (1,3,5)
16 *	9291 021 0120	1	Scheibe DIN125-A5,3 (1,3,5)	Washer 5.3 (1,3,5)	Rondelle 5,3 (1,3,5)
17 *	9022 346 1070	1	Schraube IS-M5x30x22-10.9 (1,3,5)	Spline screw IS-M5x30 (1,3,5)	Vis cylindrique IS-M5x30 (1,3,5)
18 *	4134 180 1100	1	Gaszug (1,3,5) □ 19	Throttle cable (1,3,5) □ 19	Câble de commande des gaz (1,3,5) □ 19
19 *		1	Schlauch 765 mm (D) (1,3,5)	Hose 765mm / 30 1/8" (D) (1,3,5)	Tuyau 765 mm (D) (1,3,5)
	* 4203 711 7201	1	Schlauch 960 mm (1,3,5)	Hose 960mm / 37 13/16" (1,3,5)	Tuyau 960 mm (1,3,5)
20 *	4137 791 6800	1	Klemmstück (1,3,5)	Clamp (1,3,5)	Pièce de serrage (1,3,5)
21 *	4130 791 0606	1	Klemmschale (1,3,5)	Clamp (1,3,5)	Monture de serrage (1,3,5)
22 *	4137 791 0900	1	Klemmschale (1,3,5)	Clamp (1,3,5)	Monture de serrage (1,3,5)
23 *	9022 341 1380	4	Schraube IS-M6x35-10.9 (1,3,5)	Spline screw IS-M6x35 (1,3,5)	Vis cylindrique IS-M6x35 (1,3,5)
24 *	9210 319 0900	4	Mutter DIN934-M6-10 (1,3,5)	Hexagon nut M6 (1,3,5)	Ecrou à six pans M6 (1,3,5)
	* 4134 180 6700	1	Halter (1,3,5) □ 25 - 27	Support (1,3,5) □ 25 - 27	Support (1,3,5) □ 25 - 27
25 *	4134 180 6701	1	Halter (1,3,5)	Support (1,3,5)	Support (1,3,5)
26 *	4134 182 2105	1	Halter unten (1,3,5)	Support, bottom (1,3,5)	Crampon (1,3,5)
27 *	9075 478 4159	1	Schraube IS-D5x24 (1,3,5)	Pan head self-tapping screw IS-D5x24 (1,3,5)	Vis cylindrique IS-D5x24 (1,3,5)
			(22.2001)	(22.2001)	(22.2001)
28 *	0000 951 1100	1	Schraube IS-D5x20 (1,3,5)	Screw IS-D5x20 (1,3,5)	Vis cylindrique IS-D5x20 (1,3,5)

(1) FS 120, (2) FS 120 R, (3) FS 200, (4) FS 200 R, (5) FS 250, (6) FS 250 R

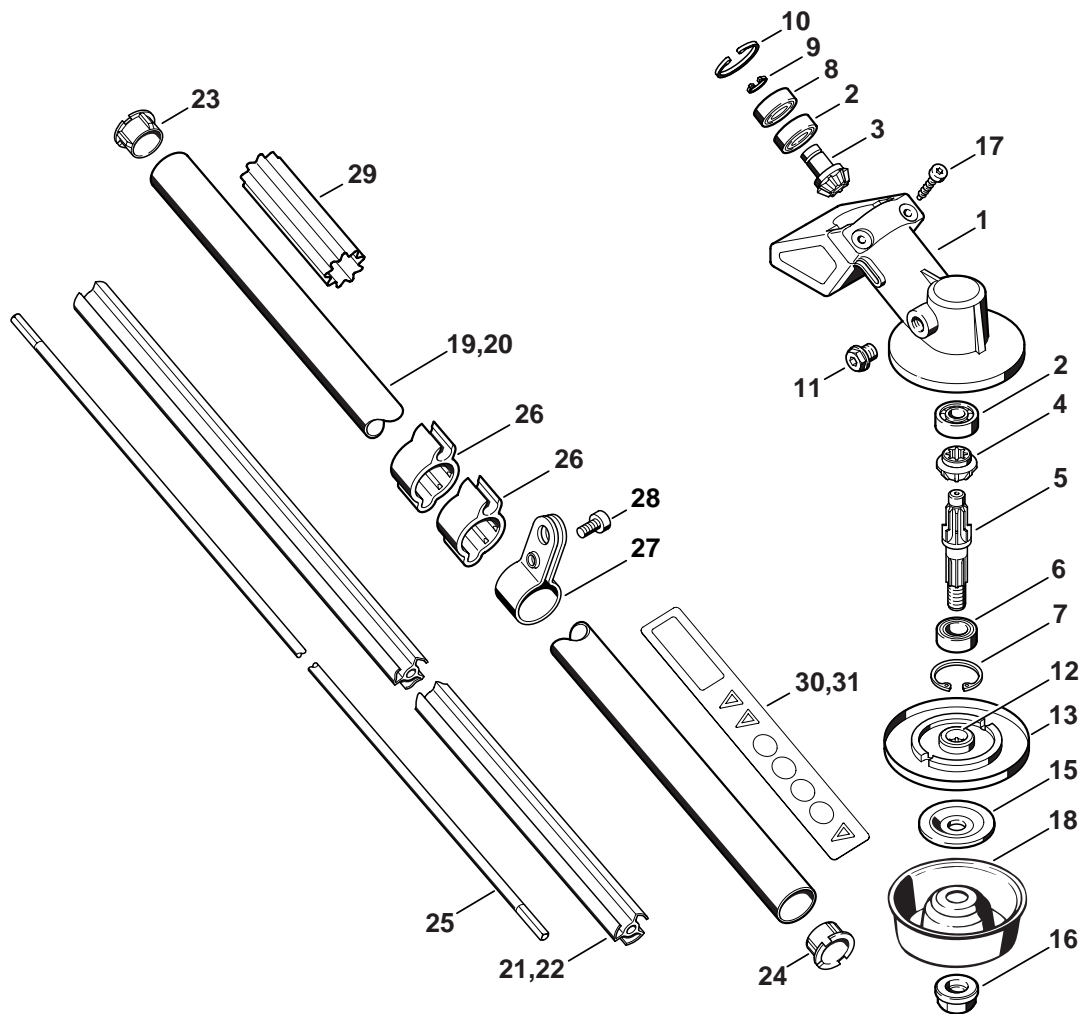

250ET031 GM

Illustration P

Getriebe

Gear head

Réducteur

Bild-Nr.	Teile-Nr.	St-Zahl	Benennung	Part Name	Désignation
	4137 640 0100	1	Getriebe □ 1 - 17	Gear head □ 1 - 17	Réducteur □ 1 - 17
1	4130 641 0305	1	Getriebegehäuse	Gear housing	Carter de réducteur
2	9503 003 9850	2	Kugellager DIN625-609	Grooved ball bearing 609	Roulement rainuré à billes 609
	4130 640 7301	1	Ritzelsatz □ 3, 4	Set of pinions □ 3, 4	Jeu de pignons □ 3, 4
3		1	Antriebsritzel (D)	Drive pinion (D)	Pignon d'entraînement (D)
4		1	Tellerrad (D)	Spur bevel gear (D)	Pignon denté (D)
5	4130 642 0601	1	Abtriebswelle	Drive shaft	Arbre de sortie
6	9503 003 5190	1	Kugellager DIN625-6001-2RS	Grooved ball bearing 6001-2RS	Roulement rainuré à billes 6001-2RS
7	9456 621 3100	1	Sicherungsring DIN472-28x1,2	Circlip 28x1.2	Circlips 28x1,2
8	9503 003 9853	1	Kugellager DIN625-609-2Z	Grooved ball bearing 609-2Z	Roulement rainuré à billes 609-2Z
9	9455 621 0750	1	Sicherungsring DIN471-9x1	Circlip 9x1	Circlips 9x1
10	9456 621 2660	1	Sicherungsring DIN472-24x1,2	Circlip 24x1.2	Circlips 24x1,2
11	4119 713 6500	1	Verschlussschraube	Screw plug	Bouchon fileté
12	4137 710 3800	1	Druckteller □ 13	Thrust plate □ 13	Disque de pression □ 13
13	4112 717 2801	1	Schutzscheibe	Guard washer	Rondelle de protection
15	4130 713 1600	1	Druckscheibe	Thrust washer	Rondelle de pression
16	4126 642 7600	1	Bundsicherungsmutter M10x1 links	Collar nut M10x1 l/h thread	Ecrou à embase M10x1 à gauche
17	9075 478 4159	2	Schraube IS-D5x24	Pan head self-tapping screw IS-D5x24	Vis cylindrique IS-D5x24
18	4126 713 3100	1	Laufsteller (B)	Rider plate (B)	Disque porteur (B)

(1) FS 120, (2) FS 120 R, (3) FS 200, (4) FS 200 R, (5) FS 250, (6) FS 250 R

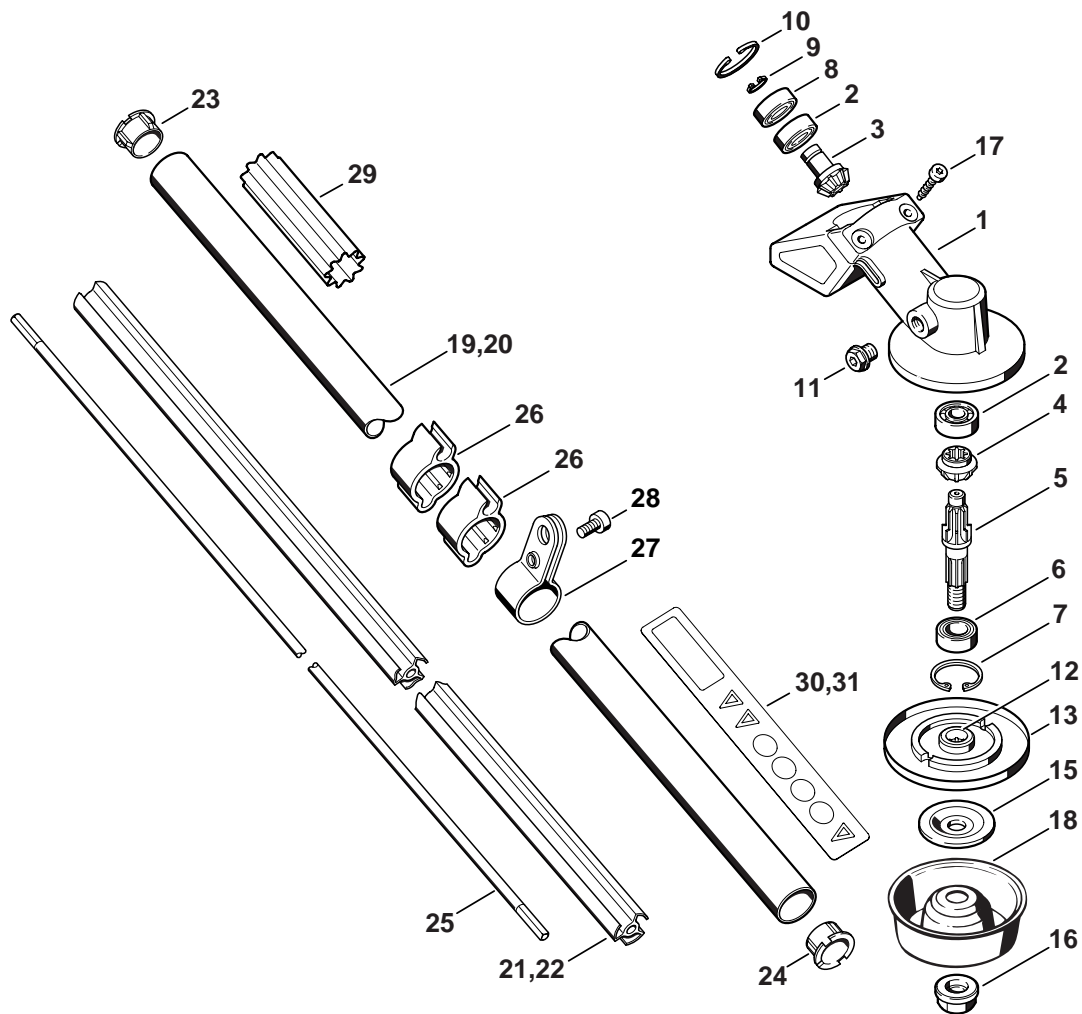

250ET031 GM

Illustration P

Getriebe

Gear head

Réducteur

Bild-Nr.	Teile-Nr.	St-Zahl	Benennung	Part Name	Désignation
19	4137 710 7136	1	Schaft Ø 25,4 mm □ 21, 23, 30	Drive tube assembly Ø 25.4mm / 1" □ 21, 23, 30	Tube complet Ø 25,4 mm □ 21, 23, 30
20	4137 710 7134	1	Schaft Ø 25,4 mm USA □ 21, 23, 31	Drive tube assembly Ø 25.4mm / 1" USA □ 21, 23, 31	Tube complet Ø 25,4 mm USA □ 21, 23, 31
21	4134 711 7303	1	Lagerrohr 1375 mm	Flexible liner 1375mm / 54 3/16"	Fourreau 1375 mm
22 *	4137 711 7300	1	(22.2001) Lagerrohr 1455 mm	(22.2001) Flexible liner 1455mm / 57 5/16"	(22.2001) Fourreau 1455 mm
23	4137 711 2101	1	Stopfen	Plug	Bouchon
24 *	4137 711 2101	1	(22.2001) Stopfen	(22.2001) Plug	(22.2001) Bouchon
25	4137 711 3200	1	Antriebswelle	Drive shaft	Arbre d'entraînement
26	4119 182 2110	2	Halter (1,3,5)	Support (1,3,5)	Crampon (1,3,5)
27	4140 007 1006	1	Satz Spannschelle □ 28	Hose clamp kit □ 28	Jeu de collier de serrage □ 28
28	9022 341 1270	1	Schraube IS-M6x14-10.9	Spline screw IS-M6x14	Vis cylindrique IS-M6x14
29	0000 711 2500	1	Hülse (2,4,6)	Sleeve (2,4,6)	Douille (2,4,6)
30	0000 967 3725	1	Warnhinweis Piktogramm FS	Warning pictogram FS	Pictogramme d'avertissement FS
31	0000 967 3684	1	Warnhinweis Piktogramm FS USA	Warning pictogram FS USA	Pictogramme d'avertissement FS USA
	0781 120 1117	1	Getriebefett (A,B)	Gear lubricant (A,B)	Graisse de réducteur (A,B)

(1) FS 120, (2) FS 120 R, (3) FS 200, (4) FS 200 R, (5) FS 250, (6) FS 250 R

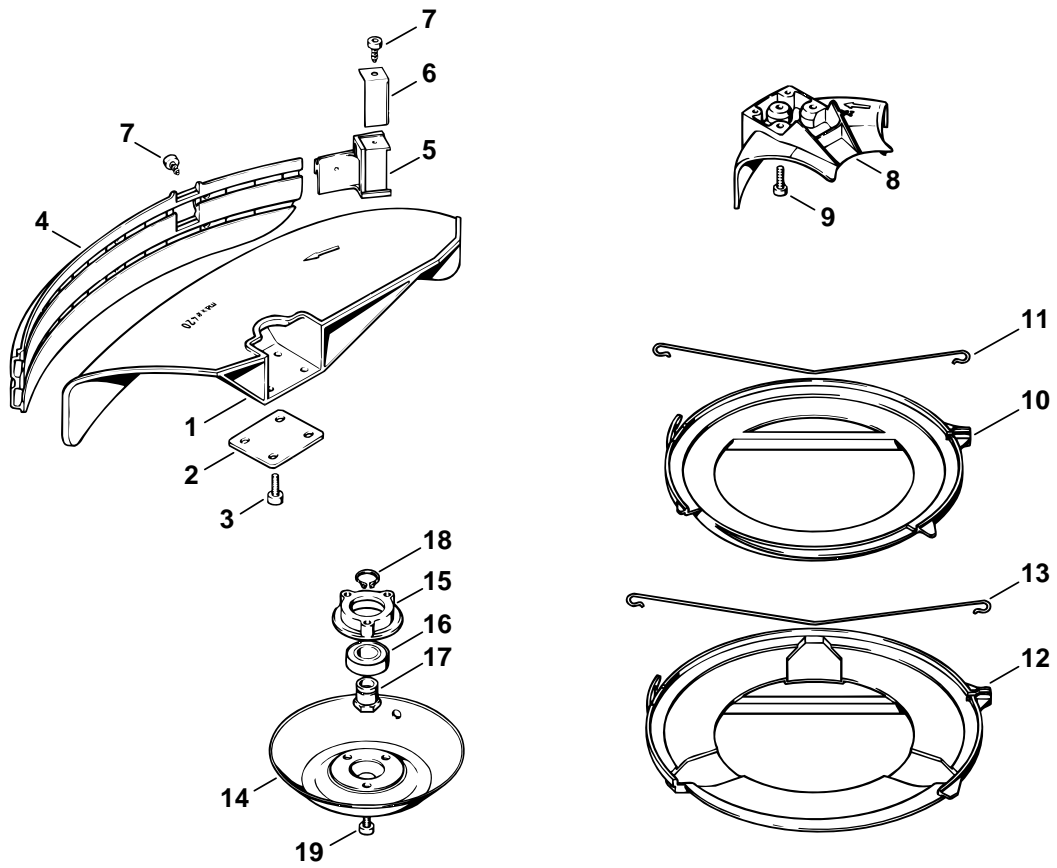

250ET039 GM

Illustration Q

Schutz

Deflector

Capot protecteur

Bild-Nr.	Teile-Nr.	St-Zahl	Benennung	Part Name	Désignation
	4119 007 1013	1	Satz Schutz □ 1 - 7	Deflector kit □ 1 - 7	Jeu de pièces de capot protecteur □ 1 - 7
1	4119 713 4500	1	Schutz	Deflector	Capot protecteur
2	4112 716 3100	1	Unterlage	Backing plate	Cale
3	9022 341 1010	4	Schraube IS-M5x18-10.9	Spline screw IS-M5x18	Vis cylindrique IS-M5x18
4	4119 716 3200	1	Schürze	Skirt	Tablier
5	4119 710 6000	1	Ablängmesser □ 6, 7	Blade □ 6, 7	Couteau □ 6, 7
6	4118 713 4105	1	Ablängmesser	Blade	Couteau
7	9074 478 4125	2	Schraube IS-5x14	Pan head self-tapping screw IS-5x14	Vis cylindrique IS 5x14
8	4117 710 8200	1	Anschlag Ø 200 (1,3,5) □ 9	Limit stop Ø 200 (1,3,5) □ 9	Butée Ø 200 (1,3,5) □ 9
9	9022 341 1010	3	Schraube IS-M5x18-10.9 (1,3,5)	Spline screw IS-M5x18 (1,3,5)	Vis cylindrique IS-M5x18 (1,3,5)
10	4119 790 3901	1	Transportschutz Ø 225 (1,3,5) □ 11	Transport guard Ø 225 (1,3,5) □ 11	Protecteur de transport Ø 225 (1,3,5) □ 11
11	4119 792 4300	1	Spannbügel (1,3,5)	Clamping wire (1,3,5)	Bride de fixation (1,3,5)
12	4119 790 3906	1	Transportschutz Ø 255 (1,3,5) □ 13	Transport guard Ø 255 (1,3,5) □ 13	Protecteur de transport Ø 255 (1,3,5) □ 13
13	4119 792 4305	1	Spannbügel (1,3,5)	Clamping wire (1,3,5)	Bride de fixation (1,3,5)
	4132 710 8500	1	Lauffeller (B) (1,3,5) □ 14 - 19	Rider plate (B) (1,3,5) □ 14 - 19	Disque porteur (B) (1,3,5) □ 14 - 19
14	4112 713 3100	1	Lauffeller (1,3,5)	Rider plate (1,3,5)	Disque porteur (1,3,5)
15	4132 713 1400	1	Lagerdeckel (1,3,5)	Bearing cover (1,3,5)	Couvercle de roulement (1,3,5)
16	9503 003 5330	1	Kugellager DIN625-6003-2RS (1,3,5)	Grooved ball bearing 6003-2RS (1,3,5)	Roulement rainuré à billes 6003-2RS (1,3,5)
17	4132 713 6800	1	Bundmutter (1,3,5)	Collar nut (1,3,5)	Ecrou à embase (1,3,5)
18	9455 621 1800	1	Sicherungsring DIN471-17x1 (1,3,5)	Circlip 17x1 (1,3,5)	Circlips 17x1 (1,3,5)
19	9022 341 1270	3	Schraube IS-M6x14-10.9 (1,3,5)	Spline screw IS-M6x14 (1,3,5)	Vis cylindrique IS-M6x14 (1,3,5)

(1) FS 120, (2) FS 120 R, (3) FS 200, (4) FS 200 R, (5) FS 250, (6) FS 250 R

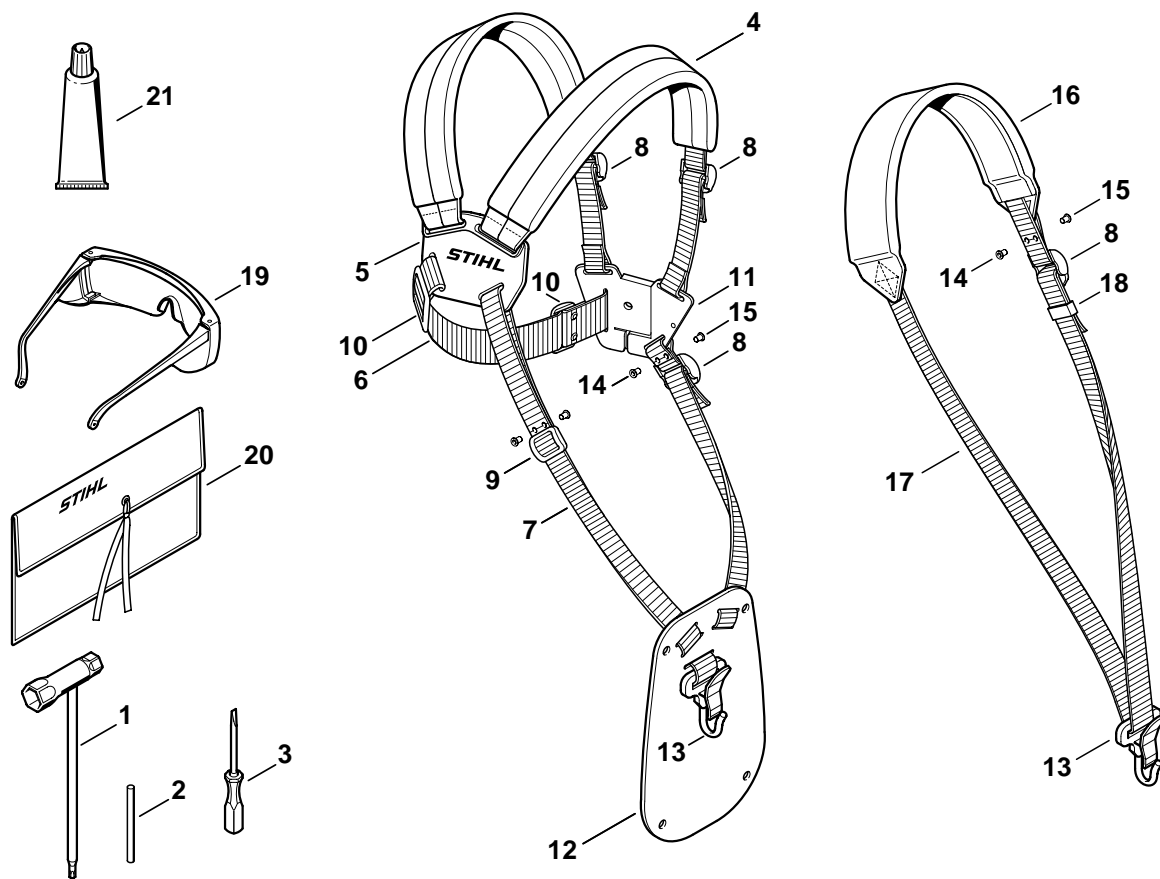

250ET032 GM

Illustration R

Werkzeuge, Sonderzubehör

Tools, Extras

Outils, Accessoires optionnels

Bild-Nr.	Teile-Nr.	St-Zahl	Benennung	Part Name	Désignation
1	4128 890 3400	1	Kombischlüssel	Combination wrench	Clé multiple
2	4130 893 7800	1	Steckdorn	Locking pin	Mandrin
3	0000 890 2300	1	Schraubendreher	Screwdriver	Tournevis
4	4119 710 9001	1	Doppelschultergurt □ 5 - 13	Full harness □ 5 - 13	Harnais □ 5 - 13
5	4119 710 6306	1	Rückenplatte mit Riemen	Backplate with strap	Plaque dorsale avec sangle
6		1	Riemen 38x680 mm	Strap 38x680mm / 1.5x26.8"	Sangle 38x680 mm
	0000 930 2242	1	Gurtband 38 mm x 5 m (A,B)	Webbing 38mm x 5m / 1.5x197" (A,B)	Sangle 38 mm x 5 m (A,B)
7		1	Riemen 25 mm x 1 m	Strap 25mm x 1m / 1x40"	Sangle 25 mm x 1 m
	0000 930 2241	1	Gurtband 25 mm x 10 m (A,B)	Webbing 25mm x 10m / 1" x 33' (A,B)	Sangle 25 mm x 10 m (A,B)
8	4203 792 7200	3	Klemmschieber	Slide	Boucle de réglage
9	4119 718 6300	1	Schieber	Slide	Boucle de réglage
10	4119 718 6310	2	Schieber	Slide	Boucle de réglage
11	4119 710 6406	1	Schloss mit Riemen	Buckle with strap	Fermeture avec sangle
12	4119 718 7400	1	Schutzplatte	Guard plate	Plaque de protection
13	4119 710 6906	1	Karabinerhaken	Spring safety hock	Mousqueton
14	9408 021 4530		Nietteil DIN7331-AN4x8x6 (Stückzahl nach Bedarf)	Rivet shank 4x8x6 (quantity as required)	Rivet, partie à riveter 4x8x6 (quantité suivant besoin)
15	9409 021 4420		Kopfteil DIN7331-K4x8 (Stückzahl nach Bedarf)	Rivet head 4x8 (quantity as required)	Rivet, partie tête 4x8 (quantité suivant besoin)
16	4119 710 9011	1	Traggurt □ 8, 13, 17, 18	Harness □ 8, 13, 17, 18	Harnais □ 8, 13, 17, 18
17		1	Riemen 25 mm x 1,86 m	Strap 25mm x 1.86m / 1x73"	Sangle 25 mm x 1,86 m
18	4119 718 6320	1	Schieber	Slide	Boucle de réglage
19	0000 884 0307	1	Schutzbrille	Safety glasses	Lunettes de protection
20	0000 891 0801	1	Werkzeugtasche (B)	Tool roll (B)	Pochette à outils (B)
21	0783 830 2000	1	Dichtungsmasse Dirko HT rot (B)	Tube of sealant Dirko HT red (B)	Tube de pâte d'étanchéité Dirko HT rouge (B)

(1) FS 120, (2) FS 120 R, (3) FS 200, (4) FS 200 R, (5) FS 250, (6) FS 250 R

- D** **Zeichenerklärung**
 = darin enthalten Bild-Nr
 * = Maschine älterer Bauart
 (A) = nicht abgebildet
 (B) = nur Sonderzubehör
 (C) = ab Werk nicht mehr lieferbar
 (D) = einzeln kein Ersatzteil
 (1,2,...) = Ausführungsarten
- E** **Aclaración de símbolos**
 = contiene núm. de ilustración
 * = máquinas de ejecución anterior
 (A) = sin ilustración
 (B) = sólo accesorios especiales
 (C) = ya no se suministra de fábrica
 (D) = la pieza suelta no se suministra como repuesto
 (1,2,...) = clases de ejecución
- FR** **Merkkien selitys**
 = johon sisältyvät kuvan numerot
 * = vanhemmanmalliset koneet
 (A) = ei kuvassa
 (B) = ainoastaan lisävaruste
 (C) = ei toimiteta enää tehtaalta
 (D) = ei toimiteta erikseen
 (1,2,...) = Mallit
- N** **Tegnforklaring**
 = medfølger fig. nr
 * = Maskiner av eldre modell
 (A) = ikke avbildet
 (B) = bare ekstrautstyr
 (C) = leveres ikke lenger fra fabrikk
 (D) = enkeltdele leveres ikke som reservedel
 (1,2,...) = utførelser
- P** **Explicação dos símbolos**
 = Incl. a fig. No.
 * = Máquinas de construção mais antiga
 (A) = não ilustrado
 (B) = unicamente acessórios especiais
 (C) = já não fornecível ex-fábrica
 (D) = a peça individual não é nenhuma peça de reposição
 (1,2,...) = Configurações
- TR** **İşaret açıklaması**
 = İndeks numarada dahildir
 * = Eski model makinalar
 (A) = Şemada yoktur
 (B) = Ekstradır
 (C) = Fabrikadan artık temin edilmez
 (D) = Ayırı verilmmez
 (1,2,...) = Mevcut modeller
- BR** **Explicação dos símbolos**
 = inclusive fig. n.
 * = máquinas antigas
 (A) = não ilustrado
 (B) = somente acessórios especiais
 (C) = não mais fornecido pela fábrica
 (D) = não fornecida separadamente
 (1,2,...) = diferentes versões
- DE** **Key to symbols**
 = including item No.
 * = previous Models
 (A) = not illustrated
 (B) = option
 (C) = no longer available from factory
 (D) = not available as separate item
 (1,2,...) = versions available
- HR** **Tumač znakova**
 = u istom sadrži dijelove, slike br.
 * = strojevi starije izvedbe
 (A) = nedostaje slika
 (B) = samo kao poseban pribor
 (C) = više se ne isporučuje fco tvornica
 (D) = ne isporučuje se pojedinačno kao pričuvni dio
 (1,2,...) = vrste izvedbi
- I** **Leggenda**
 = comprendente fig(g). n.
 * = Macchine di costruzione anteriore
 (A) = non illustrato
 (B) = fornibile soltanto a richiesta
 (C) = non più fornibile dallo stabilimento
 (D) = niente ricambio
 (1,2,...) = versioni
- CZ** **Vysvětlivky**
 = obsahuje obr. č.
 * = stroje starší konstrukce
 (A) = není vyobrazeno
 (B) = jen zvláštní příslušenství
 (C) = ze závodu se již nedodává
 (D) = jednotlivě žádný náhradní díl
 (1,2,...) = druhy provedení
- NL** **Toelichting symbolen**
 = daarin begrepen pos.nr.
 * = machines van een oudere uitvoering
 (A) = niet afgebeeld
 (B) = uitsluitend speciaal toebehoren
 (C) = af fabriek niet meer leverbaar
 (D) = niet los leverbaar
 (1,2,...) = uitvoeringen
- PL** **Objaśnienie znaków**
 = zawiera rysunki nr.
 * = maszyny starszego typu budowy
 (A) = nie zilustrowano
 (B) = tylko jako wyposażenie specjalne
 (C) = nie dostarczane przez producenta
 (D) = nie występuje jako samodzielna część zamienna
 (1,2,...) = rodzaj wykonania
- RO** **Legendă**
 = include figura nr.
 * = Utilaje de fabricație mai veche
 (A) = neilustrat
 (B) = doar ca accesoriu opțional
 (C) = nu se mai livrează din fabrică
 (D) = fără piesă de schimb separată
 (1,2,...) = diferite modele
- F** **Légende**
 = y compris Fig. No.
 * = machines d'ancienne construction
 (A) = non illustré
 (B) = uniquement accessoire optionnel
 (C) = n'est plus livrable départ usine
 (D) = n'est pas livrable séparément
 (1,2,...) = différentes exécutions
- S** **Teckenförklaring**
 = ingår bild-nr
 * = maskiner av tidigare utförande
 (A) = ej avbildat
 (B) = endast tillbehör
 (C) = levereras inte längre från fabriken
 (D) = ingen separat reservdel
 (1,2,...) = varianter
- DK** **Symbolforklaring**
 = inklusive fig. nr.
 * = maskiner af ældre konstruktion
 (A) = ikke afbilledet
 (B) = kun ekstratilbehør
 (C) = leveres ikke mere fra fabrik
 (D) = leveres ikke som løs reservedel
 (1,2,...) = modelbetegnelser
- H** **Jelmagyarázat**
 = abban tartalmazott ábra-szám
 * = Régebbi építéssorozatú gépek
 (A) = Nincs ábrázolva
 (B) = Csak külön tartozék
 (C) = Gyár már nem szállítja
 (D) = nem alkatrész, egyenként
 (1,2,...) = Kivitelezési módok
- GR** **Επεξήγηση συμβόλων**
 = περιλαμβάνει τον αριθμό του είδους
 * = Μηχανήματα παλαιότερων μοντέλων
 (A) = δεν απεικονίζεται
 (B) = μόνο προαιρετικά είδη
 (C) = δεν διατίθεται από τον κατασκευαστή
 (D) = δεν παραδίδεται ως ξεχωριστό είδος
 (1,2,...) = διαφορετικοί τύποι που διατίθενται
- RUS** **Пояснения к условным обозначениям**
 = сюда входят номера позиций
 * = машины более старого типа
 (A) = конструкции
 (B) = не изображено на иллюстрации
 (C) = только в виде специальных принадлежностей
 (D) = заводом больше не выпускается
 (1,2,...) = запасная деталь
 = Виды исполнений
- UAE** **زومرلا حرش**
 = ةروض مقرر كل ع يوتحت
 * = مري دق زارط نم تانديك ام
 (A) = ةروض مري غ
 (B) = طقف ةصاخ تامزلتسم
 (C) = ع نم ديروت ل ل ةلباق ري غ
 (D) = ه ددر م راي غ ةعطق ك سي ل
 = تازارط لا عاونا (...2,1)