

STIHL FS 75, 80, 85

(4137)

Spare Parts List

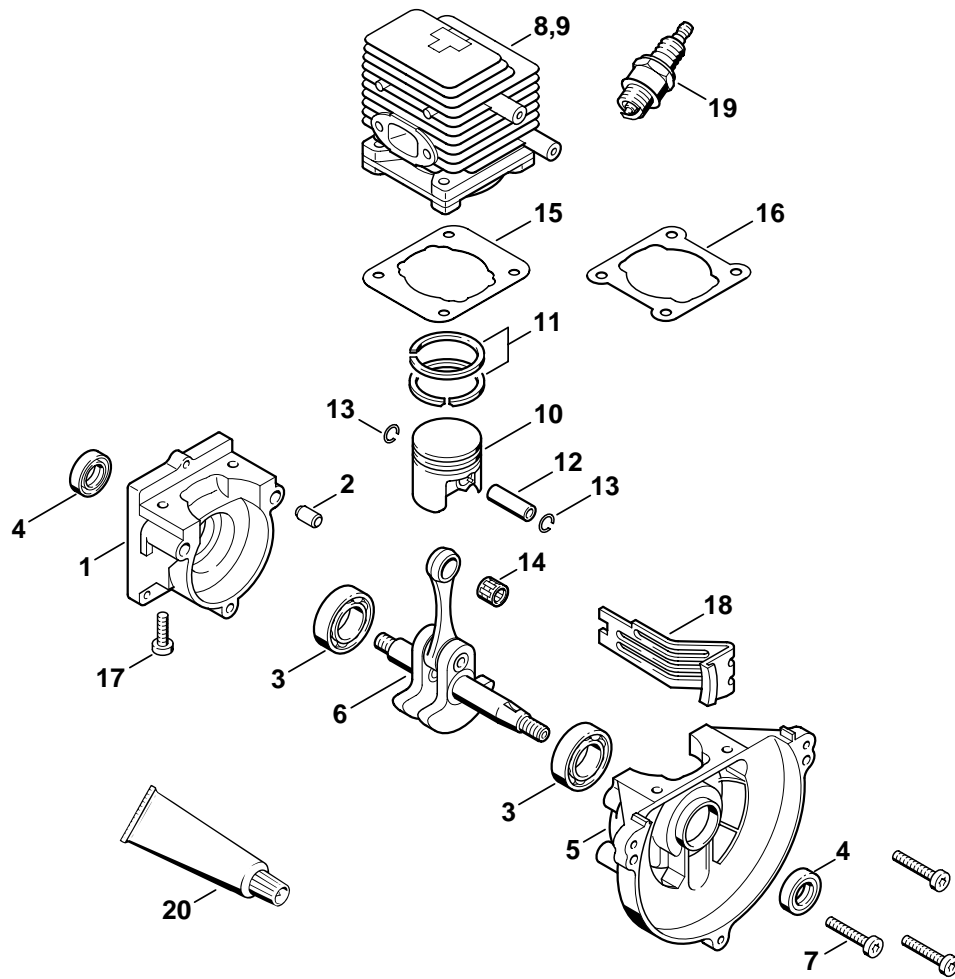

392ET065 GM

Illustration A

Kurbelgehäuse, Zylinder

Crankcase, Cylinder

Carter, Cylindre

Bild-Nr.	Teile-Nr.	St-Zahl	Benennung	Part Name	Désignation
1	4137 020 2800	1	Kurbelgehäusehälfte, Starterseite □ 2, 3	Crankcase, starter side □ 2, 3	Demi-carter de vilebrequin, côté lanceur □ 2, 3
2	0000 988 8600	2	Hülse 5x12	Sleeve 5x12	Douille 5x12
3	9503 003 0242	2	Kugellager DIN625-6201	Grooved ball bearing 6201	Roulement rainuré à billes 6201
4	9640 003 1195	2	WDR DIN3760-BS12x22x5	Oil seal 12x22x5	Bague d'étanchéité 12x22x5
5	4137 020 2600	1	Kurbelgehäusehälfte, Lüfterseite □ 3	Crankcase, fan side □ 3	Demi-carter de vilebrequin, côté ventilateur □ 3
6	4137 030 0401	1	Kurbelwelle	Crankshaft	Vilebrequin
7	9022 341 1050	3	Schraube IS-M5x25-10.9	Spline screw IS-M5x25	Vis cylindrique IS-M5x25
8	4137 020 1202	1	Zylinder mit Kolben Ø 34 mm □ 10 - 13, 17	Cylinder with piston Ø 34mm □ 10 - 13, 17	Cylindre avec piston Ø 34 mm □ 10 - 13, 17
9 *	4137 020 1201	1	(16.2001) Zylinder mit Kolben Ø 34 mm □ 10 - 13, 17	(16.2001) Cylinder with piston Ø 34 mm □ 10 - 13, 17	(16.2001) Cylindre avec piston Ø 34 mm □ 10 - 13, 17
10	4137 030 2010	1	Kolben Ø 34 mm □ 11 - 13	Piston Ø 34mm □ 11 - 13	Piston Ø 34 mm □ 11 - 13
11	4137 034 3000	2	Verdichtungsring Ø 34x1,5 mm	Piston ring Ø 34x1.5mm	Segment de piston Ø 34x1,5 mm
12	4137 034 1500	1	Kolbenbolzen	Piston pin	Axe de piston
13	9463 650 0805	2	Sprengring DIN73130-C8x0,7	Snap ring 8x0.7	Jonc d'arrêt 8x0,7
14	9512 003 1830	1	Nadelkranz 8x11x10	Needle cage 8x11x10	Cage à aiguilles 8x11x10
15	4140 029 2300	1	Zylinderdichtung	Cylinder gasket	Joint de cylindre
16 *	4137 029 2300	1	(15.2003) Zylinderdichtung	(15.2003) Cylinder gasket	(15.2003) Joint de cylindre
17	9075 478 4159	4	Schraube IS-D5x24	Pan head self-tapping screw IS-D5x24	Vis cylindrique IS-D5x24
18	4137 084 2200	1	Schutz	Guard	Pièce de protection
19	0000 400 7000	1	Zündkerze NGK BPMR7A	Spark plug NGK BPMR7A	Bougie NGK BPMR7A
19	1110 400 7005	1	Zündkerze Bosch WSR 6 F	Spark plug Bosch WSR 6 F	Bougie Bosch WSR 6 F
20	0783 830 2000	1	Dichtungsmasse Dirko HT rot (B)	Tube of sealant Dirko HT red (B)	Tube de pâte d'étanchéité Dirko HT rouge (B)

(1) FS 75, (2) FS 80, (3) FS 80 R, (4) FS 85, (5) FS 85 R, (6) FS 85 T, (7) FS 85 RX

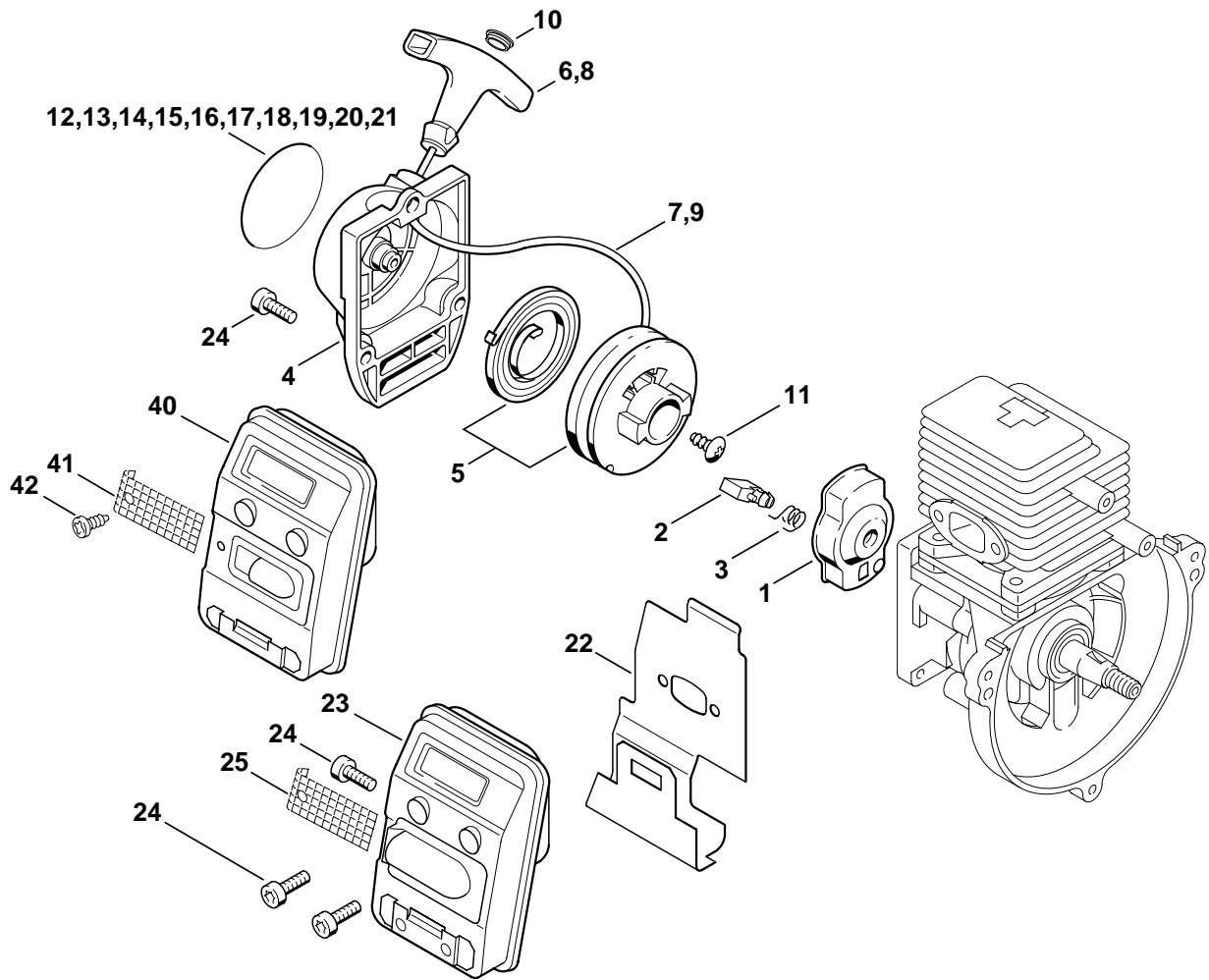

392ET073 GM

Illustration B

Anwerfvorrichtung,
Schalldämpfer

Rewind starter, Muffler

Dispositif de lancement,
Silencieux

Bild-Nr.	Teile-Nr.	St-Zahl	Benennung	Part Name	Désignation
1	4133 190 2002	1	Mitnehmer □ 2, 3	Carrier □ 2, 3	Entraîneur □ 2, 3
2	4133 195 7201	1	Klinke	Pawl	Cliquet
3	0000 998 0612	1	Schenkelfeder	Torsion spring	Ressort coudé
	4137 190 4000	1	Anwerfvorrichtung □ 4 - 7, 10, 11	Rewind starter □ 4 - 7, 10, 11	Dispositif de lancement □ 4 - 7, 10, 11
4	4137 190 0400	1	Starterdeckel	Starter cover	Couvercle de lanceur
5	4137 190 1100	1	Seilrolle mit Rückholfeder	Rope rotor with rewind spring	Poulie à câble avec ressort de rappel
6	0000 190 3403	1	Griff ElastoStart Ø 2,7 mm □ 7, 10	Starter grip ElastoStart Ø 2.7mm □ 7, 10	Poignée ElastoStart Ø 2,7 mm □ 7, 10
7	4137 195 8200	1	Anwerfseil Ø 2,7x910 mm	Starter rope Ø 2.7x910mm	Câble de lancement Ø 2,7x910 mm
	0000 930 2281	1	Anwerfseil Ø 2,7 mm x 30,8 m (A,B)	Starter rope Ø 2.7mm x 30.8m (A,B)	Câble de lancement Ø 2,7 mm x 30,8 m (A,B)
			(24.2002)	(24.2002)	(24.2002)
8 *	0000 190 3400	1	Griff ElastoStart Ø 3 mm □ 9, 10	Starter grip ElastoStart Ø 3mm □ 9, 10	Poignée ElastoStart Ø 3 mm □ 9, 10
9 *	0000 195 8200	1	Anwerfseil Ø 3x800 mm	Starter rope Ø 3x800mm	Câble de lancement Ø 3x800 mm
	* 0000 930 2208	1	Anwerfseil Ø 3 mm x 30,5 m (A,B)	Starter rope Ø 3mm x 30.5m (A,B)	Câble de lancement Ø 3 mm x 30,5 m (A,B)
10	0000 195 7000	1	Kappe	Cap	Capuchon
11	9104 003 0960	1	Schraube P5,5x12	Self-tapping screw P5.5x12	Vis Parker P5,5x12
12	4137 967 1512	1	Typenschild FS 75 (1)	Model plate FS 75 (1)	Plaque matricule FS 75 (1)
13	4137 967 1514	1	Typenschild FS 80 (2)	Model plate FS 80 (2)	Plaque matricule FS 80 (2)
14	4137 967 1533	1	Typenschild FS 80 R (3)	Model plate FS 80 R (3)	Plaque matricule FS 80 R (3)
15	4137 967 1515	1	Typenschild FS 85 (4)	Model plate FS 85 (4)	Plaque matricule FS 85 (4)
16	4137 967 1531	1	Typenschild FS 85 R (5)	Model plate FS 85 R (5)	Plaque matricule FS 85 R (5)
			(14.2002)	(14.2002)	(14.2002)
17 *	4137 967 1516	1	Typenschild FS 85 T (6)	Model plate FS 85 T (6)	Plaque matricule FS 85 T (6)
18	4137 967 1532	1	Typenschild FS 85 RX (7)	Model plate FS 85 RX (7)	Plaque matricule FS 85 RX (7)

(1) FS 75, (2) FS 80, (3) FS 80 R, (4) FS 85, (5) FS 85 R, (6) FS 85 T, (7) FS 85 RX

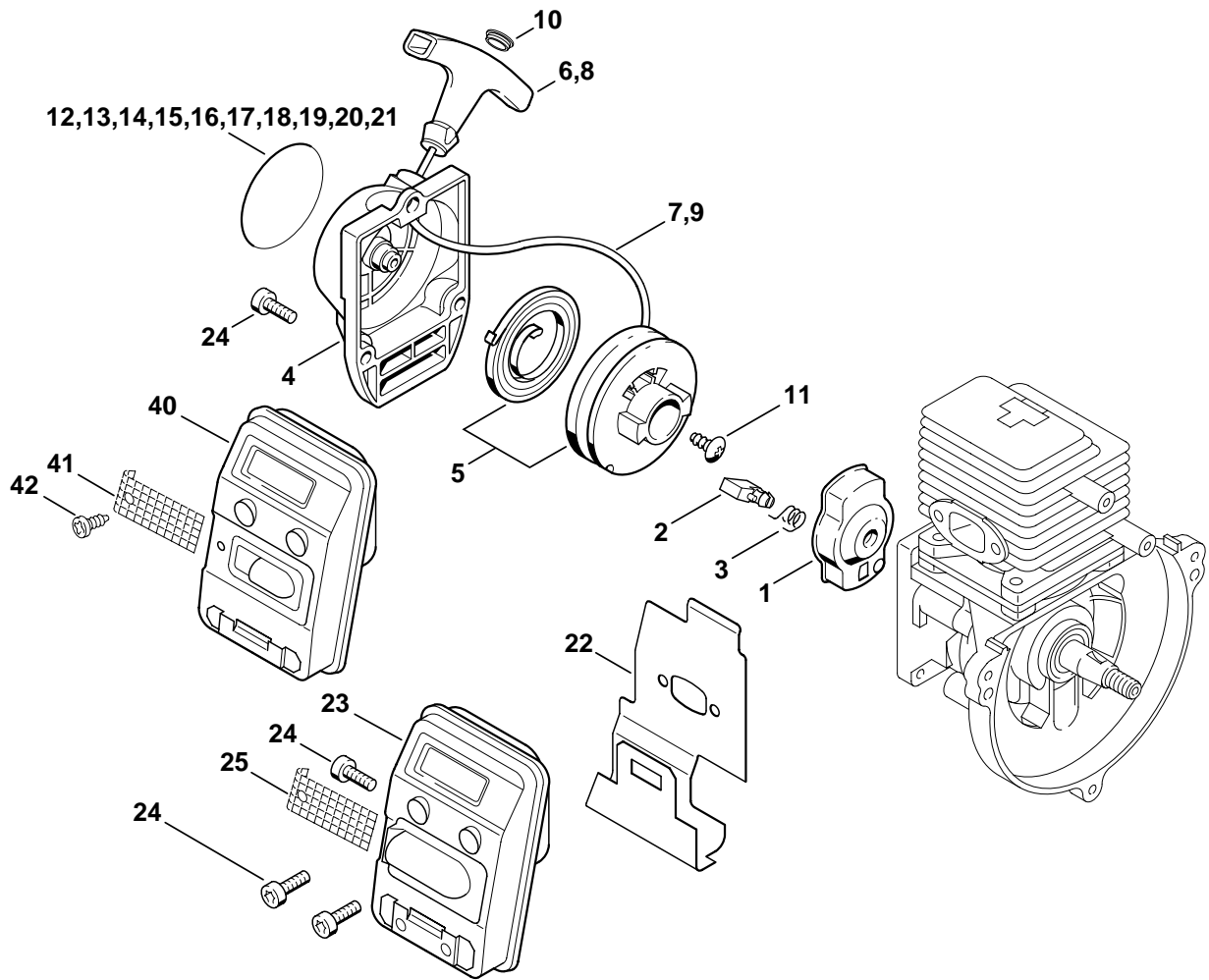

392ET073 GM

Illustration B

Anwerfvorrichtung,
Schalldämpfer

Rewind starter, Muffler

Dispositif de lancement,
Silencieux

Bild-Nr.	Teile-Nr.	St-Zahl	Benennung	Part Name	Désignation
			(16.2001)	(16.2001)	(16.2001)
19 *	0000 967 2128	1	Firmenzeichen MADE IN GERMANY	Nameplate MADE IN GERMANY	Emblème MADE IN GERMANY
20 *	0000 967 2129	1	Firmenzeichen MADE IN USA	Nameplate MADE IN USA	Emblème MADE IN USA
21 *	0000 967 2141	1	Firmenzeichen MADE IN BRAZIL	Nameplate MADE IN BRAZIL	Emblème MADE IN BRAZIL
22	4137 149 0600	1	Auspuffdichtung	Exhaust gasket	Joint d'échappement
23	4137 140 0602	1	Schalldämpfer □ 22, 25	Muffler □ 22, 25	Silencieux □ 22, 25
23	4137 140 0603	1	Schalldämpfer BR □ 22	Muffler BR □ 22	Silencieux BR □ 22
24	9022 341 0980	6	Schraube IS-M5x16-12.9	Spline screw IS-M5x16	Vis cylindrique IS-M5x16
25	4137 141 9000	1	Gitter USA, CDN, AUS	Screen USA, CDN, AUS	Grille USA, CDN, AUS
			➔ 2 38 993 299 (30.98)	➔ 2 38 993 299 (30.98)	➔ 2 38 993 299 (30.98)
40 *	4137 140 0600	1	Schalldämpfer □ 41, 42	Muffler □ 41, 42	Silencieux □ 41, 42
41 *	4137 141 9000	1	Gitter	Screen	Grille
42 *	9099 021 0810	1	Schraube DIN7971-4,2x9,5	Self-tapping screw 4.2x9.5	Vis Parker 4,2x9,5

(1) FS 75, (2) FS 80, (3) FS 80 R, (4) FS 85, (5) FS 85 R, (6) FS 85 T, (7) FS 85 RX

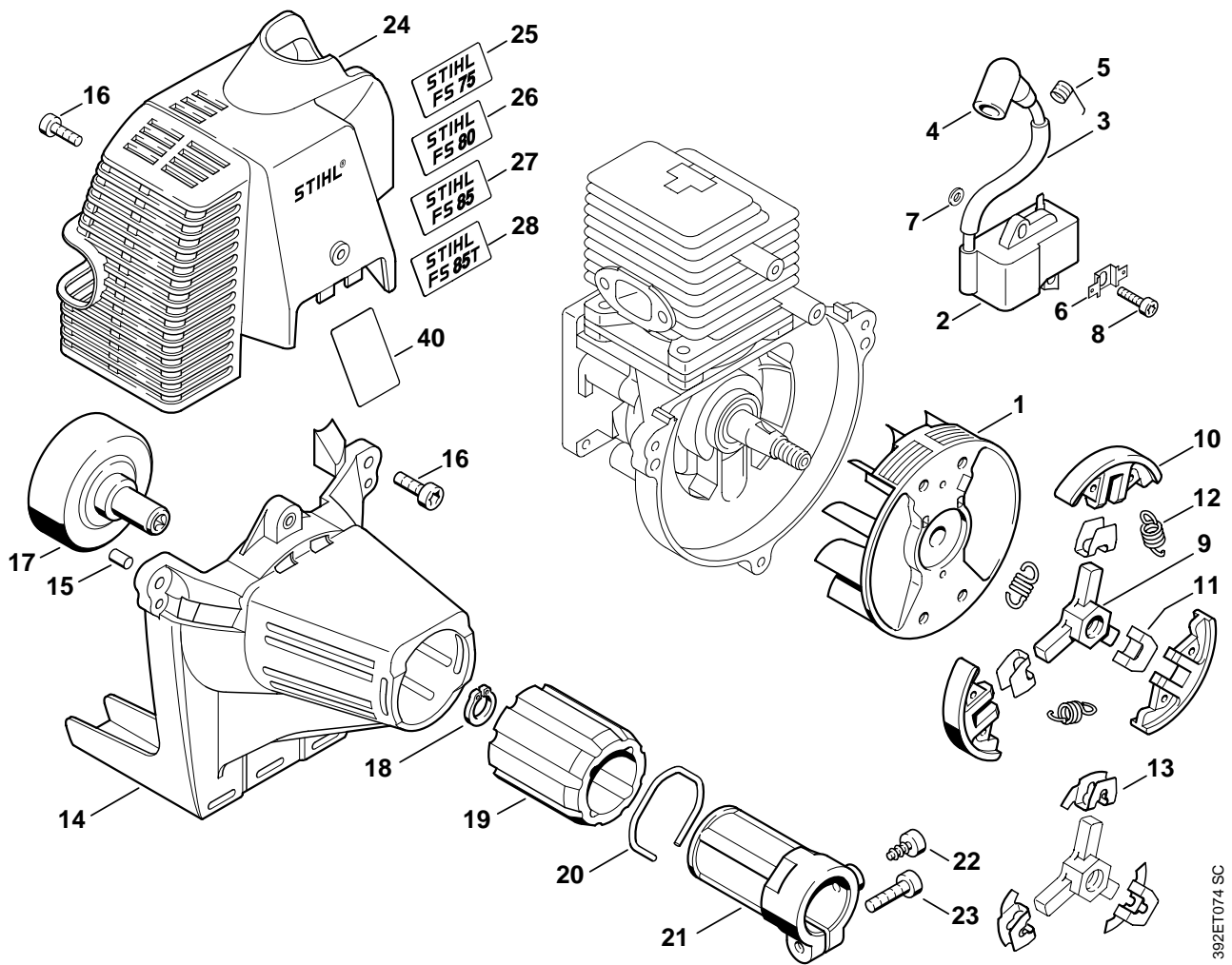

Illustration C

Zündanlage, Kupplung

Ignition system, Clutch

Dispositifs d'allumage,
Embrayage

Bild-Nr.	Teile-Nr.	St-Zahl	Benennung	Part Name	Désignation
1	4137 400 1200	1	Schwungrad	Flywheel	Rotor
2	4137 400 1350	1	Zündmodul □ 3 - 5, 7	Ignition module □ 3 - 5, 7	Module d'allumage □ 3 - 5, 7
3	4137 442 0400	1	Isolierschlauch	Insulating hose	Gaine isolante
4	1106 405 1000	1	Zündleitungsstecker	Spark plug boot	Contact de câble d'allumage
5	0000 998 0606	1	Schenkelfeder	Torsion spring	Ressort coudé
6	4137 405 1600	1	Steckverbinder	Plug connector	Connecteur enfichable
			(16.2001)	(16.2001)	(16.2001)
7 *	4137 404 9300	2	Scheibe	Washer	Rondelle
8	9022 371 0710	2	Schraube IS-M4x20-12.9	Spline screw IS-M4x20	Vis cylindrique IS-M4x20
9	4137 160 2001	1	Kupplung □ 10 - 12	Clutch □ 10 - 12	Embrayage □ 10 - 12
10	1129 162 0800	3	Fliehkgewicht	Clutch shoe	Masselotte
11	1127 162 3000	3	Halter	Retainer	Pièce de fixation
12	0000 997 5625	3	Zugfeder	Tension spring	Ressort de tension
			(42.2004)	(42.2004)	(42.2004)
13 *	1121 162 3000	3	Halter	Retainer	Pièce de fixation
14	4137 080 1800	1	Lüftergehäuse □ 15	Fan housing □ 15	Carter de ventilateur □ 15
15	9991 003 5087	3	Hülse 7,5x6,8	Sleeve 7.5x6.8	Douille 7,5x6,8
16	9022 341 0980	4	Schraube IS-M5x16-12.9	Spline screw IS-M5x16	Vis cylindrique IS-M5x16
17	4137 160 2900	1	Kupplungstrommel	Clutch drum	Cloche d'embrayage
18	9455 621 1130	1	Sicherungsring DIN471-12x1	Circlip 12x1	Circlips 12x1
19	4137 791 9300	1	Gummielement	Rubber insert	Pièce de caoutchouc
20	9457 621 4481	1	Sicherungsring	Circlip	Circlips
21	4137 790 7200	1	Hülse □ 22	Sleeve □ 22	Douille □ 22
22	9075 478 4095	1	Schraube IS-D5x12	Pan head self-tapping screw IS-D5x12	Vis cylindrique IS-D5x12
23	9022 371 1020	1	Schraube IS-M5x20-12.9	Spline screw IS-M5x20	Vis cylindrique IS-M5x20
24	4137 080 1604	1	Haube	Shroud	Capot
			(16.2001)	(16.2001)	(16.2001)
25 *	4137 967 1500	1	Typenschild FS 75 (1)	Model plate FS 75 (1)	Plaque matricule FS 75 (1)
26 *	4137 967 1502	1	Typenschild FS 80 (2)	Model plate FS 80 (2)	Plaque matricule FS 80 (2)
27 *	4137 967 1501	1	Typenschild FS 85 (4)	Model plate FS 85 (4)	Plaque matricule FS 85 (4)
28 *	4137 967 1510	1	Typenschild FS 85 T (6)	Model plate FS 85 T (6)	Plaque matricule FS 85 T (6)
			➔ 2 38 993 299 (30.98)	➔ 2 38 993 299 (30.98)	➔ 2 38 993 299 (30.98)
40 *	4137 084 8300	1	Abstrahlfolie	Reflector foil	Feuille calorifuge

(1) FS 75, (2) FS 80, (3) FS 80 R, (4) FS 85, (5) FS 85 R, (6) FS 85 T, (7) FS 85 RX

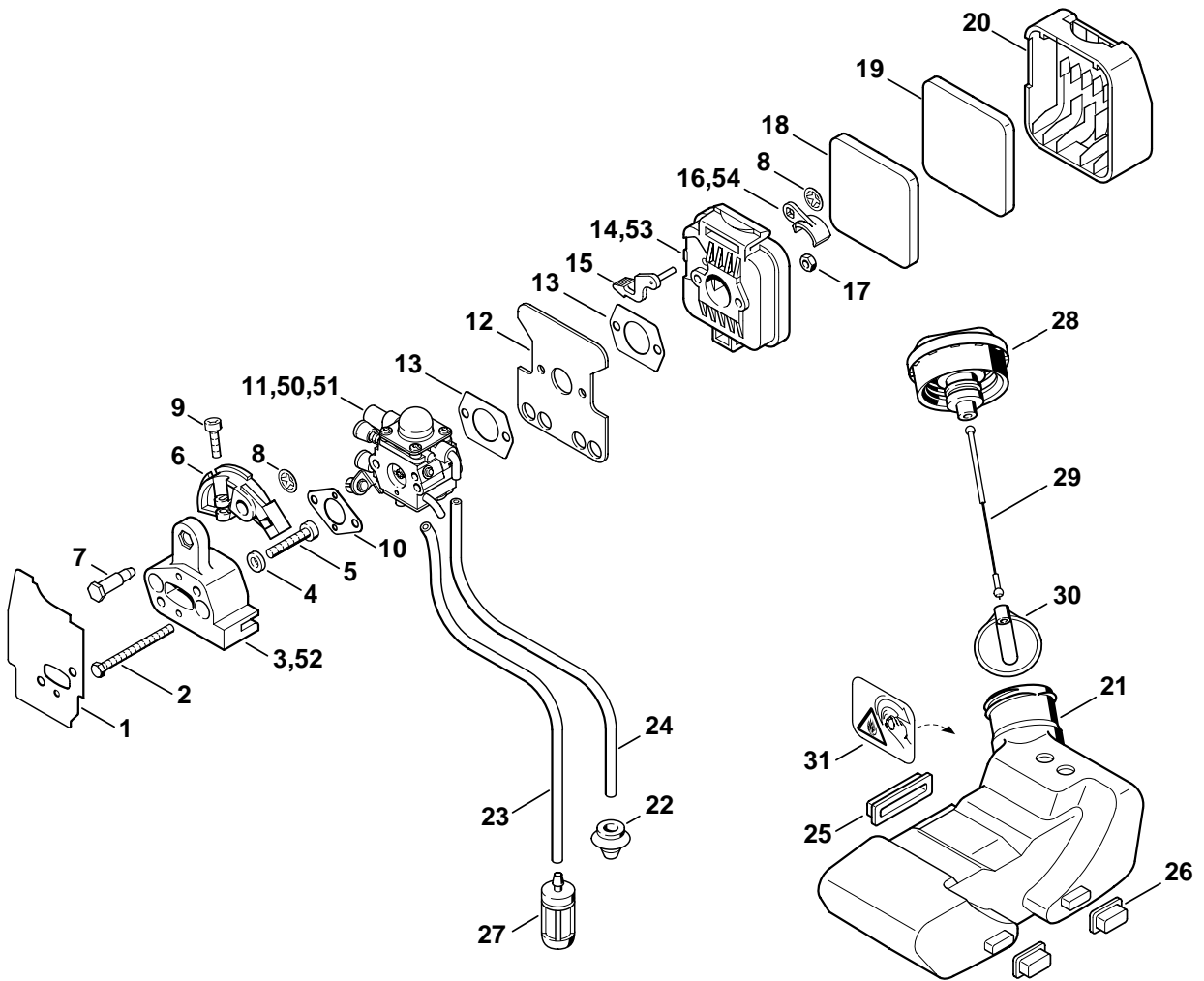

392ET072 SC

Illustration D

Luftfilter, Kraftstofftank

Air filter, Fuel tank

Filtre à air, Réservoir
d'essence

Bild-Nr.	Teile-Nr.	St-Zahl	Benennung	Part Name	Désignation
1	4137 129 0905	1	Dichtung	Gasket	Joint
2	9007 319 1130	2	Schraube DIN931-M5x62-8.8	Hexagon head screw M5x62	Vis à six pans M5x62
3	4137 121 1601	1	Zwischenflansch	Spacer flange	Bride intermédiaire
4	9291 021 0121	2	Scheibe DIN125-A5,3	Washer 5.3	Rondelle 5,3
5	9022 341 1050	2	Schraube IS-M5x25-10.9	Spline screw IS-M5x25	Vis cylindrique IS-M5x25
6	4137 182 7600	1	Spannstück	Tensioner	Pièce de serrage
7	4137 123 8900	1	Bolzen	Pin	Boulon
8	9417 003 7512	2	Federmutter 4x9,6x1,8	Push nut 4.0x9.6x1.8	Clip-écrou 4,0x9,6x1,8
9	9022 313 0680	1	Schraube IS-M4x16-8.8	Spline screw IS-M4x16	Vis cylindrique IS-M4x16
10	4137 129 0900	1	Dichtung	Gasket	Joint
11	4137 120 0608	1	Vergaser C1Q-S69A	Carburetor C1Q-S69A	Carburateur C1Q-S69A
11	4137 120 0611	1	Vergaser C1Q-S80 BR	Carburetor C1Q-S80 BR	Carburateur C1Q-S80 BR
			(15.2003)	(15.2003)	(15.2003)
11 *	4137 120 0606	1	Vergaser C1Q-S63A	Carburetor C1Q-S63A	Carburateur C1Q-S63A
11 *	4137 120 0609	1	Vergaser C1Q-S78 BR	Carburetor C1Q-S78 BR	Carburateur C1Q-S78 BR
			(16.2001)	(16.2001)	(16.2001)
11 *	4137 120 0604	1	Vergaser C1Q-S56	Carburetor C1Q-S56	Carburateur C1Q-S56
11 *	4137 120 0603	1	Vergaser C1Q-S45	Carburetor C1Q-S45	Carburateur C1Q-S45
			(17.2002)	(17.2002)	(17.2002)
11 *	4137 120 0607	1	Vergaser C1Q-S60 BR	Carburetor C1Q-S60 BR	Carburateur C1Q-S60 BR
12	4227 122 1805	1	Abstrahlblech	Heat shield	Tôle calorifuge
13	4114 149 1205	2	Dichtung	Gasket	Joint
14	4137 140 2801	1	Filtergehäuse □ 8, 15, 16	Filter housing □ 8, 15, 16	Boîtier de filtre □ 8, 15, 16
15	4137 141 3700	1	Hebel	Lever	Levier
16	4137 141 3801	1	Chokeklappe	Choke shutter	Volet de démarrage

(1) FS 75, (2) FS 80, (3) FS 80 R, (4) FS 85, (5) FS 85 R, (6) FS 85 T, (7) FS 85 RX

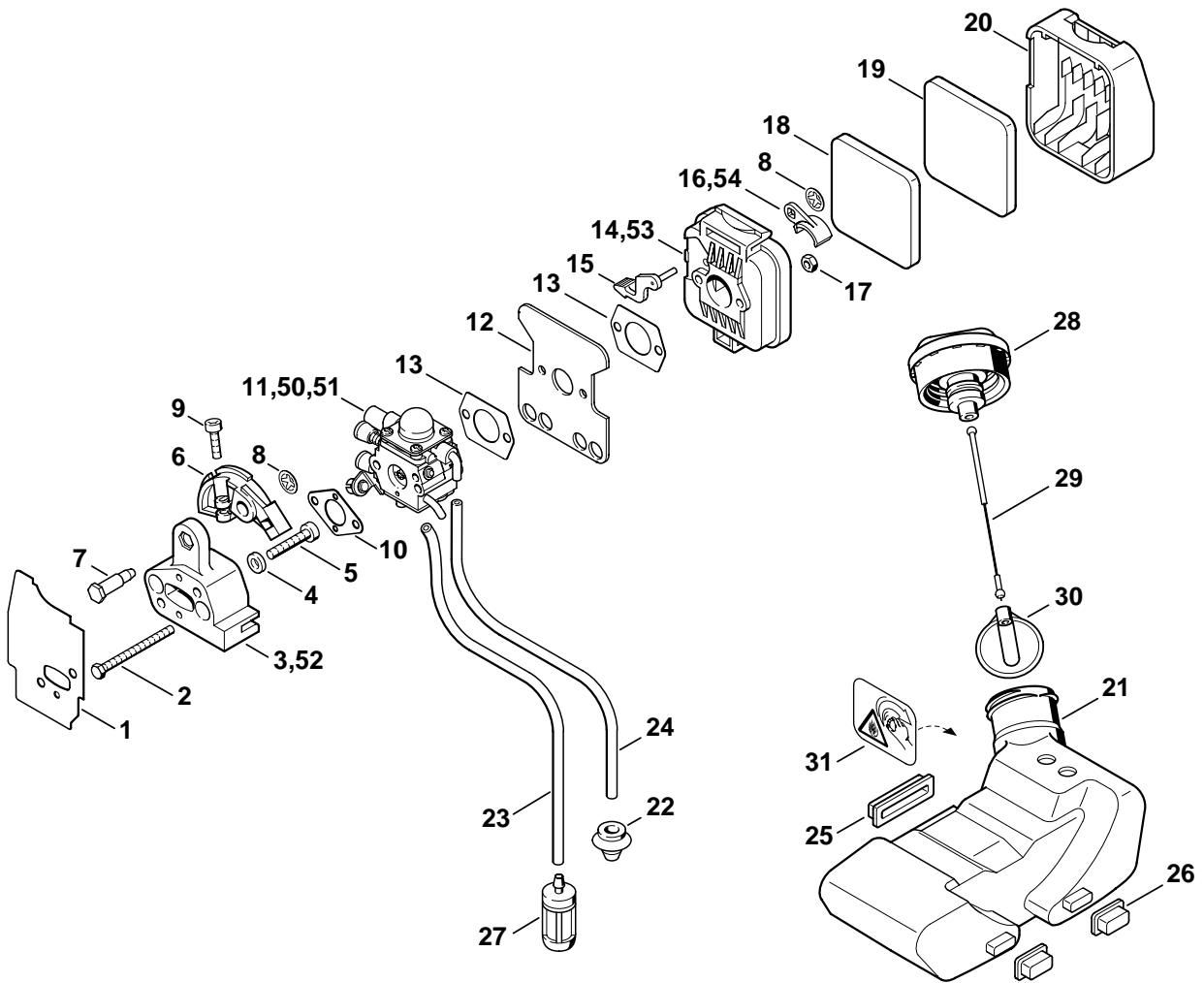

392ET072 SC

Illustration D

Luftfilter, Kraftstofftank

Air filter, Fuel tank

Filtre à air, Réservoir
d'essence

Bild-Nr.	Teile-Nr.	St-Zahl	Benennung	Part Name	Désignation
17	9210 261 0700	2	Mutter DIN934-M5-10	Hexagon nut M5	Ecrou à six pans M5
18	4137 124 2800	1	Filter	Filter	Filtre
19	4137 124 1500	1	Vorfilter	Prefilter	Préfiltre
20	4137 141 0500	1	Filterdeckel	Filter cover	Couvercle de filtre
21	4137 350 0400	1	Kraftstofftank □ 22 - 24	Fuel tank □ 22 - 24	Réservoir d'essence □ 22 - 24
22	0000 989 0516	2	Tülle	Grommet	Douille
23		1	Schlauch 3,1x5,7x180 mm (D)	Hose 3.1x5.7x180 mm (D)	Tuyau 3,1x5,7x180 mm (D)
24		1	Schlauch 3,1x5,7x135 mm (D)	Hose 3.1x5.7x135 mm (D)	Tuyau 3,1x5,7x135 mm (D)
	0000 930 2803	1	Schlauch 3,1x5,7 mm x 1 m (A,B)	Hose 3.1x5.7 mm x 1 m (A,B)	Tuyau 3,1x5,7 mm x 1 m (A,B)
25	4137 352 8100	1	Einlage	Insert	Pièce intercalaire
26	4137 352 8105	2	Einlage	Insert	Pièce intercalaire
27	0000 350 3502	1	Saugkopf	Pickup body	Crépine d'aspiration
28	4128 350 0505	1	Tankverschluss □ 29, 30	Filler cap □ 29, 30	Bouchon du réservoir □ 29, 30
29	0000 350 0900	1	Seil	Rope	Corde
30	0000 353 0800	1	Verliersicherung	Filler cap retainer	Pièce de sûreté
31	0000 967 3693	1	Warnhinweis Piktogramm Tankdeckel USA, CDN	Warning pictogram Filler cap USA, CDN	Pictogramme d'avertissement Bouchon de réservoir USA, CDN
50 *	4137 120 0601	1	Vergaser WT-447 (C)	Carburetor WT-447 (C)	Carburateur WT-447 (C)
			➔ 1 42 812 153 (21.1999)	➔ 1 42 812 153 (21.1999)	➔ 1 42 812 153 (21.1999)
51 *	4137 120 0600	1	Vergaser C1Q-S28D	Carburetor C1Q-S28D	Carburateur C1Q-S28D
52 *	4137 121 1600	1	Zwischenflansch	Spacer flange	Bride intermédiaire
53 *	4137 140 2800	1	Filtergehäuse □ 8, 15, 54	Filter housing □ 8, 15, 54	Boîtier de filtre □ 8, 15, 54
54 *	4137 141 3800	1	Chokeklappe	Choke shutter	Volet de démarrage

(1) FS 75, (2) FS 80, (3) FS 80 R, (4) FS 85, (5) FS 85 R, (6) FS 85 T, (7) FS 85 RX

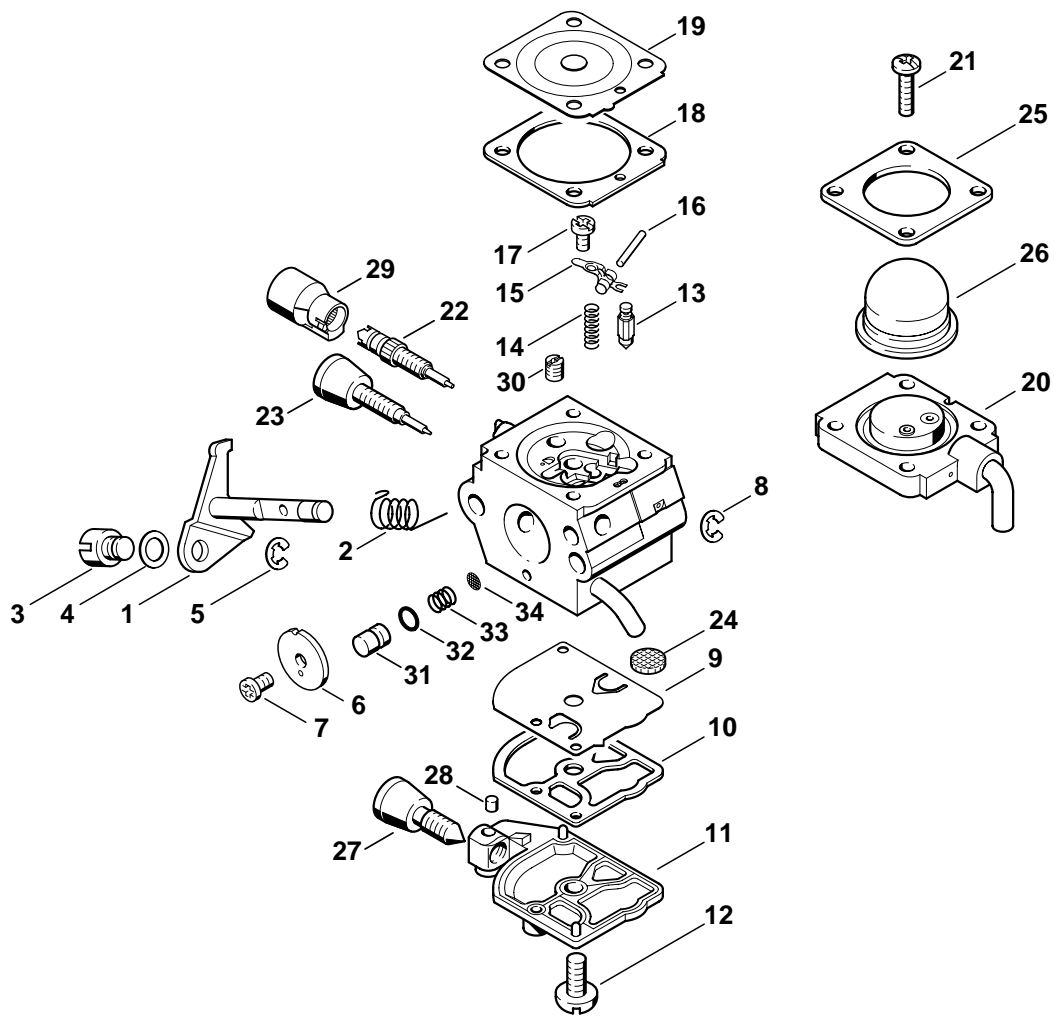

392ET064 SC

Illustration E

Vergaser C1Q-S69A

Carburetor C1Q-S69A

Carburateur C1Q-S69A

Bild-Nr.	Teile-Nr.	St-Zahl	Benennung	Part Name	Désignation
	4137 120 0608	1	Vergaser C1Q-S69A □ 1 - 34	Carburetor C1Q-S69A □ 1 - 34	Carburateur C1Q-S69A □ 1 - 34
1	4137 120 7100	1	Drosselwelle mit Hebel	Throttle shaft with lever	Axe de papillon avec levier
2	1123 122 3000	1	Feder	Spring	Ressort
3	4128 121 8900	1	Bolzen	Pin	Boulon
4	4137 121 8600	1	Scheibe	Washer	Rondelle
5	1120 122 9000	1	Sicherungsring	E-clip	Circlip
6	4229 121 3303	1	Drosselklappe	Throttle shutter	Papillon
7	1125 122 7403	1	Halbrundschraube	Round head screw	Vis à tête ronde
8	1125 122 9001	1	Sicherungsscheibe	E-clip	Circlips
9	1129 121 4800	1	Pumpenmembrane	Pump diaphragm	Membrane de pompe
10	1123 129 0905	1	Dichtung	Gasket	Joint
11	1123 121 0800	1	Abschlussdeckel	End cover	Couvercle
12	1120 122 7800	1	Linsensenschraube	Oval head screw	Vis à tête bombée fraisée
13	4116 121 5100	1	Einlassnadel	Inlet needle	Pointeau d'admission
14	1120 122 3004	1	Feder	Spring	Ressort
15	1125 121 5000	1	Einlassregelhebel	Inlet control lever	Levier de réglage d'admission
16	1120 121 9200	1	Achse	Spindle	Axe
17	1120 122 6600	1	Bundschaube	Collar screw	Vis à embase
18	4229 129 0901	1	Dichtung	Gasket	Joint
19	4229 121 4700	1	Regelmembrane	Metering diaphragm	Membrane de réglage
20	4228 120 2200	1	Flansch	Flange	Bride
21	4226 122 7100	4	Schraube	Screw	Vis
22	4229 122 6701	1	Hauptstellschraube	High speed adjustment screw	Vis H de richesse à haut régime
23	4229 122 6800	1	Leerlaufstellschraube	Low speed adjustment screw	Vis L de richesse au ralenti
24	1123 121 7800	1	Sieb	Strainer	Tamis
25	4140 121 0800	1	Abschlussdeckel	End cover	Couvercle
26	4226 121 2700	1	Kappe	Cap	Capuchon
27	4180 122 6200	1	Leerlaufanschlagschraube	Idle speed adjustment screw	Vis de réglage de régime de ralenti
28	1125 122 4200	1	Kugel	Ball	Bille
29	4229 121 2701	1	Kappe	Cap	Capuchon
30	4229 121 5602	1	Festdüse 0.35	Fixed jet 0.35	Gicleur fixe 0.35
31	4229 121 5800	1	Pumpenkolben	Pump piston	Piston de pompe
32	4140 122 3600	1	Dichtring	Sealing ring	Anneau de joint
33	4229 122 3001	1	Feder	Spring	Ressort
34	1120 121 7801	1	Sieb	Strainer	Tamis
	4140 007 1060	1	Satz Vergaserteile □ 9, 10, 18 - 20	Set of carburetor parts □ 9, 10, 18 - 20	Jeu de pièces de carburateur □ 9, 10, 18 - 20

(1) FS 75, (2) FS 80, (3) FS 80 R, (4) FS 85, (5) FS 85 R, (6) FS 85 T, (7) FS 85 RX

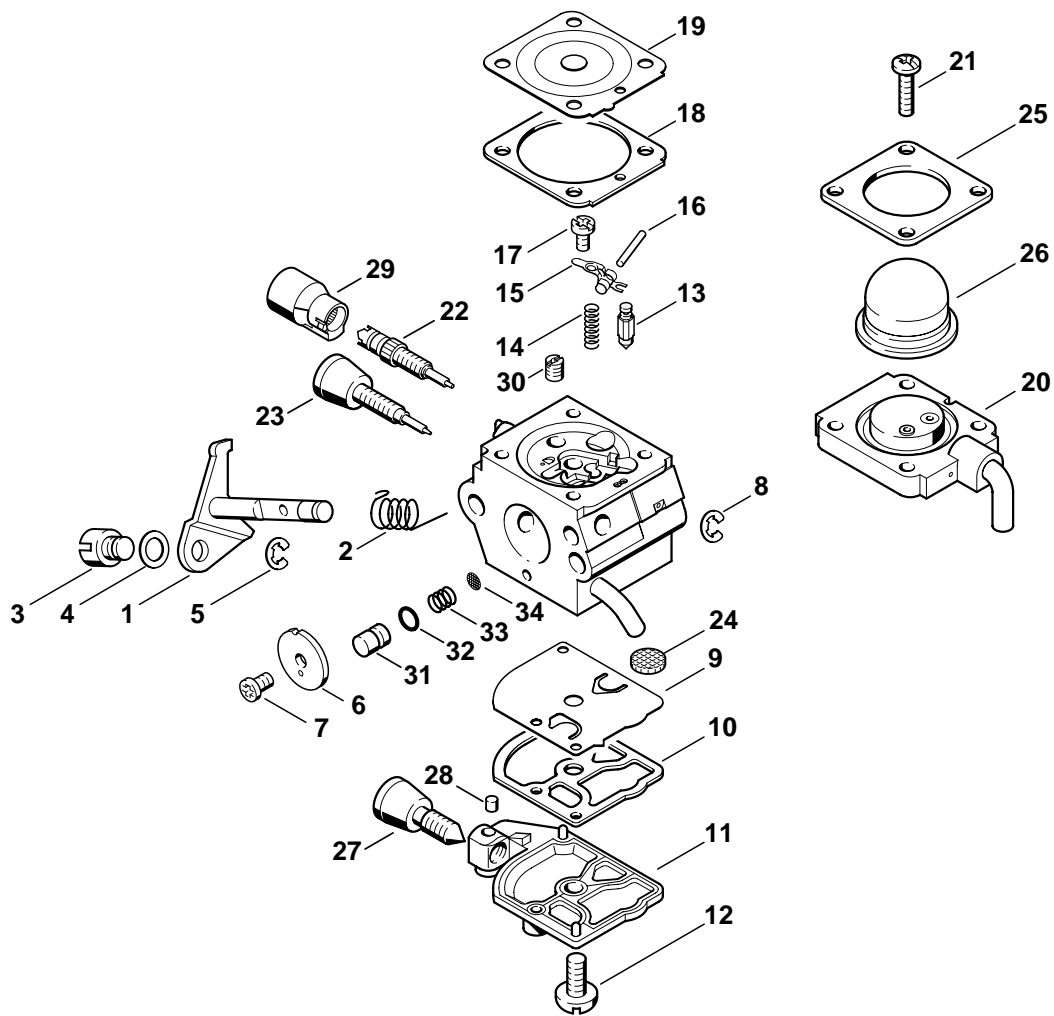

392ET064 SC

Illustration F

Vergaser C1Q-S80 BR

Carburetor C1Q-S80 BR

Carburateur C1Q-S80 BR

Bild-Nr.	Teile-Nr.	St-Zahl	Benennung	Part Name	Désignation
	4137 120 0611	1	Vergaser C1Q-S80 □ 1 - 34	Carburetor C1Q-S80 □ 1 - 34	Carburateur C1Q-S80 □ 1 - 34
1	4137 120 7100	1	Drosselwelle mit Hebel	Throttle shaft with lever	Axe de papillon avec levier
2	1123 122 3000	1	Feder	Spring	Ressort
3	4128 121 8900	1	Bolzen	Pin	Boulon
4	4137 121 8600	1	Scheibe	Washer	Rondelle
5	1120 122 9000	1	Sicherungsring	E-clip	Circlip
6	4229 121 3303	1	Drosselklappe	Throttle shutter	Papillon
7	1125 122 7403	1	Halbrundschraube	Round head screw	Vis à tête ronde
8	1125 122 9001	1	Sicherungsscheibe	E-clip	Circlips
9	1129 121 4800	1	Pumpenmembrane	Pump diaphragm	Membrane de pompe
10	1123 129 0905	1	Dichtung	Gasket	Joint
11	1123 121 0800	1	Abschlussdeckel	End cover	Couvercle
12	1120 122 7800	1	Linsensenschraube	Oval head screw	Vis à tête bombée fraisée
13	4116 121 5100	1	Einlassnadel	Inlet needle	Pointeau d'admission
14	1120 122 3004	1	Feder	Spring	Ressort
15	1125 121 5000	1	Einlassregelhebel	Inlet control lever	Levier de réglage d'admission
16	1120 121 9200	1	Achse	Spindle	Axe
17	1120 122 6600	1	Bundschaube	Collar screw	Vis à embase
18	4229 129 0901	1	Dichtung	Gasket	Joint
19	4229 121 4700	1	Regelmembrane	Metering diaphragm	Membrane de réglage
20	4228 120 2200	1	Flansch	Flange	Bride
21	4226 122 7100	4	Schraube	Screw	Vis
22	4229 122 6701	1	Hauptstellschraube	High speed adjustment screw	Vis H de richesse à haut régime
23	4229 122 6800	1	Leerlaufstellschraube	Low speed adjustment screw	Vis L de richesse au ralenti
24	1123 121 7800	1	Sieb	Strainer	Tamis
25	4140 121 0800	1	Abschlussdeckel	End cover	Couvercle
26	4226 121 2700	1	Kappe	Cap	Capuchon
27	4180 122 6200	1	Leerlaufanschlagschraube	Idle speed adjustment screw	Vis de réglage de régime de ralenti
28	1125 122 4200	1	Kugel	Ball	Bille
29	4229 121 2701	1	Kappe	Cap	Capuchon
30	4229 121 5603	1	Festdüse 0.37	Fixed jet 0.37	Gicleur fixe 0.37
31	4229 121 5800	1	Pumpenkolben	Pump piston	Piston de pompe
32	4140 122 3600	1	Dichtring	Sealing ring	Anneau de joint
33	4229 122 3001	1	Feder	Spring	Ressort
34	1120 121 7801	1	Sieb	Strainer	Tamis
	4140 007 1060	1	Satz Vergaserteile □ 9, 10, 18 - 20	Set of carburetor parts □ 9, 10, 18 - 20	Jeu de pièces de carburateur □ 9, 10, 18 - 20

(1) FS 75, (2) FS 80, (3) FS 80 R, (4) FS 85, (5) FS 85 R, (6) FS 85 T, (7) FS 85 RX

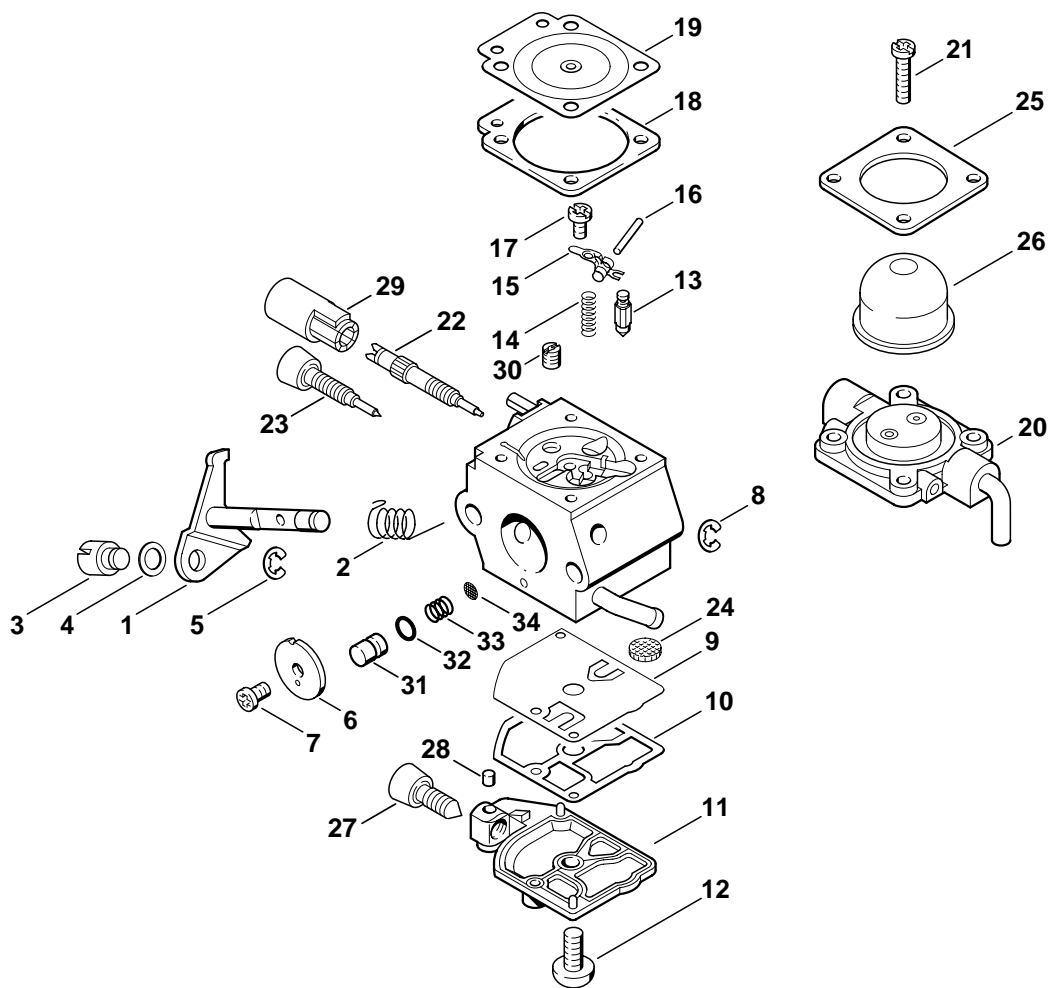

392ET046 GM

Illustration G

Vergaser C1Q-S63A,
C1Q-S78 BRCarburetor C1Q-S63A,
C1Q-S78 BRCarburateur C1Q-S63A,
C1Q-S78 BR

Bild-Nr.	Teile-Nr.	St-Zahl	Benennung	Part Name	Désignation
			(15.2003)	(15.2003)	(15.2003)
	* 4137 120 0606	1	Vergaser C1Q-S63A □ 1 - 34	Carburetor C1Q-S63A □ 1 - 34	Carburateur C1Q-S63A □ 1 - 34
	* 4137 120 0609	1	Vergaser C1Q-S78 BR □ 1 - 34	Carburetor C1Q-S78 BR □ 1 - 34	Carburateur C1Q-S78 BR □ 1 - 34
1	* 4137 120 7100	1	Drosselwelle mit Hebel	Throttle shaft with lever	Axe de papillon avec levier
2	* 1123 122 3000	1	Feder	Spring	Ressort
3	* 4128 121 8900	1	Bolzen	Pin	Boulon
4	* 4137 121 8600	1	Scheibe	Washer	Rondelle
5	* 1120 122 9000	1	Sicherungsring	E-clip	Circlip
6	* 4229 121 3303	1	Drosselklappe	Throttle shutter	Papillon
7	* 1125 122 7403	1	Halbrundschraube	Round head screw	Vis à tête ronde
8	* 1125 122 9001	1	Sicherungsscheibe	E-clip	Circlips
9	* 1129 121 4800	1	Pumpenmembrane	Pump diaphragm	Membrane de pompe
10	* 1123 129 0905	1	Dichtung	Gasket	Joint
11	* 1123 121 0800	1	Abschlussdeckel	End cover	Couvercle
12	* 1120 122 7800	1	Linsensenkschraube	Oval head screw	Vis à tête bombée fraisée
13	* 4116 121 5100	1	Einlassnadel	Inlet needle	Pointeau d'admission
14	* 1120 122 3004	1	Feder	Spring	Ressort
15	* 1125 121 5000	1	Einlassregelhebel	Inlet control lever	Levier de réglage d'admission
16	* 1120 121 9200	1	Achse	Spindle	Axe
17	* 1120 122 6600	1	Bundschrabe	Collar screw	Vis à embase
18	* 1129 129 0900	1	Dichtung	Gasket	Joint
19	* 4129 121 4700	1	Regelmembrane	Metering diaphragm	Membrane de réglage
20	* 4140 120 2200	1	Flansch	Flange	Bride
21	* 4226 122 7100	4	Schraube	Screw	Vis
22	* 4229 122 6700	1	Hauptstellschraube	High speed adjustment screw	Vis H de richesse à haut régime
23	* 4229 122 6800	1	Leerlaufstellschraube	Low speed adjustment screw	Vis L de richesse au ralenti
24	* 1123 121 7800	1	Sieb	Strainer	Tamis
25	* 4140 121 0800	1	Abschlussdeckel	End cover	Couvercle
26	* 4226 121 2700	1	Kappe	Cap	Capuchon
27	* 4229 122 6200	1	Leerlaufanschlagschraube	Idle speed adjustment screw	Vis de réglage de régime de ralenti
28	* 1125 122 4200	1	Kugel	Ball	Bille
29	* 4229 121 2700	1	Kappe	Cap	Capuchon
30	* 4137 121 5603	1	Festdüse 0.34	Fixed jet 0.34	Gicleur fixe 0.34
31	* 4229 121 5800	1	Pumpenkolben	Pump piston	Piston de pompe
32	* 4140 122 3600	1	Dichtring	Sealing ring	Anneau de joint
33	* 4229 122 3001	1	Feder	Spring	Ressort
34	* 1120 121 7801	1	Sieb	Strainer	Tamis
	* 1129 007 1062	1	Satz Vergaserteile □ 9, 10, 18, 19	Set of carburetor parts □ 9, 10, 18, 19	Jeu de pièces de carburateur □ 9, 10, 18, 19

(1) FS 75, (2) FS 80, (3) FS 80 R, (4) FS 85, (5) FS 85 R, (6) FS 85 T, (7) FS 85 RX

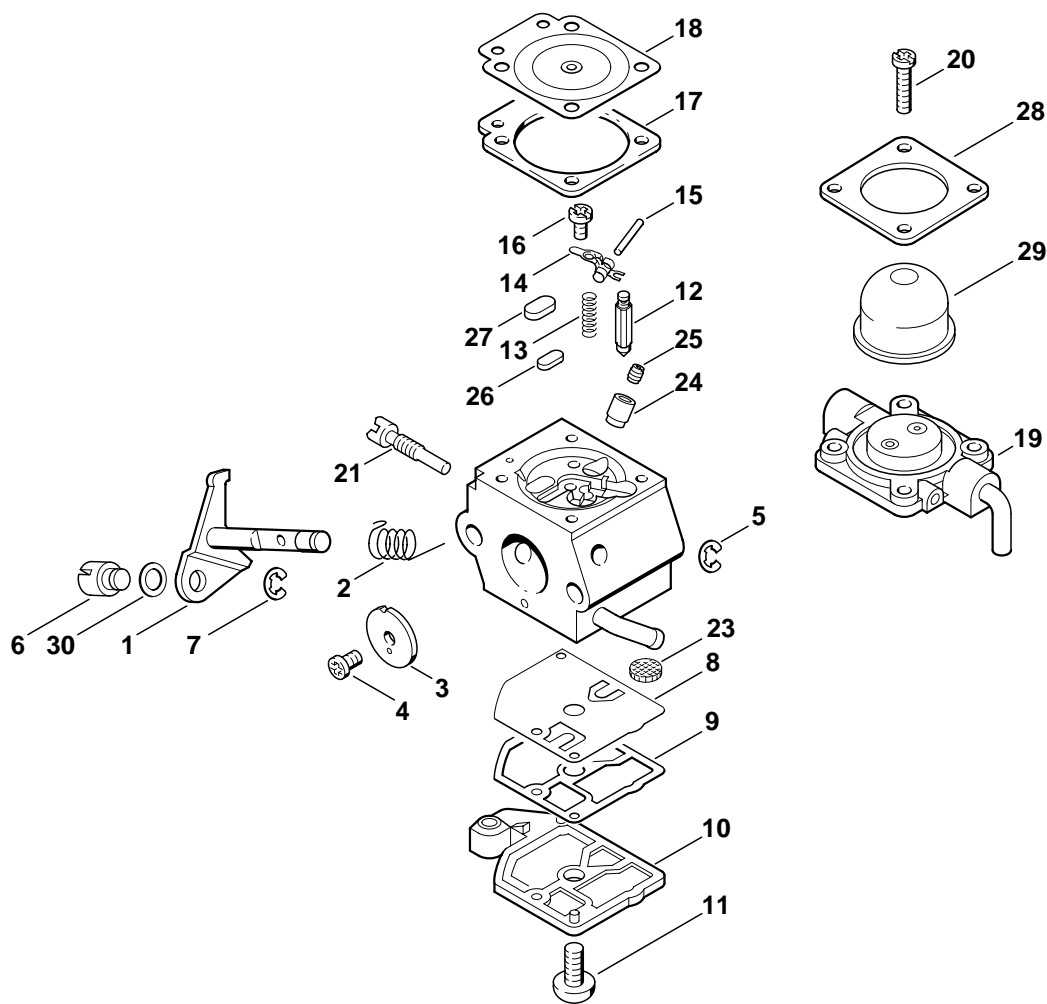

392ET039 GM

Bild-Nr.	Teile-Nr.	St-Zahl	Benennung	Part Name	Désignation
			(16.2001)	(16.2001)	(16.2001)
	* 4137 120 0604	1	Vergaser C1Q-S56 □ 1 - 30	Carburetor C1Q-S56 □ 1 - 30	Carburateur C1Q-S56 □ 1 - 30
1 *	4226 120 7100	1	Drosselwelle mit Hebel	Throttle shaft with lever	Axe de papillon avec levier
2 *	1123 122 3000	1	Feder	Spring	Ressort
3 *	4137 121 3300	1	Drosselklappe	Throttle shutter	Papillon
4 *	1125 122 7403	1	Halbrundschraube	Round head screw	Vis à tête ronde
5 *	1125 122 9001	1	Sicherungsscheibe	E-clip	Circlips
6 *	4137 121 8900	1	Bolzen	Pin	Boulon
7 *	1120 122 9000	1	Sicherungsring	E-clip	Circlip
8 *	1129 121 4800	1	Pumpenmembrane	Pump diaphragm	Membrane de pompe
9 *	1123 129 0905	1	Dichtung	Gasket	Joint
10 *	4128 121 0800	1	Abschlussdeckel	End cover	Couvercle
11 *	1120 122 7800	1	Linsensenschraube	Oval head screw	Vis à tête bombée fraisée
12 *	4116 121 5100	1	Einlassnadel	Inlet needle	Pointeau d'admission
13 *	1123 122 3001	1	Feder	Spring	Ressort
14 *	1125 121 5000	1	Einlassregelhebel	Inlet control lever	Levier de réglage d'admission
15 *	1120 121 9200	1	Achse	Spindle	Axe
16 *	1120 122 6600	1	Bundschraube	Collar screw	Vis à embase
17 *	4129 129 0902	1	Dichtung	Gasket	Joint
18 *	4129 121 4700	1	Regelmembrane	Metering diaphragm	Membrane de réglage
19 *	4140 120 2250	1	Flansch □ 17 - 20, 28	Flange □ 17 - 20, 28	Bride □ 17 - 20, 28
20 *	4226 122 7100	4	Schraube	Screw	Vis
21 *	4137 122 6300	1	Leerlaufdrehzahlschraube	Idle speed adjustment screw	Vis de réglage de régime de ralenti
23 *	1123 121 7800	1	Sieb	Strainer	Tamis
24 *	4137 122 5100	1	Austrittsventil	Outlet valve	Soupape de sortie
25 *	4137 121 5601	1	Festdüse 0.42	Fixed jet 0.42	Gicleur fixe 0.42
26 *	4119 121 0700	1	Verschlussplatte	Cup plug	Plaque de fermeture
27 *	4129 121 0700	1	Verschlussplatte	Cup plug	Plaque de fermeture
28 *		1	Abschlussdeckel (D)	End cover (D)	Couvercle (D)
29 *	4226 121 2700	1	Kappe	Cap	Capuchon
30 *	4137 121 8600	1	Scheibe	Washer	Rondelle
	* 4227 007 1060	1	Satz Vergaserteile □ 8, 9, 17, 18	Set of carburetor parts □ 8, 9, 17, 18	Jeu de pièces de carburateur □ 8, 9, 17, 18

(1) FS 75, (2) FS 80, (3) FS 80 R, (4) FS 85, (5) FS 85 R, (6) FS 85 T, (7) FS 85 RX

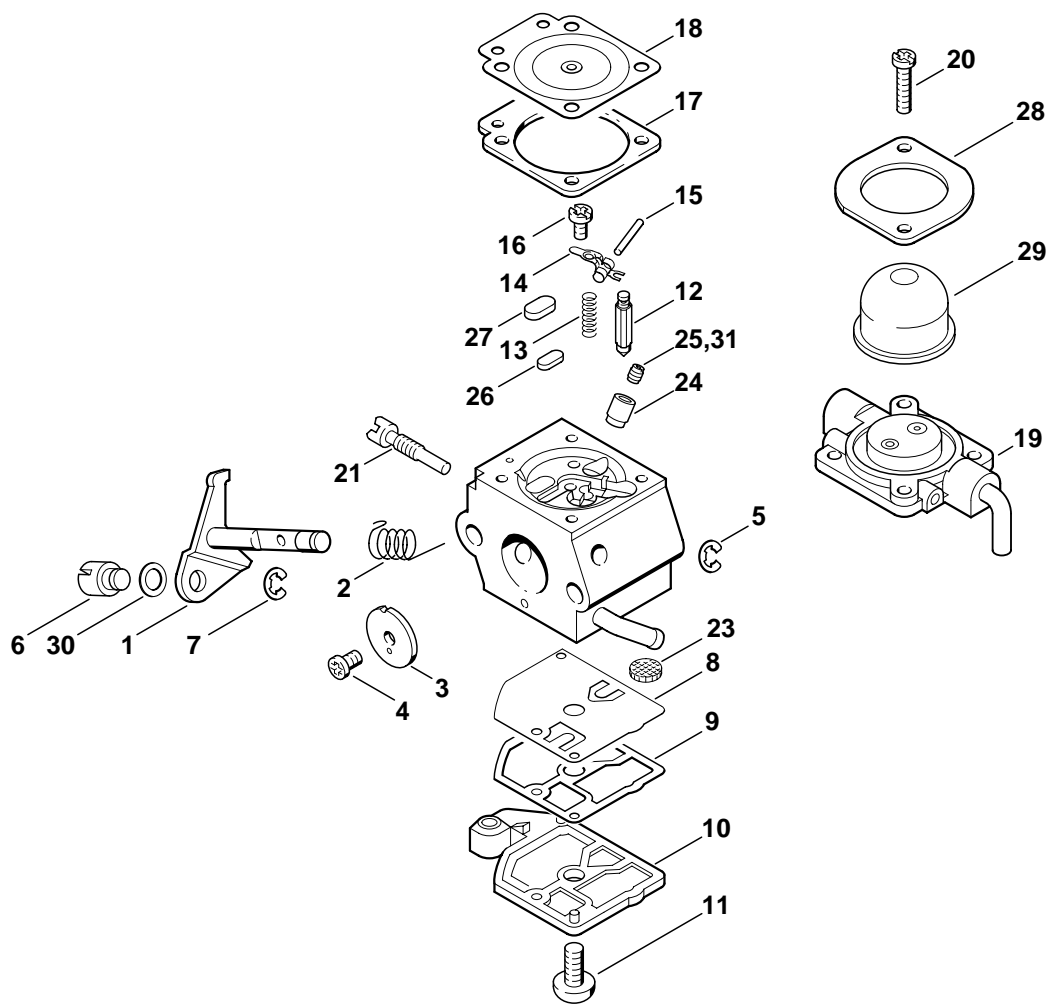

392ET050 GM

Illustration J

Vergaser C1Q-S60 BR

Carburetor C1Q-S60 BR

Carburateur C1Q-S60 BR

Bild-Nr.	Teile-Nr.	St-Zahl	Benennung	Part Name	Désignation
			(17.2002)	(17.2002)	(17.2002)
	* 4137 120 0607	1	Vergaser C1Q-S60 □ 1 - 30	Carburetor C1Q-S60 □ 1 - 30	Carburateur C1Q-S60 □ 1 - 30
1 *	4226 120 7100	1	Drosselwelle mit Hebel	Throttle shaft with lever	Axe de papillon avec levier
2 *	1123 122 3000	1	Feder	Spring	Ressort
3 *	4137 121 3300	1	Drosselklappe	Throttle shutter	Papillon
4 *	1125 122 7403	1	Halbrundschraube	Round head screw	Vis à tête ronde
5 *	1125 122 9001	1	Sicherungsscheibe	E-clip	Circlips
6 *	4128 121 8900	1	Bolzen	Pin	Boulon
7 *	1120 122 9000	1	Sicherungsring	E-clip	Circlip
8 *	1129 121 4800	1	Pumpenmembrane	Pump diaphragm	Membrane de pompe
9 *	1123 129 0905	1	Dichtung	Gasket	Joint
10 *	4128 121 0800	1	Abschlussdeckel	End cover	Couvercle
11 *	1120 122 7800	1	Linsensenschraube	Oval head screw	Vis à tête bombée fraisée
12 *	4116 121 5100	1	Einlassnadel	Inlet needle	Pointeau d'admission
13 *	1123 122 3001	1	Feder	Spring	Ressort
14 *	1125 121 5000	1	Einlassregelhebel	Inlet control lever	Levier de réglage d'admission
15 *	1120 121 9200	1	Achse	Spindle	Axe
16 *	1120 122 6600	1	Bundschraube	Collar screw	Vis à embase
17 *	4129 129 0902	1	Dichtung	Gasket	Joint
18 *	4129 121 4700	1	Regelmembrane	Metering diaphragm	Membrane de réglage
19 *	4140 120 2250	1	Flansch □ 17 - 20, 28	Flange □ 17 - 20, 28	Bride □ 17 - 20, 28
20 *	4226 122 7100	4	Schraube	Screw	Vis
21 *	4137 122 6300	1	Leerlaufdrehzahlschraube	Idle speed adjustment screw	Vis de réglage de régime de ralenti
23 *	1123 121 7800	1	Sieb	Strainer	Tamis
24 *	4137 122 5100	1	Austrittsventil	Outlet valve	Soupape de sortie
25 *	1130 121 5601	1	Festdüse 0.44	Fixed jet 0.44	Gicleur fixe 0.44
26 *	4119 121 0700	1	Verschlussplatte	Cup plug	Plaque de fermeture
27 *	4129 121 0700	1	Verschlussplatte	Cup plug	Plaque de fermeture
28 *	4140 121 0800	1	Abschlussdeckel	End cover	Couvercle
29 *	4226 121 2700	1	Kappe	Cap	Capuchon
30 *	4137 121 8600	1	Scheibe	Washer	Rondelle
31 *	4137 121 5602	1	Festdüse 0.46 (B)	Fixed jet 0.46 (B)	Gicleur fixe 0.46 (B)
	* 4227 007 1060	1	Satz Vergaserteile □ 8, 9, 17, 18	Set of carburetor parts □ 8, 9, 17, 18	Jeu de pièces de carburateur □ 8, 9, 17, 18

(1) FS 75, (2) FS 80, (3) FS 80 R, (4) FS 85, (5) FS 85 R, (6) FS 85 T, (7) FS 85 RX

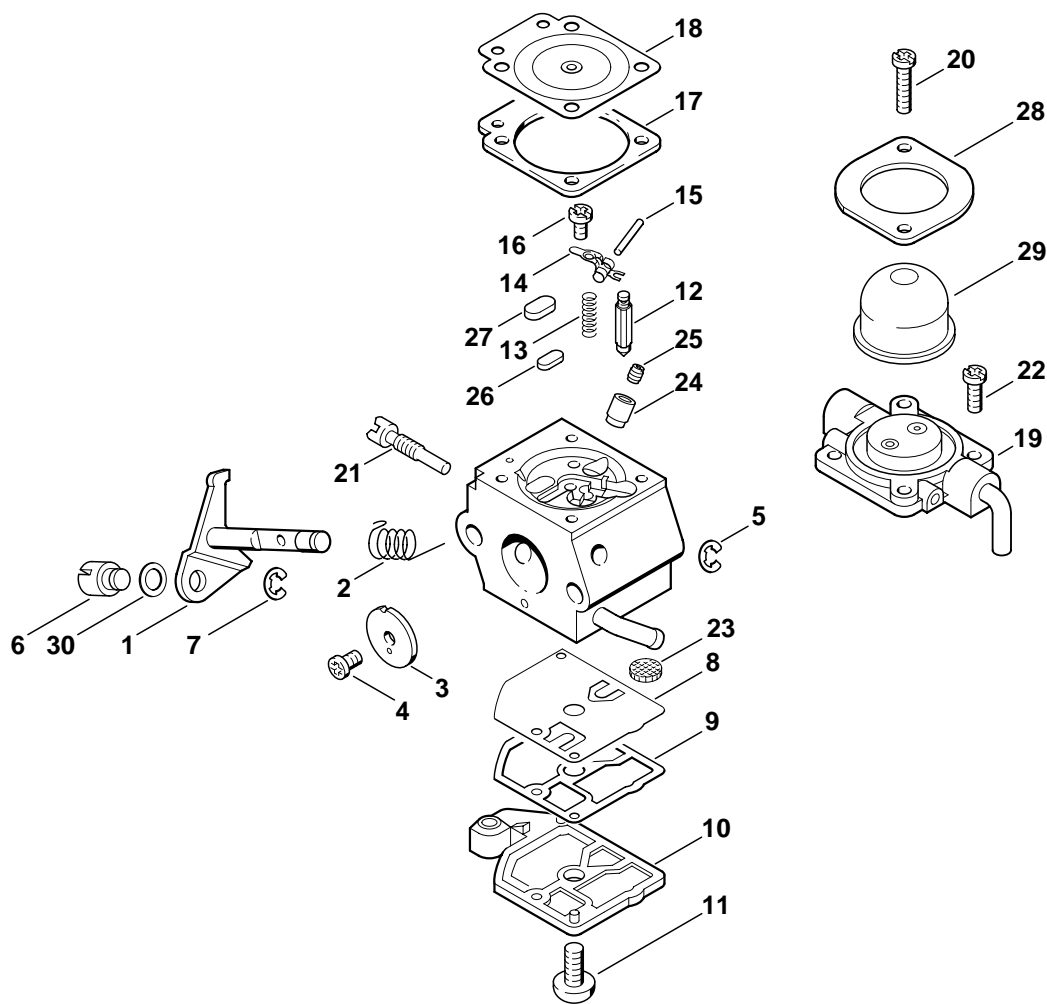

392ET038 GM

Illustration K

Vergaser C1Q-S45

Carburetor C1Q-S45

Carburateur C1Q-S45

Bild-Nr.	Teile-Nr.	St-Zahl	Benennung	Part Name	Désignation
			(16.2001)	(16.2001)	(16.2001)
	* 4137 120 0603	1	Vergaser C1Q-S45 □ 1 - 30	Carburetor C1Q-S45 □ 1 - 30	Carburateur C1Q-S45 □ 1 - 30
1 *	4226 120 7100	1	Drosselwelle mit Hebel	Throttle shaft with lever	Axe de papillon avec levier
2 *	1123 122 3000	1	Feder	Spring	Ressort
3 *	4137 121 3300	1	Drosselklappe	Throttle shutter	Papillon
4 *	1125 122 7403	1	Halbrundschraube	Round head screw	Vis à tête ronde
5 *	1125 122 9001	1	Sicherungsscheibe	E-clip	Circlips
6 *	4137 121 8900	1	Bolzen	Pin	Boulon
7 *	1120 122 9000	1	Sicherungsring	E-clip	Circlip
8 *	1129 121 4800	1	Pumpenmembrane	Pump diaphragm	Membrane de pompe
9 *	1123 129 0905	1	Dichtung	Gasket	Joint
10 *	4128 121 0800	1	Abschlussdeckel	End cover	Couvercle
11 *	1120 122 7800	1	Linsensenschraube	Oval head screw	Vis à tête bombée fraisée
12 *	4116 121 5100	1	Einlassnadel	Inlet needle	Pointeau d'admission
13 *	1123 122 3001	1	Feder	Spring	Ressort
14 *	1125 121 5000	1	Einlassregelhebel	Inlet control lever	Levier de réglage d'admission
15 *	1120 121 9200	1	Achse	Spindle	Axe
16 *	1120 122 6600	1	Bundschraube	Collar screw	Vis à embase
17 *	4129 129 0902	1	Dichtung	Gasket	Joint
18 *	4129 121 4700	1	Regelmembrane	Metering diaphragm	Membrane de réglage
19 *	4226 120 2200	1	Flansch	Flange	Bride
20 *	4226 122 7100	2	Schraube	Screw	Vis
21 *	4137 122 6300	1	Leerlaufdrehzahlschraube	Idle speed adjustment screw	Vis de réglage de régime de ralenti
22 *	1128 122 7100	2	Schraube	Screw	Vis
23 *	1123 121 7800	1	Sieb	Strainer	Tamis
24 *	4137 122 5100	1	Austrittsventil	Outlet valve	Soupape de sortie
25 *	4137 121 5601	1	Festdüse 0.42	Fixed jet 0.42	Gicleur fixe 0.42
26 *	4119 121 0700	1	Verschlussplatte	Cup plug	Plaque de fermeture
27 *	4129 121 0700	1	Verschlussplatte	Cup plug	Plaque de fermeture
28 *	4226 121 0800	1	Abschlussdeckel	End cover	Couvercle
29 *	4226 121 2700	1	Kappe	Cap	Capuchon
30 *	4137 121 8600	1	Scheibe	Washer	Rondelle
	* 4227 007 1060	1	Satz Vergaserteile □ 8, 9, 17, 18	Set of carburetor parts □ 8, 9, 17, 18	Jeu de pièces de carburateur □ 8, 9, 17, 18

(1) FS 75, (2) FS 80, (3) FS 80 R, (4) FS 85, (5) FS 85 R, (6) FS 85 T, (7) FS 85 RX

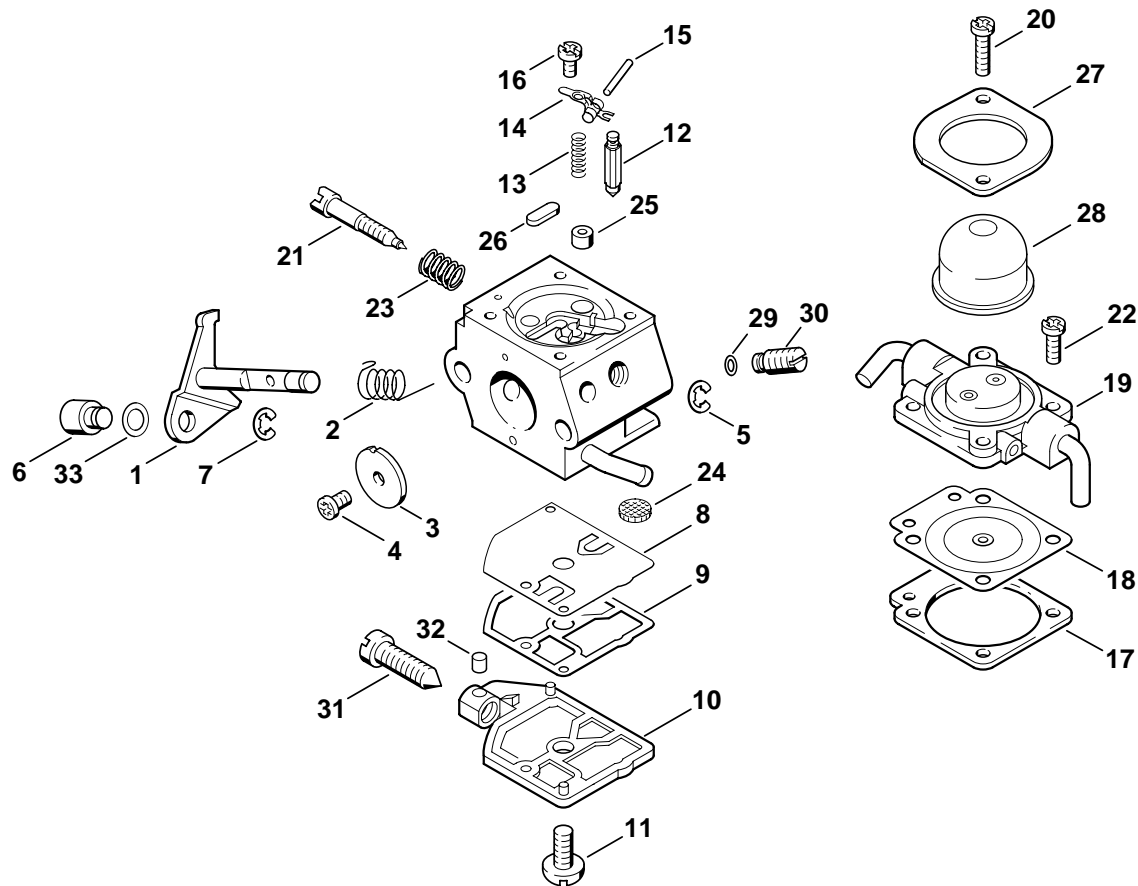

392ET040 GM

Illustration L

Vergaser C1Q-S28D,
C1Q-S41ACarburetor C1Q-S28D,
C1Q-S41ACarburateur C1Q-S28D,
C1Q-S41A

Bild-Nr.	Teile-Nr.	St-Zahl	Benennung	Part Name	Désignation
			➔ 1 42 812 153 (21.1999)	➔ 1 42 812 153 (21.1999)	➔ 1 42 812 153 (21.1999)
* 4137	120 0600	1	Vergaser C1Q-S28D □ 1 - 33	Carburetor C1Q-S28D □ 1 - 33	Carburateur C1Q-S28D □ 1 - 33
* 4137	120 0602	1	Vergaser C1Q-S41A □ 1 - 28, 31 - 33	Carburetor C1Q-S41A □ 1 - 28, 31 - 33	Carburateur C1Q-S41A □ 1 - 28, 31 - 33
1 *	4226 120 7100	1	Drosselwelle mit Hebel	Throttle shaft with lever	Axe de papillon avec levier
2 *	1123 122 3000	1	Feder	Spring	Ressort
3 *	4227 121 3300	1	Drosselklappe	Throttle shutter	Papillon
4 *	1125 122 7403	1	Halbrundschraube	Round head screw	Vis à tête ronde
5 *	1125 122 9001	1	Sicherungsscheibe	E-clip	Circlips
6 *	4128 121 8900	1	Bolzen	Pin	Boulon
7 *	1120 122 9000	1	Sicherungsring	E-clip	Circlip
8 *	1129 121 4800	1	Pumpenmembrane	Pump diaphragm	Membrane de pompe
9 *	1123 129 0905	1	Dichtung	Gasket	Joint
10 *	1123 121 0800	1	Abschlussdeckel	End cover	Couvercle
11 *	1120 122 7800	1	Linsensenkschraube	Oval head screw	Vis à tête bombée fraisée
12 *	4116 121 5100	1	Einlassnadel	Inlet needle	Pointeau d'admission
13 *	1123 122 3001	1	Feder	Spring	Ressort
14 *	1125 121 5000	1	Einlassregelhebel	Inlet control lever	Levier de réglage d'admission
15 *	1120 121 9200	1	Achse	Spindle	Axe
16 *	1120 122 6600	1	Bundschrabe	Collar screw	Vis à embase
17 *	4129 129 0902	1	Dichtung	Gasket	Joint
18 *	4129 121 4700	1	Regelmembrane	Metering diaphragm	Membrane de réglage
19 *	4226 120 2200	1	Flansch	Flange	Bride
20 *	4226 122 7100	2	Schraube	Screw	Vis
21 *	4137 122 6800	1	Leerlaufstellschraube	Low speed adjustment screw	Vis L de richesse au ralenti
22 *	1128 122 7100	2	Schraube	Screw	Vis
23 *	1120 122 3005	1	Feder	Spring	Ressort
24 *	1123 121 7800	1	Sieb	Strainer	Tamis
25 *	4137 121 5401	1	Ventildüse	Valve jet	Gicleur à soupape
26 *	4226 121 0700	1	Verschlussplatte	Cup plug	Plaque de fermeture
27 *	4226 121 0800	1	Abschlussdeckel	End cover	Couvercle
28 *	4226 121 2700	1	Kappe	Cap	Capuchon
29 *	4226 121 8600	1	Scheibe	Washer	Rondelle
30 *	4137 120 8700	1	Regelventil	Control valve	Soupape de réglage
31 *	1123 122 6200	1	Leerlaufanschlagschraube	Idle speed adjustment screw	Vis de réglage de régime de ralenti
32 *	1125 122 4200	1	Kugel	Ball	Bille
33 *	4137 121 8600	1	Scheibe	Washer	Rondelle
* 4227	007 1060	1	Satz Vergaserteile □ 8, 9, 17, 18	Set of carburetor parts □ 8, 9, 17, 18	Jeu de pièces de carburateur □ 8, 9, 17, 18

(1) FS 75, (2) FS 80, (3) FS 80 R, (4) FS 85, (5) FS 85 R, (6) FS 85 T, (7) FS 85 RX

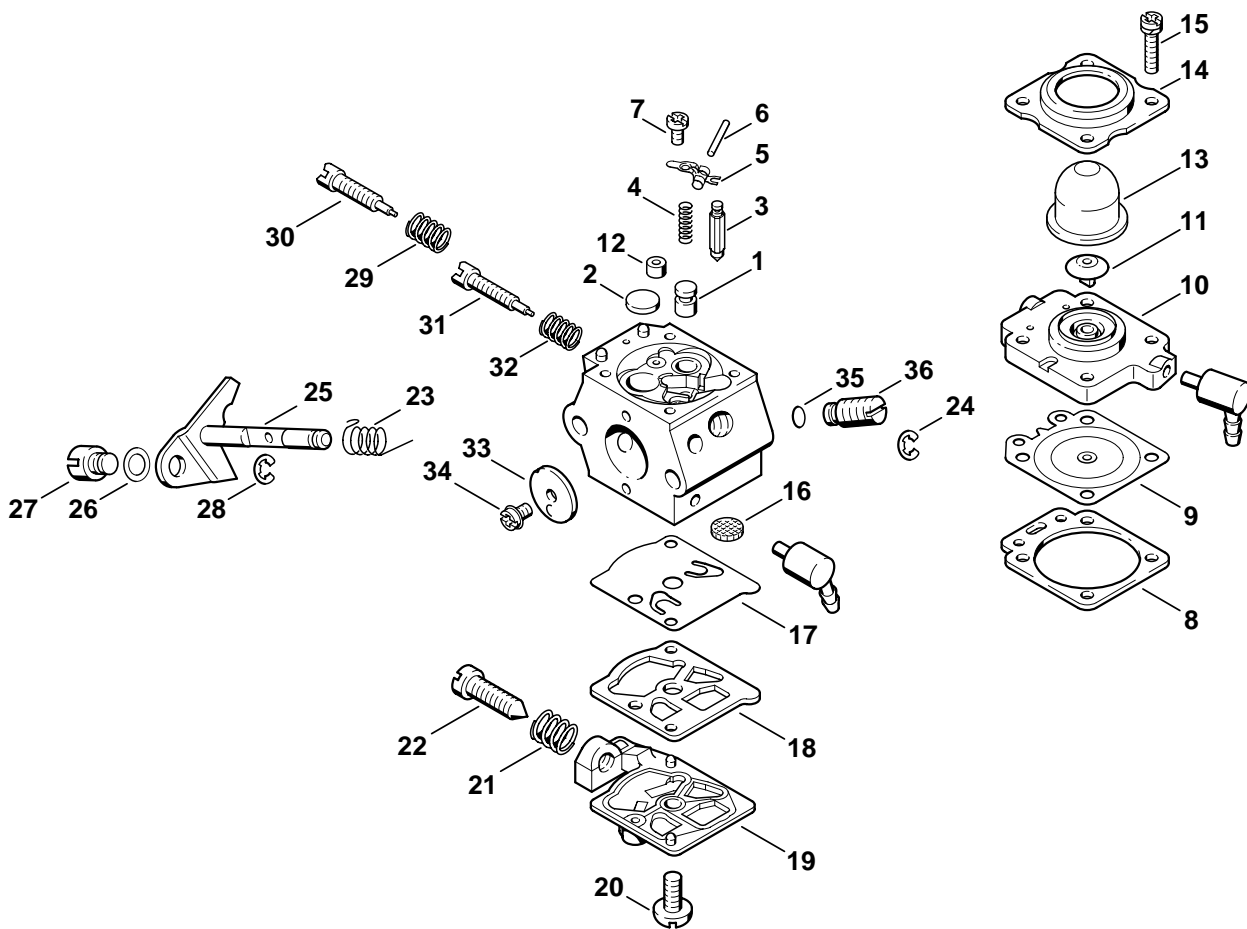

392ET005 GM

Bild-Nr.	Teile-Nr.	St-Zahl	Benennung	Part Name	Désignation
	* 4137 120 0601	1	Vergaser WT-447 (C) □ 1 - 36	Carburetor WT-447 (C) □ 1 - 36	Carburateur WT-447 (C) □ 1 - 36
1 *	4133 121 5400	1	Ventildüse	Valve jet	Gicleur à soupape
2 *	4117 122 9402	1	Verschlussstopfen	Plug	Bouchon
3 *	1110 121 5100	1	Einlassnadel	Inlet needle	Pointeau d'admission
4 *	1120 122 3001	1	Feder	Spring	Ressort
5 *	1113 121 5000	1	Einlassregelhebel	Inlet control lever	Levier de réglage d'admission
6 *	1113 121 9200	1	Achse	Spindle	Axe
7 *	1114 122 7400	1	Halbrundschraube	Round head screw	Vis à tête ronde
8 *	4133 129 0901	1	Dichtung	Gasket	Joint
9 *	1113 121 4705	1	Regelmembrane	Metering diaphragm	Membrane de réglage
10 *	4133 120 2201	1	Flansch □ 11	Flange □ 11	Bride □ 11
11 *	4133 121 5200	1	Ventil	Valve	Soupape
12 *	4133 120 8600	1	Rückschlagventil	Non-return valve	Soupape de retenue
13 *	4133 121 2700	1	Kappe	Cap	Capuchon
14 *	4133 121 0801	1	Abschlussdeckel	End cover	Couvercle
15 *	4133 122 7400	4	Halbrundschraube	Round head screw	Vis à tête ronde
16 *	1114 121 7800	1	Sieb	Strainer	Tamis
17 *	1120 121 4805	1	Pumpenmembrane	Pump diaphragm	Membrane de pompe
18 *	1120 129 0905	1	Dichtung	Gasket	Joint
19 *	4117 121 0803	1	Abschlussdeckel	End cover	Couvercle
20 *	1114 122 7100	1	Schraube	Screw	Vis
21 *	4117 122 3006	1	Feder	Spring	Ressort
22 *	4117 122 6200	1	Leerlaufanschlagschraube	Idle speed adjustment screw	Vis de réglage de régime de ralenti
23 *	4133 122 3200	1	Schenkelfeder	Torsion spring	Ressort coudé
24 *	1117 122 9000	1	Sicherungsscheibe	E-clip	Circlips
25 *	4211 120 7100	1	Drosselwelle mit Hebel	Throttle shaft with lever	Axe de papillon avec levier
26 *	4211 121 8600	1	Scheibe	Washer	Rondelle
27 *	4215 121 8900	1	Bolzen	Pin	Boulon
28 *	4211 122 9000	1	Sicherungsscheibe	E-clip	Circlips
29 *	4117 122 3007	1	Feder	Spring	Ressort
30 *	4211 122 6700	1	Hauptstellschraube	High speed adjustment screw	Vis H de richesse à haut régime
31 *	1123 122 6801	1	Leerlaufstellschraube	Low speed adjustment screw	Vis L de richesse au ralenti
32 *	1115 122 3002	1	Feder	Spring	Ressort
33 *	4117 121 3300	1	Drosselklappe	Throttle shutter	Papillon
34 *	1110 122 7400	1	Halbrundschraube	Round head screw	Vis à tête ronde
35 *	4130 121 8600	1	Scheibe	Washer	Rondelle
36 *	4133 120 8701	1	Regelventil	Control valve	Soupape de réglage
	* 4133 007 1060	1	Satz Vergaserteile □ 8, 9, 17, 18	Set of carburetor parts □ 8, 9, 17, 18	Jeu de pièces de carburateur □ 8, 9, 17, 18

(1) FS 75, (2) FS 80, (3) FS 80 R, (4) FS 85, (5) FS 85 R, (6) FS 85 T, (7) FS 85 RX

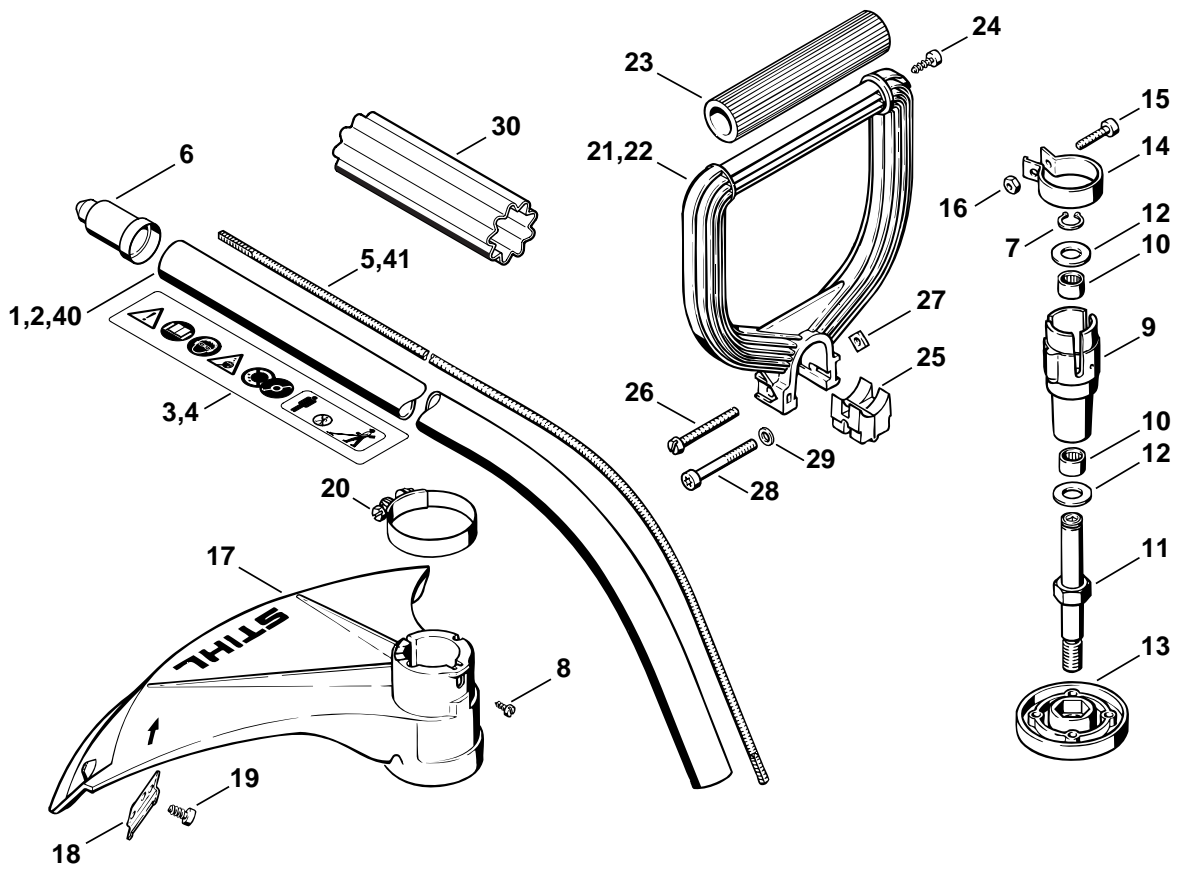

392ET068 SC

Illustration N

Schaft FS 75, Rundumgriff

Drive tube assembly FS 75,
Loop handle

Tube complet FS 75,
Poignée circulaire

Bild-Nr.	Teile-Nr.	St-Zahl	Benennung	Part Name	Désignation
1	4137 710 7113	1	Schaft Ø 25,4 mm (1) □ 3	Drive tube assembly Ø 25.4mm / 1" (1) □ 3	Tube complet Ø 25,4 mm (1) □ 3
2	4137 710 7112	1	Schaft Ø 25,4 mm USA, CDN, AUS (1) □ 4	Drive tube assembly Ø 25.4mm / 1" USA, CDN, AUS (1) □ 4	Tube complet Ø 25,4 mm USA, CDN, AUS (1) □ 4
3	0000 967 3726	1	Warnhinweis Piktogramm FS (1)	Warning pictogram FS (1)	Pictogramme d'avertissement FS (1)
4	0000 967 3659	1	Warnhinweis Piktogramm FS USA, CDN, AUS (1)	Warning pictogram FS USA, CDN, AUS (1)	Pictogramme d'avertissement FS USA, CDN, AUS (1)
5	4130 711 3210	1	Antriebswelle (1)	Drive shaft (1)	Arbre d'entraînement (1)
6	4133 717 2000	1	Kappe (1)	Cap (1)	Chapeau de roue (1)
7	9455 621 1130	1	Sicherungsring DIN471-12x1 (1)	Circlip 12x1 (1)	Circlips 12x1 (1)
8	9099 021 2360	1	Schraube DIN7971-3,5x9,5 (1)	Self-tapping screw 3.5x9.5 (1)	Vis Parker 3,5x9,5 (1)
9	4130 640 1405	1	Lagergehäuse (1) □ 7 - 12	Bearing housing (1) □ 7 - 12	Carter de logement (1) □ 7 - 12
10	9513 003 3210	2	Nadelhülse 12x16x10 (1)	Needle cage 12x16x10 (1)	Douille à aiguilles 12x16x10 (1)
11	4130 640 2205	1	Antriebswelle (1)	Drive shaft (1)	Arbre d'entraînement (1)
12	0000 958 1233	2	Scheibe (1)	Washer (1)	Rondelle (1)
13	4130 713 1501	1	Druckteller (1)	Thrust plate (1)	Disque de pression (1)
14	4130 710 6701	1	Spannschelle (1) □ 15, 16	Hose clamp (1) □ 15, 16	Collier de serrage (1) □ 15, 16
15	9022 341 1050	1	Schraube IS-M5x25-10.9 (1)	Spline screw IS-M5x25 (1)	Vis cylindrique IS-M5x25 (1)
16	9210 260 0700	1	Mutter DIN934-M5-8 (1)	Hexagon nut M5 (1)	Ecrou à six pans M5 (1)
17	4130 713 4501	1	Schutz (1)	Deflector (1)	Capot protecteur (1)
18	4130 713 4100	1	Ablängmesser (1)	Blade (1)	Couteau (1)
19	9074 478 4405	1	Schraube IS-P6x14 (1)	Pan head self-tapping screw IS-P6x14 (1)	Vis cylindrique IS-P6x14 (1)
20	9771 021 2760	1	Spannschelle 1 7/8"x1/2" (1)	Hose clip Ø 1 7/8x1/2" (1)	Collier de serrage Ø 1 7/8x1/2" (1)

(1) FS 75, (2) FS 80, (3) FS 80 R, (4) FS 85, (5) FS 85 R, (6) FS 85 T, (7) FS 85 RX

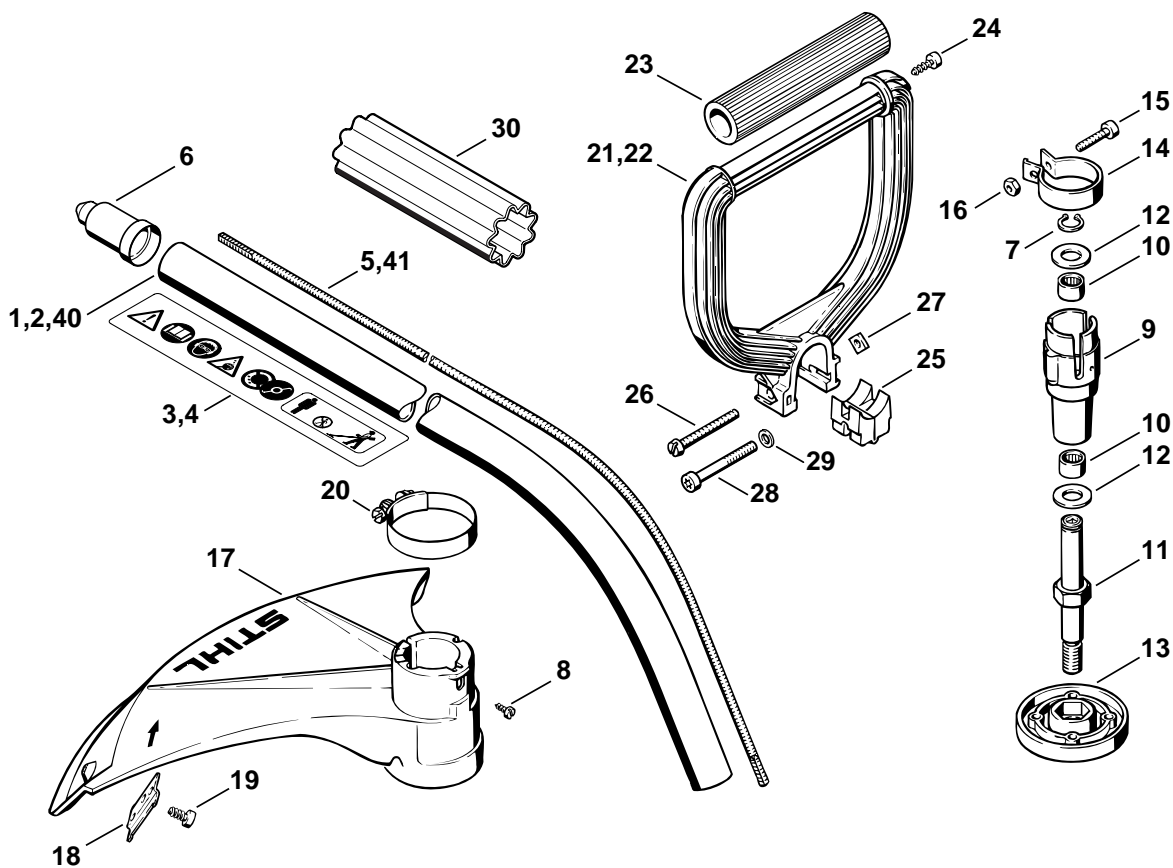

392ET068 SC

Illustration N

Schaft FS 75, Rundumgriff

Drive tube assembly FS 75,
Loop handle

Tube complet FS 75,
Poignée circulaire

Bild-Nr.	Teile-Nr.	St-Zahl	Benennung	Part Name	Désignation
21	4130 790 1300	1	Rundumgriff (1) □ 23 - 27	Loop handle (1) □ 23 - 27	Poignée circulaire (1) □ 23 - 27
22	4130 790 1200	1	Bügelgriff nur in Brasilien erhältlich (1) □ 23 - 25, 28, 29	Loop handle available in Brazil only (1) □ 23 - 25, 28, 29	Poignée en arc seulement livrable au Brésil (1) □ 23 - 25, 28, 29
23	4130 791 2000	1	Griffschlauch (1)	Handle hose (1)	Gaine de poignée (1)
24	9075 478 4115	1	Schraube IS-D5x16 (1)	Pan head self-tapping screw IS-D5x16 (1)	Vis cylindrique IS-D5x16 (1)
25	4130 791 6805	1	Klemmstück (1)	Clamp (1)	Pièce de serrage (1)
26	9041 116 1430	1	Schraube DIN84-M6x50-8.8 (1)	Pan head screw M6x50 (1)	Vis cylindrique M6x50 (1)
27	9222 068 0900	1	Mutter DIN557-M6-5 (1)	Square nut M6 (1)	Ecrou à quatre pans M6 (1)
28	9022 341 1430	1	Schraube IS-M6x50x24-10.9 nur in Brasilien erhältlich (1)	Spline screw IS-M6x50 available in Brazil only (1)	Vis cylindrique IS-M6x50 seulement livrable au Brésil (1)
29	9294 021 0140	1	Scheibe DIN433-6,4 nur in Brasilien erhältlich (1)	Washer 6.4 available in Brazil only (1)	Rondelle 6,4 seulement livrable au Brésil (1)
30	0000 711 2500	1	Hülse (1)	Sleeve (1)	Douille (1)
40 *	4133 710 7100	1	→ 36 865 749 (35.97) Schaft Ø 25,4 mm (1)	→ 36 865 749 (35.97) Drive tube assembly Ø 25.4mm / 1" (1)	→ 36 865 749 (35.97) Tube complet Ø 25,4 mm (1)
41 *	4130 711 3200	1	Antriebswelle (1)	Drive shaft (1)	Arbre d'entraînement (1)

(1) FS 75, (2) FS 80, (3) FS 80 R, (4) FS 85, (5) FS 85 R, (6) FS 85 T, (7) FS 85 RX

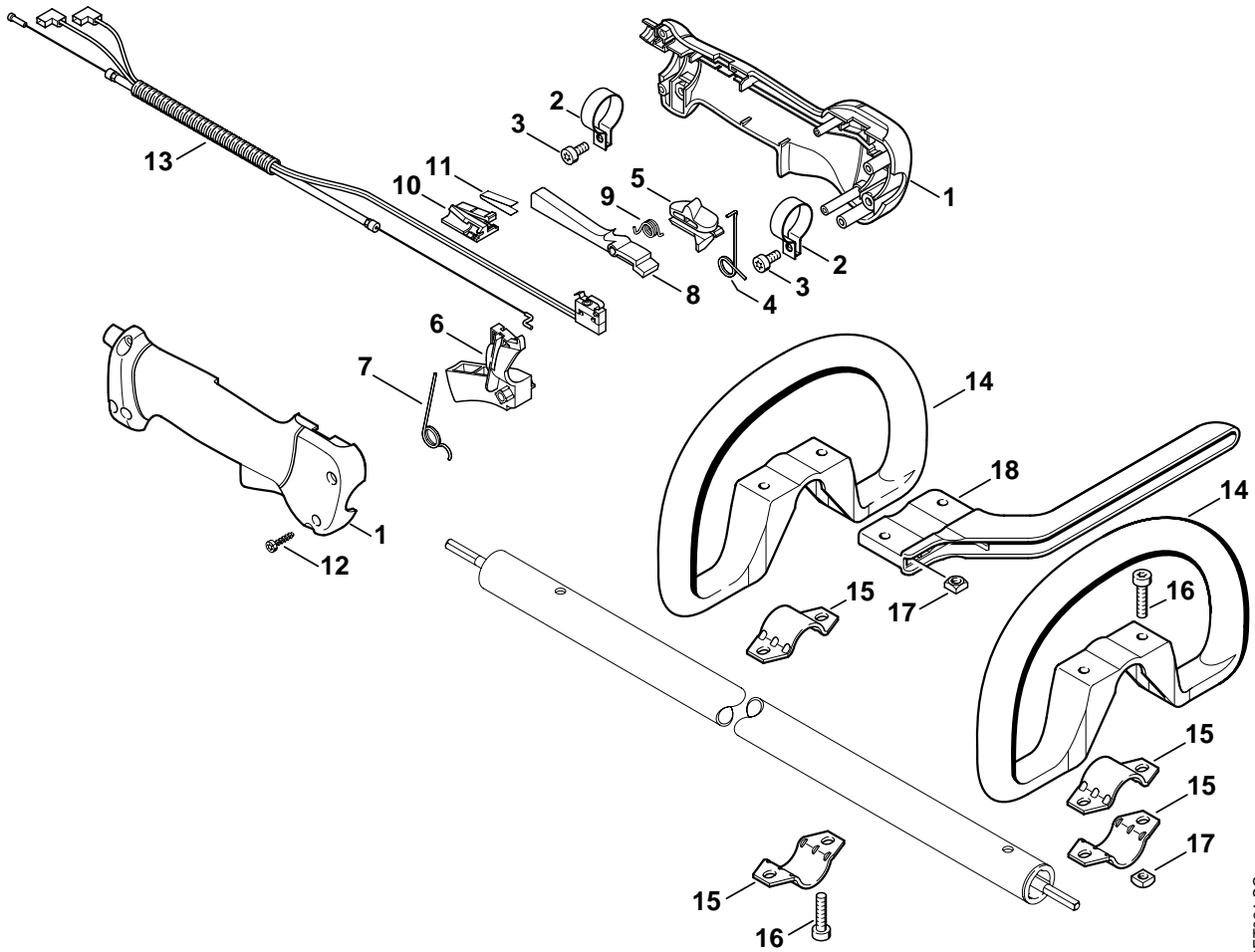

392ET061 SC

Illustration O

Handgriff

Handle

Poignée

Bild-Nr.	Teile-Nr.	St-Zahl	Benennung	Part Name	Désignation
	4137 790 1307	1	Bedienungsgriff (1,3,5,6,7) □ 1 - 12	Control handle (1,3,5,6,7) □ 1 - 12	Poignée de commande (1,3,5,6,7) □ 1 - 12
1	4137 790 0300	1	Handgriff (1,3,5,6,7)	Handle (1,3,5,6,7)	Poignée (1,3,5,6,7)
2	4137 791 9400	2	Spannschelle (1,3,5,6,7)	Hose clamp (1,3,5,6,7)	Collier de serrage (1,3,5,6,7)
3	9022 341 0960	2	Schraube IS-M5x12-10.9 (1,3,5,6,7)	Spline screw IS-M5x12 (1,3,5,6,7)	Vis cylindrique IS-M5x12 (1,3,5,6,7)
4	4137 182 4505	1	Schenkelfeder (1,3,5,6,7)	Torsion spring (1,3,5,6,7)	Ressort coudé (1,3,5,6,7)
5	4137 182 1701	1	Kombischieber (1,3,5,6,7)	Slide control (1,3,5,6,7)	Curseur combiné (1,3,5,6,7)
6	4137 182 1001	1	Gashebel (1,3,5,6,7)	Throttle trigger (1,3,5,6,7)	Manette des gaz (1,3,5,6,7)
7	4137 182 4504	1	Schenkelfeder (1,3,5,6,7)	Torsion spring (1,3,5,6,7)	Ressort coudé (1,3,5,6,7)
8	4137 182 0802	1	Sperrhebel (1,3,5,6,7)	Trigger interlock (1,3,5,6,7)	Levier d'arrêt (1,3,5,6,7)
9	4128 182 4501	1	Schenkelfeder (1,3,5,6,7)	Torsion spring (1,3,5,6,7)	Ressort coudé (1,3,5,6,7)
10	4128 793 3000	1	Schieber (1,3,5,6,7)	Slide (1,3,5,6,7)	Curseur (1,3,5,6,7)
11	4128 791 3100	1	Feder (1,3,5,6,7)	Spring (1,3,5,6,7)	Ressort (1,3,5,6,7)
12	9074 478 3025	4	Schraube IS-P4x16 (1,3,5,6,7)	Pan head self-tapping screw IS-P4x16 (1,3,5,6,7)	Vis cylindrique IS-P4x16 (1,3,5,6,7)
13	4137 180 1107	1	Gaszug (1,3,5,6,7)	Throttle cable (1,3,5,6,7)	Câble de commande des gaz (1,3,5,6,7)
14	4130 790 1316	1	Rundumgriff (1,3,5,6,7) □ 15 - 17	Loop handle (1,3,5,6,7) □ 15 - 17	Poignée circulaire (1,3,5,6,7) □ 15 - 17
15	4123 791 7400	2	Lasche (1,3,5,6,7)	Clamp (1,3,5,6,7)	Bride de fixation (1,3,5,6,7)
16	9022 341 1350	2	Schraube IS-M6x25-10.9 (1,3,5,6,7)	Spline screw IS-M6x25 (1,3,5,6,7)	Vis cylindrique IS-M6x25 (1,3,5,6,7)
17	9222 068 0900	2	Mutter DIN557-M6-5 (1,3,5,6,7)	Square nut M6 (1,3,5,6,7)	Ecrou à quatre pans M6 (1,3,5,6,7)
18	4130 791 4400	1	Bügel (1,3,5,6,7)	Barrier bar (1,3,5,6,7)	Etrier (1,3,5,6,7)

(1) FS 75, (2) FS 80, (3) FS 80 R, (4) FS 85, (5) FS 85 R, (6) FS 85 T, (7) FS 85 RX

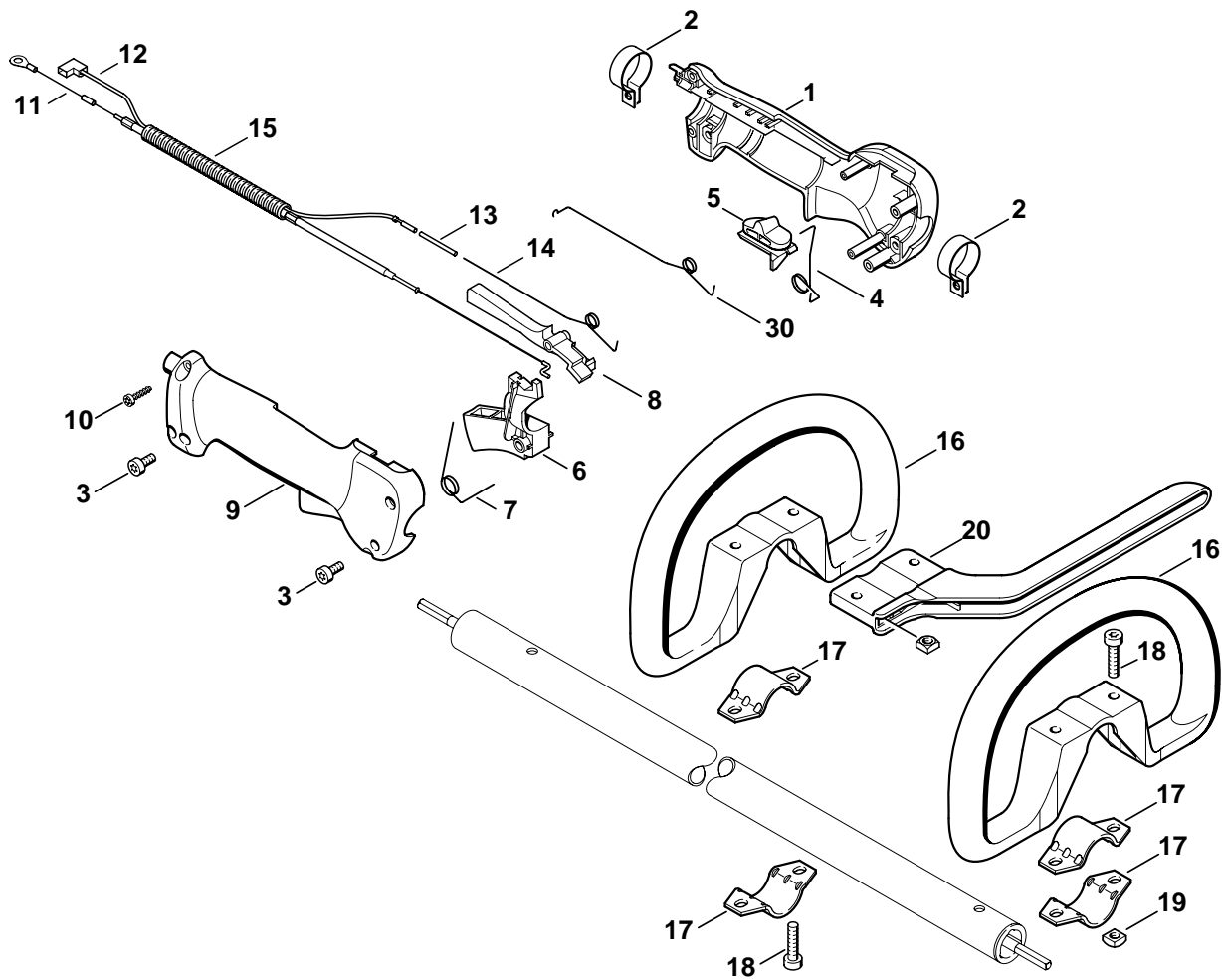

392ET044 SC

Illustration P

Handgriff

Handle

Poignée

Bild-Nr.	Teile-Nr.	St-Zahl	Benennung	Part Name	Désignation
			(24.2002)	(24.2002)	(24.2002)
* 4137	790 1350	1	Bedienungsgriff (1,3,5,6,7) □ 1 - 10	Control handle (1,3,5,6,7) □ 1 - 10	Poignée de commande (1,3,5,6,7) □ 1 - 10
1 *	4137 790 1101	1	Griffhälfte innen (1,3,5,6,7)	Handle molding, inner (1,3,5,6,7)	Monture de poignée intérieure (1,3,5,6,7)
2 *	4137 791 9400	2	Spannschelle (1,3,5,6,7)	Hose clamp (1,3,5,6,7)	Collier de serrage (1,3,5,6,7)
3 *	9022 341 0960	2	Schraube IS-M5x12-10.9 (1,3,5,6,7)	Spline screw IS-M5x12 (1,3,5,6,7)	Vis cylindrique IS-M5x12 (1,3,5,6,7)
4 *	4137 442 1600	1	Kontaktfeder (1,3,5,6,7)	Contact spring (1,3,5,6,7)	Ressort de connexion (1,3,5,6,7)
5 *	4137 182 1700	1	Kombischieber (1,3,5,6,7)	Slide control (1,3,5,6,7)	Curseur combiné (1,3,5,6,7)
6 *	4137 182 1000	1	Gashebel (1,3,5,6,7)	Throttle trigger (1,3,5,6,7)	Manette des gaz (1,3,5,6,7)
7 *	4137 182 4500	1	Schenkelfeder (1,3,5,6,7)	Torsion spring (1,3,5,6,7)	Ressort coudé (1,3,5,6,7)
8 *	4137 182 0801	1	Sperrhebel (1,3,5,6,7)	Trigger interlock (1,3,5,6,7)	Levier d'arrêt (1,3,5,6,7)
9 *	4137 791 0800	1	Griffhälfte außen (1,3,5,6,7)	Handle molding, outer (1,3,5,6,7)	Monture de poignée extérieure (1,3,5,6,7)
10 *	9074 478 3025	4	Schraube IS-P4x16 (1,3,5,6,7)	Pan head self-tapping screw IS-P4x16 (1,3,5,6,7)	Vis cylindrique IS-P4x16 (1,3,5,6,7)
11 *	4137 180 1103	1	Gaszug (1,3,5,6,7) □ 12 - 15	Throttle cable (1,3,5,6,7) □ 12 - 15	Câble de commande des gaz (1,3,5,6,7) □ 12 - 15
11 *	4137 180 1150	1	Gaszug (1,3,5,6,7) □ 1, 8, 12 - 15	Throttle cable (1,3,5,6,7) □ 1, 8, 12 - 15	Câble de commande des gaz (1,3,5,6,7) □ 1, 8, 12 - 15
12 *	4137 440 1101	1	KurzschlieÙleitung (1,3,5,6,7)	Short circuit wire (1,3,5,6,7)	Câble de court-circuit (1,3,5,6,7)
13 *	0000 442 2100	1	Schrumpfschlauch (1,3,5,6,7)	Hose (1,3,5,6,7)	Gaine thermorétractable (1,3,5,6,7)
14 *	4137 182 4503	1	Schenkelfeder (1,3,5,6,7)	Torsion spring (1,3,5,6,7)	Ressort coudé (1,3,5,6,7)
15 *		1	Schlauch 185 mm (D) (1,3,5,6,7)	Hose 185mm / 7 5/16" (D) (1,3,5,6,7)	Tuyau 185 mm (D) (1,3,5,6,7)
	* 4203 711 7201	1	Schlauch 960 mm (1,3,5,6,7)	Hose 960mm / 37 13/16" (1,3,5,6,7)	Tuyau 960 mm (1,3,5,6,7)

(1) FS 75, (2) FS 80, (3) FS 80 R, (4) FS 85, (5) FS 85 R, (6) FS 85 T, (7) FS 85 RX

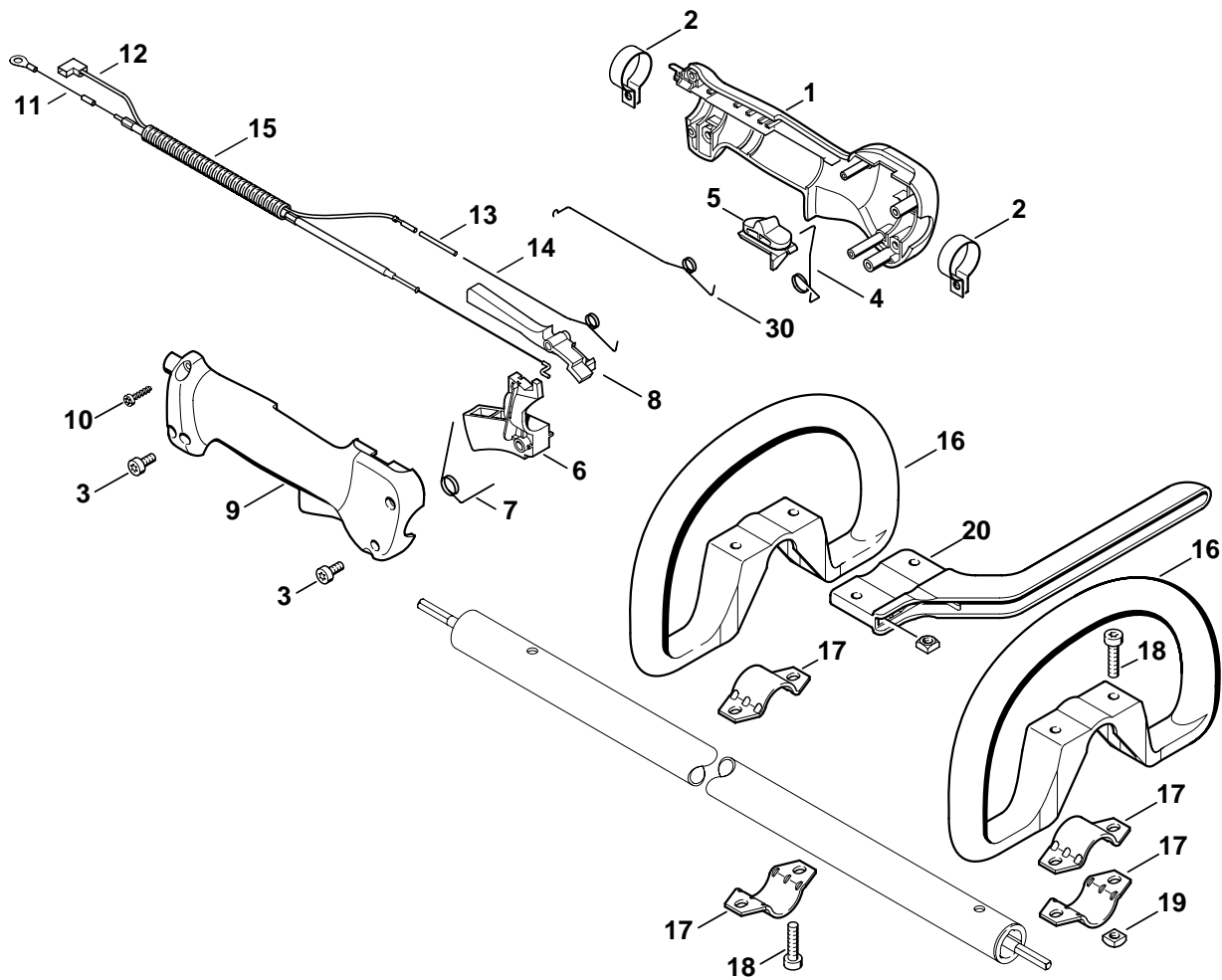

392ET044 SC

Illustration P

Handgriff

Handle

Poignée

Bild-Nr.	Teile-Nr.	St-Zahl	Benennung	Part Name	Désignation
			(24.2002)	(24.2002)	(24.2002)
16 *	4130 790 1316	1	Rundumgriff (1,3,5,6,7) □ 17 - 19	Loop handle (1,3,5,6,7) □ 17 - 19	Poignée circulaire (1,3,5,6,7) □ 17 - 19
17 *	4123 791 7400	2	Lasche (1,3,5,6,7)	Clamp (1,3,5,6,7)	Bride de fixation (1,3,5,6,7)
18 *	9022 341 1350	2	Schraube IS-M6x25-10.9 (1,3,5,6,7)	Spline screw IS-M6x25 (1,3,5,6,7)	Vis cylindrique IS-M6x25 (1,3,5,6,7)
19 *	9222 068 0900	2	Mutter DIN557-M6-5 (1,3,5,6,7)	Square nut M6 (1,3,5,6,7)	Ecrou à quatre pans M6 (1,3,5,6,7)
20 *	4130 791 4400	1	Bügel (1,3,5,6,7)	Barrier bar (1,3,5,6,7)	Etrier (1,3,5,6,7)
			➔ 2 41 133 171	➔ 2 41 133 171	➔ 2 41 133 171
30 *	4137 182 4502	1	Schenkelfeder (1,3,5,6,7)	Torsion spring (1,3,5,6,7)	Ressort coudé (1,3,5,6,7)

(1) FS 75, (2) FS 80, (3) FS 80 R, (4) FS 85, (5) FS 85 R, (6) FS 85 T, (7) FS 85 RX

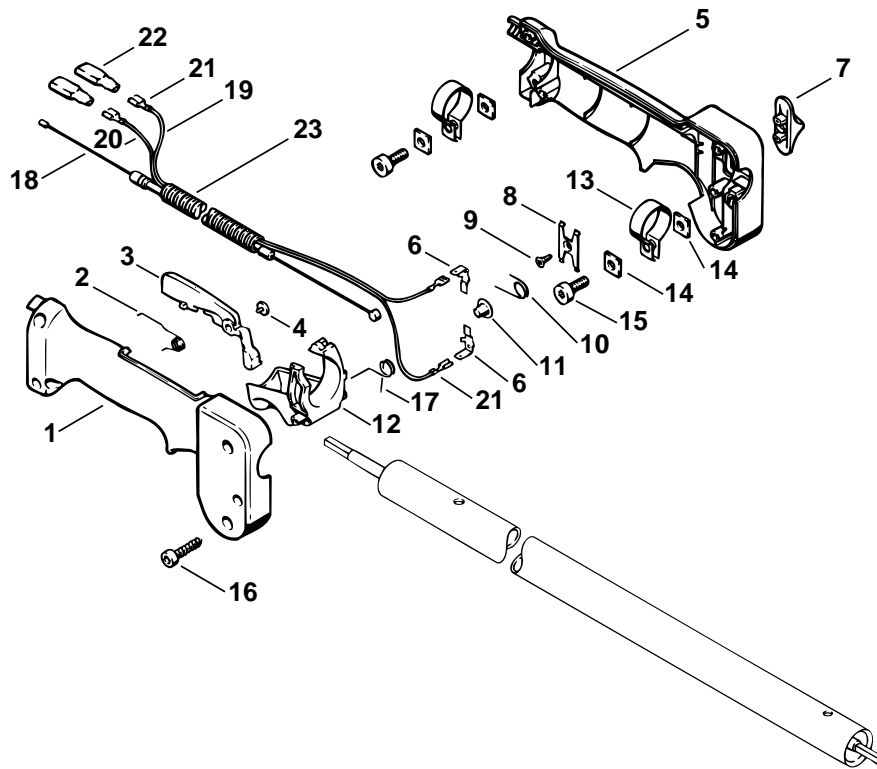

392ET018 SC

Illustration Q

Handgriff

Handle

Poignée

Bild-Nr.	Teile-Nr.	St-Zahl	Benennung	Part Name	Désignation
			(37.97)	(37.97)	(37.97)
* 4133	790 1301	1	Bedienungsgriff (1,3,5) □ 1 - 17	Control handle (1,3,5) □ 1 - 17	Poignée de commande (1,3,5) □ 1 - 17
1 *	4126 791 0821	1	Griffhälfte außen (1,3,5)	Handle molding, outer (1,3,5)	Monture de poignée extérieure (1,3,5)
2 *	4126 182 4506	1	Schenkelfeder (1,3,5)	Torsion spring (1,3,5)	Ressort coudé (1,3,5)
3 *	4126 182 0806	1	Sperrhebel (1,3,5)	Trigger interlock (1,3,5)	Levier d'arrêt (1,3,5)
4 *	4126 182 6210	1	Bundschraube (1,3,5)	Collar screw (1,3,5)	Vis à embase (1,3,5)
5 *	4126 790 1102	1	Griffhälfte innen (1,3,5) □ 6	Handle molding, inner (1,3,5) □ 6	Monture de poignée intérieure (1,3,5) □ 6
6 *	4126 791 5300	2	Steckzunge (1,3,5)	Connector tag (1,3,5)	Languette enfichable (1,3,5)
7 *	4126 182 1705	1	Kombischieber (1,3,5)	Slide control (1,3,5)	Curseur combiné (1,3,5)
8 *	4126 182 4705	1	Rastfeder (1,3,5)	Detent spring (1,3,5)	Ressort d'encliquetage (1,3,5)
9 *	4126 182 6205	1	Bundschraube (1,3,5)	Collar screw (1,3,5)	Vis à embase (1,3,5)
10 *	4126 182 4505	1	Schenkelfeder (1,3,5)	Torsion spring (1,3,5)	Ressort coudé (1,3,5)
11 *	9417 003 7510	1	Feder Mutter (1,3,5)	Push nut (1,3,5)	Clip-écrou (1,3,5)
12 *	4126 182 1007	1	Gashebel (1,3,5)	Throttle trigger (1,3,5)	Manette des gaz (1,3,5)
13 *	4133 791 9400	2	Spannschelle (1,3,5)	Hose clamp (1,3,5)	Collier de serrage (1,3,5)
14 *	4126 792 6100	4	Vierkantscheibe (1,3,5)	Square washer (1,3,5)	Rondelle à quatre pans (1,3,5)
15 *	9022 341 0980	2	Schraube IS-M5x16-12.9 (1,3,5)	Spline screw IS-M5x16 (1,3,5)	Vis cylindrique IS-M5x16 (1,3,5)
16 *	9074 478 3065	4	Schraube IS-4x19 (1,3,5)	Pan head self-tapping screw IS-P4x19 (1,3,5)	Vis cylindrique IS-P4x19 (1,3,5)
17 *	4126 182 4507	1	Schenkelfeder (1,3,5)	Torsion spring (1,3,5)	Ressort coudé (1,3,5)
18 *	4133 180 1105	1	Gaszug (1,3,5)	Throttle cable (1,3,5)	Câble de commande des gaz (1,3,5)
19 *		1	Leitung 480 mm (1,3,5)	Lead 480mm / 18.9" (1,3,5)	Câble 480 mm (1,3,5)
20 *		1	Leitung 565 mm (1,3,5)	Lead 565mm / 22.2" (1,3,5)	Câble 565 mm (1,3,5)
* 0751	010 1110	1	Leitung 10 m (A,B) (1,3,5)	Lead 10m / 33' (A,B) (1,3,5)	Conduit 10 m (A,B) (1,3,5)
21 *	0751 030 8953	4	Steckhülse 4,8-1 (1,3,5)	Terminal socket 4.8-1 (1,3,5)	Clip enfichable 4,8-1 (1,3,5)
22 *	0751 030 8470	3	Tülle (1,3,5)	Grommet (1,3,5)	Douille (1,3,5)
23 *		1	Schlauch 170 mm (1,3,5)	Hose 170mm / 6 3/4" (1,3,5)	Tuyau 170 mm (1,3,5)
* 4203	711 7201	1	Schlauch 960 mm (A,B) (1,3,5)	Hose 960mm / 37 13/16" (A,B) (1,3,5)	Tuyau 960 mm (A,B) (1,3,5)

(1) FS 75, (2) FS 80, (3) FS 80 R, (4) FS 85, (5) FS 85 R, (6) FS 85 T, (7) FS 85 RX

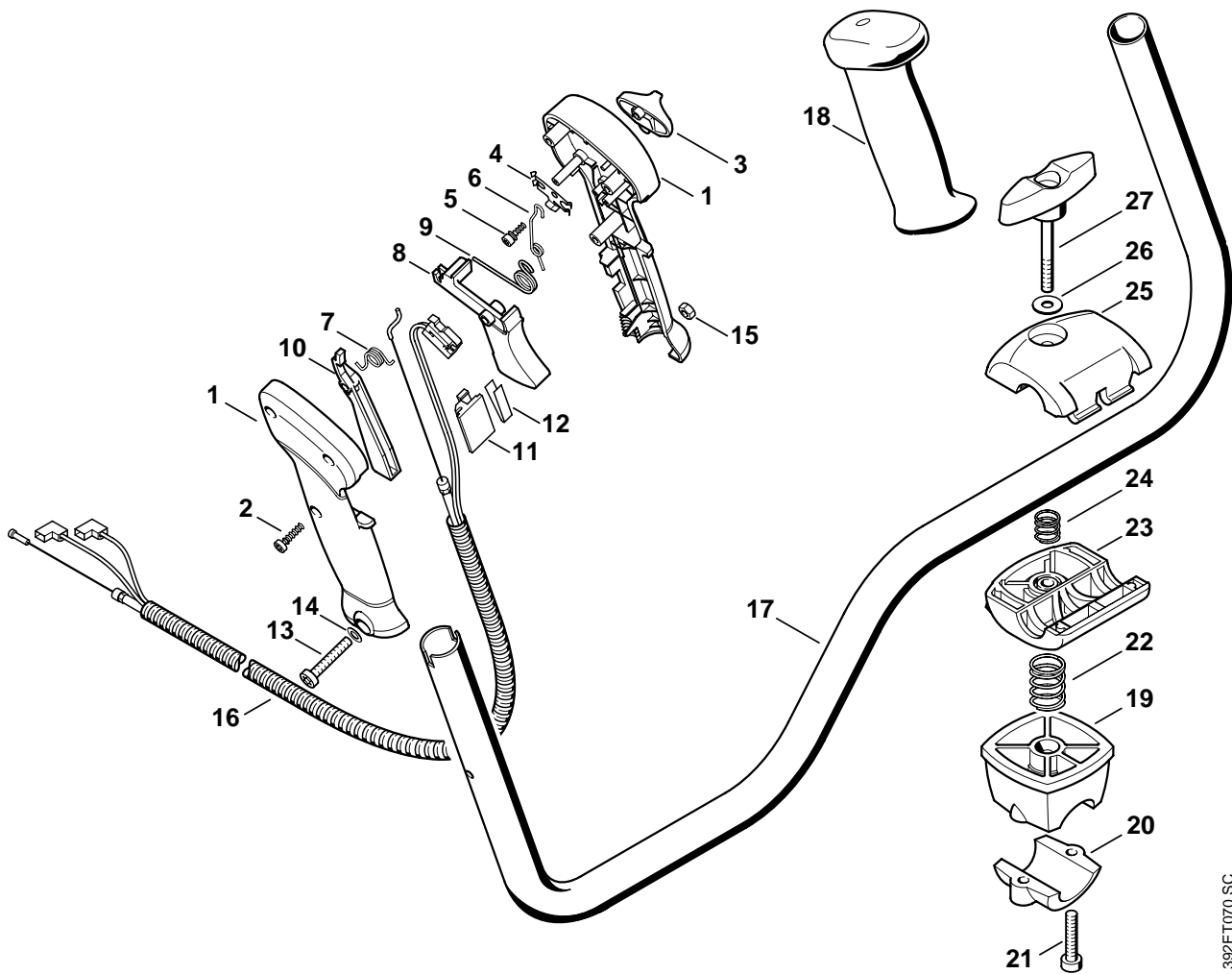

392ET070 SC

Illustration R

Zweihandgriff

Two-handed handle bar

Poignée tubulaire à deux mains

Bild-Nr.	Teile-Nr.	St-Zahl	Benennung	Part Name	Désignation
	4128 790 1301	1	Bedienungsgriff (2,4) □ 1 - 13, 15	Control handle (2,4) □ 1 - 13, 15	Poignée de commande (2,4) □ 1 - 13, 15
1	4128 790 0301	1	Handgriff rechts (2,4)	Handle, right (2,4)	Poignée droite (2,4)
2	9074 478 3025	3	Schraube IS-P4x16 (2,4)	Pan head self-tapping screw IS-P4x16 (2,4)	Vis cylindrique IS-P4x16 (2,4)
3	4128 182 1700	1	Kombischieber (2,4)	Slide control (2,4)	Curseur combiné (2,4)
4	4128 182 4201	1	Rastfeder (2,4)	Detent spring (2,4)	Ressort d'encliquetage (2,4)
5	4128 182 6200	1	Bundschraube (2,4)	Collar screw (2,4)	Vis à embase (2,4)
6	4128 182 4502	1	Schenkelfeder (2,4)	Torsion spring (2,4)	Ressort coudé (2,4)
7	4128 182 4501	1	Schenkelfeder (2,4)	Torsion spring (2,4)	Ressort coudé (2,4)
8	4128 182 1000	1	Gashebel (2,4)	Throttle trigger (2,4)	Manette des gaz (2,4)
9	4128 182 4500	1	Schenkelfeder (2,4)	Torsion spring (2,4)	Ressort coudé (2,4)
10	4128 182 0800	1	Sperrhebel (2,4)	Trigger interlock (2,4)	Levier d'arrêt (2,4)
11	4128 793 3000	1	Schieber (2,4)	Slide (2,4)	Curseur (2,4)
12	4128 791 3100	1	Feder (2,4)	Spring (2,4)	Ressort (2,4)
13	9022 346 1070	1	Schraube IS-M5x30x22-10.9 (2,4)	Spline screw IS-M5x30 (2,4)	Vis cylindrique IS-M5x30 (2,4)
14 *	9291 021 0120	1	Scheibe DIN125-A5,3 (2,4)	Washer 5.3 (2,4)	Rondelle 5,3 (2,4)
15	9214 320 0700	1	Sicherungsmutter DIN980-V M5-10 (2,4)	Lock nut M5 (2,4)	Ecrou de sécurité M5 (2,4)
16	4137 180 1109	1	Gaszug (2,4)	Throttle cable (2,4)	Câble de commande des gaz (2,4)
17	4128 790 1701	1	Griffrohr (2,4) □ 18	Handlebar (2,4) □ 18	Poignée tubulaire (2,4) □ 18
18	4128 791 0300	1	Handgriff links (2,4)	Handle, left (2,4)	Poignée gauche (2,4)
	4134 790 3200	1	Griffrohrhalter (2,4) □ 19 - 27	Handlebar support (2,4) □ 19 - 27	Crampon de tube de poignée (2,4) □ 19 - 27
19	4134 790 7600	1	Stütze (2,4)	Support (2,4)	Support (2,4)
20	4134 791 0900	1	Klemmschale (2,4)	Clamp (2,4)	Élément de serrage (2,4)
21	9022 341 1370	2	Schraube IS-M6x30-10.9 (2,4)	Spline screw IS-M6x30 (2,4)	Vis cylindrique IS-M6x30 (2,4)
22	0000 997 1701	1	Druckfeder (2,4)	Compression spring (2,4)	Ressort de pression (2,4)
23	4128 791 0905	1	Klemmschale unten (2,4)	Clamp, base (2,4)	Monture de serrage inférieure (2,4)
24	0000 997 1304	1	Druckfeder (2,4)	Compression spring (2,4)	Ressort de pression (2,4)
25	4128 791 0900	1	Klemmschale oben (2,4)	Clamp, top (2,4)	Monture de serrage supérieure (2,4)
26	0000 958 0609	1	Scheibe (2,4)	Washer (2,4)	Rondelle (2,4)
27	4128 790 7500	1	Knebelschraube (2,4)	Tommy screw (2,4)	Vis à garrot (2,4)

(1) FS 75, (2) FS 80, (3) FS 80 R, (4) FS 85, (5) FS 85 R, (6) FS 85 T, (7) FS 85 RX

Illustration S

Zweihandgriff USA, CDN,
BR, PRC

Two-handed handle bar
USA, CDN, BR, PRC

Poignée tubulaire à deux
mains USA, CDN, BR, PRC

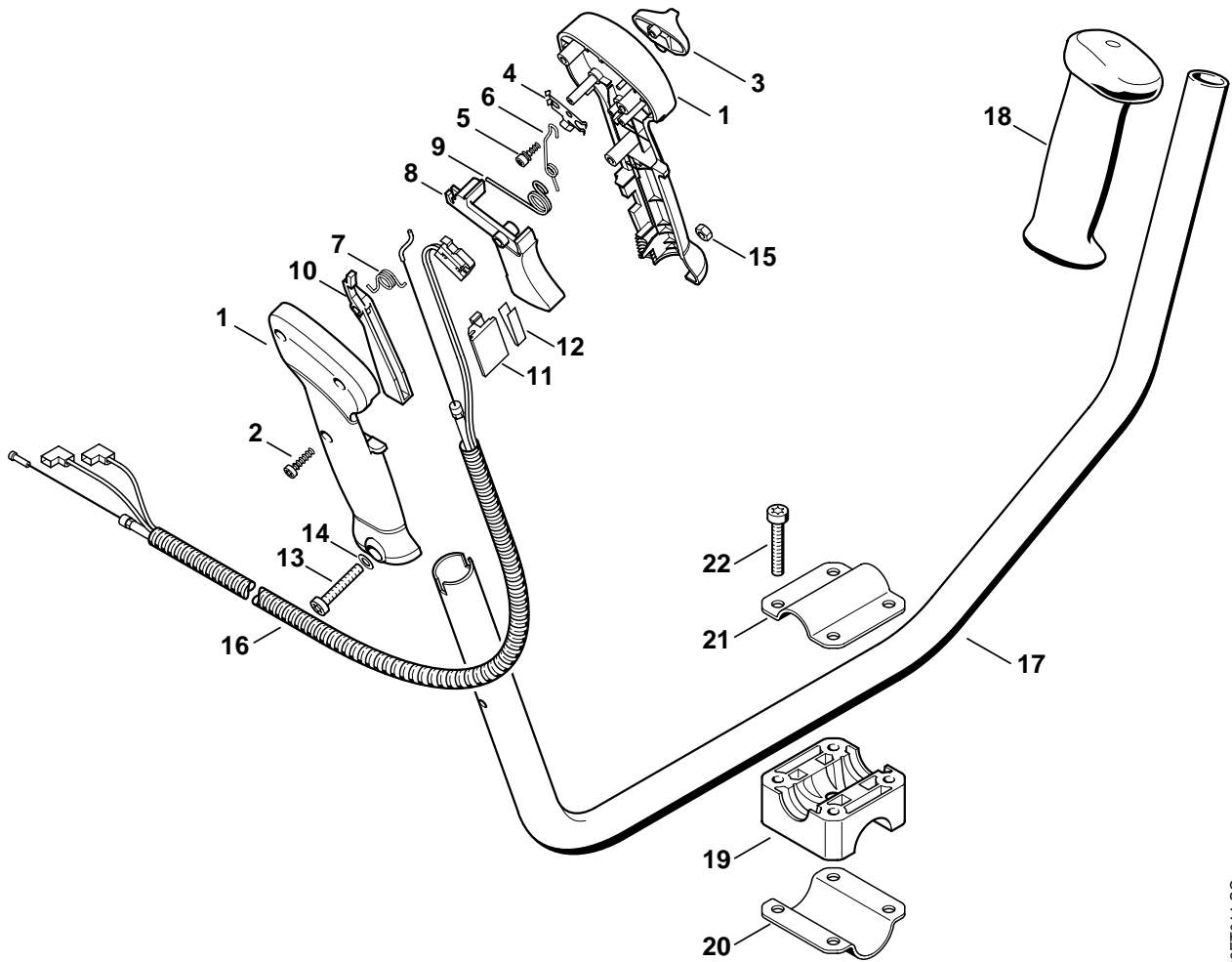

462ET011 SC

Illustration S

Zweihandgriff USA, CDN,
BR, PRC

Two-handed handle bar
USA, CDN, BR, PRC

Poignée tubulaire à deux
mains USA, CDN, BR, PRC

Bild-Nr.	Teile-Nr.	St-Zahl	Benennung	Part Name	Désignation
	4128 790 1301	1	Bedienungsgriff (2,4,6) □ 1 - 13, 15	Control handle (2,4,6) □ 1 - 13, 15	Poignée de commande (2,4,6) □ 1 - 13, 15
1	4128 790 0301	1	Handgriff rechts (2,4,6)	Handle, right (2,4,6)	Poignée droite (2,4,6)
2	9074 478 3025	3	Schraube IS-P4x16 (2,4,6)	Pan head self-tapping screw IS-P4x16 (2,4,6)	Vis cylindrique IS-P4x16 (2,4,6)
3	4128 182 1700	1	Kombischieber (2,4,6)	Slide control (2,4,6)	Curseur combiné (2,4,6)
4	4128 182 4201	1	Rastfeder (2,4,6)	Detent spring (2,4,6)	Ressort d'encliquetage (2,4,6)
5	4128 182 6200	1	Bundschrabe (2,4,6)	Collar screw (2,4,6)	Vis à embase (2,4,6)
6	4128 182 4502	1	Schenkelfeder (2,4,6)	Torsion spring (2,4,6)	Ressort coudé (2,4,6)
7	4128 182 4501	1	Schenkelfeder (2,4,6)	Torsion spring (2,4,6)	Ressort coudé (2,4,6)
8	4128 182 1000	1	Gashebel (2,4,6)	Throttle trigger (2,4,6)	Manette des gaz (2,4,6)
9	4128 182 4500	1	Schenkelfeder (2,4,6)	Torsion spring (2,4,6)	Ressort coudé (2,4,6)
10	4128 182 0800	1	Sperrhebel (2,4,6)	Trigger interlock (2,4,6)	Levier d'arrêt (2,4,6)
11	4128 793 3000	1	Schieber (2,4,6)	Slide (2,4,6)	Curseur (2,4,6)
12	4128 791 3100	1	Feder (2,4,6)	Spring (2,4,6)	Ressort (2,4,6)
13	9022 346 1070	1	Schraube IS-M5x30x22-10.9 (2,4,6)	Spline screw IS-M5x30 (2,4,6)	Vis cylindrique IS-M5x30 (2,4,6)
14 *	9291 021 0120	1	Scheibe DIN125-A5,3 (2,4,6)	Washer 5.3 (2,4,6)	Rondelle 5,3 (2,4,6)
15	9214 320 0700	1	Sicherungsmutter DIN980-V M5-10 (2,4,6)	Lock nut M5 (2,4,6)	Ecrou de sécurité M5 (2,4,6)
16	4137 180 1109	1	Gaszug (2,4,6)	Throttle cable (2,4,6)	Câble de commande des gaz (2,4,6)
17	4137 790 1701	1	Griffrohr (2,4,6) □ 18	Handlebar (2,4,6) □ 18	Poignée tubulaire (2,4,6) □ 18
18	4128 791 0300	1	Handgriff links (2,4,6)	Handle, left (2,4,6)	Poignée gauche (2,4,6)
19	4137 791 6800	1	Klemmstück (2,4,6)	Clamp (2,4,6)	Pièce de serrage (2,4,6)
20	4130 791 0606	1	Klemmschale (2,4,6)	Clamp (2,4,6)	Monture de serrage (2,4,6)
21	4137 791 0900	1	Klemmschale (2,4,6)	Clamp (2,4,6)	Monture de serrage (2,4,6)
22	9022 341 1380	4	Schraube IS-M6x35-10.9 (2,4,6)	Spline screw IS-M6x35 (2,4,6)	Vis cylindrique IS-M6x35 (2,4,6)

(1) FS 75, (2) FS 80, (3) FS 80 R, (4) FS 85, (5) FS 85 R, (6) FS 85 T, (7) FS 85 RX

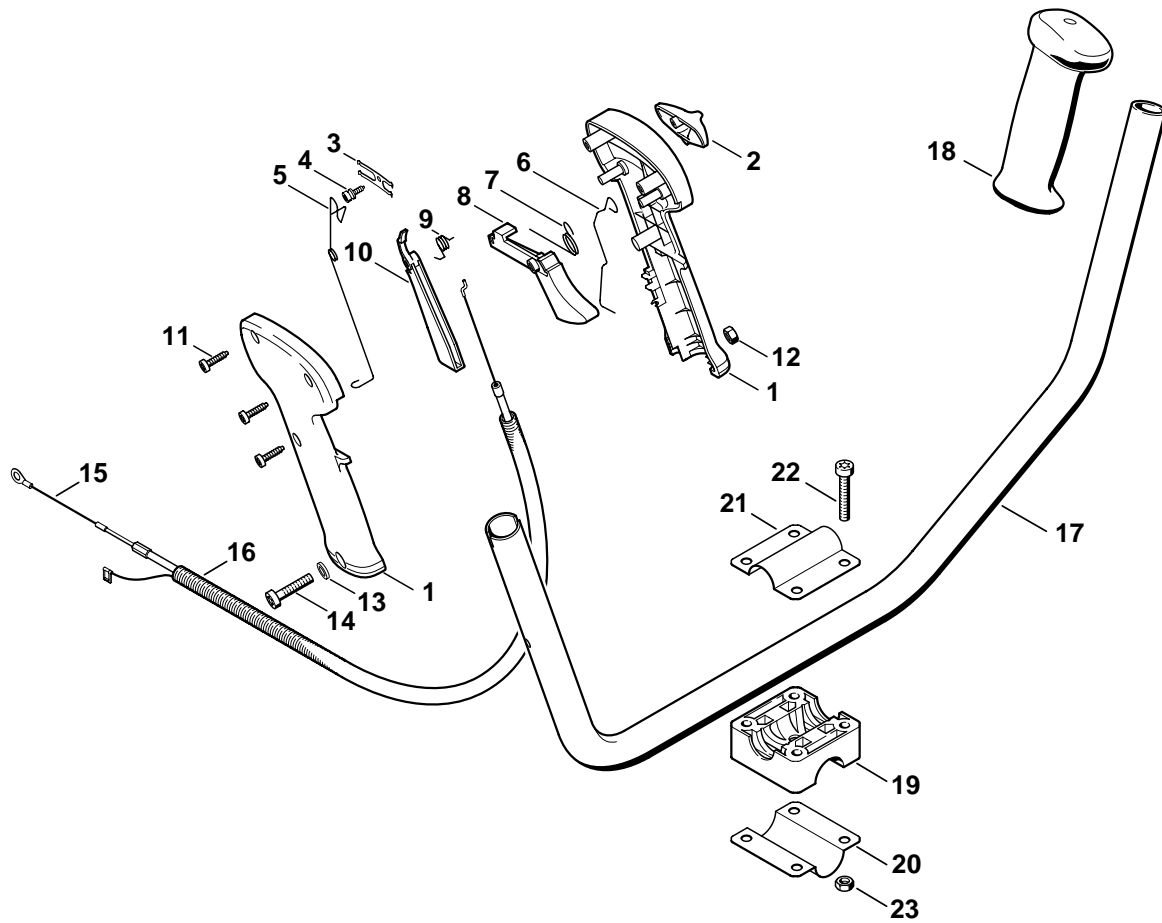

392ET071 SC

Illustration T

Zweihandgriff

Two-handed handle bar

Poignée tubulaire à deux mains

Bild-Nr.	Teile-Nr.	St-Zahl	Benennung	Part Name	Désignation
			(24.2002)	(24.2002)	(24.2002)
	* 4128 790 1300	1	Bedienungsgriff (2,4,6) □ 1 - 12, 14	Control handle (2,4,6) □ 1 - 12, 14	Poignée de commande (2,4,6) □ 1 - 12, 14
1 *	4128 790 0300	1	Handgriff rechts (2,4,6)	Handle, right (2,4,6)	Poignée droite (2,4,6)
2 *	4128 182 1700	1	Kombischieber (2,4,6)	Slide control (2,4,6)	Curseur combiné (2,4,6)
3 *	4128 182 4200	1	Rastfeder (2,4,6)	Detent spring (2,4,6)	Ressort d'encliquetage (2,4,6)
4 *	4128 182 6200	1	Bundschraube (2,4,6)	Collar screw (2,4,6)	Vis à embase (2,4,6)
5 *	4128 442 1600	1	Kontaktfeder (2,4,6)	Contact spring (2,4,6)	Ressort de connexion (2,4,6)
6 *	4128 442 1605	1	Kontaktfeder (2,4,6)	Contact spring (2,4,6)	Ressort de connexion (2,4,6)
7 *	4128 182 4500	1	Schenkelfeder (2,4,6)	Torsion spring (2,4,6)	Ressort coudé (2,4,6)
8 *	4128 182 1000	1	Gashebel (2,4,6)	Throttle trigger (2,4,6)	Manette des gaz (2,4,6)
9 *	4128 182 4501	1	Schenkelfeder (2,4,6)	Torsion spring (2,4,6)	Ressort coudé (2,4,6)
10 *	4128 182 0800	1	Sperrhebel (2,4,6)	Trigger interlock (2,4,6)	Levier d'arrêt (2,4,6)
11 *	9074 478 3025	3	Schraube IS-P4x16 (2,4,6)	Pan head self-tapping screw IS-P4x16 (2,4,6)	Vis cylindrique IS-P4x16 (2,4,6)
12 *	9214 320 0700	1	Sicherungsmutter DIN980-V M5-10 (2,4,6)	Lock nut M5 (2,4,6)	Ecrou de sécurité M5 (2,4,6)
13 *	9291 021 0120	1	Scheibe DIN125-A5,3 (2,4,6)	Washer 5.3 (2,4,6)	Rondelle 5,3 (2,4,6)
14 *	9022 346 1070	1	Schraube IS-M5x30x22-10.9 (2,4,6)	Spline screw IS-M5x30 (2,4,6)	Vis cylindrique IS-M5x30 (2,4,6)
15 *	4137 180 1100	1	Gaszug (2,4,6) □ 16	Throttle cable (2,4,6) □ 16	Câble de commande des gaz (2,4,6) □ 16
16 *		1	Schlauch 765 mm (2,4,6)	Hose 765mm / 30 1/8" (2,4,6)	Tuyau 765 mm (2,4,6)
	* 4203 711 7201	1	Schlauch 960 mm (A) (2,4,6)	Hose 960mm / 37 13/16" (A) (2,4,6)	Tuyau 960 mm (A) (2,4,6)
			(15.2003)	(15.2003)	(15.2003)
17 *	4137 790 1701	1	Griffrohr (2,4,6) □ 18	Handlebar (2,4,6) □ 18	Poignée tubulaire (2,4,6) □ 18
18 *	4128 791 0300	1	Handgriff links (2,4,6)	Handle, left (2,4,6)	Poignée gauche (2,4,6)
19 *	4137 791 6800	1	Klemmstück (2,4,6)	Clamp (2,4,6)	Pièce de serrage (2,4,6)
20 *	4130 791 0606	1	Klemmschale (2,4,6)	Clamp (2,4,6)	Monture de serrage (2,4,6)
21 *	4137 791 0900	1	Klemmschale (2,4,6)	Clamp (2,4,6)	Monture de serrage (2,4,6)
22 *	9022 341 1380	4	Schraube IS-M6x35-10.9 (2,4,6)	Spline screw IS-M6x35 (2,4,6)	Vis cylindrique IS-M6x35 (2,4,6)
23 *	9210 319 0900	4	Mutter DIN934-M6-10 (2,4,6)	Hexagon nut M6 (2,4,6)	Ecrou à six pans M6 (2,4,6)

(1) FS 75, (2) FS 80, (3) FS 80 R, (4) FS 85, (5) FS 85 R, (6) FS 85 T, (7) FS 85 RX

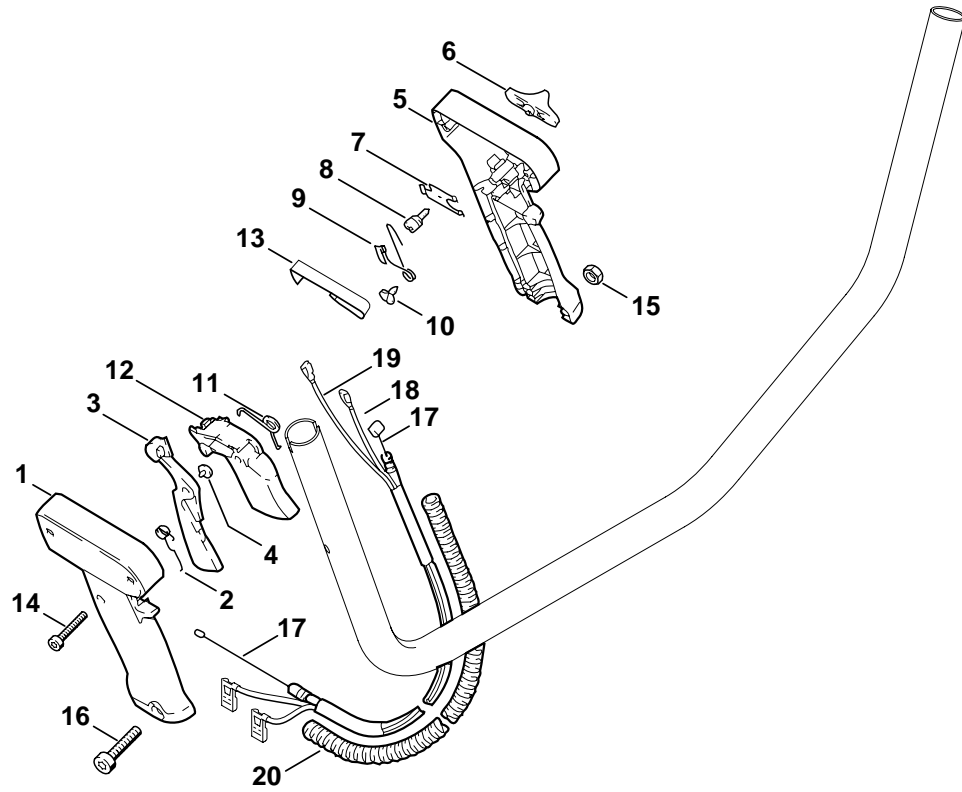

392ET063 GM

Illustration U

Zweihandgriff

Two-handed handle bar

Poignée tubulaire à deux mains

Bild-Nr.	Teile-Nr.	St-Zahl	Benennung	Part Name	Désignation
	* 4119 790 1302	1	Bedienungsgriff (2,4) □ 1 - 16	Control handle (2,4) □ 1 - 16	Poignée de commande (2,4) □ 1 - 16
1	* 4119 791 0801	1	Griffhälfte außen (2,4)	Handle molding, outer (2,4)	Monture de poignée extérieure (2,4)
2	* 4126 182 4506	1	Schenkelfeder (2,4)	Torsion spring (2,4)	Ressort coudé (2,4)
3	* 4126 182 0800	1	Sperrhebel (2,4)	Trigger interlock (2,4)	Levier d'arrêt (2,4)
4	* 4126 182 6210	1	Bundschraube (2,4)	Collar screw (2,4)	Vis à embase (2,4)
5	* 4119 791 0811	1	Griffhälfte innen (2,4)	Handle molding, inner (2,4)	Monture de poignée intérieure (2,4)
6	* 4126 182 1700	1	Kombischieber (2,4)	Slide control (2,4)	Curseur combiné (2,4)
7	* 4126 182 4700	1	Rastfeder (2,4)	Detent spring (2,4)	Ressort d'encliquetage (2,4)
8	* 4126 182 6200	1	Bundschraube (2,4)	Collar screw (2,4)	Vis à embase (2,4)
9	* 4126 442 1600	1	Kontaktfeder (2,4)	Contact spring (2,4)	Ressort de connexion (2,4)
10	* 4126 182 6210	1	Bundschraube (2,4)	Collar screw (2,4)	Vis à embase (2,4)
11	* 4126 182 4500	1	Schenkelfeder (2,4)	Torsion spring (2,4)	Ressort coudé (2,4)
12	* 4126 182 1001	1	Gashebel (2,4)	Throttle trigger (2,4)	Manette des gaz (2,4)
13	* 4126 442 1610	1	Kontaktfeder (2,4)	Contact spring (2,4)	Ressort de connexion (2,4)
14	* 9099 021 1890	5	Schraube DIN7971-2,9x25 (2,4)	Self-tapping screw 2.9x25 (2,4)	Vis Parker 2,9x25 (2,4)
15	* 9210 260 0700	2	Mutter DIN934-M5-8 (2,4)	Hexagon nut M5 (2,4)	Ecrou à six pans M5 (2,4)
16	* 9022 341 1070	2	Schraube IS-M5x30x22-10.9 (2,4)	Spline screw IS-M5x30 (2,4)	Vis cylindrique IS-M5x30 (2,4)
17	* 4133 180 1115	1	Gaszug (2,4)	Throttle cable (2,4)	Câble de commande des gaz (2,4)
18	*	1	Leitung 1010 mm (2,4)	Lead 1010mm / 40" (2,4)	Câble 1010 mm (2,4)
19	*	1	Leitung 1040 mm (2,4)	Lead 1040mm / 40.9" (2,4)	Câble 1040 mm (2,4)
	* 0751 010 1110	1	Leitung 10 m (A,B) (2,4)	Lead 10m / 33' (A,B) (2,4)	Conduit 10 m (A,B) (2,4)
20	*	1	Schlauch 765 mm (2,4)	Hose 765mm / 30 1/8" (2,4)	Tuyau 765 mm (2,4)
	* 4203 711 7201	1	Schlauch 960 mm (2,4)	Hose 960mm / 37 13/16" (2,4)	Tuyau 960 mm (2,4)

(1) FS 75, (2) FS 80, (3) FS 80 R, (4) FS 85, (5) FS 85 R, (6) FS 85 T, (7) FS 85 RX

Illustration V

Schaft FS 80, 80 R, 85,
85 R, 85 RX

Drive tube assembly FS 80,
80 R, 85, 85 R, 85 RX

Tube complet FS 80, 80 R,
85, 85 R, 85 RX

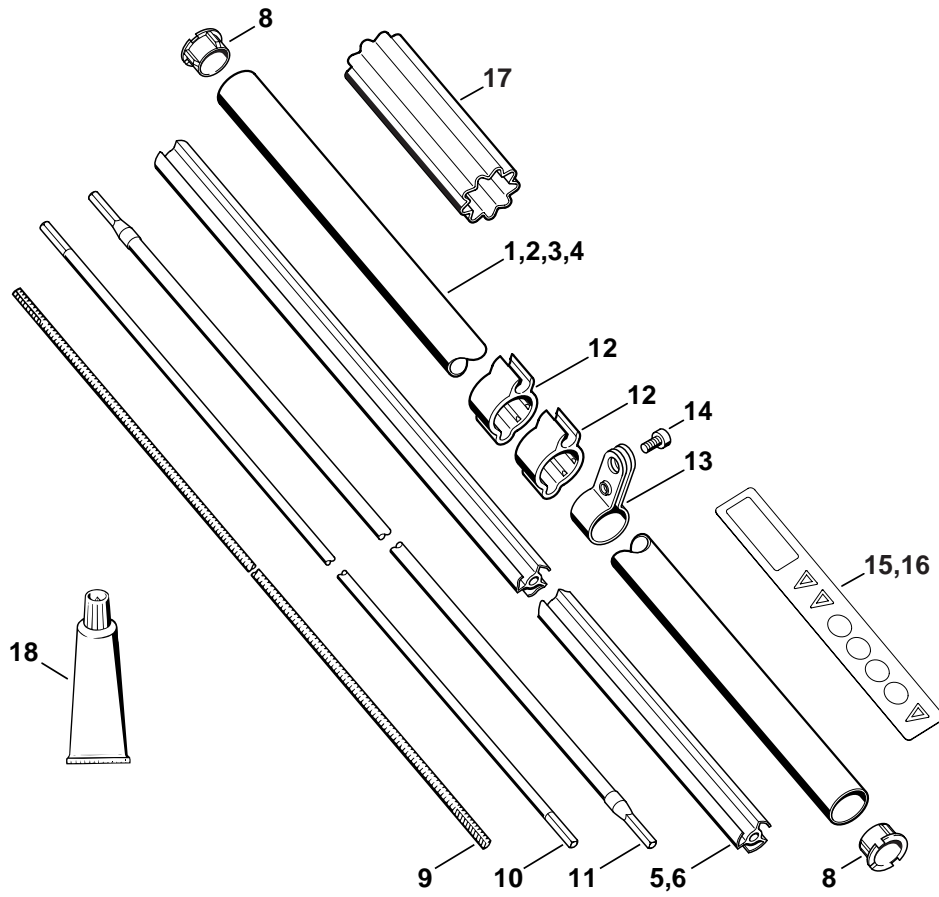

392ET060 GM

Illustration V

Schaft FS 80, 80 R, 85,
85 R, 85 RX

Drive tube assembly FS 80,
80 R, 85, 85 R, 85 RX

Tube complet FS 80, 80 R,
85, 85 R, 85 RX

Bild-Nr.	Teile-Nr.	St-Zahl	Benennung	Part Name	Désignation
1	4137 710 7108	1	Schaft Ø 25,4 mm (2,3,4,5) □ 5, 8, 15	Drive tube assembly Ø 25.4mm / 1" (2,3,4,5) □ 5, 8, 15	Tube complet Ø 25,4 mm (2,3,4,5) □ 5, 8, 15
2	4137 710 7100	1	Schaft Ø 25,4 mm USA (2,3,4,5) □ 5, 8, 16	Drive tube assembly Ø 25.4mm / 1" USA (2,3,4,5) □ 5, 8, 16	Tube complet Ø 25,4 mm USA (2,3,4,5) □ 5, 8, 16
3	4137 710 7132	1	Schaft Ø 25,4 mm (7) □ 6, 8, 15	Drive tube assembly Ø 25.4mm / 1" (7) □ 6, 8, 15	Tube complet Ø 25,4 mm (7) □ 6, 8, 15
4	4137 710 7118	1	Schaft Ø 25,4 mm USA (7) □ 6, 8, 16	Drive tube assembly Ø 25.4mm / 1" USA (7) □ 6, 8, 16	Tube complet Ø 25,4 mm USA (7) □ 6, 8, 16
5	4137 711 7300	1	Lagerrohr 1455 mm (2,3,4,5)	Flexible liner 1455mm / 57 5/16" (2,3,4,5)	Fourreau 1455 mm (2,3,4,5)
6	4134 711 7301	1	Lagerrohr 1440 mm (7)	Flexible liner 1440mm / 56 3/4" (7)	Fourreau 1440 mm (7)
8	4137 711 2101	2	Stopfen (2,3,4,5,7)	Plug (2,3,4,5,7)	Bouchon (2,3,4,5,7)
9	4137 711 3202	1	Antriebswelle (2,3)	Drive shaft (2,3)	Arbre d'entraînement (2,3)
10	4137 711 3200	1	Antriebswelle (4,5)	Drive shaft (4,5)	Arbre d'entraînement (4,5)
11	4137 710 3202	1	Antriebswelle (7)	Drive shaft (7)	Arbre d'entraînement (7)
12	4119 182 2110	2	Halter (2,3,4,5,7)	Support (2,3,4,5,7)	Crampon (2,3,4,5,7)
13	4140 007 1006	1	Satz Spannschelle (2,3,4,5,7) □ 14	Hose clamp kit (2,3,4,5,7) □ 14	Jeu de collier de serrage (2,3,4,5,7) □ 14
14	9022 341 1270	1	Schraube IS-M6x14-10.9 (2,3,4,5,7)	Spline screw IS-M6x14 (2,3,4,5,7)	Vis cylindrique IS-M6x14 (2,3,4,5,7)
15	0000 967 3725	1	Warnhinweis Piktogramm FS (2,3,4,5,7)	Warning pictogram FS (2,3,4,5,7)	Pictogramme d'avertissement FS (2,3,4,5,7)
16	0000 967 3684	1	Warnhinweis Piktogramm FS USA (2,3,4,5,7)	Warning pictogram FS USA (2,3,4,5,7)	Pictogramme d'avertissement FS USA (2,3,4,5,7)
17	0000 711 2500	1	Hülse (2,3,4,5,7)	Sleeve (2,3,4,5,7)	Douille (2,3,4,5,7)
18	0781 120 1110	1	Getriebefett (B) (2,3,4,5,7)	Gear lubricant (B) (2,3,4,5,7)	Graisse de réducteur (B) (2,3,4,5,7)

(1) FS 75, (2) FS 80, (3) FS 80 R, (4) FS 85, (5) FS 85 R, (6) FS 85 T, (7) FS 85 RX

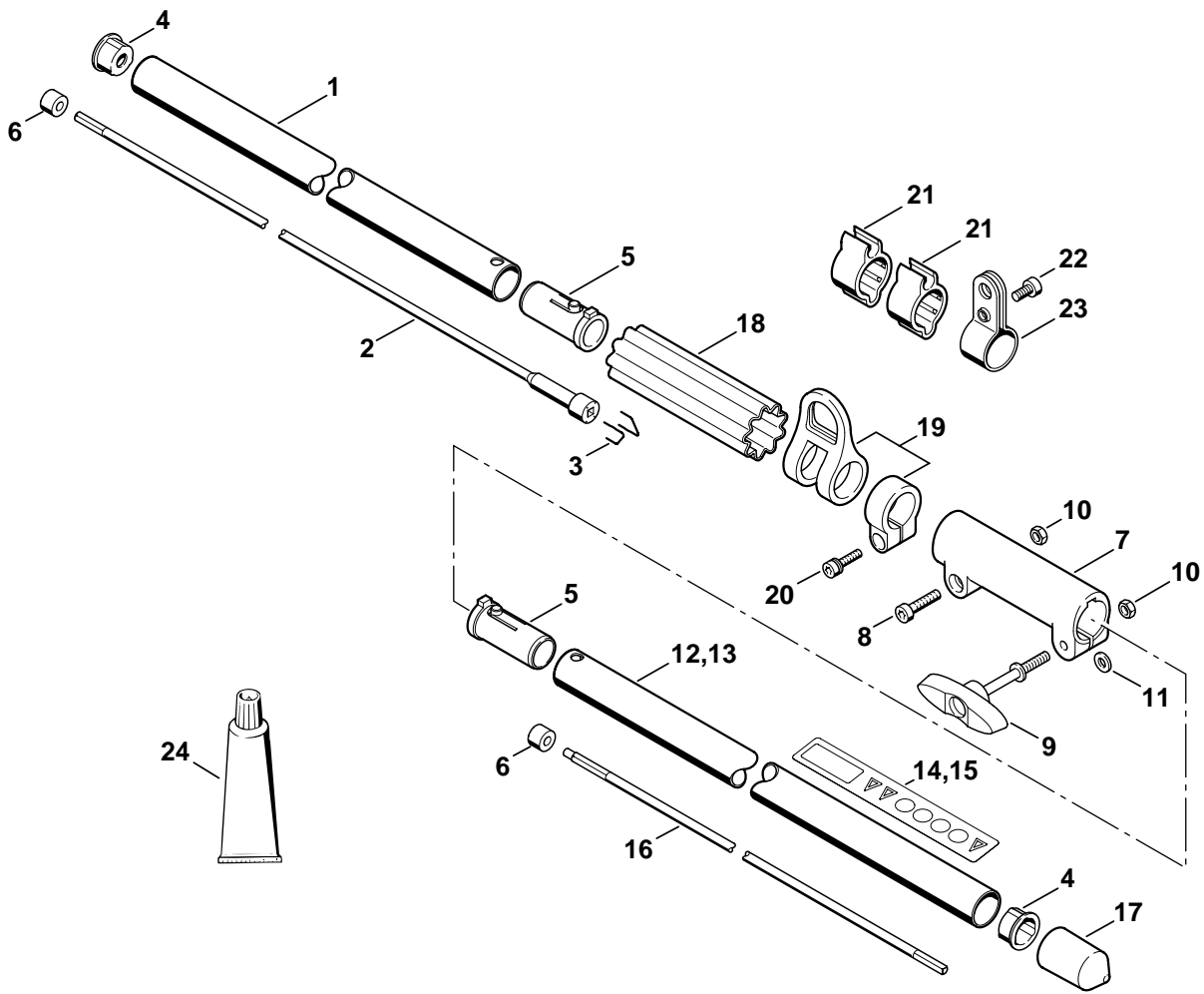

392ET057 GM

Illustration W

Schaft FS 85 T

Drive tube assembly
FS 85 T

Tube complet FS 85 T

Bild-Nr.	Teile-Nr.	St-Zahl	Benennung	Part Name	Désignation
			(14.2002)	(14.2002)	(14.2002)
1 *	4140 710 7120	1	Schaft Ø 25,4 mm (7) □ 4	Drive tube assembly Ø 25.4mm / 1" (7) □ 4	Tube complet Ø 25,4 mm (7) □ 4
2 *	4140 710 3220	1	Antriebswelle (7) □ 3, 5, 6	Drive shaft (7) □ 3, 5, 6	Arbre d'entraînement (7) □ 3, 5, 6
3 *	4140 716 2200	2	Bügel (7)	Bow (7)	Etrier (7)
4 *	4137 711 2101	2	Stopfen (7)	Plug (7)	Bouchon (7)
5 *	4140 791 7201	2	Hülse (7)	Sleeve (7)	Douille (7)
6 *	4140 711 2500	2	Hülse (7)	Sleeve (7)	Douille (7)
7 *	4140 160 0700	1	Kupplungsmuffe (7) □ 8 - 11	Coupling sleeve (7) □ 8 - 11	Manchon d'accouplement (7) □ 8 - 11
8 *	9022 341 1350	1	Schraube IS-M6x25-10.9 (7)	Spline screw IS-M6x25 (7)	Vis cylindrique IS-M6x25 (7)
9 *	4140 790 7500	1	Knebelschraube (7)	Tommy screw (7)	Vis à garrot (7)
10 *	9210 319 0900	2	Mutter DIN934-M6-10 (7)	Hexagon nut M6 (7)	Ecrou à six pans M6 (7)
11 *	9291 021 0140	1	Scheibe DIN125-A6,4 (7)	Washer 6.4 (7)	Rondelle 6,4 (7)
12 *	4140 710 7125	1	Schaft Ø 25,4 mm (7) □ 4, 14	Drive tube assembly Ø 25.4mm / 1" (7) □ 4, 14	Tube complet Ø 25,4 mm (7) □ 4, 14
13 *	4140 710 7126	1	Schaft Ø 25,4 mm USA (7) □ 4, 15	Drive tube assembly Ø 25.4mm / 1" USA (7) □ 4, 15	Tube complet Ø 25,4 mm USA (7) □ 4, 15
14 *	0000 967 3725	1	Warnhinweis Piktogramm FS (7)	Warning pictogram FS (7)	Pictogramme d'avertissement FS (7)
15 *	0000 967 3684	1	Warnhinweis Piktogramm FS USA (7)	Warning pictogram FS USA (7)	Pictogramme d'avertissement FS USA (7)
16 *	4140 710 3225	1	Antriebswelle (7) □ 6	Drive shaft (7) □ 6	Arbre d'entraînement (7) □ 6
17 *	4133 717 2000	1	Kappe (7)	Cap (7)	Chapeau de roue (7)
18 *	0000 711 2500	1	Hülse (7)	Sleeve (7)	Douille (7)
19 *	4230 790 8800	1	Tragöse (7) □ 20	Eye (7) □ 20	Oeillet de suspension (7) □ 20
20 *	0000 951 1104	1	Schraube IS-M5x22 (7)	Screw IS-M5x22 (7)	Vis cylindrique IS-M5x22 (7)
21 *	4119 182 2110	2	Halter (7)	Support (7)	Crampon (7)
22 *	4140 007 1006	1	Satz Spannschelle (7) □ 23	Hose clamp kit (7) □ 23	Jeu de collier de serrage (7) □ 23
23 *	9022 341 1270	1	Schraube IS-M6x14-10.9 (7)	Spline screw IS-M6x14 (7)	Vis cylindrique IS-M6x14 (7)
24 *	0781 120 1110	1	Getriebefett (B) (7)	Gear lubricant (B) (7)	Graisse de réducteur (B) (7)

(1) FS 75, (2) FS 80, (3) FS 80 R, (4) FS 85, (5) FS 85 R, (6) FS 85 T, (7) FS 85 RX

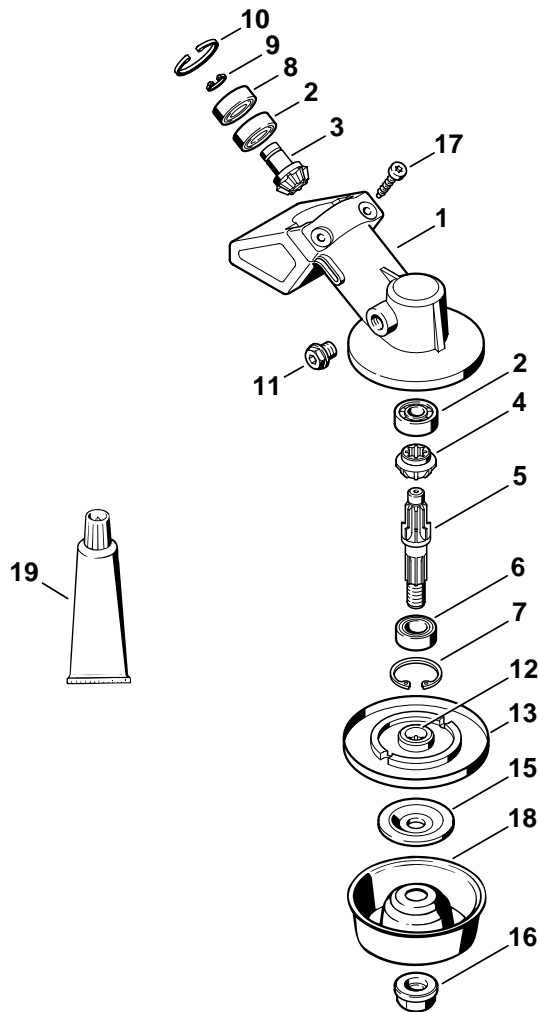

392ET032 GM

Illustration X

Getriebe FS 80, 80 R, 85,
85 R, 85 T, 85 RX

Gear head FS 80, 80 R, 85,
85 R, 85 T, 85 RX

Réducteur FS 80, 80 R, 85,
85 R, 85 T, 85 RX

Bild-Nr.	Teile-Nr.	St-Zahl	Benennung	Part Name	Désignation
	4137 640 0100	1	Getriebe (2,3,4,5,6,7) □ 1 - 17	Gear head (2,3,4,5,6,7) □ 1 - 17	Réducteur (2,3,4,5,6,7) □ 1 - 17
1	4130 641 0305	1	Getriebegehäuse (2,3,4,5,6,7)	Gear housing (2,3,4,5,6,7)	Carter de réducteur (2,3,4,5,6,7)
2	9503 003 9850	2	Kugellager DIN625-609 (2,3,4,5,6,7)	Grooved ball bearing 609 (2,3,4,5,6,7)	Roulement rainuré à billes 609 (2,3,4,5,6,7)
	4130 640 7301	1	Ritzelsatz (2,3,4,5,6,7) □ 3, 4	Set of pinions (2,3,4,5,6,7) □ 3, 4	Jeu de pignons (2,3,4,5,6,7) □ 3, 4
3		1	Antriebsritzel (D) (2,3,4,5,6,7)	Drive pinion (D) (2,3,4,5,6,7)	Pignon d'entraînement (D) (2,3,4,5,6,7)
4		1	Tellerrad (D) (2,3,4,5,6,7)	Spur bevel gear (D) (2,3,4,5,6,7)	Pignon denté (D) (2,3,4,5,6,7)
5	4130 642 0601	1	Abtriebswelle (2,3,4,5,6,7)	Drive shaft (2,3,4,5,6,7)	Arbre de sortie (2,3,4,5,6,7)
6	9503 003 5190	1	Kugellager DIN625-6001-2RS (2,3,4,5,6,7)	Grooved ball bearing 6001-2RS (2,3,4,5,6,7)	Roulement rainuré à billes 6001-2RS (2,3,4,5,6,7)
7	9456 621 3100	1	Sicherungsring DIN472-28x1,2 (2,3,4,5,6,7)	Circlip 28x1.2 (2,3,4,5,6,7)	Circlips 28x1,2 (2,3,4,5,6,7)
8	9503 003 9853	1	Kugellager DIN625-609-2Z (2,3,4,5,6,7)	Grooved ball bearing 609-2Z (2,3,4,5,6,7)	Roulement rainuré à billes 609-2Z (2,3,4,5,6,7)
9	9455 621 0750	1	Sicherungsring DIN471-9x1 (2,3,4,5,6,7)	Circlip 9x1 (2,3,4,5,6,7)	Circlips 9x1 (2,3,4,5,6,7)
10	9456 621 2660	1	Sicherungsring DIN472-24x1,2 (2,3,4,5,6,7)	Circlip 24x1.2 (2,3,4,5,6,7)	Circlips 24x1,2 (2,3,4,5,6,7)
11	4119 713 6500	1	Verschlusschraube (2,3,4,5,6,7)	Screw plug (2,3,4,5,6,7)	Bouchon fileté (2,3,4,5,6,7)
12	4137 710 3800	1	Druckteller (2,3,4,5,6,7) □ 13	Thrust plate (2,3,4,5,6,7) □ 13	Disque de pression (2,3,4,5,6,7) □ 13
13	4112 717 2801	1	Schutzscheibe (2,3,4,5,6,7)	Guard washer (2,3,4,5,6,7)	Rondelle de protection (2,3,4,5,6,7)
15	4130 713 1600	1	Druckscheibe (2,3,4,5,6,7)	Thrust washer (2,3,4,5,6,7)	Rondelle de pression (2,3,4,5,6,7)
16	4126 642 7600	1	Bundsicher Mutter M10x1 links (2,3,4,5,6,7)	Collar nut M10x1 l/h thread (2,3,4,5,6,7)	Ecrou à embase M10x1 à gauche (2,3,4,5,6,7)
17	9075 478 4159	2	Schraube IS-D5x24 (2,3,4,5,6,7)	Pan head self-tapping screw IS-D5x24 (2,3,4,5,6,7)	Vis cylindrique IS-D5x24 (2,3,4,5,6,7)
18	4126 713 3100	1	Lauffteller (2,3,4,5,6,7)	Rider plate (2,3,4,5,6,7)	Disque porteur (2,3,4,5,6,7)
19	0781 120 1117	1	Getriebefett (B) (2,3,4,5,6,7)	Gear lubricant (B) (2,3,4,5,6,7)	Graisse de réducteur (B) (2,3,4,5,6,7)

(1) FS 75, (2) FS 80, (3) FS 80 R, (4) FS 85, (5) FS 85 R, (6) FS 85 T, (7) FS 85 RX

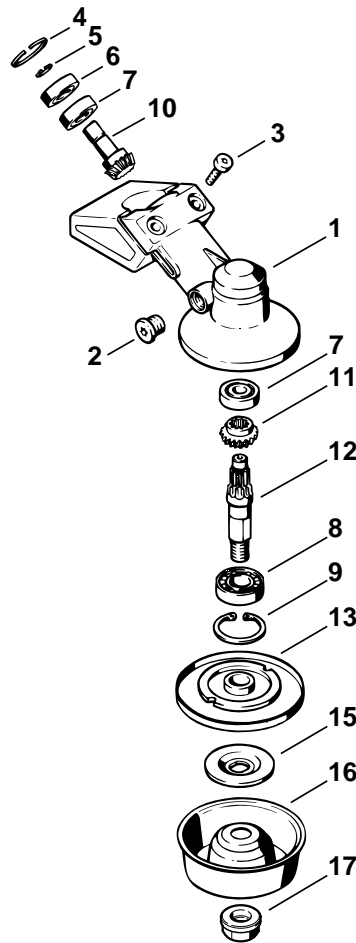

342ET018 SC

Illustration Y

Getriebe FS 80, 80 R, 85,
85 R

Gear head FS 80, 80 R, 85,
85 R

Réducteur FS 80, 80 R, 85,
85 R

Bild-Nr.	Teile-Nr.	St-Zahl	Benennung	Part Name	Désignation
			➔ X 35 221 993 (32.97)	➔ X 35 221 993 (32.97)	➔ X 35 221 993 (32.97)
	* 4130 640 0100	1	Getriebe (C) (2,3,4,5) □ 1 - 12	Gear head (C) (2,3,4,5) □ 1 - 12	Réducteur (C) (2,3,4,5) □ 1 - 12
1 *	4130 641 0300	1	Getriebegehäuse (2,3,4,5)	Gear housing (2,3,4,5)	Carter de réducteur (2,3,4,5)
2 *	4119 713 6500	1	Verschlussschraube (2,3,4,5)	Screw plug (2,3,4,5)	Bouchon fileté (2,3,4,5)
3 *	9022 371 1020	2	Schraube IS-M5x20-12.9 (2,3,4,5)	Spline screw IS-M5x20 (2,3,4,5)	Vis cylindrique IS-M5x20 (2,3,4,5)
4 *	9456 621 2440	1	Sicherungsring DIN472-22x1 (2,3,4,5)	Circlip 22x1 (2,3,4,5)	Circlips 22x1 (2,3,4,5)
5 *	9452 600 0750	1	Sicherungsring 9,525x0,8 (2,3,4,5)	Circlip 9.5x0.8 (2,3,4,5)	Circlips 9,5x0,8 (2,3,4,5)
6 *	9507 003 8056	1	Kugellager 9,5x22,2x7,14 (2,3,4,5)	Grooved ball bearing 9.5x22.2x7.14 (2,3,4,5)	Roulement rainuré à billes 9,5x22,2x7,14 (2,3,4,5)
7 *	9507 003 8054	2	Kugellager 9,5x22,2x7,14 (2,3,4,5)	Grooved ball bearing 9.5x22.2x7.14 (2,3,4,5)	Roulement rainuré à billes 9,5x22,2x7,14 (2,3,4,5)
8 *	9503 003 5190	1	Kugellager DIN625-6001-2RS (2,3,4,5)	Grooved ball bearing 6001-2RS (2,3,4,5)	Roulement rainuré à billes 6001-2RS (2,3,4,5)
9 *	9456 621 3100	1	Sicherungsring DIN472-28x1,2 (2,3,4,5)	Circlip 28x1.2 (2,3,4,5)	Circlips 28x1,2 (2,3,4,5)
	* 4130 640 7300	1	Ritzelsatz (2,3,4,5) □ 10, 11	Set of pinions (2,3,4,5) □ 10, 11	Jeu de pignons (2,3,4,5) □ 10, 11
10 *		1	Antriebsritzel (D) (2,3,4,5)	Drive pinion (D) (2,3,4,5)	Pignon d'entraînement (D) (2,3,4,5)
11 *		1	Tellerrad (D) (2,3,4,5)	Spur bevel gear (D) (2,3,4,5)	Pignon denté (D) (2,3,4,5)
12 *	4130 642 0610	1	Abtriebswelle (2,3,4,5)	Drive shaft (2,3,4,5)	Arbre de sortie (2,3,4,5)
13 *	4126 710 3800	1	Druckteller (2,3,4,5)	Thrust plate (2,3,4,5)	Disque de pression (2,3,4,5)
15 *	4126 713 1600	1	Druckscheibe (2,3,4,5)	Thrust washer (2,3,4,5)	Rondelle de pression (2,3,4,5)
16 *	4126 713 3100	1	Laufsteller (2,3,4,5)	Rider plate (2,3,4,5)	Disque porteur (2,3,4,5)
17 *	4126 642 7600	1	Bundsicherungsmutter M10x1 links (2,3,4,5)	Collar nut M10x1 l/h thread (2,3,4,5)	Ecrou à embase M10x1 à gauche (2,3,4,5)
	* 0781 120 1117	1	Getriebefett (A,B) (2,3,4,5)	Gear lubricant (A,B) (2,3,4,5)	Graisse de réducteur (A,B) (2,3,4,5)

(1) FS 75, (2) FS 80, (3) FS 80 R, (4) FS 85, (5) FS 85 R, (6) FS 85 T, (7) FS 85 RX

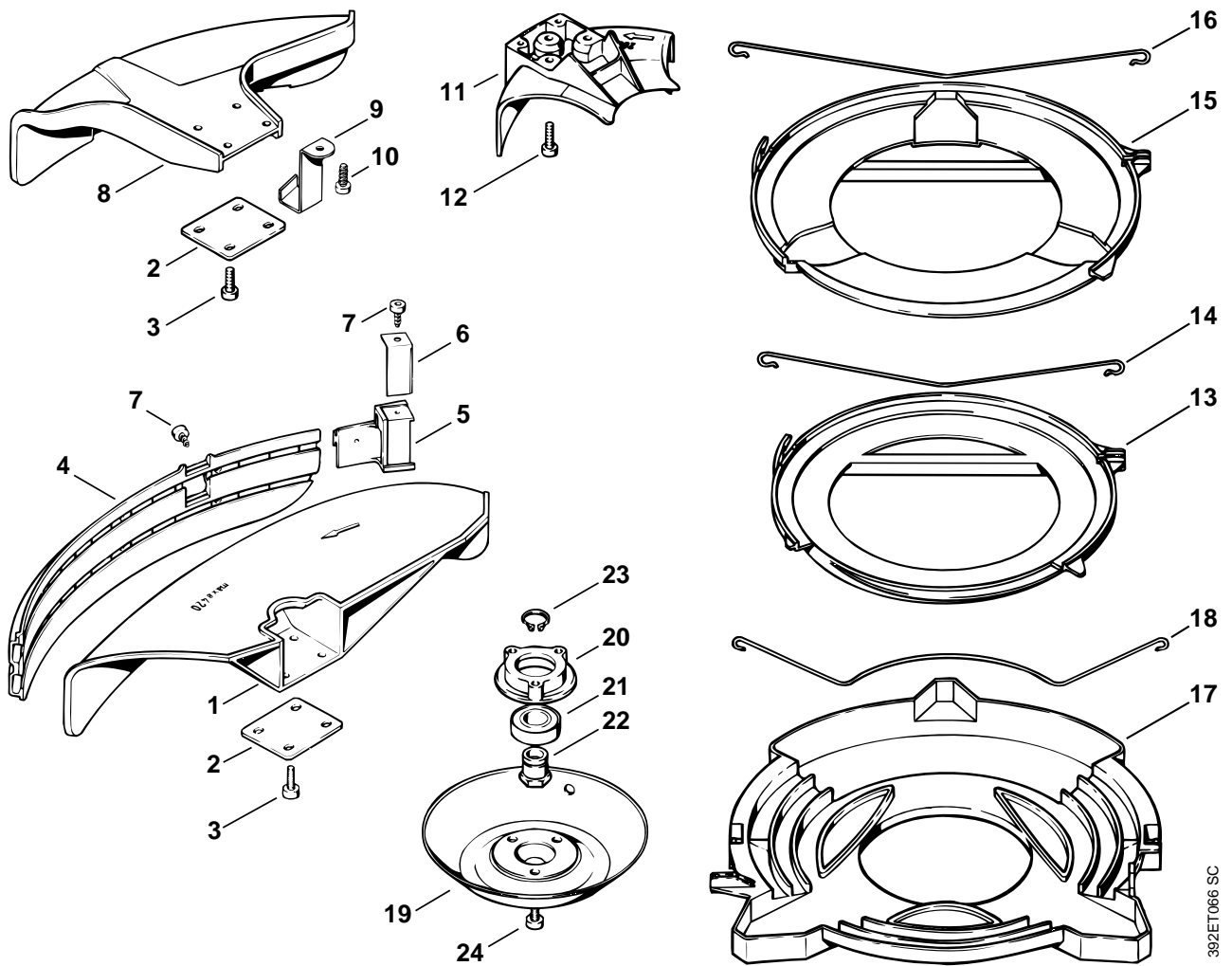

392ET066 SC

Illustration Z

Schutz

Deflector

Capot protecteur

Bild-Nr.	Teile-Nr.	St-Zahl	Benennung	Part Name	Désignation
	4119 007 1013	1	Satz Schutz (2,3,4,5,6,7) □ 1 - 7	Deflector kit (2,3,4,5,6,7) □ 1 - 7	Jeu de pièces de capot protecteur (2,3,4,5,6,7) □ 1 - 7
1	4119 713 4500	1	Schutz (2,3,4,5,6,7)	Deflector (2,3,4,5,6,7)	Capot protecteur (2,3,4,5,6,7)
2	4112 716 3100	1	Unterlage (2,3,4,5,6,7)	Backing plate (2,3,4,5,6,7)	Cale (2,3,4,5,6,7)
3	9022 341 0980	4	Schraube IS-M5x16-12.9 (2,3,4,5,6,7)	Spline screw IS-M5x16 (2,3,4,5,6,7)	Vis cylindrique IS-M5x16 (2,3,4,5,6,7)
4	4119 716 3200	1	Schürze (2,3,4,5,6,7)	Skirt (2,3,4,5,6,7)	Tablier (2,3,4,5,6,7)
5	4119 710 6000	1	Ablängmesser (2,3,4,5,6,7) □ 6, 7	Blade (2,3,4,5,6,7) □ 6, 7	Couteau (2,3,4,5,6,7) □ 6, 7
6	4118 713 4105	1	Ablängmesser (2,3,4,5,6,7)	Blade (2,3,4,5,6,7)	Couteau (2,3,4,5,6,7)
7	9074 478 4125	2	Schraube IS-5x14 (2,3,4,5,6,7)	Pan head self-tapping screw IS-5x14 (2,3,4,5,6,7)	Vis cylindrique IS 5x14 (2,3,4,5,6,7)
8	4133 007 1002	1	Satz Schutz (2,3,4,5,6,7) □ 2, 3, 9, 10	Deflector kit (2,3,4,5,6,7) □ 2, 3, 9, 10	Jeu de capot protecteur (2,3,4,5,6,7) □ 2, 3, 9, 10
9	4133 713 4110	1	Ablängmesser (2,3,4,5,6,7)	Blade (2,3,4,5,6,7)	Couteau (2,3,4,5,6,7)
10	9074 478 4405	2	Schraube IS-P6x14 (2,3,4,5,6,7)	Pan head self-tapping screw IS-P6x14 (2,3,4,5,6,7)	Vis cylindrique IS-P6x14 (2,3,4,5,6,7)
11	4117 710 8200	1	Anschlag Ø 200 (2,4,6) □ 12	Limit stop Ø 200 (2,4,6) □ 12	Butée Ø 200 (2,4,6) □ 12
12	9022 341 1010	3	Schraube IS-M5x18-10.9 (2,4,6)	Spline screw IS-M5x18 (2,4,6)	Vis cylindrique IS-M5x18 (2,4,6)
13	4119 790 3901	1	Transportschutz Ø 225 (2,4,6) □ 14	Transport guard Ø 225 (2,4,6) □ 14	Protecteur de transport Ø 225 (2,4,6) □ 14
14	4119 792 4300	1	Spannbügel (2,4,6)	Clamping wire (2,4,6)	Bride de fixation (2,4,6)
15	4119 790 3906	1	Transportschutz Ø 255 (2,4,6) □ 16	Transport guard Ø 255 (2,4,6) □ 16	Protecteur de transport Ø 255 (2,4,6) □ 16
16	4119 792 4305	1	Spannbügel (2,4,6)	Clamping wire (2,4,6)	Bride de fixation (2,4,6)
17	4116 790 3901	1	Transportschutz (2,4,6) □ 18	Transport guard (2,4,6) □ 18	Protecteur de transport (2,4,6) □ 18
18	4116 792 4300	1	Spannbügel (2,4,6)	Clamping wire (2,4,6)	Bride de fixation (2,4,6)
			Sonderzubehör:	Extras:	Accessoires optionnel:
	4132 710 8500	1	Lauffeller (2,4,6) □ 19 - 24	Rider plate (2,4,6) □ 19 - 24	Disque porteur (2,4,6) □ 19 - 24
19	4112 713 3100	1	Lauffeller (2,4,6)	Rider plate (2,4,6)	Disque porteur (2,4,6)
20	4132 713 1400	1	Lagerdeckel (2,4,6)	Bearing cover (2,4,6)	Couvercle de roulement (2,4,6)
21	9503 003 5330	1	Kugellager DIN625-6003-2RS (2,4,6)	Grooved ball bearing 6003-2RS (2,4,6)	Roulement rainuré à billes 6003-2RS (2,4,6)
22	4132 713 6800	1	Bundmutter (2,4,6)	Collar nut (2,4,6)	Ecrou à embase (2,4,6)
23	9455 621 1800	1	Sicherungsring DIN471-17x1 (2,4,6)	Circlip 17x1 (2,4,6)	Circlips 17x1 (2,4,6)

(1) FS 75, (2) FS 80, (3) FS 80 R, (4) FS 85, (5) FS 85 R, (6) FS 85 T, (7) FS 85 RX

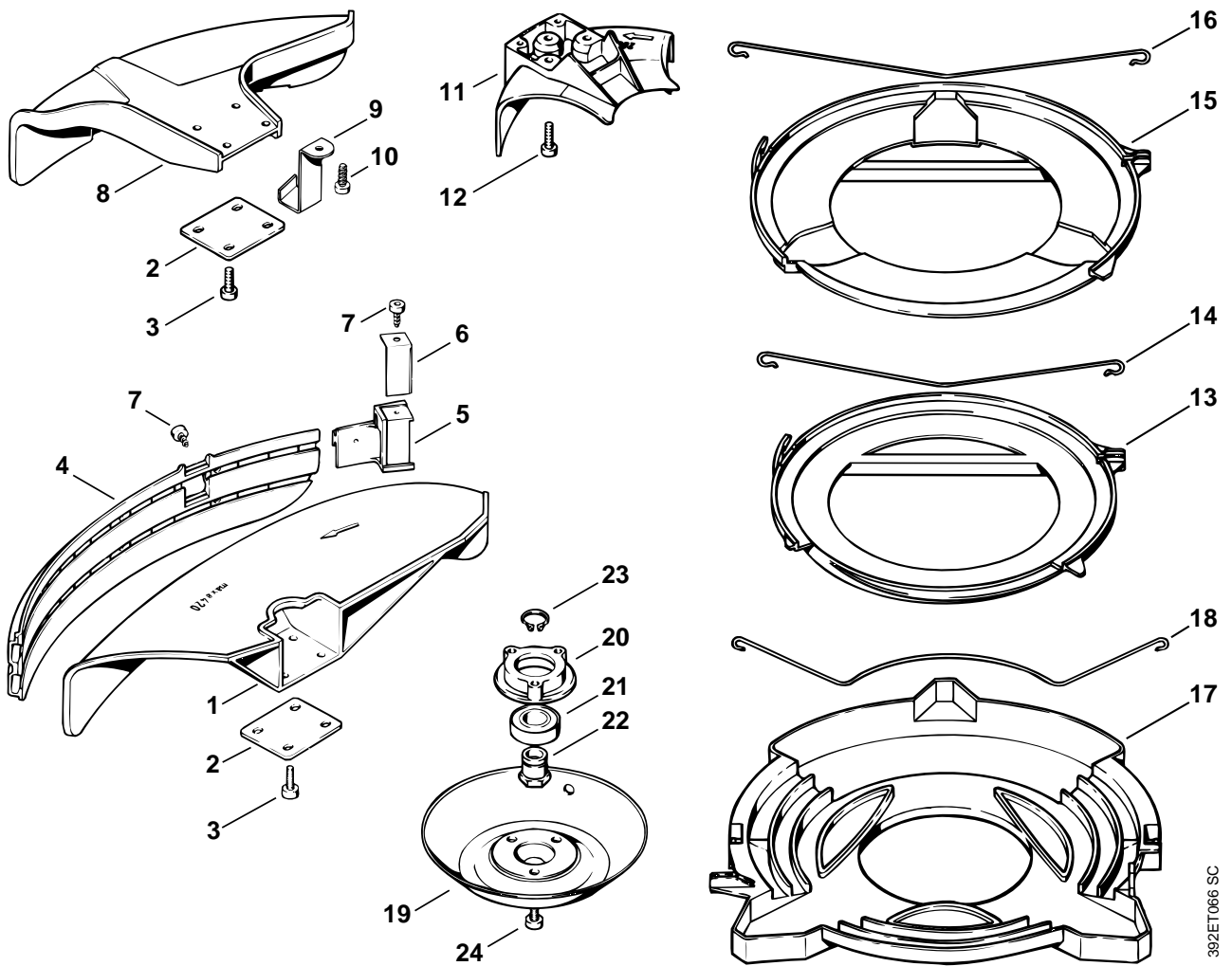

392ET066 SC

Bild-Nr.	Teile-Nr.	St-Zahl	Benennung	Part Name	Désignation
24	9022 341 1270	3	Schraube IS-M6x14-10.9 (2,4,6)	Spline screw IS-M6x14 (2,4,6)	Vis cylindrique IS-M6x14 (2,4,6)

(1) FS 75, (2) FS 80, (3) FS 80 R, (4) FS 85, (5) FS 85 R, (6) FS 85 T, (7) FS 85 RX

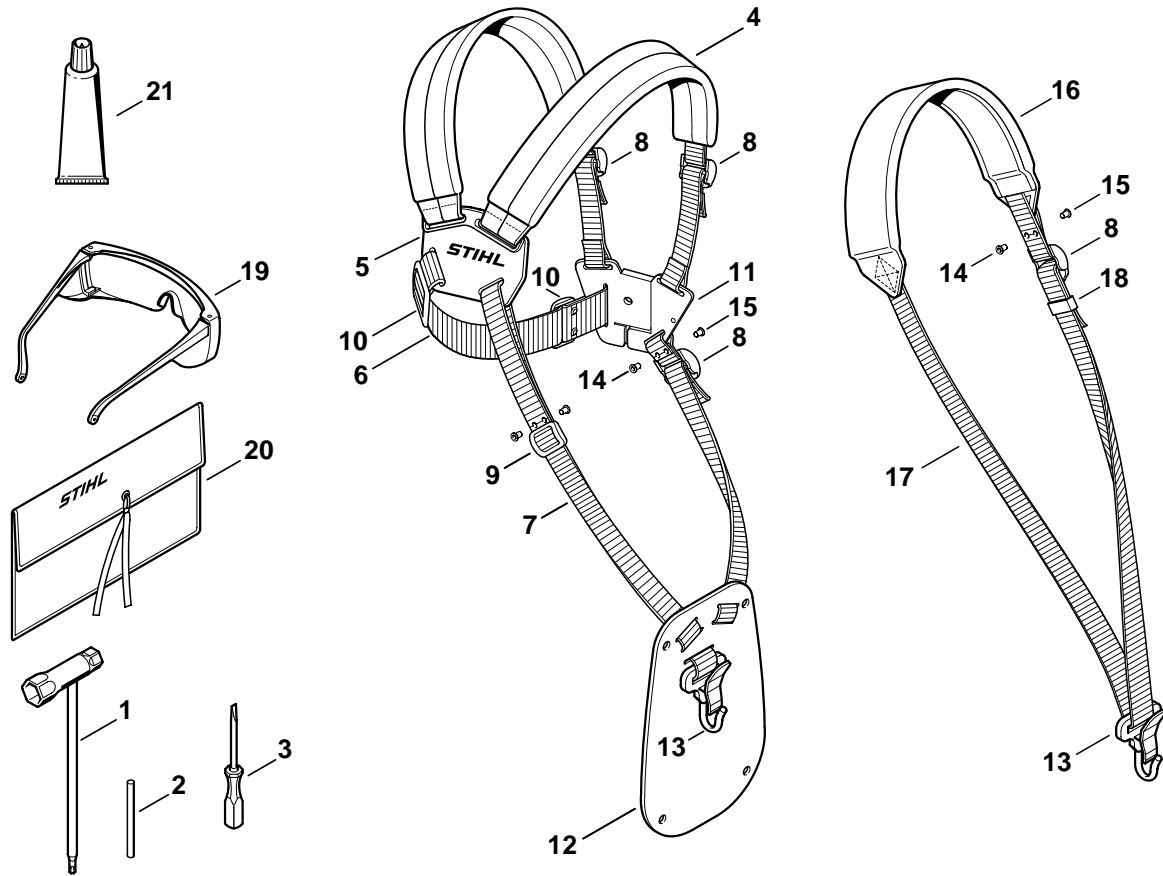

250ET032 GM

Illustration AA

Werkzeuge, Sonderzubehör

Tools, Extras

Outils, Accessoires optionnels

Bild-Nr.	Teile-Nr.	St-Zahl	Benennung	Part Name	Désignation
1	4128 890 3400	1	Kombischlüssel	Combination wrench	Clé multiple
2	4130 893 7800	1	Steckdorn	Locking pin	Mandrin
3	0000 890 2300	1	Schraubendreher	Screwdriver	Tournevis
3	0000 890 2305	1	Schraubendreher nur in Brasilien erhältlich	Screwdriver available in Brazil only	Tournevis seulement livrable au Brésil
4	4119 710 9001	1	Doppelschultergurt □ 5 - 13	Full harness □ 5 - 13	Harnais □ 5 - 13
5	4119 710 6306	1	Rückenplatte mit Riemen	Backplate with strap	Plaque dorsale avec sangle
6		1	Riemen 38x680 mm	Strap 38x680mm / 1.5x26.8"	Sangle 38x680 mm
	0000 930 2242	1	Gurtband 38 mm x 5 m (A,B)	Webbing 38mm x 5m / 1.5x197" (A,B)	Sangle 38 mm x 5 m (A,B)
7		1	Riemen 25 mm x 1 m	Strap 25mm x 1m / 1x40"	Sangle 25 mm x 1 m
	0000 930 2241	1	Gurtband 25 mm x 10 m (A,B)	Webbing 25mm x 10m / 1" x 33' (A,B)	Sangle 25 mm x 10 m (A,B)
8	4203 792 7200	3	Klemmschieber	Slide	Boucle de réglage
9	4119 718 6300	1	Schieber	Slide	Boucle de réglage
10	4119 718 6310	2	Schieber	Slide	Boucle de réglage
11	4119 710 6406	1	Schloss mit Riemen	Buckle with strap	Fermeture avec sangle
12	4119 718 7400	1	Schutzplatte	Guard plate	Plaque de protection
13	4119 710 6906	1	Karabinerhaken	Spring safety hock	Mousqueton
14	9408 021 4530		Nietteil DIN7331-AN4x8x6 (Stückzahl nach Bedarf)	Rivet shank 4x8x6 (quantity as required)	Rivet, partie à riveter 4x8x6 (quantité suivant besoin)
15	9409 021 4420		Kopfteil DIN7331-K4x8 (Stückzahl nach Bedarf)	Rivet head 4x8 (quantity as required)	Rivet, partie tête 4x8 (quantité suivant besoin)
16	4119 710 9011	1	Traggurt □ 8, 13, 17, 18	Harness □ 8, 13, 17, 18	Harnais □ 8, 13, 17, 18
17		1	Riemen 25 mm x 1,86 m	Strap 25mm x 1.86m / 1x73"	Sangle 25 mm x 1,86 m
18	4119 718 6320	1	Schieber	Slide	Boucle de réglage
19	0000 884 0307	1	Schutzbrille	Safety glasses	Lunettes de protection
20	0000 891 0801	1	Werkzeugtasche (B)	Tool roll (B)	Pochette à outils (B)
21	0783 830 2000	1	Dichtungsmasse Dirko HT rot (B)	Tube of sealant Dirko HT red (B)	Tube de pâte d'étanchéité Dirko HT rouge (B)

(1) FS 75, (2) FS 80, (3) FS 80 R, (4) FS 85, (5) FS 85 R, (6) FS 85 T, (7) FS 85 RX

- D** **Zeichenerklärung**
 = darin enthalten Bild-Nr
 * = Maschine älterer Bauart
 (A) = nicht abgebildet
 (B) = nur Sonderzubehör
 (C) = ab Werk nicht mehr lieferbar
 (D) = einzeln kein Ersatzteil
 (1,2,...) = Ausführungsarten
- E** **Aclaración de símbolos**
 = contiene núm. de ilustración
 * = máquinas de ejecución anterior
 (A) = sin ilustración
 (B) = sólo accesorios especiales
 (C) = ya no se suministra de fábrica
 (D) = la pieza suelta no se suministra como repuesto
 (1,2,...) = clases de ejecución
- FR** **Merkkien selitys**
 = johon sisältyvät kuvan numerot
 * = vanhemmanmalliset koneet
 (A) = ei kuvassa
 (B) = ainoastaan lisävaruste
 (C) = ei toimiteta enää tehtaalta
 (D) = ei toimiteta erikseen
 (1,2,...) = Mallit
- N** **Tegnforklaring**
 = medfølger fig. nr
 * = Maskiner av eldre modell
 (A) = ikke avbildet
 (B) = bare ekstrautstyr
 (C) = leveres ikke lenger fra fabrikk
 (D) = enkeltdele leveres ikke som reservedel
 (1,2,...) = utførelser
- P** **Explicação dos símbolos**
 = Incl. a fig. No.
 * = Máquinas de construção mais antiga
 (A) = não ilustrado
 (B) = unicamente acessórios especiais
 (C) = já não fornecível ex-fábrica
 (D) = a peça individual não é nenhuma peça de reposição
 (1,2,...) = Configurações
- TR** **İşaret açıklaması**
 = İndeks numarada dahildir
 * = Eski model makinalar
 (A) = Şemada yoktur
 (B) = Ekstradır
 (C) = Fabrikadan artık temin edilmez
 (D) = Ayırı verilmaz
 (1,2,...) = Mevcut modeller
- BR** **Explicação dos símbolos**
 = inclusive fig. n.
 * = máquinas antigas
 (A) = não ilustrado
 (B) = somente acessórios especiais
 (C) = não mais fornecido pela fábrica
 (D) = não fornecida separadamente
 (1,2,...) = diferentes versões
- DE** **Key to symbols**
 = including item No.
 * = previous Models
 (A) = not illustrated
 (B) = option
 (C) = no longer available from factory
 (D) = not available as separate item
 (1,2,...) = versions available
- HR** **Tumač znakova**
 = u istom sadrži dijelove, slike br.
 * = strojevi starije izvedbe
 (A) = nedostaje slika
 (B) = samo kao poseban pribor
 (C) = više se ne isporučuje fco tvornica
 (D) = ne isporučuje se pojedinačno kao pričuvni dio
 (1,2,...) = vrste izvedbi
- I** **Leggenda**
 = comprendente fig(g). n.
 * = Macchine di costruzione anteriore
 (A) = non illustrato
 (B) = fornibile soltanto a richiesta
 (C) = non più fornibile dallo stabilimento
 (D) = niente ricambio
 (1,2,...) = versioni
- CZ** **Vysvětlivky**
 = obsahuje obr. č.
 * = stroje starší konstrukce
 (A) = není vyobrazeno
 (B) = jen zvláštní příslušenství
 (C) = ze závodu se již nedodává
 (D) = jednotlivě žádný náhradní díl
 (1,2,...) = druhy provedení
- NL** **Toelichting symbolen**
 = daarin begrepen pos.nr.
 * = machines van een oudere uitvoering
 (A) = niet afgebeeld
 (B) = uitsluitend speciaal toebehoren
 (C) = af fabriek niet meer leverbaar
 (D) = niet los leverbaar
 (1,2,...) = uitvoeringen
- PL** **Objaśnienie znaków**
 = zawiera rysunki nr.
 * = maszyny starszego typu budowy
 (A) = nie zilustrowano
 (B) = tylko jako wyposażenie specjalne
 (C) = nie dostarczane przez producenta
 (D) = nie występuje jako samodzielna część zamienna
 (1,2,...) = rodzaj wykonania
- RO** **Legendă**
 = include figura nr.
 * = Utilaje de fabricație mai veche
 (A) = neilustrat
 (B) = doar ca accesoriu opțional
 (C) = nu se mai livrează din fabrică
 (D) = fără piesă de schimb separată
 (1,2,...) = diferite modele
- F** **Légende**
 = y compris Fig. No.
 * = machines d'ancienne construction
 (A) = non illustré
 (B) = uniquement accessoire optionnel
 (C) = n'est plus livrable départ usine
 (D) = n'est pas livrable séparément
 (1,2,...) = différentes exécutions
- S** **Teckenförklaring**
 = ingår bild-nr
 * = maskiner av tidigare utförande
 (A) = ej avbildat
 (B) = endast tillbehör
 (C) = levereras inte längre från fabriken
 (D) = ingen separat reservdel
 (1,2,...) = varianter
- DK** **Symbolforklaring**
 = inklusive fig. nr.
 * = maskiner af ældre konstruktion
 (A) = ikke afbilledet
 (B) = kun ekstratilbehør
 (C) = leveres ikke mere fra fabrik
 (D) = leveres ikke som løs reservedel
 (1,2,...) = modelbetegnelser
- H** **Jelmagyarázat**
 = abban tartalmazott ábra-szám
 * = Régebbi építéssorozatú gépek
 (A) = Nincs ábrázolva
 (B) = Csak külön tartozék
 (C) = Gyár már nem szállítja
 (D) = nem alkatrész, egyenként
 (1,2,...) = Kivitelezési módok
- GR** **Επεξήγηση συμβόλων**
 = περιλαμβάνει τον αριθμό του είδους
 * = Μηχανήματα παλαιότερων μοντέλων
 (A) = δεν απεικονίζεται
 (B) = μόνο προαιρετικά είδη
 (C) = δεν διατίθεται από τον κατασκευαστή
 (D) = δεν παραδίδεται ως ξεχωριστό είδος
 (1,2,...) = διαφορετικοί τύποι που διατίθενται
- RUS** **Пояснения к условным обозначениям**
 = сюда входят номера позиций
 * = машины более старого типа
 (A) = конструкции
 (B) = не изображено на иллюстрации
 (C) = только в виде специальных принадлежностей
 (D) = заводом больше не выпускается
 (1,2,...) = запасная деталь
 = Виды исполнений
- UAE** **زومرلا حرش**
 = ةروض مقرر كل ع يوتحت
 * = مري دق زارط نم تانديك ام
 (A) = ةروض مري غ
 (B) = طقف ةصاخ تامزلتسم
 (C) = ع نم ديروت ل ل ةلباق ري غ
 (D) = ه درف مري اي غ ةعطق ك سي ل
 = تازارط لا عاونا (...2,1)