

# ***WATER PUMP***

WT40X

**PARTS CATALOGUE**

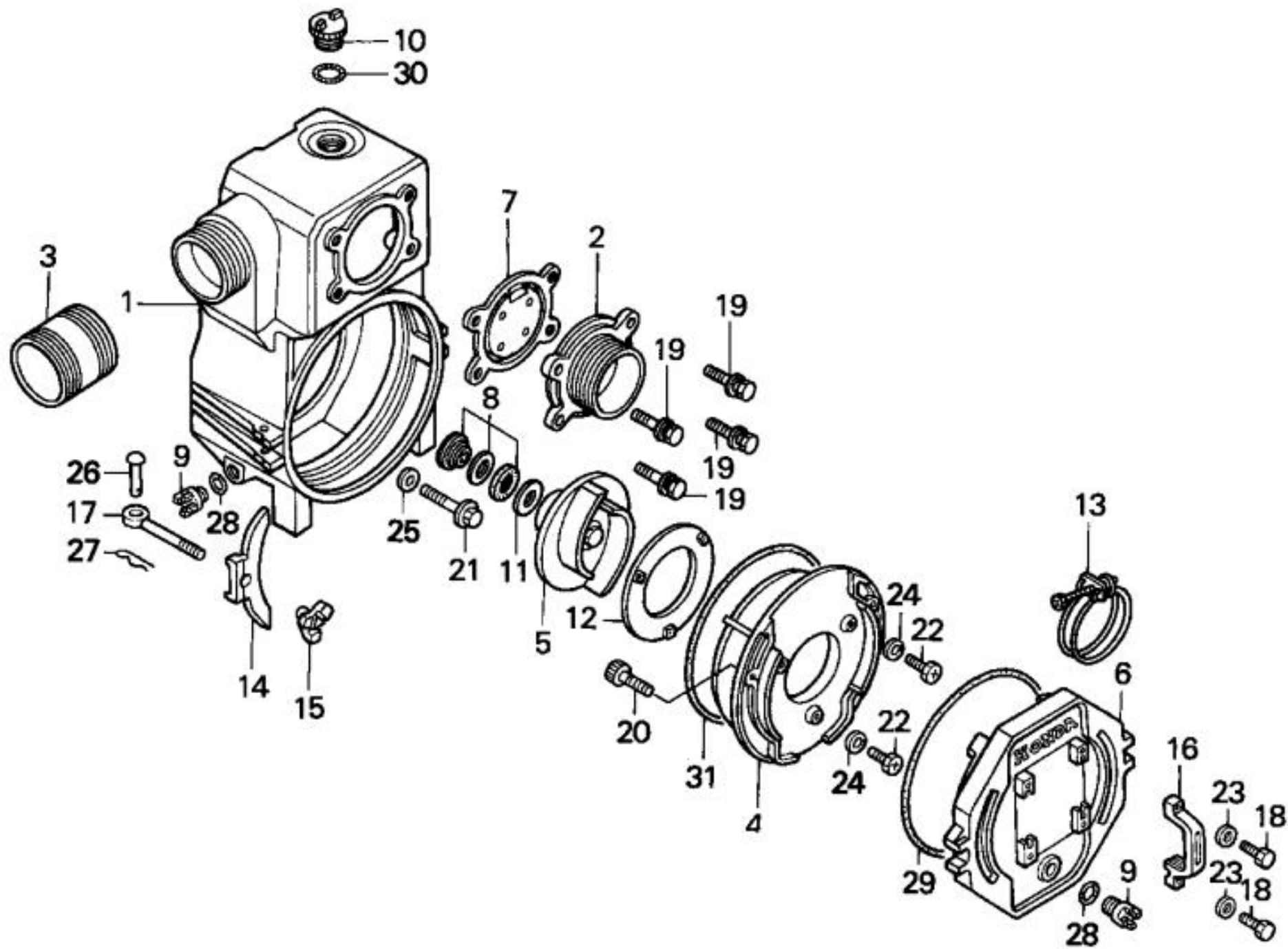

1	78101-YD4-013	CASING (Honda Code 3329794)
2	78103-YD4-003	INLET (Honda Code 2584357)
3	78104-YD4-003	OUTLET (Honda Code 2910933)
4	78105-YD4-003	CASE, VOLUTE (Honda Code 2584365)
5	78106-YD4-003	IMPELLER (Honda Code 2584373)
6	78108-YB9-003	COVER, DRAIN (Honda Code 2538700)
7	78110-YD4-003	VALVE, IN. (Honda Code 2584381)
8	78115-YB9-003	SEAL ASSY., MECHANICAL (Honda Code 2538742)
9	78117-YB8-003	CAP, DRAIN (Honda Code 2538759)
10	78119-YB8-003	CAP, FILLER (Honda Code 2538767)
11	78122-YD4-003	SHIM, ADJUSTER (Honda Code 2584399)
12	78123-YD4-003	LINER (Honda Code 2584407)
13	78139-YD4-003	BAND, HOSE (Honda Code 2584415)
14	78140-YB9-003	HOLDER, DRAIN COVER (Honda Code 2538841)
15	78202-YB9-003	KNOB, DRAIN COVER (Honda Code 2538874)
16	78207-YB8-003	HANDLE, DRAIN COVER (Honda Code 2538908)
17	90101-YB9-003	BOLT, DRAIN COVER (Honda Code 2538981)
18	90102-YB8-003	BOLT, HANDLE SETTING (Honda Code 2538999)
19	90102-YB9-003	BOLT-WASHER (10X30) (Honda Code 2539005)
20	90103-YB8-003	BOLT, SOCKET (8X20) (Honda Code 2539013)
20	90103-YD4-003	SOCKET, BOLT-WASHER (8X25) (Honda Code 2910925)
21	90105-YD4-003	BOLT, CASING SET (Honda Code 2584464)
22	90106-YD4-003	BOLT, LINER SETTING (5X14) (Honda Code 2584472)
23	90501-YB8-003	WASHER, PLAIN (6MM) (Honda Code 2539096)
24	90502-YD4-003	WASHER, SPRING (5MM) (Honda Code 2584480)
25	90503-YD4-003	WASHER, SEAL (Honda Code 2584498)
26	90751-YB9-003	PIN, HINGE (Honda Code 2539161)
27	90752-YB9-003	PIN, LOCK (Honda Code 2539187)
28	91351-YB8-003	O-RING (3.5X23.7) (Honda Code 2539195)
29	91351-YB9-003	O-RING (5.7X239.3) (Honda Code 2539203)
30	91352-YB8-003	O-RING (3.5X29.7) (Honda Code 2539211)
31	91352-YB9-003	O-RING (3.53X215.49) (Honda Code 2539229)



GX340K1

---

FOREWORD INDEX

**1**

---

ENGINE GROUP

**2**

---

PART NUMBER INDEX

**3**

---

PART NAME INDEX

**4**

---

**Instruction for use of parts catalogue**

- **This parts catalogue was prepared based on the latest information available as of February 10, 2008.**
- See the parts catalogue news for any revision that is made after February 10, 2008.
- **Always specify the part number when ordering a part.**
- Check the model, type, serial numbers, color, maker, and the size as needed before ordering a part.
- Note that the illustrations (part drawings) can differ from the actual parts in shape. They are given just to help you to refer to the parts.
- **When modifications or additions to this parts catalogue are made, a revised edition will be issued at an appropriate time, with successively progressing revision numbers on the cover. We recommend obtaining such revisions in order to keep your parts catalogue up-to-date at all times. To check whether a parts catalogue revision has been issued, please contact your Honda distributor.**

Initial version issue date **November 20, 2001**  
**Honda Motor Co., Ltd.**

**CONTENTS**

	Page	Address No.	
● Instruction for use of parts catalogue .....	1	B 1	<b>1</b>
● How to refer to the part information .....	2	B 2	
● Part catalogue structure .....	3	B 3	
● When the parts were revised .....	4	B 4	
● Abbreviations used in the parts catalogue .....	4	B 4	
● How to check the part block and serial numbers .....	5	B 5	
● Models, parts catalogue codes and applicable serial numbers .....	6	B 6	
● Features of each type .....	16	B16	
● Fuel hose, general purpose hoses and vinyl hose .....	33	D 1	
● FLAT RATE SERVICE TIME .....	34	D 2	
● Illustrated index .....	39	D 7	
● ENGINE GROUP .....	47	E 1	<b>2</b>
● PART NO. INDEX .....	353	2-L 1	<b>3</b>
● PART NAME INDEX .....	361	2-M 1	<b>4</b>

How to refer to the part information

A Reference with "Illustrated index"

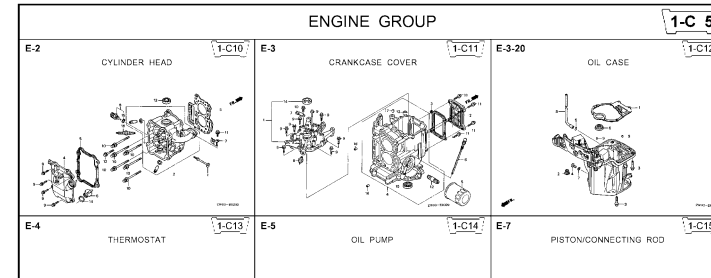

B Reference with "Part number index"

PART NO. INDEX

Part Number	Address	Page	Ref.	Part Number	Address	Page
06000				15212-ZW9-000	1-C14	3C
06316-ZW9-000	1-G9	88	1	15220-ZW9-003	1-C14	3C
11000				15332-ZW9-000	1-E8	55
11300-ZW9-405	1-C11	27	1	15332-ZW9-A30	1-E11	5E
11300-ZW9-406	1-C11	27	1	15400-PFB-004	1-C11	27
11340-ZW9-000	1-C11	27	2	15422-ZW9-000	1-C14	3C
11342-ZW9-000	1-C11	27	3	15473-881-000	1-C14	3C
11381-ZW9-003	1-C12	28	1	15474-ZW9-000	1-C14	3C
				15611-921-000	1-C10	2E
				15655-ZW9-000	1-C11	27
				16000		
12000				16010-ZV4-005	1-D4	3E
12000-ZW9-405ZA	1-C11	27	4	16011-ZV4-005	1-D4	3E
12155-ZV4-A00	1-C13	29	1	16013-ZW9-003	1-D4	3E
12166-ZW9-000	1-C10	26	1	16016-ZW9-003	1-D4	3E
12209-GB4-681	1-C16	32	1	16016-ZW9-721	1-D4	3E
12210-ZW9-405ZA	1-C10	26	2	16023-ZW9-003	1-D4	3E
12216-ZE2-300	1-E8	55	1	16024-ZV4-650	1-D4	3E
	1-E11	58	1	16028-ZV4-650	1-D4	3E

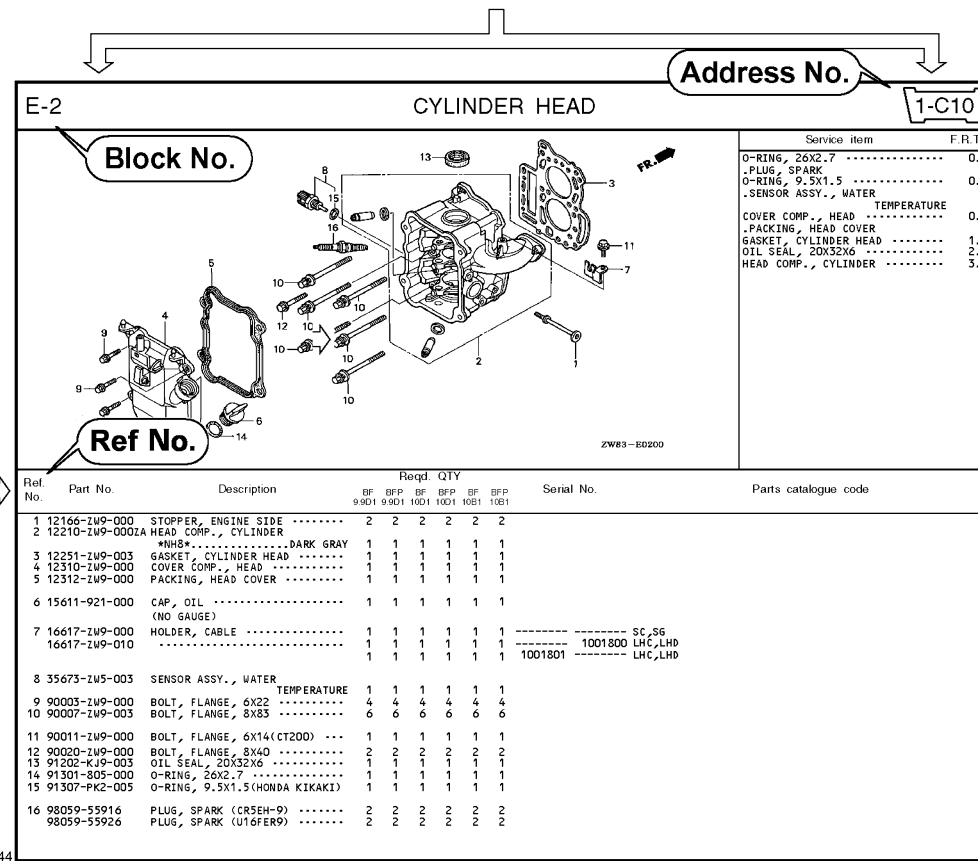

C Reference with "Part name index"

PART NAME INDEX

Part name	Address	Page	Ref.
[ A ]			
ABSORBER , FUEL	1-E15	62	5
ARMATURE COMP.	1-D11	43	7
ARM COMP. , LINK JOINT	1-G6	85	18
ARM COMP. , SHIFT LINK	1-G6	85	14
ARM COMP. , TILT	1-F15	79	20
ARM , FUEL PUMP ROCKER	1-C16	32	4
ARM , REVERSE LOCK	1-F15	79	18
ARM , SHIFT LINK	1-F11	74	7
ARM , STOPPER	1-D1	33	12
ARM , THROTTLE REMOTE	1-F11	74	6
ARM , VALVE ROCKER	1-C16	32	3
[ B ]			
BAG , TOOL , 160MM	1-G5	84	10
BAND	1-G6	86	37
BAND B1 , WIRE	1-F6	69	1
BAND , CORD	1-F3	67	18
BAND , TUBE CLIP , 11MM	1-E15	63	20
BAND , TUBE CLIP , 12.5MM	1-E15	63	19

Page No.

2008.09.20 E

**Part catalogue structure**

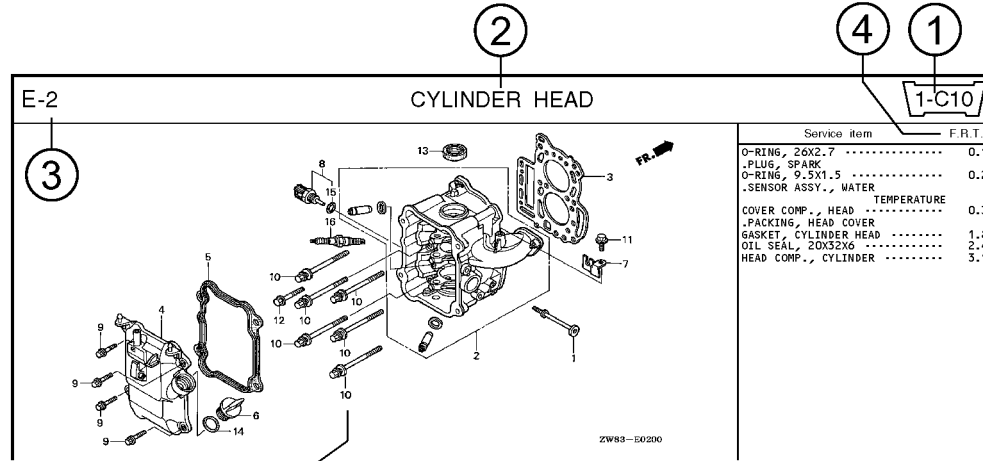

Ref. No.	Part No.	Description	Reqd. QTY						Serial No.	Parts catalogue code
			BF 9/9D1	BFP 9/9D1	BF 10D1	BFP 10D1	BF 10B1	BFP 10B1		
1	12166-ZW9-000	STOPPER, ENGINE SIDE	2	2	2	2	2	2		
2	12210-ZW9-000ZA	HEAD COMP., CYLINDER *NHS* ..... DARK GRAY	1	1	1	1	1	1		
3	12251-ZW9-003	GASKET, CYLINDER HEAD	1	1	1	1	1	1		
4	12310-ZW9-000	COVER COMP., HEAD	1	1	1	1	1	1		
5	12312-ZW9-000	PACKING, HEAD COVER	1	1	1	1	1	1		
6	15611-921-000	CAP, OIL (NO GAUGE)	1	1	1	1	1	1		
7	16617-ZW9-000	HOLDER, CABLE	1	1	1	1	1	1	SC,SG	
	16617-ZW9-010		1	1	1	1	1	1	1001800 LHC,LHD	

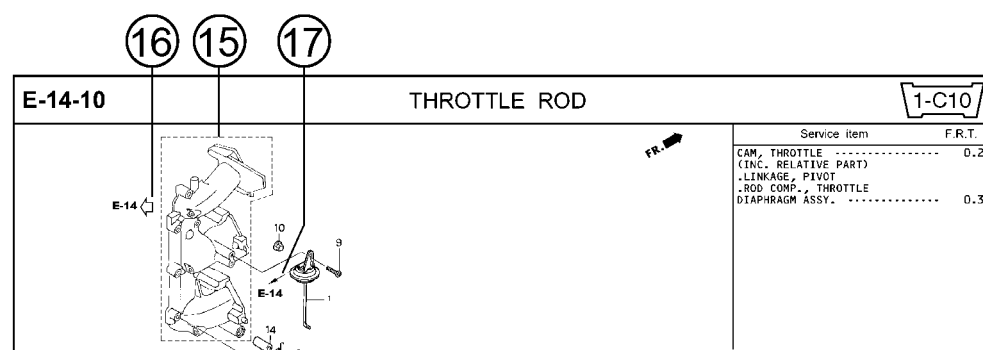

- ① **Address number**
  - Address No. is provided (in place of the page No.) to help you refer to the part with the part No. or part name.
- ② **Block title** ③ **Block number**
- ④ **Service item/Flat rate time**
- ⑤ **Reference number**
  - Title number marked with the parenthesis or parentheses indicates that it continues from the previous page.
- ⑥ **Part number** ⑦ **Honda color code**
- ⑧ **Description**
- ⑨ **Assemblies**
  - Sections framed with broken lines in the exploded view drawings are available as complete assemblies. (Their individual parts can also be obtained.)
- ⑩ **Color description**
- ⑪ **Note**
  - Notes are shown with the parentheses in the part name column.
- ⑫ **Required quantity**
  - Required QTY shown in the parenthesis or parentheses indicates the optional part.
  - Required QTY marked with "N" Indicates the optional part that should be selected as needed.
  - Required QTY indicates the number of the part used in the block.
- ⑬ **Serial number**
- ⑭ **Type**
  - When the type column is blank, it indicates that the part is applicable to all types.
  - As the type of the actual unit may differ from the "parts catalogue, type" please refer to "Models, types and applicable serial numbers" for confirmation.
- ⑮ **[Dotted box]**
  - Parts enclosed within a dotted line [ ] are covered in a different block.
- ⑯ **[Hollow arrow]**
  - A hollow arrow [ ] indicates the block No. for the parts enclosed within a dotted line [ ] .
- ⑰ **[Solid arrow]**
  - A solid arrow [ ] indicates the block No. the part in question is connected to.

When the parts were revised

Abbreviations used in the parts catalogue

1



Be sure to check the serial number!!



Ref. No.	Part No.	Description	Reqd. QTY						Serial No.
			BF 99D1	BFP 9.9D1	BF 10D1	BFP 10D1	BF 10B1	BFP 10B1	
1	12166-ZW9-000	STOPPER, ENGINE SIDE .....	2	2	2	2	2	2	
2	12210-ZW9-000ZA	HEAD COMP., CYLINDER *NHS* .....	1	1	1	1	1	1	
3	12251-ZW9-003	GASKET, CYLINDER HEAD .....	1	1	1	1	1	1	
4	12310-ZW9-000	COVER COMP., HEAD .....	1	1	1	1	1	1	
5	12312-ZW9-000	PACKING, HEAD COVER .....	1	1	1	1	1	1	
6	15611-921-000	CAP, OIL (NO GAUGE) .....	1	1	1	1	1	1	
7	16617-ZW9-000	HOLDER, CABLE (###) .....	1	1	1	1	1	1	SC, SG LHC, LHD LHC, LHD
	16617-ZW9-010	.....	1	1	1	1	1	1	

The number has been used from the initial model without revision.

When shown at the left side, it is applicable to the models of No.1001801 and the subsequent numbers.

When shown at the right side, it is applicable to the models up to No.1001800.

• The parts listed with "###" at the end of the parts name have limited supply period (parts not for sale).

• The following abbreviations are used in the parts name column.

- A ..... Ampere
- A.C. .... Alternating current
- ASSY. .... Assembly
- AT. .... Automatic transmission
- C.D.I. .... Capacitive discharge ignition
- COMP. ... Complete
- D.C. .... Direct current
- EX. .... Exhaust
- G.F.C.I ... Ground fault circuit interruptor
- HEX. .... Hexagonal
- H.S.T. .... Hydrostatic transmission
- FR. ....Front
- IN. ....Inlet
- L (100L) .Link (100 Links)
- L. ....Left
- MM .....Millimeter
- MT. ....Manual Transmission
- P.T.O. ....Power take off
- R. ....Right
- RR. ....Rear
- STD. ....Standard
- T (22T) ...Tooth (22 Teeth)
- V .....Volt
- W .....Watt



How to check the part block and serial numbers

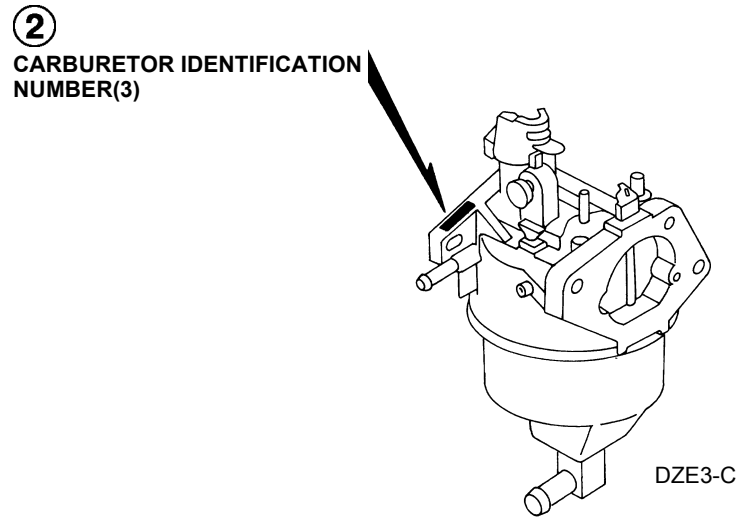
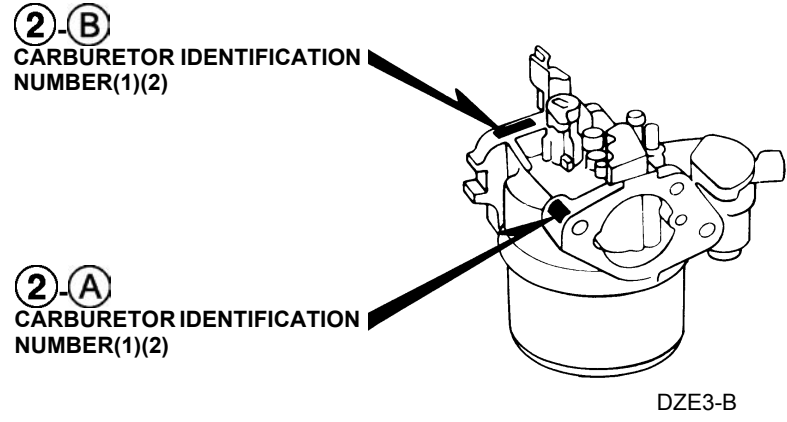
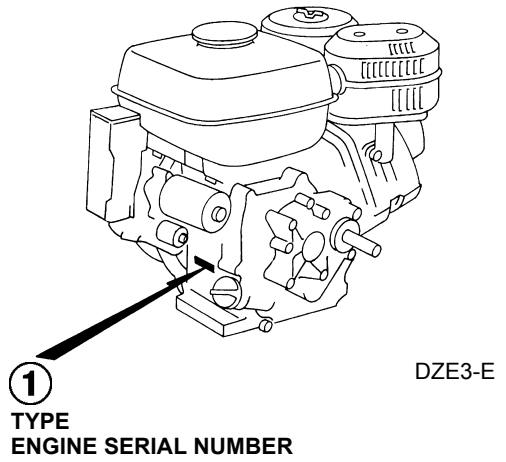
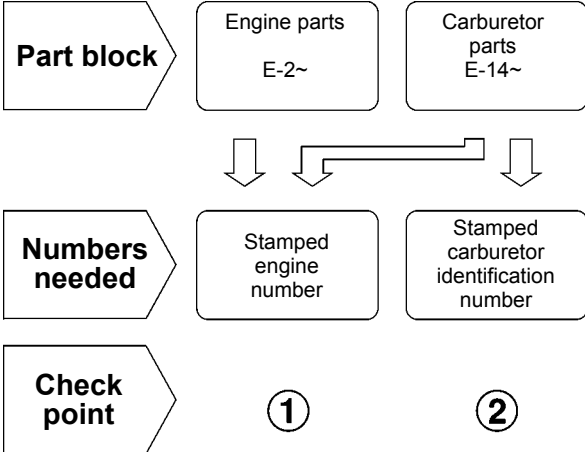

### Models, parts catalogue codes and applicable serial numbers

- Models, parts catalogue codes and applicable serial Nos. given in this parts catalogue can be identified as follows.

Model	Type	Parts catalogue type	Applicable engine serial No.	Applicable carburetor identification No.	Model	Type	Parts catalogue type	Applicable engine serial No.	Applicable carburetor identification No.
GX340K1 (1)	BJ	BJ	GC05- 2000001~3599999	BE34B B / C	GX340K1 (1)	EDS6	EDS6/A	GC05- 3600001~9999999	BE82B B / C
	EDE2	EDE2		BE82B A / B		EDT	EDT	GC05- 2000001~3599999	BE82B B
		EDE2/A	GC05- 3600001~9999999	BE82B B / C			EDT/A	GC05- 3600001~9999999	BE82B B / C
	EDK	EDK	GC05- 3600001~	BE34C C		EDT1	EDT1	GC05- 2000001~3599999	BE37B A / B / C BE82B B
	EDN	EDN	GC05- 2000001~	BE37B A / B / C BE82B B			EDT1/A	GC05- 3600001~	BE82B B BE82M A / B
	EDN2	EDN2	GC05- 2000001~3599999	BE82B A / B		EDT2	EDT2	GC05- 2000001~3599999	BE82B B
		EDN2/A	GC05- 3600001~9999999	BE82B B / C		EDT3	EDT3	GC05- 3600001~	BE82M B
	EDN5	EDN5	GC05- 2000001~3599999	BE34C B BE80D B / C		EDT6	EDT6	GC05- 2000001~3599999	BE82B B
		EDN5/A	GC05- 3600001~	BE80D B / C			EDT6/A	GC05- 3600001~9999999	BE82B B / C
	EDS	EDS	GC05- 2000001~3599999	BE37B A / B / C BE82B B		ED6	ED6	GC05- 2000001~3599999	BE37B A / B BE82B A / B
	EDS1	EDS1		GC05- 3600001~			BE82B B BE82M A / B	ED6/A	GC05- 3600001~9999999
		EDS2	EDS2	GC05- 2000001~3599999		BE82B B	ED7	ED7	GC05- 2000001~
	EDS2/A		GC05- 3600001~9999999	BE82B B / C		ED8	ED8	GC05- 2000001~3599999	BE80D B / C
	EDS3	EDS3	GC05- 2000001~	BE37B A / B / C BE82B B			ED8/A	GC05- 3600001~	BE80D B / C
	EDS4	EDS4	GC05- 3600001~	BE82M A / B		ED9	ED9	GC05- 2000001~3599999	BE34B B / C BE34C B
	EDS5	EDS5	GC05- 2000001~	BE38A D / E			ED9/A	GC05- 3600001~	BE34C B / C
EDS6	EDS6	GC05- 2000001~3599999	BE82B B	EMT	EMT	GC05- 2000001~3599999	BE82B B		
					EMT/A	GC05- 3600001~	BE82B B BE82M A / B		

Model	Type	Parts catalogue type	Applicable engine serial No.	Applicable carburetor identification No.	Model	Type	Parts catalogue type	Applicable engine serial No.	Applicable carburetor identification No.	
GX340K1 (1)	EN	EN	GC05- 2000001~3599999	BE34B B / C BE34C B	GX340K1 (1)	HA2	HA2	GC05- 2000001~3599999	BE80B A / B	
	ENT	ENT		BE82B B			HA2/A	GC05- 3600001~9999999	BE80B B	
		ENT/A	GC05- 3600001~9999999	BE82B B / C		HH	GC05- 2000001~3599999	BE34B B / C		
	ENT2	ENT2				HX			HX	
	EN6	EN6	GC05- 2000001~3599999	BE82B B		HX2	HX2	GC05- 2000001~	BE80B A / B	
		EN6/A	GC05- 3600001~9999999	BE82B B / C		HX26	HX26	GC05- 2000001~3599999		
	ES	ES	GC05- 2000001~3599999	BE34B B / C BE34C B			HX26/A	HX26/A	GC05- 3600001~9999999	BE80B B
		ES1		ES1		BE34B B / C BE34C B BE80D B / C		LH	LH	GC05- 2000001~3599999
	ES1/A		GC05- 3600001~	BE80D B / C		LH/A	GC05- 3600001~		BE80B B	
	ES2	ES2	GC05- 2000001~3599999	BE37B A / B / C BE82B B		LHB1	LHB1	GC05- 2000001~3599999	BE34B B / C	
	ES3	ES3				GC05- 3600001~	BE82M A / B	LHB3	LHB3	GC05- 3600001~
		ES3/A	BE82B B	LHB3/A					BE80B B	
	ES4	ES4	GC05- 2000001~3599999	BE37B A / B / C BE82B B		LHB5	LHB5	GC05- 2000001~3599999	BE47A A / B	
		ES4/A	GC05- 3600001~	BE82B B BE82M A / B		LHC	LHC		BE34B B / C BE80B B	
	ET	ET	GC05- 2000001~3599999	BE34B B / C BE34C B		LHE	LHE	GC05- 3600001~	BE80B B	
	ETS	ETS				LHQ4	LHQ4		GC05- 2000001~3599999	BE34B B / C BE80B B
	ETX	ETX					LHQ4/A	GC05- 3600001~9999999	BE80B B	
	HA	HA				LHW	LHW	GC05- 2000001~	BE34B C	
	HAQ	HAQ				BE34B B / C BE80A A / B	LJ	LJ	GC05- 2000001~3599999	BE34B B / C BE80B B

1

Model	Type	Parts catalogue type	Applicable engine serial No.	Applicable carburetor identification No.	Model	Type	Parts catalogue type	Applicable engine serial No.	Applicable carburetor identification No.
GX340K1 (1)	LJ	LJ/A	GC05-3600001~	BE80B B	GX340K1 (1)	LXE2	LXE2/A	GC05-3600001~9999999	BE80B B
	LJG	LJG	GC05-2000001~3599999	BE34B B / C BE80B B		LXE4	LXE4	GC05-2000001~3599999	BE34B B / C BE80B B
		LJG/A	GC05-3600001~	BE80B B			LXE4/A	GC05-3600001~9999999	BE80B B
	LJS	LJS	GC05-2000001~3599999			LXE6	LXE6	GC05-2000001~3599999	BE80B A / B
		LJS/A	GC05-3600001~				LXE8		BE34B C BE80B B
	LJS1	LJS1	GC05-3600001~			LXE8	LXE8/A	GC05-3600001~9999999	BE80B B
	LKE	LKE	GC05-2000001~3599999	BE34B B / C BE80B B			LXQ4	LXQ4	GC05-2000001~3599999
		LKE/A	GC05-3600001~9999999	BE80B B		LXQ4/A		GC05-3600001~9999999	BE80B B
	LP	LP	GC05-2000001~	BE21C A / B		LXU	LXU	GC05-2000001~3599999	BE34B C BE80B B
	LSX	LSX	GC05-2000001~3599999	BE34B C			LXU/A	GC05-3600001~9999999	BE80B B
	LT	LT				GC05-3600001~	BE34B C / D	LXZ	GC05-2000001~3599999
		LT/A	BE80B B	LX2				LX2	
	LWD	LWD					GC05-2000001~3599999	BE80E A	LX26
	LWD1	LWD1	GC05-2000001~3599999	BE80E A		LX26/A			
		LWD1/A	GC05-3600001~			LX	PKT2	PKT2	GC05-2000001~3599999
	LX	LX	GC05-2000001~3599999	BE34B B / C BE80B B				PKT2/A	GC05-3600001~9999999
		LX/A	GC05-3600001~	BE80B B		PKT4	PKT4	GC05-2000001~3599999	
	LXE	LXE	GC05-2000001~3599999	BE34B B / C BE80B B			PKT4/A	GC05-3600001~9999999	
		LXE/A	GC05-3600001~	BE80B B		PKX2	PKX2		
	LXE2	LXE2	GC05-2000001~3599999	BE80B A / B					

Model	Type	Parts catalogue type	Applicable engine serial No.	Applicable carburetor identification No.	Model	Type	Parts catalogue type	Applicable engine serial No.	Applicable carburetor identification No.
GX340K1 (1)	PKX4	PKX4	GC05- 2000001~3599999	BE34B C BE80B B	GX340K1 (1)	QAH2	QAH2/A	GC05- 3600001~9999999	BE80B B
		PKX4/A	GC05- 3600001~9999999	BE80B B		QAP	QAP	GC05- 2000001~3599999	BE34B B / C BE80B A / B
	PX	PX	GC05- 2000001~3599999	BE34B B / C BE80B B		QAPE	QAPE		
		PX/A	GC05- 3600001~	BE80B B		QAP2	QAP2	GC05- 3600001~9999999	BE80B B
	PXA2	PXA2	GC05- 3600001~9999999			QAQ	QAQ		
	PXE8	PXE8	GC05- 2000001~3599999	BE34B C		QA2	QA2	GC05- 3600001~9999999	BE80B B
		PXE8/A	GC05- 3600001~9999999	BE34B C / D		QA2/A	QA2/A		
	QA	QA	GC05- 2000001~3599999	BE34B B / C		QA26	QA26	GC05- 2000001~3599999	BE80B A / B
	QAB2	QAB2	GC05- 3600001~9999999	BE80B B		QA26/A	QA26/A	GC05- 3600001~9999999	BE80B B
		QAB2/A				GC05- 3600001~9999999	BE80B B		
	QAC2	QAC2	GC05- 2000001~3599999	BE80C A / B BE80C B		QDW9	QDW9	GC05- 2000001~3599999	BE34B B / C BE80B B
		QAC2/A	GC05- 3600001~9999999			QDW9/A	QDW9/A	GC05- 3600001~9999999	
	QAE	QAE	GC05- 2000001~3599999	BE34B B / C BE80B A / B		QE	QE	GC05- 2000001~3599999	BE34B B / C BE80B B
	QAE2	QAE2	GC05- 3600001~9999999	BE80B B		QE/A	QE/A	GC05- 3600001~9999999	
		QAE2/A		GC05- 3600001~9999999		BE80B B	QH	QH	GC05- 2000001~3599999
	QAE6	QAE6	GC05- 2000001~3599999	BE80B A / B		QH/A	QH/A	GC05- 3600001~	BE80B B
		QAE6/A	GC05- 3600001~9999999	BE80B B		QHB3	QHB3	GC05- 2000001~3599999	BE34B B / C BE80B B
	QAG	QAG	GC05- 2000001~3599999			BE80B B	QHB3/A	QHB3/A	GC05- 3600001~
		QAG/A	GC05- 3600001~9999999	QHB5			QHB5	GC05- 2000001~3599999	BE80B B
	QAH2	QAH2	GC05- 2000001~3599999			QHC	QHC	GC05- 2000001~3599999	BE47A A / B

1

Model	Type	Parts catalogue type	Applicable engine serial No.	Applicable carburetor identification No.	Model	Type	Parts catalogue type	Applicable engine serial No.	Applicable carburetor identification No.
GX340K1 (1)	QHE	QHE	GC05- 2000001~3599999	BE34B B / C BE80B B	GX340K1 (1)	QNE2	QNE2	GC05- 2000001~3599999	BE80B A / B
		QHE/A	GC05- 3600001~9999999	BE80B B			QNE2/A	GC05- 3600001~9999999	BE80B B
	QHP1	QHP1	GC05- 2000001~3599999	BE34B C BE80B B		QNE6	QNE6	GC05- 2000001~3599999	BE80B A / B
		QHP1/A	GC05- 3600001~	BE80B B		QNE9	QNE9	GC05- 2000001~3599999	BE80A A / B
	QHQ4	QHQ4	GC05- 2000001~3599999	BE34B B / C BE80B B			QNE9/A	GC05- 3600001~9999999	BE80A B
		QHQ4/A	GC05- 3600001~9999999	BE80B B		QNR2	QNR2	GC05- 2000001~3599999	BE80B A / B
	QH2	QH2	GC05- 2000001~3599999	BE80B A / B			QNR2/A	GC05- 3600001~9999999	BE80B B
		QKA4	QKA4	GC05- 2000001~3599999		BE34B C	QNR6	QNR6	GC05- 2000001~3599999
	QKA4/A		GC05- 3600001~9999999	BE34B C / D		QNR6/A		GC05- 3600001~9999999	BE80B B
	QL2	QL2	GC05- 2000001~3599999	BE80B B		QN18	QN18	GC05- 2000001~	BE34B B / C BE80B B
	QME0	QME0	GC05- 2000001~3599999	BE34B B / C BE80B B		QP	QP	GC05- 2000001~3599999	BE34B B / C
		QME0/A	GC05- 3600001~9999999	BE80B B			QP/A	GC05- 3600001~	BE34B C / D
	QME8	QME8	GC05- 2000001~3599999	BE34B C		QPE2	QPE2	GC05- 2000001~	BE80B A / B
		QME8/A	GC05- 3600001~9999999	BE34B C / D		QT	QT	GC05- 2000001~3599999	BE34B B / C
	QMH	QMH	GC05- 2000001~3599999	BE34B C BE80B B			QT/A	GC05- 3600001~	BE34B C / D
		QMH/A	GC05- 3600001~	BE80B B		QTC2	QTC2	GC05- 2000001~3599999	BE80B A / B
	QMT2	QMT2	GC05- 2000001~3599999	BE80B A / B			QTC2/A	GC05- 3600001~9999999	BE80B B
		QMT2/A	GC05- 3600001~9999999	BE80B B		QWH2	QWH2	GC05- 2000001~3599999	BE80C B
	QMX2	QMX2	GC05- 2000001~3599999	BE80B B			QWH2/A	GC05- 3600001~9999999	BE80C B
	QNE	QNE	GC05- 2000001~3599999	BE34B B / C		QX	QX	GC05- 2000001~3599999	BE34B B / C BE80B B

Model	Type	Parts catalogue type	Applicable engine serial No.	Applicable carburetor identification No.
GX340K1 (1)	QX	QX/A	GC05-3600001~	BE80B B
	QXB	QXB	GC05-2000001~3599999	BE34B B / C BE80D B / C BE80B B
		QXB/A	GC05-3600001~9999999	BE80B B
	QXB7	QXB7	GC05-2000001~3599999	
		QXB7/A	GC05-3600001~9999999	
	QXC	QXC	GC05-2000001~3599999	BE47A A / B BE80C B
		QXC/A	GC05-3600001~	BE80C B
	QXC4	QXC4	GC05-2000001~3599999	BE47A A / B
		QXC4/A	GC05-3600001~9999999	BE47A B / C
	QXC6	QXC6	GC05-2000001~3599999	BE80C A / B
		QXC6/A	GC05-3600001~9999999	BE80C B
	QXC9	QXC9	GC05-2000001~3599999	BE80C A / B
		QXC9/A	GC05-3600001~9999999	BE80C B
	QXE	QXE	GC05-2000001~3599999	BE34B B / C BE80B B
		QXE/A	GC05-3600001~	BE80B B
	QXEB	QXEB	GC05-2000001~3599999	BE34B B / C
	QXE2	QXE2	GC05-2000001~	BE80B A / B
	QXE4	QXE4	GC05-2000001~3599999	BE34B B / C BE80B B
		QXE4/A	GC05-3600001~9999999	BE80B B

Model	Type	Parts catalogue type	Applicable engine serial No.	Applicable carburetor identification No.
GX340K1 (1)	QXE6	QXE6	GC05-2000001~3599999	BE80B A / B
		QXE6/A	GC05-3600001~9999999	BE80B B
	QXE8	QXE8	GC05-2000001~3599999	BE34B C BE80B B
		QXE8/A	GC05-3600001~9999999	BE80B B
	QXQ4	QXQ4	GC05-2000001~3599999	BE34B B / C BE80B B
		QXQ4/A	GC05-3600001~9999999	BE80B B
	QXU	QXU	GC05-2000001~3599999	BE34B C BE80B B
		QXU/A	GC05-3600001~9999999	BE80B B
	QX2	QX2	GC05-2000001~3599999	BE80B A / B
	SDE	SDE	GC05-2000001~	BE34B B / C BE80B B
	SE	SE	GC05-2000001~3599999	
			SE/A	GC05-3600001~9999999
	SH	SH	GC05-2000001~3599999	BE34B B / C BE80B B
		SH/A	GC05-3600001~	BE80B B
	SHB1	SHB1	GC05-2000001~3599999	BE34B B / C BE80B B
	SHB3	SHB3		GC05-3600001~9999999
		SHB3/A	BE80B B	
	SHE	SHE	GC05-2000001~3599999	BE34B B / C BE80B B
	SHEZ	SHEZ		BE34B B / C
	SHQ4	SHQ4		BE34B B / C BE80B B

1

Model	Type	Parts catalogue type	Applicable engine serial No.	Applicable carburetor identification No.
GX340K1 (1)	SHQ4	SHQ4/A	GC05-3600001~9999999	BE80B B
	SHT	SHT	GC05-2000001~3599999	BE47A A / B
	SJ	SJ		BE34B B / C BE80B B
		SJ/A	GC05-3600001~	BE80B B
	SJG	SJG	GC05-2000001~3599999	BE34B B / C BE80B B
		SJG/A	GC05-3600001~	BE80B B
	SKE	SKE	GC05-2000001~3599999	BE34B C BE80B B
		SKE/A	GC05-3600001~	BE80B B
	SKZ	SKZ	GC05-2000001~3599999	BE34B B / C BE80B B
		SKZ/A	GC05-3600001~	BE80B B
	SME0	SME0	GC05-2000001~3599999	BE34B B / C BE80B B
		SME0/A	GC05-3600001~9999999	BE80B B
	SME2	SME2	GC05-2000001~3599999	BE80B A / B
	SMX2	SMX2		
			SMX2/A	GC05-3600001~9999999
	STJ	STJ	GC05-2000001~3599999	BE34B B / C
		STJ/A	GC05-3600001~	BE34B C / D
STP	STP	GC05-2000001~3599999	BE34B B / C BE80B B	
	STP/A	GC05-3600001~	BE80B B	
STQ	STQ	GC05-2000001~3599999	BE34B B / C BE80B B	

Model	Type	Parts catalogue type	Applicable engine serial No.	Applicable carburetor identification No.
GX340K1 (1)	STQ	STQ/A	GC05-3600001~	BE80B B
	STR	STR	GC05-2000001~3599999	BE34B C BE80B B
		STR/A	GC05-3600001~	BE80B B
	SWX	SWX	GC05-2000001~3599999	BE34B B / C
		SWX/A	GC05-3600001~9999999	BE34B C / D
	SX	SX	GC05-2000001~3599999	BE34B B / C BE80B B
		SX/A	GC05-3600001~	BE80B B
	SXB	SXB	GC05-2000001~3599999	BE34B B / C BE80D B / C BE80B B
		SXB/A	GC05-3600001~9999999	BE80B B
	SXB7	SXB7	GC05-2000001~3599999	
		SXB7/A	GC05-3600001~9999999	
	SXE	SXE	GC05-2000001~3599999	BE34B B / C BE80B B
		SXE/A	GC05-3600001~	BE80B B
	SXEB	SXEB	GC05-2000001~3599999	BE34B B / C BE80D B / C BE80B B
		SXEB/A	GC05-3600001~9999999	BE80B B
	SXE2	SXE2	GC05-2000001~3599999	BE80B A / B
	SXE4	SXE4		BE34B B / C BE80B B
			SXE4/A	GC05-3600001~9999999
	SXE8	SXE8	GC05-2000001~3599999	BE34B C BE80B B



Model	Type	Parts catalogue type	Applicable engine serial No.	Applicable carburetor identification No.	Model	Type	Parts catalogue type	Applicable engine serial No.	Applicable carburetor identification No.
GX340K1 (1)	SXE8	SXE8/A	GC05-3600001~9999999	BE80B B	GX340K1 (1)	VDE2	VDE2/A	GC05-3600001~9999999	BE80D B / C
	SXP	SXP	GC05-2000001~3599999	BE34B B / C		VD16	VD16	GC05-2000001~3599999	BE34B B / C BE34C B BE80B B
	SXQ4	SXQ4		BE34B B / C BE80B B		VE	VE		BE34B B / C BE34C B
		SXQ4/A	GC05-3600001~9999999	BE80B B		VEB6	VEB6		BE34B B / C BE34C B BE80B B
	SXU	SXU	GC05-2000001~3599999	BE34B C BE80B B			VH		VH
		SXU/A	GC05-3600001~9999999	BE80B B		VHE	VHE	GC05-2000001~3599999	BE34B B / C BE34C B
	VA	VA	GC05-2000001~3599999	BE34B B / C BE34C B		VH12	VH12	GC05-3600001~9999999	BE80B A / B BE80D B / C
	VAA	VAA				BE80B A / B BE80D B / C	VH12/A		VH12/A
	VAAE	VAAE		GC05-3600001~9999999				VH22	VH22
	VAD2	VAD2				GC05-3600001~9999999	BE80D B / C	VH22/A	VH22/A
		VAD2/A	BE80D B / C	VMQ			VMQ		GC05-3600001~
	VAH1	VAH1	GC05-2000001~3599999	BE34B B / C		VMT	VMT	GC05-2000001~3599999	BE37B C BE82B B
	VAH2	VAH2					BE80B A / B BE80D B / C	VMT/A	VMT/A
	VAW1	VAW1		GC05-3600001~9999999		VMX			VMX
	VA2	VA2				GC05-3600001~9999999	BE80D B / C	VNG	VNG
		VA2/A	BE80D B / C	VNG1			VNG1		
	VC2	VC2	GC05-2000001~3599999	BE82B B		VNG2	VNG2	GC05-3600001~9999999	BE80D B / C
		VC2/A	GC05-3600001~9999999	BE82E A		VSH7	VSH7		GC05-3600001~9999999
	VDE	VDE	GC05-2000001~3599999	BE34B B / C					
	VDE2	VDE2		BE80B A / B BE80D B / C					

1

Model	Type	Parts catalogue type	Applicable engine serial No.	Applicable carburetor identification No.
GX340K1 (1)	VS2	VS2	GC05- 3600001~	BE82M B
	VS3	VS3		BE82B B BE82M A / B
	VS4	VS4		BE82M A / B
	VS5	VS5		BE82B B BE82M A / B
	VS6	VS6		BE82M A / B
	VS7	VS7		BE82M B
	VTE2	VTE2	GC05- 2000001~3599999	BE82B B
	VWA	VWA		BE34B B / C
	VWA2	VWA2		BE80B A / B BE80D B / C
	VWC	VWC	GC05- 3600001~9999999	BE82E A
	VWC2	VWC2	GC05- 2000001~3599999	BE80B A / B BE80D B / C
		VWC2/A	GC05- 3600001~9999999	BE80B B
	VWE	VWE	GC05- 3600001~9999999	BE82B B / C
	VWE2	VWE2	GC05- 2000001~3599999	BE80B A / B BE80D B / C
		VWE2/A	GC05- 3600001~9999999	BE80D B / C
	VWS2	VWS2	GC05- 2000001~3599999	BE80B A / B BE80D B / C
		VWS2/A	GC05- 3600001~9999999	BE80B B
	VW12	VW12	GC05- 2000001~3599999	BE80B A / B BE80D B / C
		VW12/A	GC05- 3600001~9999999	BE80D B / C
	VX	VX	GC05- 2000001~3599999	BE34B B / C BE34C B BE80D B / C

Model	Type	Parts catalogue type	Applicable engine serial No.	Applicable carburetor identification No.
GX340K1 (1)	VX	VX/A	GC05- 3600001~	BE80D B / C
	VXA	VXA	GC05- 2000001~3599999	BE34B B / C BE34C B
	VXB	VXB		BE34B B / C BE34C B BE80D B / C
		VXB/A	GC05- 3600001~9999999	BE80D B / C
	VXB2	VXB2	GC05- 2000001~3599999	BE80B A / B BE80D B / C
	VXB7	VXB7	GC05- 3600001~9999999	BE80D B / C
		VXB7/A		
	VXE	VXE	GC05- 2000001~3599999	BE34B B / C BE34C B BE80D B / C
		VXE/A	GC05- 3600001~	BE80D B / C
	VXEB	VXEB	GC05- 2000001~3599999	BE34B B / C BE34C B BE80D B / C
		VXEB/A	GC05- 3600001~	BE80D B / C
	VXE2	VXE2	GC05- 2000001~3599999	BE80B A / B BE80D B / C
		VXE2/A	GC05- 3600001~9999999	BE80D B / C
	VXE4	VXE4	GC05- 2000001~3599999	BE34B B / C BE34C B BE80D B / C
	VXE6	VXE6		BE80B A / B BE80D B / C
	VXE7	VXE7	GC05- 3600001~9999999	BE80D B / C
		VXE7/A		
	VXE8	VXE8	GC05- 2000001~3599999	BE34C B BE80D B / C

Model	Type	Parts catalogue type	Applicable engine serial No.	Applicable carburetor identification No.	Model	Type	Parts catalogue type	Applicable engine serial No.	Applicable carburetor identification No.
GX340K1 (1)	VXE8	VXE8/A	GC05- 3600001~9999999	BE80D B / C	GX340K1 (1)	ZK1	ZK1	GC05- 2000001~3599999	BE30D A / D / E
	VXG	VXG	GC05- 2000001~3599999	BE34B B / C BE34C B			ZK1/A	GC05- 3600001~9999999	BE30D E
	VXK	VXK	GC05- 3600001~	BE80D B / C	GX340K1 (2)	L1	L1	GC05- 2000001~3599999	BE34A A / B BE34B B / C
	VXQ4	VXQ4	GC05- 2000001~3599999	BE34B B / C BE34C B BE80D B / C			L1/A	GC05- 3600001~	BE34A B BE34B C / D
		VXQ4/A	GC05- 3600001~9999999	BE80D B / C		P1	P1	GC05- 2000001~3599999	BE34A A / B BE34B B / C
	VXU	VXU	GC05- 2000001~3599999	BE34B B / C BE34C B BE80D B / C			P1/A	GC05- 3600001~	BE34A B BE34B C / D
		VXU/A	GC05- 3600001~	BE80D B / C	Q1	Q1	GC05- 2000001~3599999	BE34A A / B BE34B B / C BE47A A / B	
	VXU1	VXU1	GC05- 2000001~3599999	BE34B B / C BE34C B BE80D B / C		Q1/A	GC05- 3600001~	BE34A B BE34B C / D BE47A B / C	
		VXU1/A	GC05- 3600001~	BE80D B / C	S1	S1	GC05- 2000001~3599999	BE34A A / B BE34B B / C BE47A A / B	
	VX16	VX16	GC05- 2000001~3599999	BE34B B / C BE34C B BE80B B		S1/A	GC05- 3600001~	BE34A B BE34B C / D BE47A B / C	
		VX16/A	GC05- 3600001~9999999	BE80B B	V1	V1	GC05- 2000001~3599999	BE34A A / B BE34B B / C	
	VX8	VX8	GC05- 2000001~3599999	BE34C B BE80D B / C		GX340K1 (3) (Propane)	VXP	VXP	GDAE- 1000001~1000052
		VX8/A	GC05- 3600001~9999999	BE80D B / C	VXQP	VXQP			
	YJ	YJ	GC05- 2000001~3599999	BE34B B / C					

\* Of carburetor identification numbers, only the portions underlined in the example below are used for registration.

GX340K1 (1)(2) BE 34B B KC ナ

A B

GX340K1 (3) BE L4A A KC ナ

Features of each type

• See the following table for the features of each type. (Items in brackets are optional)

Model		GX340K1													
		Standard equipment (1)													
Specifications	Type	BJ	EDE2	EDK	EDN	EDN2	EDN5	EDS	EDS1	EDS2	EDS3	EDS4	EDS5	EDS6	EDT
	Crankshaft	25mmØ Straight													
25.4 mmØ Straight															
30 mmØ Straight															
20 mmØ Spline															
25.4 mmØ Spline															
30 mmØ Spline		●													
3/16" Tapered															
1/5" Tapered			●	●	●	●	●	●	●	●	●	●	●	●	●
Air cleaner	Silent	●	●	●	●	●	●	●	●	●	●	●	●	●	●
	Oil bath														
	Cyclone														
	Standard														
Muffler	Standard	●	●	●	●	●	●	●	●	●	●	●	●	●	●
	Silent														
Spark arrester		●	●	●	●			●	●	●	●			●	●
Oil alert		●	●	●	●	●	●	●	●	●	●	●	●	●	●
Starter motor		●						●	●	●	●	●	●	●	●
Reduction		●													

Model		GX340K1														
		Standard equipment (1)														
Specifications		Type	EDT1	EDT2	EDT3	EDT6	ED6	ED7	ED8	ED9	EMT	EN	ENT	ENT2	EN6	ES
		Crankshaft	25mmØ Straight													
25.4 mmØ Straight																
30 mmØ Straight																
20 mmØ Spline																
25.4 mmØ Spline																
30 mmØ Spline																
3/16" Tapered																
1/5" Tapered	●		●	●	●	●	●	●	●	●	●	●	●	●	●	●
Air cleaner	Silent	●	●	●	●	●	●	●	●	●	●	●	●	●	●	●
	Oil bath															
	Cyclone															
	Standard															
Muffler	Standard	●	●		●	●	●	●	●	●	●	●	●	●	●	●
	Silent															
Spark arrester		●	●	●	●	●			●			●	●	●		
Oil alert		●	●	●	●	●			●	●		●	●	●		
Starter motor								●				●	●			
Reduction																

Specifications		Model	GX340K1													
		Type	Standard equipment (1)													
			ES1	ES2	ES3	ES4	ET	ETS	ETX	HA	HAQ	HA2	HH	HX	HX2	HX26
Crankshaft	25mmØ Straight															
	25.4 mmØ Straight															
	30 mmØ Straight															
	20 mmØ Spline									●	●	●	●	●	●	●
	25.4 mmØ Spline															
	30 mmØ Spline															
	3/16" Tapered															
	1/5" Tapered	●	●	●	●	●	●	●	●							
Air cleaner	Silent	●	●	●	●	●	●	●	●	●	●	●	●	●	●	●
	Oil bath															
	Cyclone															
	Standard															
Muffler	Standard	●		●	●	●	●	●	●	●	●	●	●	●	●	●
	Silent															
Spark arrester		●		●	●					●	●	●	(●)	(●)	(●)	(●)
Oil alert		●	●	●	●			●		●		●		●	●	●
Starter motor					●			●								
Reduction										●	●	●	●	●	●	●

Specifications		Model	GX340K1												
		Type	Standard equipment (1)												
		LH	LHB1	LHB3	LHB5	LHC	LHE	LHQ4	LHW	LJ	LJG	LJS	LJS1	LKE	LP
Crankshaft	25mmØ Straight														
	25.4 mmØ Straight														
	30 mmØ Straight														
	20 mmØ Spline														
	25.4 mmØ Spline														
	30 mmØ Spline	●	●	●	●	●	●	●	●	●	●	●	●	●	●
	3/16" Tapered														
	1/5" Tapered														
Air cleaner	Silent	●	●	●	●		●	●		●	●		●	●	
	Oil bath								●			●			
	Cyclone					●									
	Standard														
Muffler	Standard	●	●	●	●	●	●	●		●	●	●	●	●	●
	Silent								●						
Spark arrester												●	●		
Oil alert														●	
Starter motor							●							●	
Reduction		●	●	●	●	●	●	●	●	●	●	●	●	●	●

Model		GX340K1													
		Standard equipment (1)													
Specifications	Type	LSX	LT	LWD	LWD1	LX	LXE	LXE2	LXE4	LXE6	LXE8	LXQ4	LXU	LXZ	LX2
	Crankshaft	25mmØ Straight													
25.4 mmØ Straight															
30 mmØ Straight															
20 mmØ Spline															
25.4 mmØ Spline															
30 mmØ Spline		●	●	●	●	●	●	●	●	●	●	●	●	●	●
3/16" Tapered															
1/5" Tapered															
Air cleaner	Silent	●		●		●	●	●	●	●	●	●	●	●	●
	Oil bath		●												
	Cyclone														
	Standard				●										
Muffler	Standard	●	●	●	●	●	●	●	●	●	●	●	●	●	●
	Silent														
Spark arrester		(●)				(●)						(●)	(●)		(●)
Oil alert		●				●	●	●	●	●	●	●	●	●	●
Starter motor				●	●		●	●	●	●	●				
Reduction		●	●	●	●	●	●	●	●	●	●	●	●	●	●



Model		GX340K1													
		Standard equipment (1)													
Specifications	Type	LX26	PKT2	PKT4	PKX2	PKX4	PX	PXA2	PXE8	QA	QAB2	QAC2	QAE	QAE2	QAE6
	Crankshaft	25mmØ Straight													
25.4 mmØ Straight										●	●	●	●	●	●
30 mmØ Straight															
20 mmØ Spline															
25.4 mmØ Spline			●	●	●	●	●	●	●						
30 mmØ Spline		●													
3/16" Tapered															
1/5" Tapered															
Air cleaner	Silent	●	●	●	●	●	●	●	●	●	●	●	●	●	●
	Oil bath														
	Cyclone														
	Standard														
Muffler	Standard	●	●	●	●	●	●	●	●	●	●	●	●	●	●
	Silent														
Spark arrester		(●)						(●)		●	●	●	●	●	●
Oil alert		●	●	●	●	●	●	●	●	●	●	●	●	●	●
Starter motor									●				●	●	●
Reduction		●													

Model		GX340K1													
		Standard equipment (1)													
Specifications	Type	QAG	QAH2	QAP	QAPE	QAP2	QAQ	QA2	QA26	QDW9	QE	QH	QHB3	QHB5	QHC
	Crankshaft	25mmØ Straight													
25.4 mmØ Straight		●	●	●	●	●	●	●	●	●	●	●	●	●	●
30 mmØ Straight															
20 mmØ Spline															
25.4 mmØ Spline															
30 mmØ Spline															
3/16" Tapered															
1/5" Tapered															
Air cleaner	Silent	●	●	●	●	●	●	●	●		●	●	●	●	
	Oil bath														
	Cyclone									●					●
	Standard														
Muffler	Standard	●	●	●	●	●	●	●	●	●	●	●	●	●	●
	Silent														
Spark arrester		●	●	●	(●)	●	●	●	●	●	●				
Oil alert		●	●	●	●	●		●	●	●					
Starter motor					●										
Reduction															

Specifications		GX340K1													
		Standard equipment (1)													
Model		QHE	QHP1	QHQ4	QH2	QKA4	QL2	QME0	QME8	QMH	QMT2	QMX2	QNE	QNE2	QNE6
Type															
Crankshaft	25mmØ Straight														
	25.4 mmØ Straight	●	●	●	●	●	●	●	●	●	●	●	●	●	●
	30 mmØ Straight														
	20 mmØ Spline														
	25.4 mmØ Spline														
	30 mmØ Spline														
	3/16" Tapered														
	1/5" Tapered														
Air cleaner	Silent	●	●	●	●	●	●	●	●	●	●	●	●	●	●
	Oil bath														
	Cyclone														
	Standard														
Muffler	Standard	●	●	●	●	●	●	●	●	●	●	●	●	●	●
	Silent														
Spark arrester						●	(●)					●	(●)	(●)	(●)
Oil alert						●	●	●	●		●	●	●	●	
Starter motor		●					●	●	●				●	●	●
Reduction															

Specifications		Model	GX340K1													
		Type	Standard equipment (1)													
			QNE9	QNR2	QNR6	QN18	QP	QPE2	QT	QTC2	QWH2	QX	QXB	QXB7	QXC	QXC4
Crankshaft	25mmØ Straight															
	25.4 mmØ Straight	●	●	●	●	●	●	●	●	●	●	●	●	●	●	●
	30 mmØ Straight															
	20 mmØ Spline															
	25.4 mmØ Spline															
	30 mmØ Spline															
	3/16" Tapered															
	1/5" Tapered															
Air cleaner	Silent	●	●	●	●		●		●		●	●	●			
	Oil bath					●		●								
	Cyclone									●				●	●	
	Standard															
Muffler	Standard	●	●	●	●	●	●	●	●	●	●				●	●
	Silent											●	●			
Spark arrester		(●)	(●)	(●)	(●)		(●)		●	(●)		●	●	(●)	(●)	
Oil alert		●	●	●	●		●		●	●	●	●	●	●	●	●
Starter motor		●	●	●	●		●									
Reduction																

Specifications		GX340K1													
		Standard equipment (1)													
Model	Type	QXC6	QXC9	QXE	QXEB	QXE2	QXE4	QXE6	QXE8	QXQ4	QXU	QX2	SDE	SE	SH
Crankshaft	25mmØ Straight												●	●	●
	25.4 mmØ Straight	●	●	●	●	●	●	●	●	●	●	●			
	30 mmØ Straight														
	20 mmØ Spline														
	25.4 mmØ Spline														
	30 mmØ Spline														
	3/16" Tapered														
	1/5" Tapered														
Air cleaner	Silent			●	●	●	●	●	●	●	●	●	●	●	●
	Oil bath														
	Cyclone	●	●												
	Standard														
Muffler	Standard	●	●	●		●	●	●	●	●	●	●	●	●	●
	Silent				●										
Spark arrester	(●)	(●)		●										●	
Oil alert	●	●	●	●	●	●	●	●	●	●	●				
Starter motor			●	●	●	●	●	●					●		
Reduction															

Specifications		GX340K1													
		Standard equipment (1)													
Model		SHB1	SHB3	SHE	SHEZ	SHQ4	SHT	SJ	SJG	SKE	SKZ	SME0	SME2	SMX2	STJ
Type															
Crankshaft	25mmØ Straight	●	●	●	●	●	●	●	●	●	●	●	●	●	●
	25.4 mmØ Straight														
	30 mmØ Straight														
	20 mmØ Spline														
	25.4 mmØ Spline														
	30 mmØ Spline														
	3/16" Tapered														
	1/5" Tapered														
Air cleaner	Silent	●	●	●	●	●		●	●	●	●	●	●	●	●
	Oil bath														
	Cyclone						●								
	Standard														
Muffler	Standard	●	●	●	●	●		●	●	●	●	●	●	●	●
	Silent						●								
Spark arrester							●					●	●		
Oil alert												●		●	●
Starter motor				●	●					●		●	●		●
Reduction															

Specifications		GX340K1													
		Standard equipment (1)													
Model		STP	STQ	STR	SWX	SX	SXB	SXB7	SXE	SXEB	SXE2	SXE4	SXE8	SXP	SXQ4
Type															
Crankshaft	25mmØ Straight	●	●	●	●	●	●	●	●	●	●	●	●	●	●
	25.4 mmØ Straight														
	30 mmØ Straight														
	20 mmØ Spline														
	25.4 mmØ Spline														
	30 mmØ Spline														
	3/16" Tapered														
	1/5" Tapered														
Air cleaner	Silent	●	●	●		●	●	●	●	●	●	●	●	●	●
	Oil bath				●										
	Cyclone														
	Standard														
Muffler	Standard	●	●	●	●	●			●		●	●	●	●	●
	Silent						●	●		●					
Spark arrester		●	●				●	●		●					
Oil alert					●	●	●	●	●	●		●	●	●	●
Starter motor									●	●	●	●	●		
Reduction															

Model		GX340K1															
		Standard equipment (1)															
Specifications		Type	SXU	VA	VAA	VAAE	VAD2	VAH1	VAH2	VAW1	VA2	VC2	VDE	VDE2	VD16	VE	
Crankshaft	25mmØ Straight		●														
	25.4 mmØ Straight																
	30 mmØ Straight																
	20 mmØ Spline																
	25.4 mmØ Spline																
	30 mmØ Spline																
	3/16" Tapered			●	●	●	●	●	●	●	●	●	●	●	●	●	●
	1/5" Tapered																
Air cleaner	Silent		●	●	●	●	●	●	●	●	●	●	●	●	●	●	
	Oil bath																
	Cyclone																
	Standard																
Muffler	Standard		●	●	●	●	●	●	●	●	●		●	●	●	●	
	Silent																
Spark arrester				●	●	●	●	●	●	●	●		●	●	●	●	
Oil alert			●	●	●	●	●	●	●		●	●		●			
Starter motor						●			●								
Reduction																	



Specifications		Model	GX340K1												
		Type	Standard equipment (1)												
		VEB6	VH	VHE	VH12	VH22	VMQ	VMT	VMX	VNG	VNG1	VNG2	VSH7	VS2	VS3
Crankshaft	25mmØ Straight														
	25.4 mmØ Straight														
	30 mmØ Straight														
	20 mmØ Spline														
	25.4 mmØ Spline														
	30 mmØ Spline														
	3/16" Tapered	●	●	●	●	●	●		●	●	●	●	●	●	●
	1/5" Tapered							●							
Air cleaner	Silent	●	●	●	●	●	●	●	●	●	●	●	●	●	●
	Oil bath														
	Cyclone														
	Standard														
Muffler	Standard	●	●	●	●	●	●	●	●						●
	Silent									●	●	●	●		
Spark arrester		●			●	●				●	●	●	●		
Oil alert					●	●	●	●	●	●	●	●	●	●	●
Starter motor		●		●		●	●	●				●			
Reduction															

Specifications		Model	GX340K1													
		Type	Standard equipment (1)													
			VS4	VS5	VS6	VS7	VTE2	VWA	VWA2	VWC	VWC2	VWE	VWE2	VWS2	VW12	VX
Crankshaft	25mmØ Straight															
	25.4 mmØ Straight															
	30 mmØ Straight															
	20 mmØ Spline															
	25.4 mmØ Spline															
	30 mmØ Spline															
	3/16" Tapered	●	●	●	●		●	●	●	●	●	●	●	●	●	●
	1/5" Tapered					●										
Air cleaner	Silent	●	●	●	●	●	●	●	●	●	●	●	●	●	●	●
	Oil bath															
	Cyclone															
	Standard															
Muffler	Standard	●	●	●		●	●	●				●		●	●	
	Silent									●			●			
Spark arrester						●	●	●		●		●	●	●		
Oil alert		●	●	●	●			●	●	●	●	●	●	●	●	
Starter motor			●	●	●		●	●			●	●	●			
Reduction																

Specifications		Model	GX340K1													
		Type	Standard equipment (1)													
			VXA	VXB	VXB2	VXB7	VXE	VXEB	VXE2	VXE4	VXE6	VXE7	VXE8	VXG	VXK	VXQ4
Crankshaft	25mmØ Straight															
	25.4 mmØ Straight															
	30 mmØ Straight															
	20 mmØ Spline															
	25.4 mmØ Spline															
	30 mmØ Spline															
	3/16" Tapered	●	●	●	●	●	●	●	●	●	●	●	●	●	●	●
	1/5" Tapered															
Air cleaner	Silent	●	●	●	●	●	●	●	●	●	●	●	●	●	●	●
	Oil bath															
	Cyclone															
	Standard															
Muffler	Standard	●				●		●	●	●		●		●	●	
	Silent		●	●	●		●				●		●			
Spark arrester			●	●	●		●				●		●			
Oil alert		●	●		●	●	●	●	●		●	●		●	●	
Starter motor						●	●	●	●	●	●	●				
Reduction																

Specifications		GX340K1													
		Model	Standard equipment (1)						Selective equipment (2)				Propane (3)		
		Type	VXU	VXU1	VX16	VX8	YJ	ZK1	L1	P1	Q1	S1	V1	VXP	VXQP
Crankshaft	25mmØ Straight										●				
	25.4 mmØ Straight									●					
	30 mmØ Straight					●									
	20 mmØ Spline														
	25.4 mmØ Spline								●						
	30 mmØ Spline						●	●							
	3/16" Tapered	●	●	●	●							●	●	●	
	1/5" Tapered														
Air cleaner	Silent	●	●	●	●	●		(●)	(●)	(●)	(●)	(●)	●	●	
	Oil bath							(●)	(●)	(●)	(●)	(●)			
	Cyclone							(●)	(●)	(●)	(●)	(●)			
	Standard						●								
Muffler	Standard	●	●	●	●	●		(●)	(●)	(●)	(●)	(●)	●	●	
	Silent							(●)	(●)	(●)	(●)	(●)			
Spark arrester								(●)	(●)	(●)	(●)	(●)			
Oil alert		●	●	●	●			(●)	(●)	(●)	(●)	(●)	●	●	
Starter motor			●				●	(●)	(●)	(●)	(●)	(●)			
Reduction							●	●							

## Fuel hose, general purpose hoses and vinyl hose

- The standard part fuel hose, general purpose hose and vinyl hose may be substituted by the coiled bulk part.
- When ordering the standard part fuel hose, general purpose hose and vinyl hose use the bulk part number written in the parts catalog in brackets ( ) underneath the part name.
- When exchanging the hose, cut and use at the specified length as mentioned in the part name.  
(For the method of cutting the bulk part, and method of filling out orders etc., please refer to the instructions issued with the bulk part.)

### Bulk part number of fuel hose, general purpose hose and vinyl hose.

Example: 9 5 0 0 1 - 7 5 0 0 1 - 5 0 M

**Bulk part number:**  
Refers to the bulk part.

**Marking code (fuel hose and general purpose hose)**

**Change code (Vinyl hose)**

Indicates number mark or change sequence, however, the code for the bulk part must be strictly 0 (zero).

**Types of code:**

- |             |  |                |  |              |   |
|-------------|--|----------------|--|--------------|---|
| • Fuel hose | 2: Red outside braid<br>(3 mm inside dia. only)        | • General hose | 1: Ash gray<br>2: Ash gray<br>3: Black<br>5: Black | • Vinyl hose | 1: Clear<br>2: Black<br>3: Light red<br>6: Light red<br>7: Pale black |
|             | 5: Black inside braid                                  |                |  |              |   |
|             | 3: Red (3 mm inside dia. only)                         |                |  |              |   |
|             | 4: Ash gray with red stripe<br>(3 mm inside dia. only) |                |  |              |   |
|             | 6: Black   |                |  |              |   |

**Lengths:**

- 001: 1 m (standard)  
003: 3 m  
008: 8 m } Application or specification of some parts is not settled.

**I.D code: (fuel hose and general purpose hose)**

- |            |                    |                    |                             |                             |
|------------|--------------------|--------------------|-----------------------------|-----------------------------|
| 30: 3.0 mm | 50: 5.0 mm         | 70: 7.0 mm         | 11: 11 mm                   | 12: 12 (outside dia. 17) mm |
| 35: 3.5 mm | 55: 5.3 mm, 5.5 mm | 75: 7.3 mm, 7.5 mm | 91: 12 (outside dia. 15) mm | 14: 14 mm                   |
| 45: 4.5 mm | 65: 6.5 mm         | 80: 8.0 mm         | 92: 12 (outside dia. 16) mm | 17: 17 mm                   |

**ID./OD. code: (vinyl hose)**

- |                         |                          |                           |                           |                           |
|-------------------------|--------------------------|---------------------------|---------------------------|---------------------------|
| 01: ID. 2.9, OD. 6.8 mm | 12: ID. 5.0, OD. 7.0 mm  | 21: ID. 8.0, OD. 9.0 mm   | 37: ID. 11.0, OD. 15.0 mm | 50: ID. 16.0, OD. 19.0 mm |
| 03: ID. 3.0, OD. 6.0 mm | 10: ID. 5.0, OD. 8.0 mm  | 23: ID. 8.0, OD. 12.0 mm  | 38: ID. 12.0, OD. 13.0 mm | 55: ID. 17.5, OD. 20.5 mm |
| 05: ID. 3.5, OD. 6.5 mm | 11: ID. 5.0, OD. 9.0 mm  | 25: ID. 9.0, OD. 11.0 mm  | 39: ID. 12.0, OD. 14.0 mm | 60: ID. 22.0, OD. 27.0 mm |
| 07: ID. 4.0, OD. 7.0 mm | 14: ID. 6.0, OD. 9.0 mm  | 27: ID. 9.0, OD. 13.0 mm  | 40: ID. 12.0, OD. 16.0 mm |                           |
| 08: ID. 4.5, OD. 6.5 mm | 17: ID. 7.0, OD. 9.0 mm  | 33: ID. 10.0, OD. 14.0 mm | 43: ID. 13.0, OD. 15.0 mm |                           |
| 09: ID. 4.5, OD. 8.0 mm | 19: ID. 7.0, OD. 11.0 mm | 36: ID. 11.0, OD. 13.0 mm | 45: ID. 14.0, OD. 18.0 mm |                           |

**Hose type:**

- 1: Fuel hose  
3: Vinyl hose  
5: General hose

⊙ **CAUTION: It is DANGEROUS to confuse the fuel hose with the general purpose hose or vinyl hose.**

Never use a general purpose hose or vinyl hose in place of a fuel hose or vice versa. Always use the correct bulk part in the parts catalogue, according to the service manual or the instructions issued with the bulk part.

## FLAT RATE SERVICE TIME

Flat rate service time (FRT) means the standard time required to service a product, which is listed in this manual to help the dealers control the actual working process and calculate the service charge by using it as a guide.

### FRT setting system

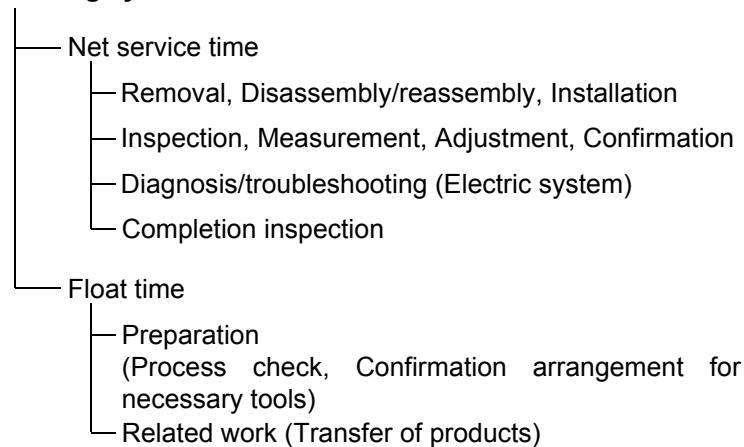

\* Float time is set by multiplying the net service time by a given coefficient.

### Editorial style

The service items shown in the text are listed with the exchange work time for the repair sales parts as the subject. Other representative service items not using repair parts (removal/installation, adjustment, inspection/measuring, and other work) are listed collectively in the list in the preface, classified according to the work.

### FRT setting standard

- Decimal system (in unit of 0.1) is adopted to set FRT as it is convenient to calculate the wage.  
Example: (0.1) → 6 minutes, (0.2) → 12 minutes  
[Labor cost per hour] x [FRT] = [Wage]
- FRT is set with a hand tool.
- Service items and FRT can be subject to change depending on development of tools and service equipment and improvement in service procedure.

**Work procedure**

- As the work procedure is set with the work time according to the method in the separate Service Manual, refer to this Manual as required.
- Work methods permitting servicing in the shortest time still permitting assurance of safe work and product warranty are used for the setting of service items not listed in the Service Manual.
- Work basically is to be performed by one person, and when two or more people are required, setting is done as the total time for the number of people.
- The set value for the technological level of the workers uses a person with three years of experience in the repair of Honda products as the standard.
- Special tools and service equipment used to set FRT are those specified or recommended in Service Manual.

**Service item whose FRT is not presented**

- Accessories and service parts that are not listed to use in this manual.
  - Locations with little aging deterioration or breakage during normal use.
  - Service work that can be finished by one touch.
  - Service work that is seldom done (i.e. extremely small causes of trouble and service frequency).
  - Products and parts whose location for installation differs according to its status of use and application.
- \* When FRT is not presented, please calculate wages based on appropriate actual work time.

**Operation not included of FRT**

- Oil and coolant water draining, Waiting time for warming up operation and etc..
- Additional operation that involves removal/installation of standard exterior equipment.
- Indirect time spent for service by visiting the customer, trade-in, and delivery.
- Indirect time required for ordering and delivery of parts.
- Cost for grease, adhesive agent, etc. used for service work.

**Explanation of FRT by using an example  
(The example may differ from the actual presented items)**

Ref. No.	L.O.N.	(Relative ref. Number) Description	F.R.T.
①	1111L1	(1, 3, 4, 7) VALVE, INTAKE .....4.1	②
②		• NOTE: OHV type	③
③	1111L1A	• Includes: Engine removal and installation One head (intake all) add .....1.4	④

- ① Reference No. of the illustration of part that shows location of the replacement work.
- ② FRT is an abbreviation of Flat Rate Time indicating the standard service time required for the replacement.
- ③ LON is an abbreviation of Labor Operation Number, and it is a classification of the service items by the work unit code.

The same operation code is used regardless of the models.

Standard operation is indicated with 6 digits code, and additional operation is indicated with 7 digits code.

- ④ Indicating the intake valve replacement and FRT4.1.
- ⑤ Indicating FRT1.4 that will be added when additional operation (whole intake side of one cylinder head) is done in association with intake valve replacement.

- ⑥ Indicating work condition or application condition of the service item.
- ⑦ Indicating work contents that are included in the service item.
- ⑧ Indicating a reference No. whose operation and time are the same as FRT4.1 for the intake valve.

(The application range is limited to the service items without an LON setting within a same block.)

**How to refer to the service item by using the sample  
(intake valve replacement)**

Open to the page of the block where the intake valve's spare part illustration is shown.

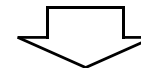

Look for the intake valve illustration, and refer to the service item and FRT that agree with the reference No.



Indication mark for the listing of service items that continues to the following page

Ref. No.	L.O.N.	(Relative ref. Number) Description	F.R.T.
2	1111L1	VALVE, INTAKE .....	4.1
	.	.	.
	.	.	.

+  
Mark indicated at the last line.

Indication of the block with no setting of FRT

Ref. No.	L.O.N.	(Relative ref. Number) Description	F.R.T.
NO INFORMATION .....			

• LON code system

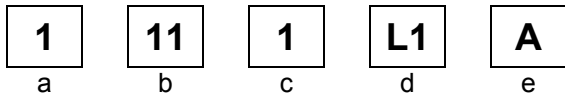

- a) Category code..... Engine
- b) Location/function code..... Engine upper
- c) Operation code..... Replace
- d) Operation sequence number (Unit code can be shown with alphabet)  
..... Intake valve  
(No regular rule of code)
- e) Additional code ..... One head (intake all)  
(No regular rule of code)

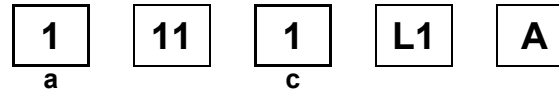

a) Category codes and classification

Code	Category
1	Engine
2	Power drive
3	Fuel & Exhaust
4	Frame & Body
5	Steering
6	Electrical
7	Axle & Brake
8	Control system
9	-
0	Attachments

c) Operation codes and classification

Code	Operation category
1	Replace, Removal/Installation, Change
2	Overhaul
3	Adjust, Rotation
4	(Paint-related work: Top-coat)
5	Test, Inspect/diagnose, Measurement
6	(Overhaul-related work: Rebore)
7	(Overhaul-related work: Reseal)
8	(Resurface)
9	(Paint-related work: Refinish)
0	Repair, Cleaning, Air bleeding

Major service items without using spare parts

- (1) Removal/Installation, (2) Adjustment,  
(3) Inspection/Measurement, (4) Overhaul, (5) Other work

E: Engine, T: Transmission, D: Drive system,  
B: Body and related parts

### (1) Removal/Installation

Set with the parts configuration in the status of being removed from the product.

	LON	DESCRIPTION	FRT
E	1111L3	CYLINDER HEAD ASSEMBLY-REMOVAL/INSTALLATION	0.5

### (2) Adjustment

	LON	DESCRIPTION	FRT
E	1113A1	VALVE CLEARANCE-ADJUSTMENT NOTE: For 1 product	0.3
	1163A0	CONTROL, THROTTLE/GOVERNOR-ADJUSTMENT	0.2
	3113A2	CARBURETOR IDLE-ADJUSTMENT	0.2

### (3) Inspection, Measurement, Cleaning

	LON	DESCRIPTION	FRT
E	1105A0	ENGINE OIL-INSPECTION	0.1
	3120A0	AIR CLEANER-CLEANING INCLUDES: Air cleaner-inspection	0.2
	3130A0	SPARK ARRESTER-CLEANING INCLUDES: Spark arrester-inspection	0.1
	6140A0	SPARK PLUG-ADJUSTMENT/CLEANING NOTE: For 1 product	0.1

### (4) Overhaul

Work condition: The required Measurements, inspections, adjustments, and cleaning/washing of each part are performed, including the main body removal/installation work and the replacement of defective parts.

	LON	DESCRIPTION	FRT
E	3112A0	CARBURETOR-OVERHAUL INCLUDES: All necessary adjustment	0.6

### (5) Other work

	LON	DESCRIPTION	FRT
E	1101E1	ENGINE OIL-CHANGE INCLUDES: Engine oil-inspection	0.2

# ENGINE GROUP

**D 7**

**E-2**

**CYLINDER HEAD**

**E 1**

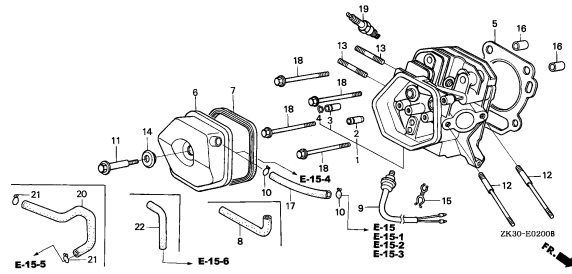

**E-3**

**CYLINDER BARREL**

**E16**

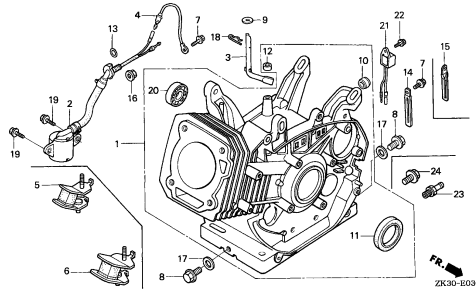

**E-6**

**CRANKCASE COVER(1)**

**F14**

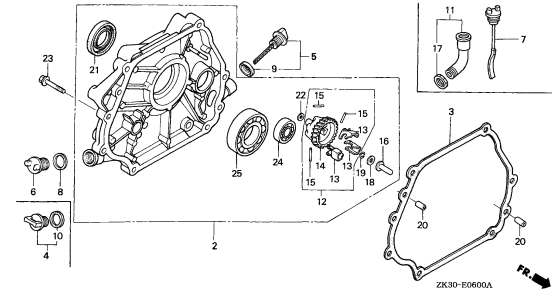

**E-6-1**

**CRANKCASE COVER(2)**

**G13**

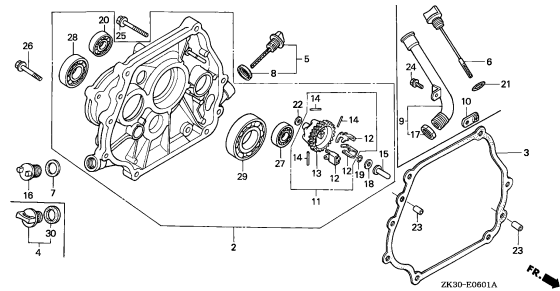

**E-6-2**

**CRANKCASE COVER(3)**

**H 1**

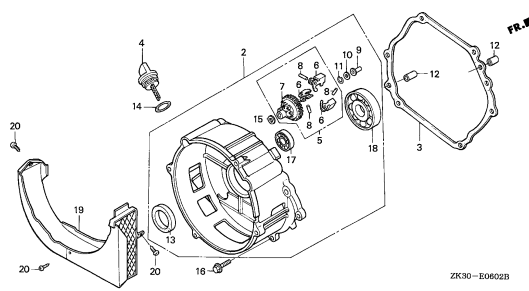

**E-7**

**CRANKSHAFT**

**H 3**

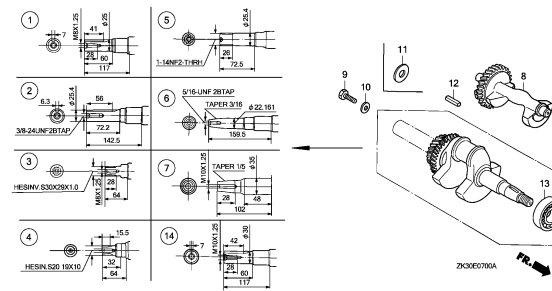

**E-8**

**PISTON**

**H 6**

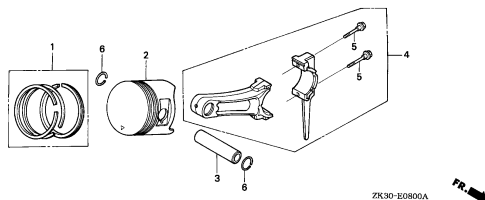

**E-9**

**CAMSHAFT**

**I 6**

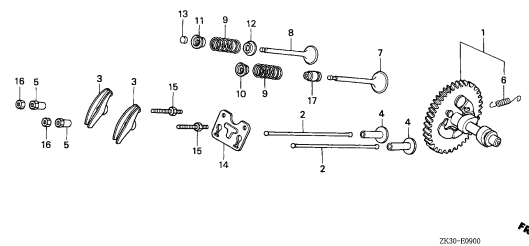

**E-11**

**RECOIL STARTER**

**I11**

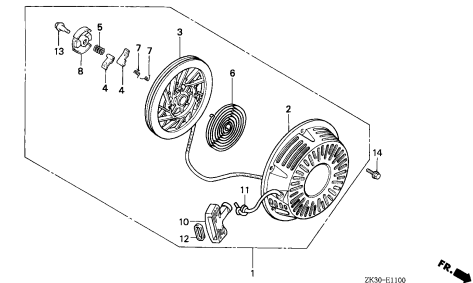

**2**

# ENGINE GROUP

D 8

E-12

FAN COVER(1)

J 9

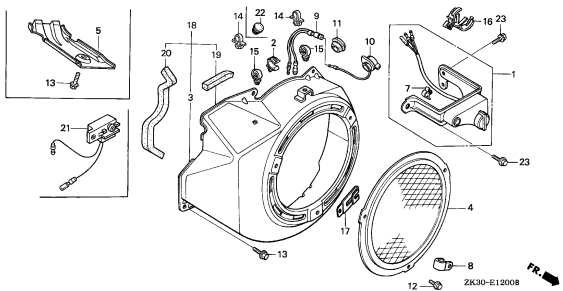

E-12-1

FAN COVER(2)

K 2

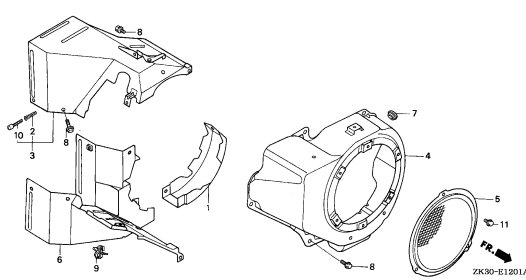

E-14

CARBURETOR(1)

K 3

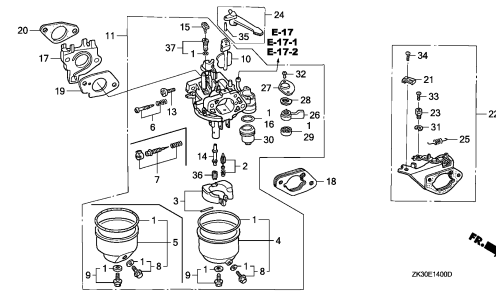

E-14-1

CARBURETOR(2)

M 4

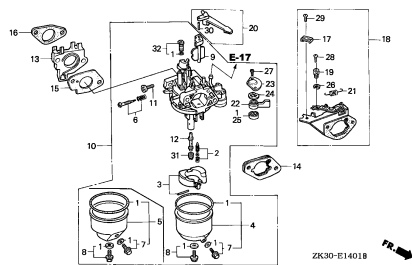

E-14-2

CARBURETOR(3)

M 6

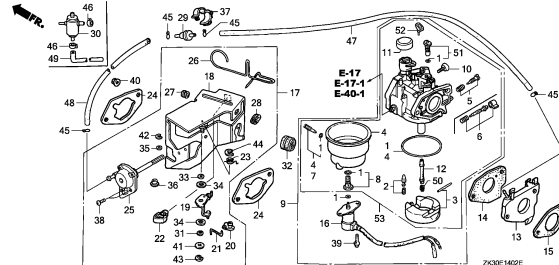

E-14-3

CARBURETOR(4)

M13

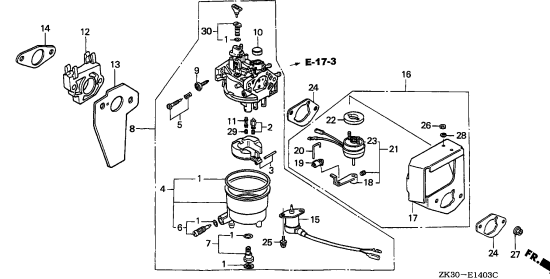

E-14-4

CARBURETOR(5)

M15

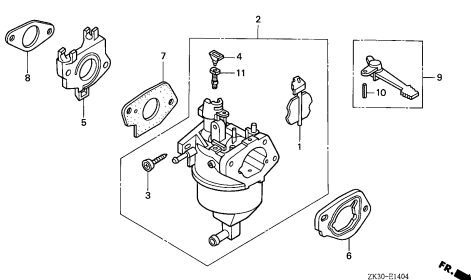

E-14-5

CARBURETOR(6)

M16

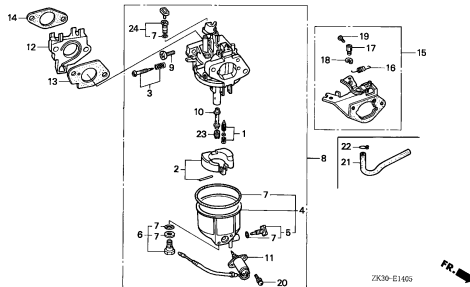

E-14-6

CARBURETOR(7)

N 2

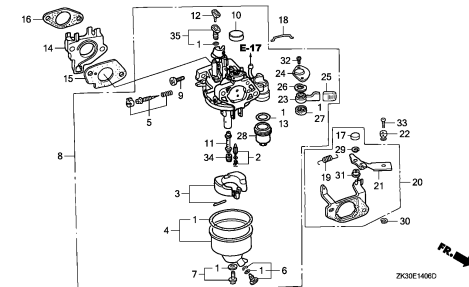

2

# ENGINE GROUP

**D 9**

**E-15**

**AIR CLEANER(1)**

**N 4**

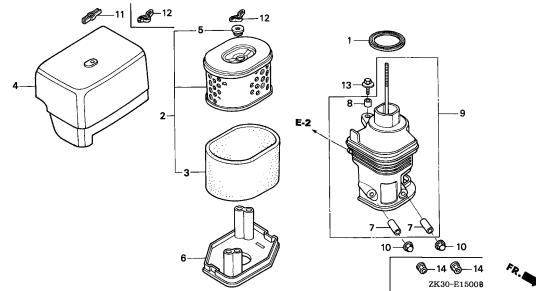

**E-15-1**

**AIR CLEANER(2)**

**N15**

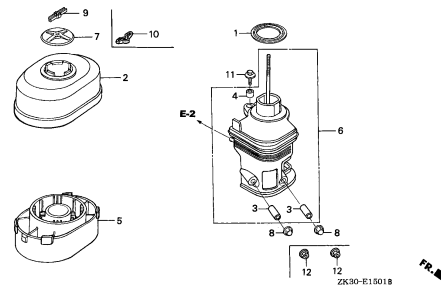

**E-15-2**

**AIR CLEANER(3)**

**N16**

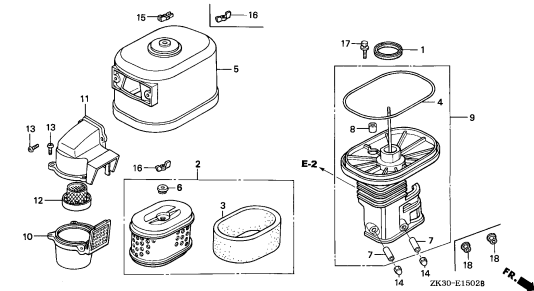

**E-15-3**

**AIR CLEANER(4)**

**2-B 2**

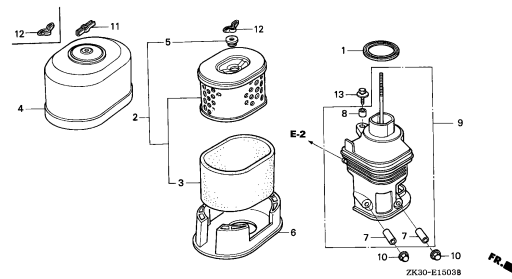

**E-15-4**

**AIR CLEANER(5)**

**2-B 3**

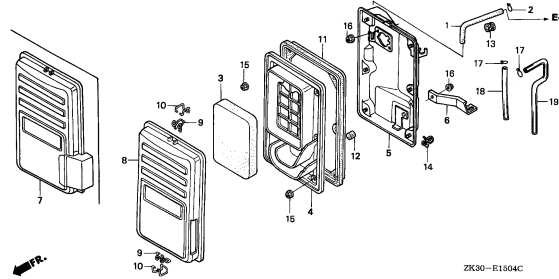

**E-15-5**

**AIR CLEANER(6)**

**2-B 6**

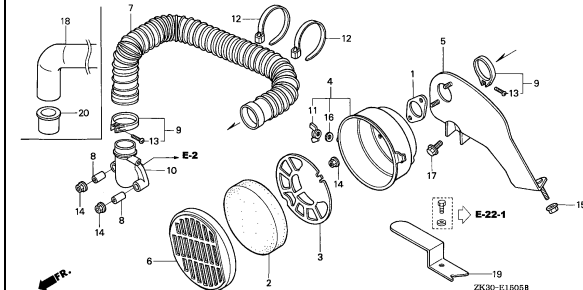

**E-15-6**

**AIR CLEANER(7)**

**2-B 8**

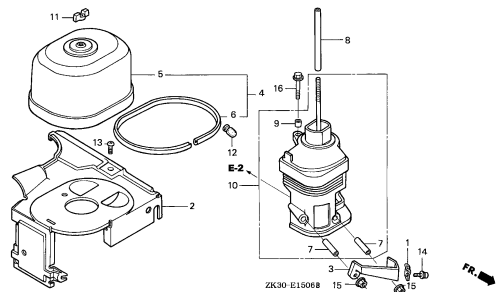

**E-16**

**MUFFLER(1)**

**2-B 9**

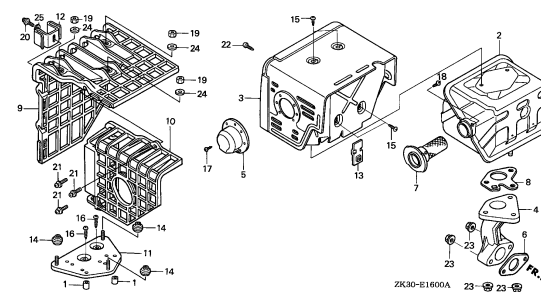

**E-16-1**

**MUFFLER(2)**

**2-B12**

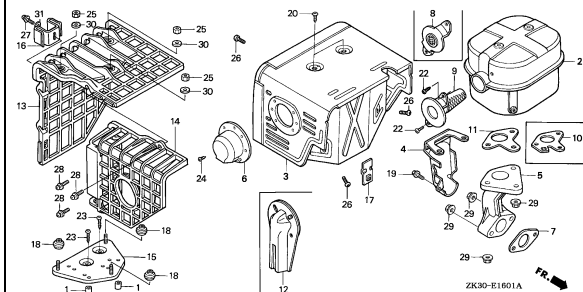

**2**

# ENGINE GROUP

**D10**

**E-16-2**

MUFFLER(3)

**2-C 8**

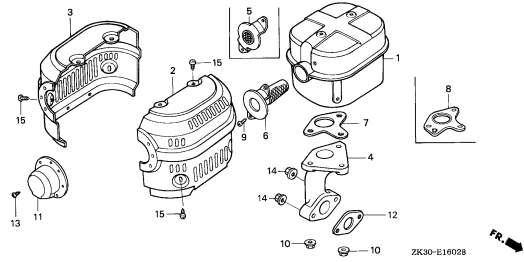

**E-16-3**

MUFFLER(4)

**2-C10**

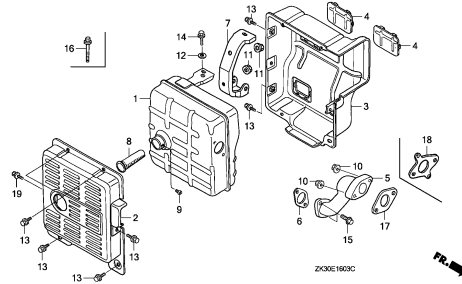

**E-16-4**

MUFFLER(5)

**2-C12**

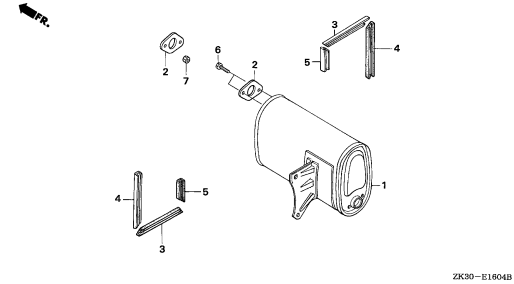

**E-17**

FUEL TANK(1)

**2-C13**

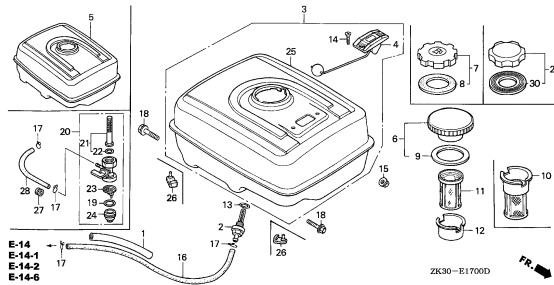

**E-17-1**

FUEL TANK(2)

**2-D 9**

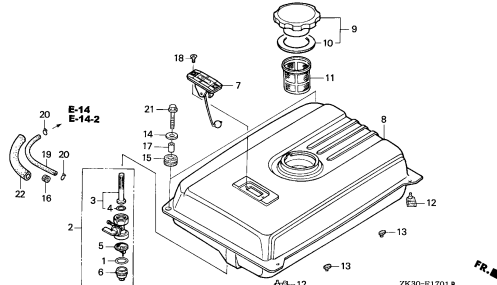

**E-17-2**

FUEL TANK(3)

**2-D12**

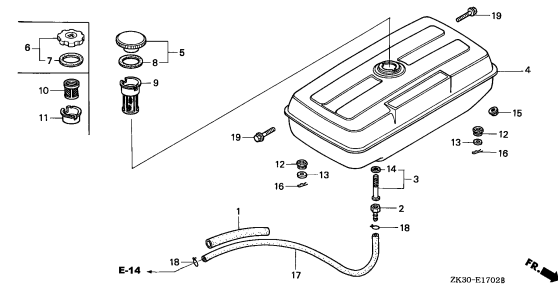

**E-17-3**

FUEL TANK(4)

**2-D13**

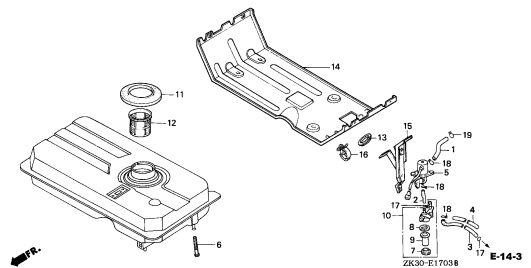

**E-19**

FLYWHEEL

**2-D14**

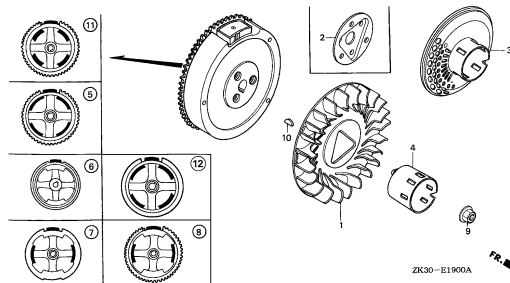

**E-20**

IGNITION COIL(1)

**2-E 2**

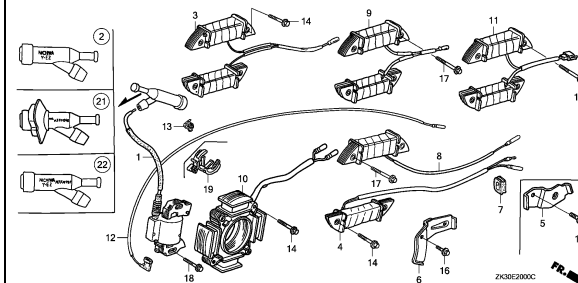

# ENGINE GROUP

**D11**

**E-20-1**

IGNITION COIL(2)

**2-E 9**

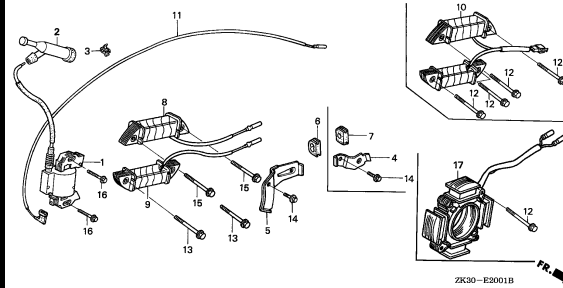

**E-20-2**

IGNITION COIL(3)

**2-E10**

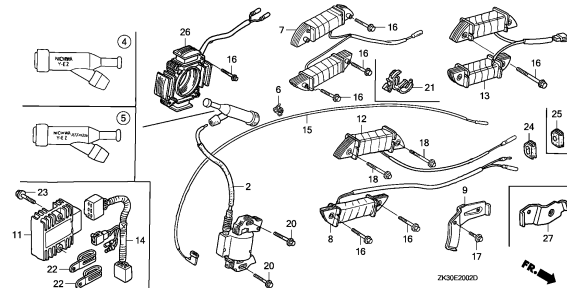

**E-21**

STARTER MOTOR

**2-E12**

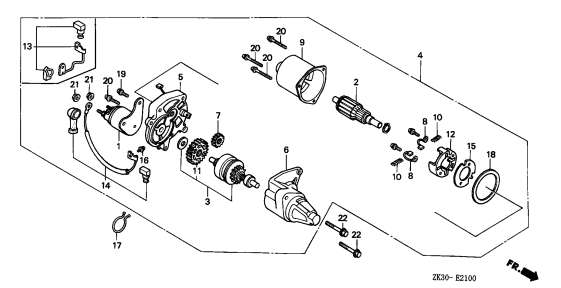

**E-22**

CONTROL(1)

**2-F 3**

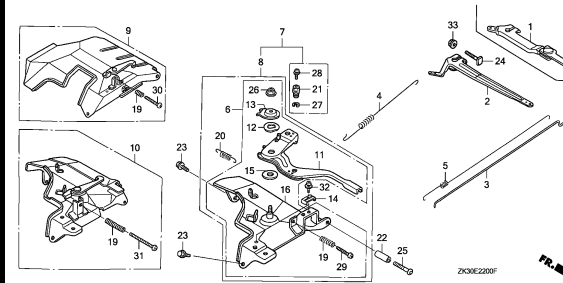

**E-22-1**

CONTROL(2)

**2-G 2**

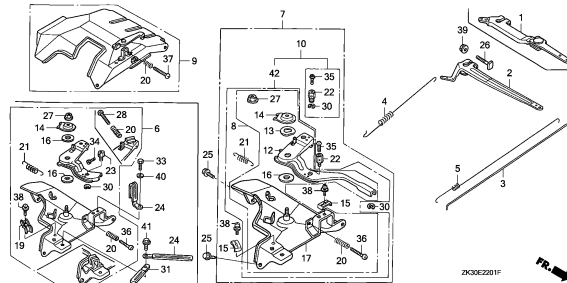

**E-22-2**

CONTROL(3)

**2-G 6**

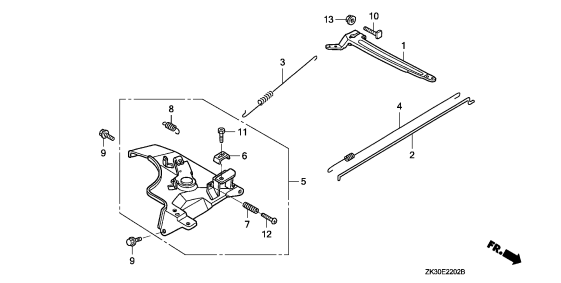

**E-22-20**

AUTO THROTTLE

**2-G 7**

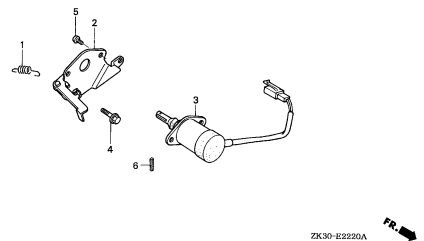

**E-23**

CONTROL BOX(1)

**2-G 8**

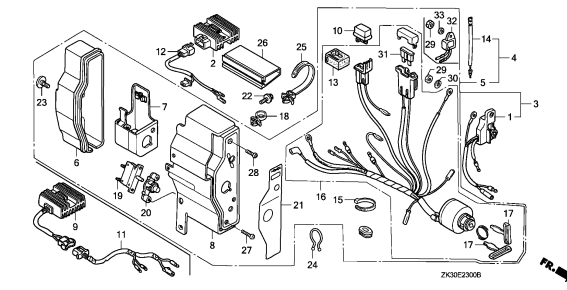

**E-23-1**

CONTROL BOX(2)

**2-G16**

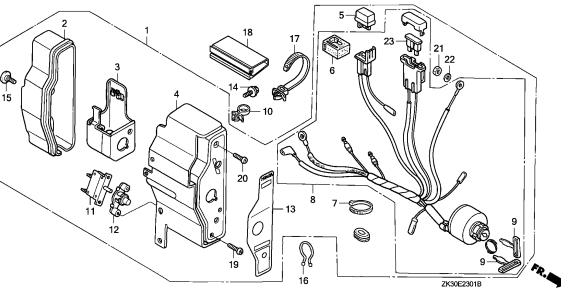

**2**

# ENGINE GROUP

**D12**

**E-23-2**

CONTROL BOX(3)

**2-H 2**

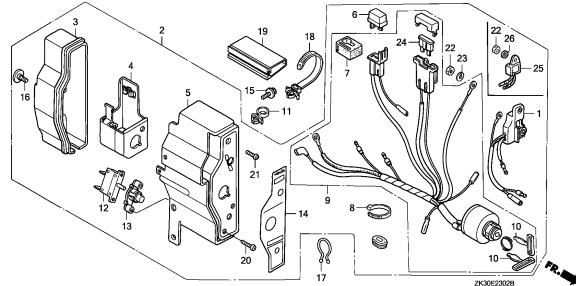

**E-23-3**

CONTROL BOX(4)

**2-H 4**

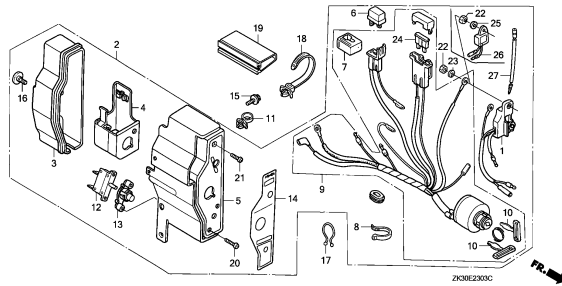

**E-23-4**

CONTROL BOX(5)

**2-H 6**

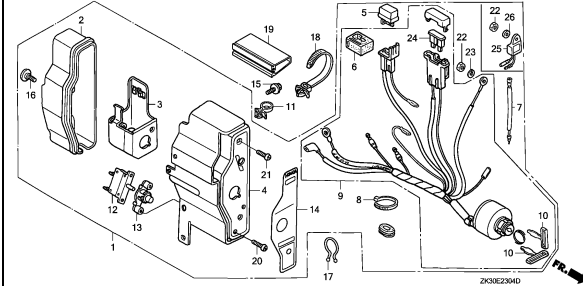

**E-23-5**

CONTROL BOX(6)

**2-H 9**

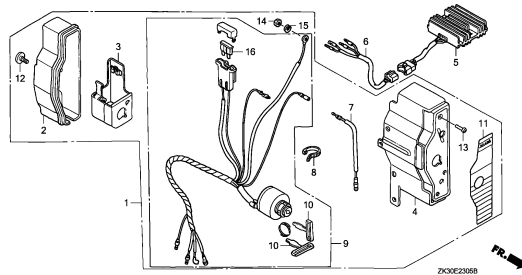

**E-23-6**

CONTROL BOX(7)

**2-H11**

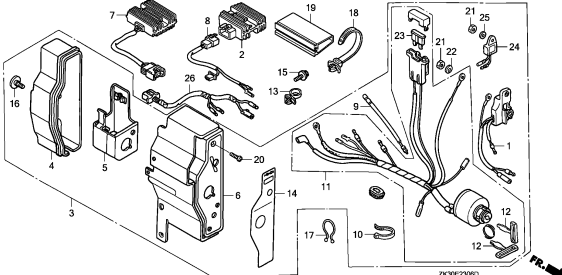

**E-23-20**

WIRE HARNESS

**2-H14**

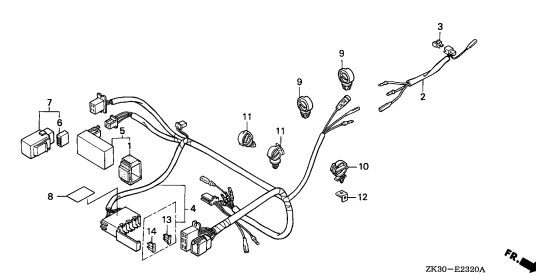

**E-25**

BATTERY(1)

**2-H15**

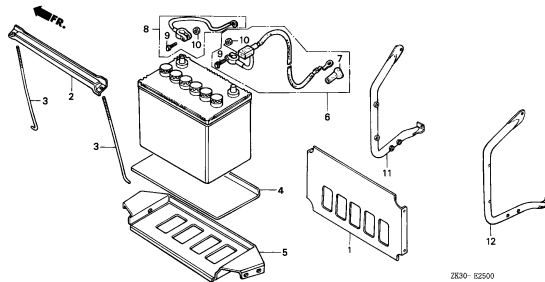

**E-25-1**

BATTERY(2)

**2-H16**

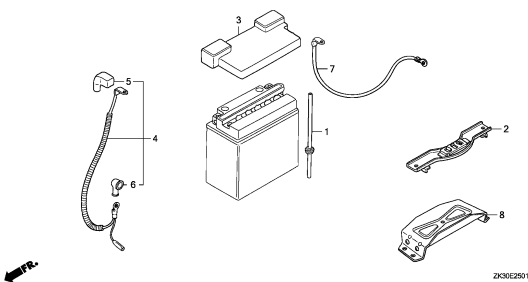

**E-26**

REDUCTION(1/2)

**2-I 1**

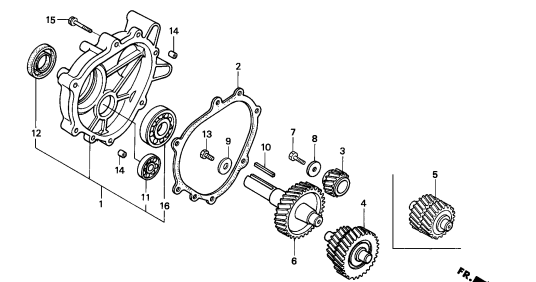

**2**



# ENGINE GROUP

**D13**

**E-26-1**

REDUCTION(1/6)

2-I 4

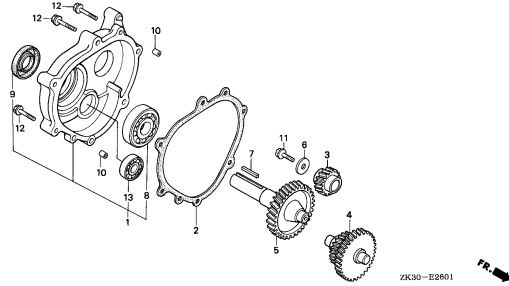

ZK30-E2601

**E-28**

LABEL(1)

2-I 5

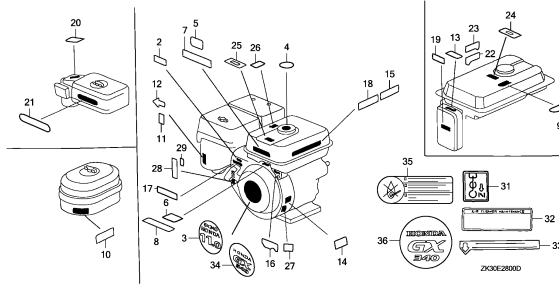

ZK30E2800

**E-28-1**

LABEL(2)

2-I12

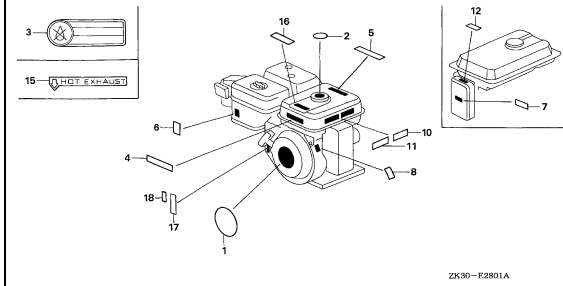

ZK30-E2801A

**E-28-2**

LABEL(3)

2-I14

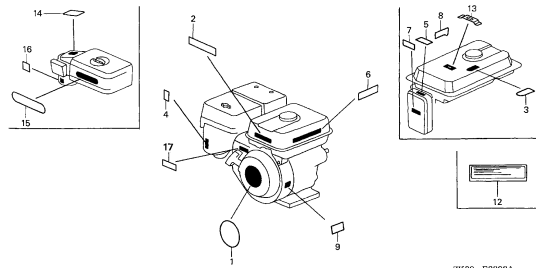

ZK30-E2802A

**E-28-3**

LABEL(4)

2-I16

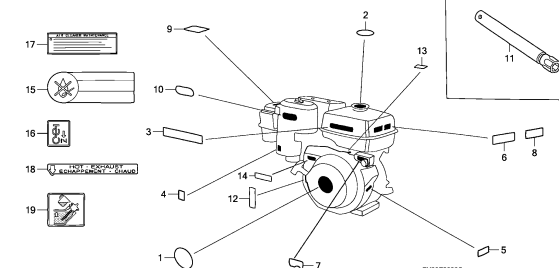

ZK30E2800C

**E-28-4**

LABEL(5)

2-J 2

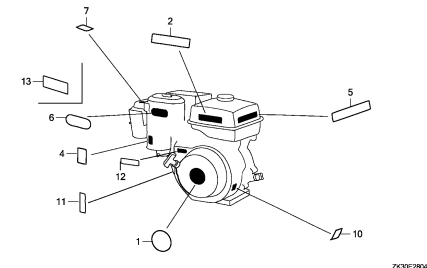

ZK30E2804C

**E-29**

TOOL(1)

2-J 4

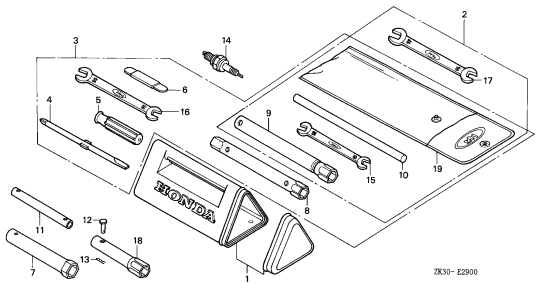

ZK30-E2900

**E-29-1**

TOOL(2)

2-J 6

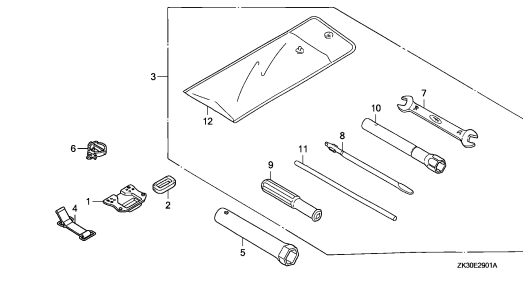

ZK30E2901A

**E-29-2**

TOOL(3)

2-J 7

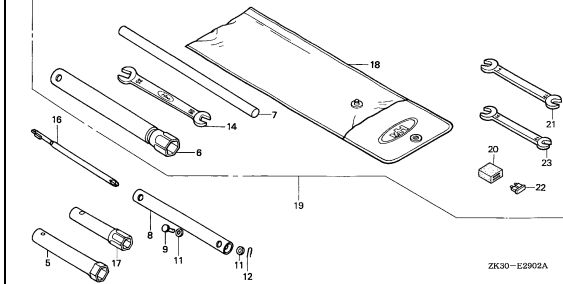

ZK30-E2902A

**2**

# ENGINE GROUP

**D14**

**E-29-3**

TOOL(4)

**2-J 8**

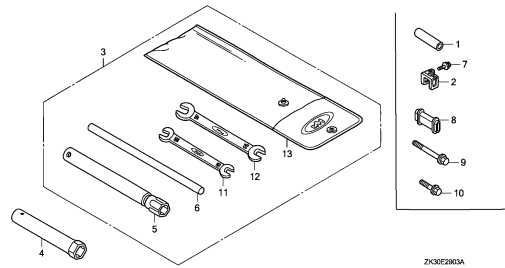

ZK30E2903A

**E-40**

CONTROL CASE

**2-J 9**

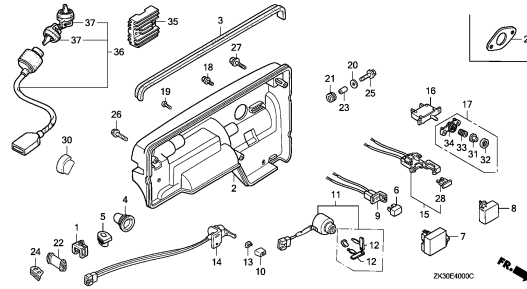

ZK30E4000C

**E-40-1**

FUEL TANK

**2-J12**

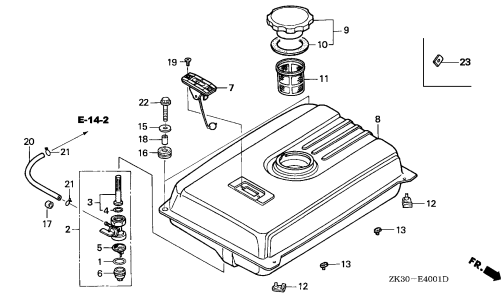

ZK30-E4001D

**E-40-2**

COMBINATION SWITCH

**2-J14**

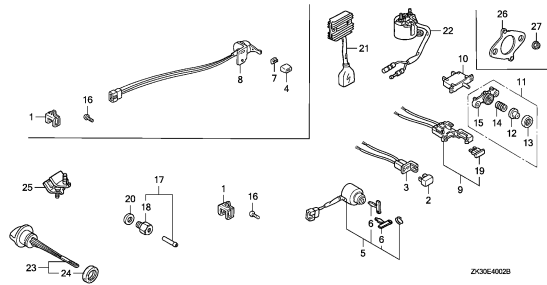

ZK30E4002B

**E-40-3**

WHEEL

**2-J16**

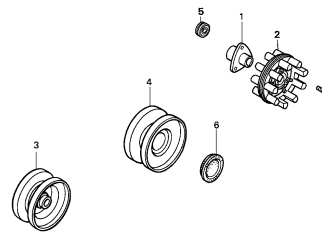

ZK30-E4003A

**E-40-4**

RECOIL STARTER

**2-K 1**

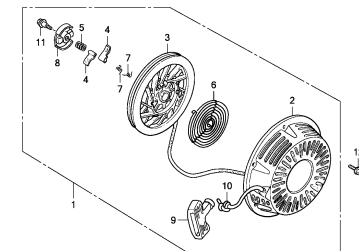

ZK30E4004

**EOP-1**

GASKET KIT

**2-K 2**

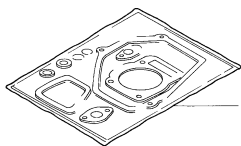

HENG-K0000

**2**

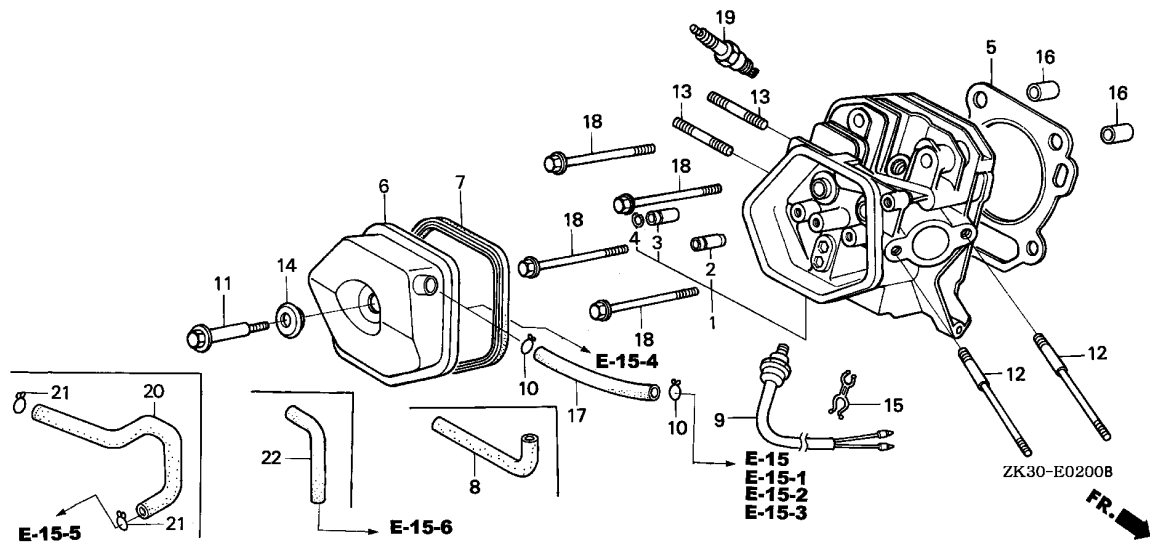

Ref. No.	L.O.N.	(Relative ref. Number) Description	F.R.T.
1	1111N3	HEAD, CYLINDER ..... .INCLUDES: Valve clearance adjustment and reface	0.9
2	1111E9	GUIDE, INTAKE VALVE ..... .INCLUDES: Valve clearance adjustment	0.8
	1111E9E	.Replace intake and exhaust all add .....	0.4
3	1111E8	GUIDE, EXHAUST VALVE ..... .INCLUDES: Valve clearance adjustment	0.8
	1111E8E	.Replace intake and exhaust all add .....	0.4
5	1111N4	GASKET, CYLINDER HEAD .....	0.5
6	1111D5	COVER, CYLINDER HEAD AND/OR PACKING, HEAD COVER .....	0.1
9	6171C4	SWITCH, CYLINDER HEAD THERMO (8,20,22)	0.2
17	1111K5	TUBE, BREATHER .....	0.1
19	6141C1	PLUG, SPARK .....	0.1

Ref. No.	Part No.	Description	Reqd. QTY GX 340K1 (1) (2) (3)	Serial No.	Parts catalogue code
1	12200-ZF6-W01	HEAD COMP., CYLINDER .....	1	-	BJ, EDE2, EDE2/A, EDN, EDN2, EDN2/A, EDN5, EDN5/A, EDS, EDS1, EDS1/A, EDS2, EDS2/A, EDS3, EDS5, EDS6, EDS6/A, EDT, EDT/A, EDT1, EDT1/A, EDT2, EDT6, EDT6/A, ED6, ED6/A, ED7, ED8, ED8/A, ED9, ED9/A, EMT, EMT/A, EN, ENT, ENT/A, ENT2, EN6, EN6/A, ES, ES1, ES1/A, ES3, ES3/A, ES4, ES4/A, ET, ETS, ETX, HA, HAQ, HA2, HA2/A, HH, HX, HX2, HX26, HX26/A, LH, LH/A, LHB1, LHB3, LHB3/A, LHB5, LHC, LHE, LHE/A, LHQ4, LHQ4/A, LHW, LJ, LJ/A, LJG, LJG/A, LJS, LJS/A, LKE, LKE/A, LP, LSX, LT, LT/A, LWD, LWD1, LWD1/A, LX, LX/A, LXE, LXE/A, LXE2, LXE2/A, LXE4, LXE4/A, LXE6, LXE8, LXE8/A, LXQ4, LXQ4/A, LXU, LXU/A, LXZ, LX2, LX2/A, LX26, LX26/A, PKT2, PKT2/A, PKT4, PKT4/A, PKX2, PKX4, PKX4/A, PX, PX/A, PXE8, PXE8/A, QA, QAB2, QAB2/A, QAC2, QAC2/A, QAE, QAE2, QAE2/A, QAE6, QAE6/A, QAG, QAG/A, QAH2, QAH2/A, QAP, QAPE, QAP2, QAP2/A, QAQ, QA2, QA2/A, QA26, QA26/A, QDW9, QDW9/A, QE, QE/A, QH, QH/A, QHB3, QHB3/A, QHB5, QHC, QHE, QHE/A, QHP1, QHP1/A, QHQ4, QHQ4/A, QH2, QKA4, QKA4/A, QL2, QMED, QMED/A, QME8, QME8/A, QMH, QMH/A, QMT2, QMT2/A, QMX2, QNE, QNE2, QNE2/A, QNE6, QNE9, QNE9/A, QNR2, QNR2/A, QNR6, QNR6/A, QN18, QP, QP/A, QPE2, QT, QT/A, QTC2, QTC2/A, QWH2, QWH2/A, QX, QX/A, QXB, QXB/A, QXB7, QXB7/A, QXC, QXC/A, QXC4, QXC4/A, QXC6, QXC6/A, QXC9, QXC9/A, QXE, QXE/A, QXEB, QXE2, QXE4, QXE4/A, QXE6, QXE6/A, QXE8, QXE8/A, QXQ4, QXQ4/A, QXU, QXU/A, QX2, SDE, SE, SE/A, SH, SH/A, SHB1, SHB3, SHB3/A, SHE, SHEZ, SHQ4, SHQ4/A, SHT, SJ, SJ/A, SJG, SJG/A, SKE, SKE/A, SKZ, SKZ/A, SME0, SME0/A, SME2, SMX2, SMX2/A, STJ, STJ/A, STP, STP/A, STQ, STQ/A, STR, STR/A, SWX, SWX/A, SX, SX/A, SXB, SXB/A, SXB7, SXB7/A, SXE, SXE/A, SXEB, SXEB/A, SXE2, SXE4, SXE4/A, SXE8, SXE8/A, SXP, SXQ4, SXQ4/A, SXU, SXU/A, VA, VAA, VAAE, VAD2, VAD2/A, VAH1, VAH2, VAW1, VA2, VA2/A, VC2, VC2/A, VDE, VDE2, VDE2/A, VD16, VE, VEB6, VH, VHE, VH12, VH12/A, VH22, VH22/A, VMT, VMT/A, VMX, VNG, VNG1, VNG2, VTE2, VMA, VMA2, VWC2, VWC2/A, VWE2, VWE2/A, VWS2, VWS2/A, VW12, VW12/A, VX, VX/A, VXA, VXB, VXB/A, VXB2, VXB7, VXB7/A, VXE, VXE/A, VXEB, VXEB/A, VXE2, VXE2/A, VXE4, VXE4/A, VXE6, VXE7, VXE7/A, VXE8, VXE8/A, VXG, VXQ4, VXQ4/A, VXU, VXU/A, VXU1, VXU1/A, VX16, VX16/A, VX8, VX8/A, YJ, ZK1, ZK1/A



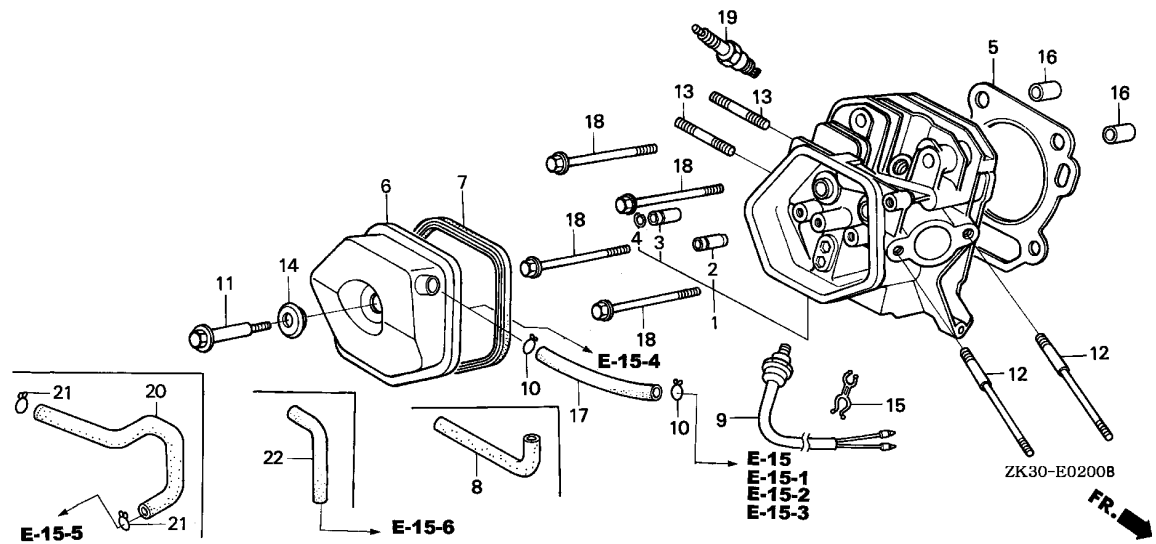

Ref. No.	Part No.	Description	Reqd. QTY			Serial No.	Parts catalogue code
			GX	340K1			
			(1)	(2)	(3)		
(1)	12200-ZF6-W01	HEAD COMP., CYLINDER .....	-	1	-		
	12200-ZF6-W11	.....	-	-	1		
	12200-ZF6-406	.....	1	-	-	-----	EDK,EDS4,EDT3,ES2,LJS1,PXA2,VMQ,VSH7,VS2,VS3,VS4,VS5,VS6,VS7,VWC,VWE,VXK
2	12204-ZE2-306	GUIDE, IN. VALVE (O.S.) .....	1	1	1		
3	12205-ZE2-305	GUIDE, EX. VALVE (O.S.) .....	1	1	1		
4	12216-ZE2-300	CLIP, VALVE GUIDE .....	1	1	1		
5	12251-ZE3-010	GASKET, CYLINDER HEAD .....	1	-	-	-----	2127684 BJ,EN,ET,ETS,ETX,LJ,LXZ,QT,SHEZ,SJ,STJ,SWX,YJ
			1	-	-	-----	2167646 LP
			-	(1)	-		

Ref. No.	Part No.	Description	Reqd. QTY			Serial No.	Parts catalogue code
			(1)	(2)	(3)		
(5)	12251-ZE3-W00	GASKET, CYLINDER HEAD .....	1	-	-	-----	EDE2,EDE2/A,EDK,EDN,EDN2,EDN2/A,EDN5,EDN5/A,EDS,EDS1,EDS1/A,EDS2,EDS2/A,EDS3,EDS4,EDS5,EDS6,EDS6/A,EDT,EDT/A,EDT1,EDT1/A,EDT2,EDT3,EDT6,EDT6/A,ED6,ED6/A,ED7,ED8,ED8/A,ED9,ED9/A,EMT,EMT/A,ENT,ENT/A,ENT2,EN6,EN6/A,ES,ES1,ES1/A,ES2,ES3,ES3/A,ES4,ES4/A,HA,HAQ,HA2,HA2/A,HH,HX,HX2,HX26,HX26/A,LH,LH/A,LHB1,LHB3,LHB3/A,LHB5,LHC,LHE,LHE/A,LHQ4,LHQ4/A,LHW,LJ/LJ/A,LJG,LJG/A,LJS,LJS/A,LJS1,LKE,LKE/A,LSX,LT,LT/A,LWD,LWD1,LWD1/A,LX,LX/A,LXE,LXE/A,LXE2,LXE2/A,LXE4,LXE4/A,LXE6,LXE8,LXE8/A,LXQ4,LXQ4/A,LXU,LXU/A,LX2,LX2/A,LX26,LX26/A,PKT2,PKT2/A,PKT4,PKT4/A,PKX2,PKX4,PKX4/A,PX,PX/A,PXA2,PXE8,PXE8/A,QA,QAB2,QAB2/A,QAC2,QAC2/A,QAE,QAE2,QAE2/A,QAE6,QAE6/A,QAG,QAG/A,QAQ2,QAQ2/A,QAP,QAPE,QAPE2,QAPE2/A,QAQ,QA2,QA2/A,QA26,QA26/A,QDW9,QDW9/A,QE,QE/A,QH,QH/A,QHB3,QHB3/A,QHB5,QHC,QHE,QHE/A,QHP1,QHP1/A,QHQ4,QHQ4/A,QHZ,QKA4,QKA4/A,QL2,QMED,QMED/A,QME8,QME8/A,QMH,QMH/A,QMT2,QMT2/A,QMX2,QNE,QNE2,QNE2/A,QNE6,QNE9,QNE9/A,QNR2,QNR2/A,QNR6,QNR6/A,QN18,QP,QP/A,QPE2,QT/QT/A,QTC2,QTC2/A,QWH2,QWH2/A,QX,QX/A,QXB,QXB/A,QXB7,QXB7/A,QXC,QXC/A,QXC4,QXC4/A,QXC6,QXC6/A,QXC9,QXC9/A,QXE,QXE/A,QXEB,QXE2,QXE4,QXE4/A,QXE6,QXE6/A,QXE8,QXE8/A,QXQ4,QXQ4/A,QXU,QXU/A,QX2,SDE,SE,SE/A,SH,SH/A,SHB1,SHB3,SHB3/A,SHE,SHQ4,SHQ4/A,SHT,SJ/A,SJG,SJG/A,SKE,SKE/A,SKZ,SKZ/A,SME0,SME0/A,SME2,SMX2,SMX2/A,STJ/A,STP,STP/A,STQ,STQ/A,STR,STR/A,SWX/A,SX,SX/A,SXB,SXB/A,SXB7,SXB7/A,SXE,SXE/A,SXEB,SXEB/A,SXE2,SXE4,SXE4/A,SXE8,SXE8/A,SXP,SXQ4,SXQ4/A,SXU,SXU/A,VA,VAA,VAAE,VAD2,VAD2/A,VAH1,VAH2,VAW1,VA2,VA2/A,VC2,VC2/A,VDE,VDE2,VDE2/A,VD16,VE,VEB6,VH,VHE,VH12,VH12/A,VH22,VH22/A,VMQ,VMT,VMT/A,VMX,VNG,VNG1,VNG2,VSH7,VS2,VS3,VS4,VS5,VS6,VS7,VTE2,VWA,VWA2,VWC,VWC2,VWC2/A,VWE,VWE2,VWE2/A,VWS2,VWS2/A,VW12,VW12/A,VX,VX/A,VXA,VXB,VXB/A,VXB2,VXB7,VXB7/A,VXE,VXE/A,VXEB,VXEB/A,VXE2,VXE2/A,VXE4,VXE6,VXE7,VXE7/A,VXE8,VXE8/A,VXG,VXK,VXQ4,VXQ4/A,VXU,VXU/A,VXU1,VXU1/A,VX16,VX16/A,VX8,VX8/A,ZK1,ZK1/A
			1	-	-	2127685 -----	BJ,EN,ET,ETS,ETX,LJ,LXZ,QT,SHEZ,SJ,STJ,SWX,YJ
			1	-	-	2167647 -----	LP
			-	(1)	1		
6	12310-ZE2-010	COVER COMP., HEAD .....	1	(1)	-	-----	2179883 BJ,EDN,EDS,ED6,ED7,ED8,ED9,EN,ES,ES1,ES3,ET,ETS,ETX,HA,HH,HX,LH,LHE,LJ,LKE,LP,LX,LXE,LXZ,L1,PX,P1,QA,QAE,QAP,QAPE,QE,QH,QHE,QNE,QP,QT,QX,QXB,QXE,QXEB,Q1,SE,SH,SHE,SHEZ,SJ,STJ,STP,STQ,SWX,SX,SXB,SXE,SXEB,SXP,S1,VA,VAA,VAAE,VAH1,VAH2,VE,VH,VHE,VNG,VNG1,VNG2,VX,VXA,VXB,VXE,VXEB,V1,YJ



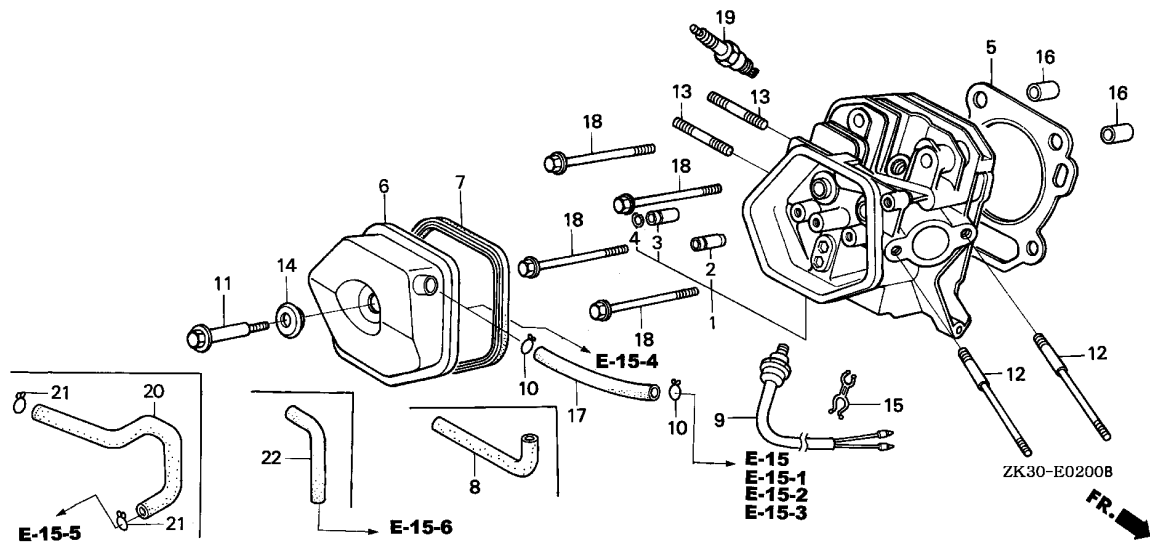

Ref. No.	Part No.	Description	Reqd. QTY			Serial No.	Parts catalogue code
			GX	(1)	(2)		
(6)	12310-ZE2-020	COVER COMP., HEAD .....	1	(1)	-	-----	EDE2,EDE2/A,EDK,EDN2,EDN2/A,EDN5,EDN5/A,EDS1,EDS1/A,EDS2,EDS2/A,EDS3,EDS4,EDS6,EDS6/A,EDT,EDT/A,EDT1,EDT1/A,EDT2,EDT3,EDT6,EDT6/A,ED6/A,ED8/A,ED9/A,EMT,EMT/A,ENT,ENT/A,ENT2,EN6,EN6/A,ES1/A,ES2,ES3/A,ES4,ES4/A,HA2,HA2/A,HX26,HX26/A,LH/A,LHB1,LHB3,LHB3/A,LHB5,LHE/A,LHQ4,LHQ4/A,LHW,LJ/A,LJG,LJG/A,LJS,LJS/A,LJS1,LKE/A,LSX,LT,LT/A,LWD,LWD1,LWD1/A,LX/A,LXE/A,LXE2,LXE2/A,LXE4,LXE4/A,LXE6,LXE8,LXE8/A,LXQ4,LXQ4/A,LXU,LXU/A,LX2,LX2/A,LX26,LX26/A,L1/A,PKT2,PKT2/A,PKT4,PKT4/A,PKX2,PKX4,PKX4/A,PX/A,PXA2,PXE8,PXE8/A,P1/A,QAB2,QAB2/A,QAC2,QAC2/A,QAE2,QAE2/A,QAE6,QAE6/A,QAG,QAG/A,QA2,QA2/A,QAP2,QAP2/A,QA2,QA2/A,QA26,QA26/A,QA26,QA26/A,QA26,QA26/A,QE/A,QH/A,QHB3,QHB3/A,QHB5,QHE/A,QHP1,QHP1/A,QHQ4,QHQ4/A,QKA4,QKA4/A,QL2,QME0,QME0/A,QME8,QME8/A,QMH,QMH/A,QMT2,QMT2/A,QMX2,QNE2,QNE2/A,QNE6,QNR2,QNR2/A,QNR6,QNR6/A,QN18,QP/A,QT/A,QTC2,QTC2/A,QX/A,QXB/A,QXB7,QXB7/A,QXE/A,QXE4,QXE4/A,QXE6,QXE6/A,QXE8,QXE8/A,QXQ4,QXQ4/A,QXU,QXU/A,Q1/A,SDE,SE/A,SH/A,SHB1,SHB3,SHB3/A,SHQ4,SHQ4/A,SJ/A,SJG,SJG/A,SKE,SKE/A,SKZ,SKZ/A,SMEO,SMEO/A,SME2,SMX2,SMX2/A,STJ/A,STP/A,STQ/A,STR,STR/A,SWX/A,SX/A,SXB/A,SXB7/A,SXB7/A,SXE/A,SXEB/A,SXE2,SXE4,SXE4/A,SXE8,SXE8/A,SXQ4,SXQ4/A,SXU,SXU/A,S1/A,VAD2,VAD2/A,VAW1,VA2,VA2/A,VC2,VC2/A,VDE,VDE2,VDE2/A,VD16,VEB6,VH12,VH12/A,VH22,VH22/A,VMQ,VMT,VMT/A,VMX,VSH7,VS2,VS3,VS4,VS5,VS6,VS7,VTE2,VWA,VWA2,VWC,VWC2,VWC2/A,VWE,VWE2,VWE2/A,VWS2,VWS2/A,VW12,VW12/A,VX/A,VXB/A,VXB2,VXB7,VXB7/A,VXE/A,VXEB/A,VXE2,VXE2/A,VXE4,VXE6,VXE7,VXE7/A,VXE8,VXE8/A,VXG,VXK,VXQ4,VXQ4/A,VXU,VXU/A,VXU1,VXU1/A,VX16,VX16/A,VX8,VX8/A

Ref. No.	Part No.	Description	Reqd. QTY			Serial No.	Parts catalogue code
			(1)	(2)	(3)		
(6)	12310-ZE2-020	COVER COMP., HEAD .....	1	(1)	-	2179884 -----	BJ,EDN,EDS,ED6,ED7,ED8,ED9,EN,ES,ES1,ES3,ET,ETS,ETX,HA,HH,HX,LH LHE,LJ,LKE,LP,LX,LXE,LXZ,L1,PX,P1,QA,QAE,QAP,QAPE,QE,QH,QHE,QNE QP,QT,QX,QXB,QXE,QXEB,Q1,SE,SH,SHE,SHEZ,SJ,STJ,STP,STQ,SWX,SX,SXB SXE,SXEB,SXP,S1,VA,VAA,VAAE,VAH1,VAH2,VE,VH,VHE,VNG,VNG1,VNG2,VX VXA,VXB,VXE,VXEB,V1,YJ
	12310-ZE3-790	COVER COMP., HEAD (BREATHER TUBE JOINT)	-	-	1		
	12310-ZE3-791	(CYCLONE) .....	1	(1)	-	2179986 -----	LHC,QHC,QXC L1,P1,Q1,S1,V1
	12310-ZE3-791	.....	1	(1)	-	2179986 -----	EDS5,HAQ,HA2,HA2/A,HX2,LX2,LX2/A,L1/A,P1/A,QAE2,QAE2/A,QAP2 QAP2/A,QAQ,QA2,QA2/A,QDW9,QDW9/A,QH2,QNE2,QNE2/A,QNE9,QNE9/A,QPE2 QWH2,QWH2/A,QXC/A,QXC4,QXC4/A,QXC6,QXC6/A,QXC9,QXC9/A,QXE2,QX2 Q1/A,SHT,S1/A,VA2,VA2/A,VWE2,VWE2/A,VXE2,VXE2/A,ZK1,ZK1/A
7	12391-ZE2-010	PACKING, HEAD COVER .....	1	(1)	-	2179987 -----	LHC,L1,P1,QHC,QXC,Q1,S1,V1
	12391-ZE2-010	.....	1	(1)	-	2179883 -----	BJ,EDN,EDS,ED6,ED7,ED8,ED9,EN,ES,ES1,ES3,ET,ETS,ETX,HA,HH,HX,LH LHE,LJ,LKE,LP,LX,LXE,LXZ,L1,PX,P1,QA,QAE,QAP,QAPE,QE,QH,QHE,QNE QP,QT,QX,QXB,QXE,QXEB,Q1,SE,SH,SHE,SHEZ,SJ,STJ,STP,STQ,SWX,SX,SXB SXE,SXEB,SXP,S1,VA,VAA,VAAE,VAH1,VAH2,VE,VH,VHE,VNG,VNG1,VNG2,VX VXA,VXB,VXE,VXEB,V1,YJ
	12391-ZE2-020	.....	1	(1)	-	2179986 -----	LHC,QHC,QXC EDE2,EDE2/A,EDK,EDN2,EDN2/A,EDN5,EDN5/A,EDS1,EDS1/A,EDS2,EDS2/A EDS3,EDS4,EDS5,EDS6,EDS6/A,EDT,EDT/A,EDT1,EDT1/A,EDT2,EDT3,EDT6 EDT6/A,ED6/A,ED8/A,ED9/A,EMT,EMT/A,ENT,ENT/A,ENT2,EN6,EN6/A,ES1/A ES2,ES3/A,ES4,ES4/A,HAQ,HA2,HA2/A,HX2,HX26,HX26/A,LH/A,LHB1,LHB3 LHB3/A,LHB5,LHE/A,LHQ4,LHQ4/A,LHW,LJ/A,LJG,LJG/A,LJS,LJS/A,LJ1 LKE/A,LSX,LT,LT/A,LWD,LWD1,LWD1/A,LX/A,LXE/A,LXE2,LXE2/A,LXE4 LXE4/A,LXE6,LXE8,LXE8/A,LXQ4,LXQ4/A,LXU,LXU/A,LX2,LX2/A,LX26 LX26/A,L1/A,PKT2,PKT2/A,PKT4,PKT4/A,PKX2,PKX4,PKX4/A,PX/A,PXA2 PX8,PX8/A,P1/A,QAB2,QAB2/A,QAC2,QAC2/A,QAE2,QAE2/A,QAE6,QAE6/A QAG,QAG/A,QA2,QA2/A,QAP2,QAP2/A,QAQ,QA2,QA2/A,QA26,QA26/A,QDW9 QDW9/A,QE/A,QH/A,QHB3,QHB3/A,QHB5,QHE/A,QHP1/A,QHQ4,QHQ4/A QH2,QKA4,QKA4/A,QL2,QMED,QMED/A,QME8,QME8/A,QMH,QMH/A,QMT2,QMT2/A QMX2,QNE2,QNE2/A,QNE6,QNE9,QNE9/A,QNR2,QNR2/A,QNR6,QNR6/A,QN18 QP/A,QPE2,QT/A,QTC2,QTC2/A,QWH2,QWH2/A,QX/A,QXB/A,QXB7,QXB7/A QXC/A,QXC4,QXC4/A,QXC6,QXC6/A,QXC9,QXC9/A,QXE/A,QXE2,QXE4,QXE4/A QXE6,QXE6/A,QXE8,QXE8/A,QXQ4,QXQ4/A,QXU,QXU/A,QX2,Q1/A,SDE,SE/A SH/A,SHB1,SHB3,SHB3/A,SHQ4,SHQ4/A,SHT,SJ/A,SJG,SJG/A,SKE,SKE/A SKZ,SKZ/A,SMEO,SMEO/A,SME2,SMX2,SMX2/A,STJ/A,STP/A,STQ/A,STR STR/A,SWX/A,SX/A,SXB/A,SXB7,SXB7/A,SXE/A,SXEB/A,SXE2,SXE4,SXE4/A SX8,SX8/A,SXQ4,SXQ4/A,SXU,SXU/A,S1/A,VAD2,VAD2/A,VAW1,VA2,VA2/A VC2,VC2/A,VDE,VDE2,VDE2/A,VD16,VEB6,VH12,VH12/A,VH22,VH22/A,VMQ VMT,VMT/A,VMX,VSH7,VS2,VS3,VS4,VS5,VS6,VS7,VTE2,VWA,VWA2,VWC,VWC2 VWC2/A,VWE,VWE2,VWE2/A,VWS2,VWS2/A,VW12,VW12/A,VX/A,VXB/A,VXB2 VXB7,VXB7/A,VXE/A,VXEB/A,VXE2,VXE2/A,VXE4,VXE6,VXE7,VXE7/A,VXE8 VXE8/A,VXG,VXK,VXQ4,VXQ4/A,VXU,VXU/A,VXU1,VXU1/A,VX16,VX16/A,VX8 VX8/A,ZK1,ZK1/A
	12391-ZE2-020	.....	1	(1)	-	2179884 -----	BJ,EDN,EDS,ED6,ED7,ED8,ED9,EN,ES,ES1,ES3,ET,ETS,ETX,HA,HH,HX,LH LHE,LJ,LKE,LP,LX,LXE,LXZ,L1,PX,P1,QA,QAE,QAP,QAPE,QE,QH,QHE,QNE QP,QT,QX,QXB,QXE,QXEB,Q1,SE,SH,SHE,SHEZ,SJ,STJ,STP,STQ,SWX,SX,SXB SXE,SXEB,SXP,S1,VA,VAA,VAAE,VAH1,VAH2,VE,VH,VHE,VNG,VNG1,VNG2,VX VXA,VXB,VXE,VXEB,V1,YJ
	12391-ZE2-020	.....	1	(1)	-	2179987 -----	LHC,QHC,QXC
8	15721-ZE3-H00	TUBE, BREATHER .....	1	-	-	-----	LP
9	16500-ZE2-702	SWITCH, THERMO .....	1	-	-	-----	EDS3,EDS5
10	17316-611-000	CLIP, BREATHER TUBE .....	2	-	-	-----	HAQ,LHC,QAQ,QDW9,QDW9/A,QHC,QNE9,QNE9/A,QWH2,QWH2/A,QXC,QXC/A QXC4,QXC4/A,QXC6,QXC6/A,QXC9,QXC9/A,SHT
			-	(2)	-		



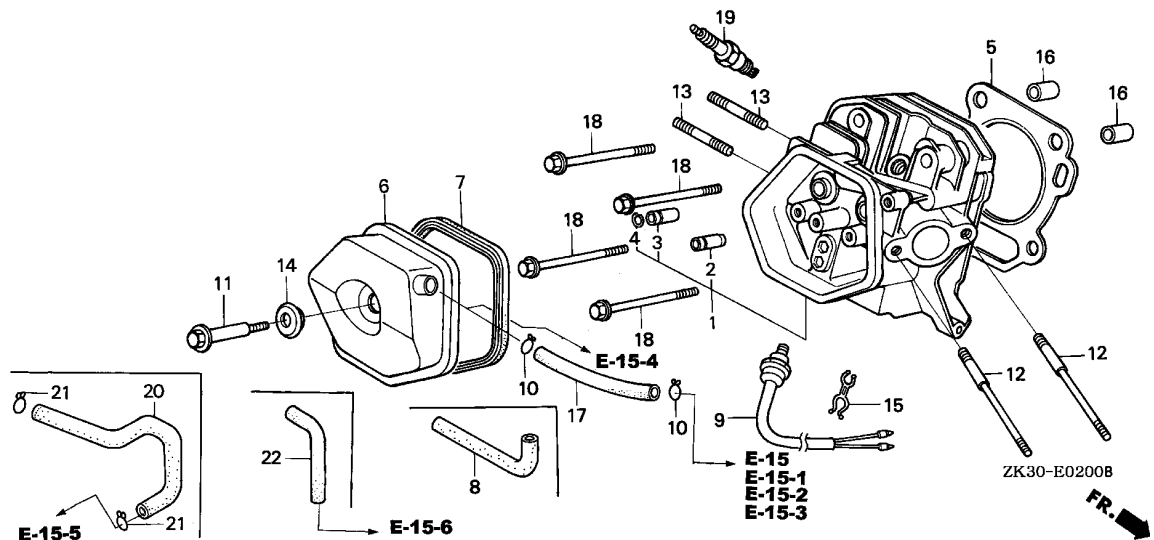

Ref. No.	Part No.	Description	Reqd. QTY			Serial No.	Parts catalogue code
			GX	(1)	(2)		
11	90014-ZE2-000	BOLT, HEAD COVER .....	1	1	1		
12	90042-ZE8-000	BOLT, STUD, 8X131.5 .....	2	-	-	-----	BJ, EDK, EDN5, EDN5/A, ED7, ED8, ED8/A, ED9, ED9/A, EN, ES, ES1, ES1/A, ES2, ET, ETS, ETX, HA, HAQ, HA2, HA2/A, HH, HX, HX2, HX26, HX26/A, LH, LH/A, LHB1, LHB3, LHB3/A, LHB5, LHC, LHE, LHE/A, LHQ4, LHQ4/A, LHW, LJ, LJ/A, LJG, LJG/A, LJS, LJS/A, LJS1, LKE, LKE/A, LSX, LT, LT/A, LWD, LWD1, LWD1/A, LX, LX/A, LXE, LXE/A, LXE2, LXE2/A, LXE4, LXE4/A, LXE6, LXE8, LXE8/A, LXQ4, LXQ4/A, LXU, LXU/A, LXZ, LXZ, LX2, LX2/A, LX26, LX26/A, PKT2, PKT2/A, PKT4, PKT4/A, PKX2, PKX4, PKX4/A, PX, PX/A, PXA2, PXE8, PXE8/A, QA, QAB2, QAB2/A, QAC2, QAC2/A, QAE, QAE2, QAE2/A, QAE6, QAE6/A, QAG, QAG/A, QAH2, QAH2/A, QAP, QAPE, QAP2, QAP2/A, QAQ, QA2, QA2/A, QA26, QA26/A, QDW9, QDW9/A, QE, QE/A, QH, QH/A, QHB3, QHB3/A, QHB5, QHC, QHE, QHE/A, QHP1, QHP1/A, QHQ4, QHQ4/A, QH2, QKA4, QKA4/A, QL2, QME0, QME0/A, QME8, QME8/A, QMH, QMH/A, QMT2, QMT2/A, QMX2, QNE, QNE2, QNE2/A, QNE6, QNE9, QNE9/A, QNR2, QNR2/A, QNR6, QNR6/A, QN18, QP, QP/A, QPE2, QT, QT/A, QTC2, QTC2/A, QWH2, QWH2/A, QX, QX/A, QXB, QXB/A, QXB7, QXB7/A, QXC, QXC/A, QXC4, QXC4/A, QXC6, QXC6/A, QXC9, QXC9/A, QXE, QXE/A, QXEB, QXE2, QXE4, QXE4/A, QXE6, QXE6/A, QXE8, QXE8/A, QXQ4, QXQ4/A, QXU, QXU/A, QX2, SDE, SE, SE/A, SH, SH/A, SHB1, SHB3, SHB3/A, SHE, SHEZ, SHQ4, SHQ4/A, SHT, SJ, SJ/A, SJG, SJG/A, SKE, SKE/A, SKZ, SKZ/A, SMEO, SMEO/A, SME2, SMX2, SMX2/A, STJ, STJ/A, STP, STP/A, STQ, STQ/A, STR, STR/A, SWX, SWX/A, SX, SX/A, SXB, SXB/A, SXB7, SXB7/A, SXE, SXE/A, SXEB, SXEB/A, SXE2, SXE4, SXE4/A, SXE8, SXE8/A, SXP, SXQ4, SXQ4/A, SXU, SXU/A, VA, VAA, VAAE, VAD2, VAD2/A, VAH1, VAH2, VAW1, VA2, VA2/A, VDE, VDE2, VDE2/A, VD16, VE, VEB6, VH, VHE, VH12, VH12/A, VH22, VH22/A, VMX, VNG, VNG1, VNG2, VSH7, VWA, VWA2, VWC2, VWC2/A, VWE2, VWE2/A, VWS2, VWS2/A, VW12, VW12/A, VX, VX/A, VXA, VXB, VXB/A, VXB2, VXB7, VXB7/A, VXE, VXE/A, VXEB, VXEB/A, VXE2, VXE2/A, VXE4, VXE6, VXE7, VXE7/A, VXE8, VXE8/A, VXG, VXX, VXQ4, VXQ4/A, VXU, VXU/A, VXU1, VXU1/A, VX16, VX16/A, VX8, VX8/A, YJ, ZK1, ZK1/A
	90042-ZE2-700	BOLT, STUD, 8X98 .....	-	2	2	-----	LP



Ref. No.	Part No.	Description	Reqd. QTY			Serial No.	Parts catalogue code
			(1)	(2)	(3)		
12)	90042-ZB7-000	BOLT, STUD, 8X111 .....	2	-	-	-----	EDS5
	90042-ZE3-700	BOLT, STUD, 8X106 .....	2	-	-	-----	EDE2,EDE2/A,EDN,EDN2,EDN2/A,EDS,EDS1,EDS1/A,EDS2,EDS2/A,EDS3,EDS4 EDS6,EDS6/A,EDT,EDT/A,EDT1,EDT1/A,EDT2,EDT3,EDT6,EDT6/A,ED6,ED6/A EMT,EMT/A,ENT,ENT/A,ENT2,EN6,EN6/A,ES3,ES3/A,ES4,ES4/A,VC2,VC2/A VMQ,VMT,VMT/A,VS2,VS3,VS4,VS5,VS6,VS7,VTE2,VWC,VWE
13	90047-ZE2-000	BOLT, STUD, 8X47 .....	2	2	-	-----	BJ,EN,ES,ET,ETS,ETX,HA,HAQ,HH,HX,LHB1,LHC,LXZ,QA,QAE,QAP,QAPE,QAQ QHC,QH2,QNE,QNE6,QXEB,QX2,SHEZ,SHT,SME2,SXE2,SXP,VA,VAA,VAE,VAH1 VAH2,VAW1,VDE,VD16,VE,VEB6,VHE,VNG,VNG1,VNG2,VTE2,VWA,VXA,VXB2 VXE6,VXG,V1,YJ
			2	2	-	3030997	EDN,EDN5,EDS,EDS3,ED7,ED8,ED9,ES1,ES3,ES4,HX26,LH,LHB3,LHE,LHQ4 LHW,LKE,LXE,LXE4,LXE6,LXE8,LXQ4,LXU,LX26,L1,PKT4,PKX4,PX,PXE8 QAE6,QA26,QE,QH,QHB3,QHE,QHP1,QHQ4,QKA4,QMEO,QME8,QMH,QNR6,QP,QT QX,QXB,QXC4,QXC6,QXE,QXE4,QXE6,QXE8,QXQ4,QXU,SE,SH,SHB1,SHB3,SHE SHQ4,SME0,SWX,SX,SXB,SXE,SXEB,SXE4,SXE8,SXQ4,SXU,VH,VMX,VX,VXB VXEB,VXE4,VXE8,VXQ4,VXU,VXU1,VX16,VX8
			2	2	-	3033461	EDE2,EDN2,EDS1,EDS2,EDT1,EDT2,ED6,HA2,HX2,LJ,LJG,LSX,LX,LXE2,LX2 PKT2,P1,QA2,QA2H,QAP2,QA2,QDW9,QMT2,QMX2,QNE2,QNR2,QN18,QPE2 QTC2,QXC,QXC9,QXE2,Q1,SDE,SJ,SJG,SKE,SKZ,SMX2,STJ,STP,STQ,STR,S1 VAD2,VA2,VDE2,VH12,VH22,VWA2,VWC2,VWE2,VWS2,VW12,VXE,VXE2
	92900-08032-0E	BOLT, STUD, 8X32 .....	2	-	-	3334263	QNE9
			2	2	-	-----	EDE2/A,EDK,EDN2/A,EDN5/A,EDS1/A,EDS2/A,EDS4,EDS6,EDS6/A,EDT,EDT/A EDT1/A,EDT3,EDT6,EDT6/A,ED6/A,ED8/A,ED9/A,EMT,EMT/A,ENT,ENT/A ENT2,EN6,EN6/A,ES1/A,ES2,ES3/A,ES4/A,HA2/A,HX26/A,LH/A,LHB3/A LHB5,LHE/A,LHQ4/A,LJ/A,LJG/A,LJS,LJS/A,LJS1,LKE/A,LT,LT/A,LWD LWD1,LWD1/A,LX/A,LXE/A,LXE2/A,LXE4/A,LXE8/A,LXQ4/A,LXU/A,LX2/A LX26/A,L1/A,PKT2/A,PKT4/A,PKX2,PKX4/A,PX/A,PXA2,PXE8/A,P1/A,QAB2 QAB2/A,QAC2,QAC2/A,QAE2/A,QAE6/A,QAG,QAG/A,QA2/A,QAP2/A,QA2/A QA26/A,QDW9/A,QE/A,QH/A,QHB3/A,QHB5,QHE/A,QHP1/A,QHQ4/A,QKA4/A QL2,QMEO/A,QME8/A,QMH/A,QMT2/A,QNE2/A,QNE9/A,QNR2/A,QNR6/A,QP/A QT/A,QTC2/A,QWH2,QWH2/A,QX/A,QXB/A,QXB7,QXB7/A,QXC/A,QXC4/A QXC6/A,QXC9/A,QXE/A,QXE4/A,QXE6/A,QXE8/A,QXQ4/A,QXU/A,Q1/A,SE/A SH/A,SHB3/A,SHQ4/A,SJ/A,SJG/A,SKE/A,SKZ/A,SME0/A,SMX2/A,STJ/A STP/A,STQ/A,STR/A,SWX/A,SX/A,SXB/A,SXB7,SXB7/A,SXE/A,SXEB/A SXE4/A,SXE8/A,SXQ4/A,SXU/A,S1/A,VAD2/A,VA2/A,VC2,VC2/A,VE2/A VH12/A,VH22/A,VMQ,VMT,VMT/A,VSH7,VS2,VS3,VS4,VS5,VS6,VS7,VWC2/A VWE2/A,VWS2/A,VW12/A,VX/A,VXB/A,VXB7,VXB7/A,VXE/A,VXEB/A,VXE2/A VXE7,VXE7/A,VXE8/A,VXK,VXQ4/A,VXU/A,VXU1/A,VX16/A,VX8/A
			2	2	-	3030998	EDN,EDN5,EDS,EDS3,ED7,ED8,ED9,ES1,ES3,ES4,HX26,LH,LHB3,LHE,LHQ4 LHW,LKE,LXE,LXE4,LXE6,LXE8,LXQ4,LXU,LX26,L1,PKT4,PKX4,PX,PXE8 QAE6,QA26,QE,QH,QHB3,QHE,QHP1,QHQ4,QKA4,QMEO,QME8,QMH,QNR6,QP,QT QX,QXB,QXC4,QXC6,QXE,QXE4,QXE6,QXE8,QXQ4,QXU,SE,SH,SHB1,SHB3,SHE SHQ4,SME0,SWX,SX,SXB,SXE,SXEB,SXE4,SXE8,SXQ4,SXU,VH,VMX,VX,VXB VXEB,VXE4,VXE8,VXQ4,VXU,VXU1,VX16,VX8
			2	2	-	3033462	EDE2,EDN2,EDS1,EDS2,EDT1,EDT2,ED6,HA2,HX2,LJ,LJG,LSX,LX,LXE2,LX2 PKT2,P1,QA2,QA2H,QAP2,QA2,QDW9,QMT2,QMX2,QNE2,QNR2,QN18,QPE2 QTC2,QXC,QXC9,QXE2,Q1,SDE,SJ,SJG,SKE,SKZ,SMX2,STJ,STP,STQ,STR,S1 VAD2,VA2,VDE2,VH12,VH22,VWA2,VWC2,VWE2,VWS2,VW12,VXE,VXE2
			2	-	-	3334264	QNE9
	92900-08022-0B	BOLT, STUD, 8X22 .....	2	-	-	-----	ZK1,ZK1/A
	90012-KM9-000	BOLT, STUD, 8X34 .....	2	-	-	-----	EDS5,LP
	90047-ZE3-791	BOLT, STUD, 8X40 .....	2	-	-	-----	VWC,VWE
14	90441-ZE2-010	WASHER COMP., HEAD COVER .....	1	1	1	-----	EDS3
15	90658-SA0-003	CLIP, WIRE HARNESS .....	1	-	-	-----	
16	94301-12200	DOWEL PIN, 12X20 .....	2	2	2	-----	



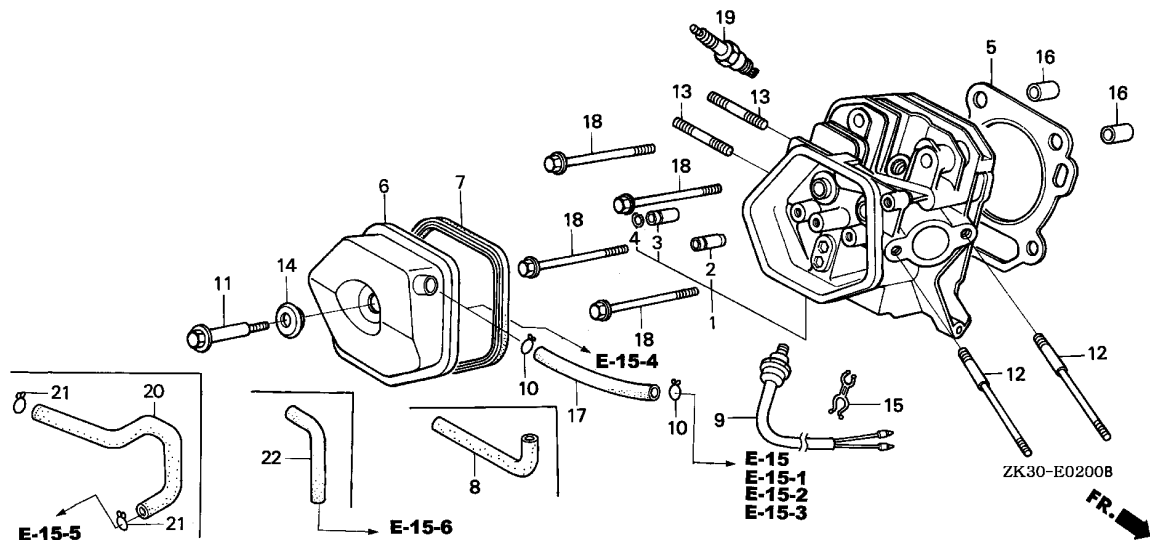

Ref. No.	Part No.	Description	Reqd. QTY			Serial No.	Parts catalogue code
			GX	340K1	(3)		
17	95005-11105-30	TUBE, 11X105(95005-11001-30M)	1	-	-	-----	BJ,EDK,EDN5,EDN5/A,EDT2,ED7,ED8,ED8/A,ED9,ED9/A,EN,ES,ES1,ES1/A,ES2,ET,ETS,ETX,HA,HA2,HA2/A,HH,HX,HX26,HX26/A,LH,LH/A,LHB1,LHB3,LHB3/A,LHB5,LHE,LHE/A,LHQ4,LHQ4/A,LHW,LJ,LJ/A,LJG,LJG/A,LJS,LJS/A,LJS1,LKE,LKE/A,LSX,LT,LT/A,LWD,LX,LX/A,LXE,LXE/A,LXE2,LXE2/A,LXE4,LXE4/A,LXE6,LXE8,LXE8/A,LXQ4,LXQ4/A,LXU,LXU/A,LXZ,LX2,LX2/A,LX26,LX26/A,PKT2,PKT2/A,PKT4,PKT4/A,PKX2,PKX4,PKX4/A,PX,PX/A,PXA2,PXE8,PXE8/A,QA,QAB2,QAB2/A,QAC2,QAC2/A,QAE,QAE2,QAE2/A,QAE6,QAE6/A,QAG,QAG/A,QA2,QA2/A,QAH2,QA2/A,QAP,QAPE,QAP2,QAP2/A,QA2,QA2/A,QA26,QA26/A,QE,QE/A,QH,QH/A,QHB3,QHB3/A,QHB5,QHE,QHE/A,QHP1,QHP1/A,QHQ4,QHQ4/A,QKA4,QKA4/A,QL2,QMED,QMED/A,QME8,QME8/A,QMH,QMH/A,QMT2,QMT2/A,QMX2,QNE,QNE2,QNE2/A,QNE6,QNR2,QNR2/A,QNR6,QNR6/A,QN18,QP,QP/A,QT,QT/A,QTC2,QTC2/A,QX,QX/A,QXB,QXB/A,QXB7,QXB7/A,QXE,QXE/A,QXEB,QXE4,QXE4/A,QXE6,QXE6/A,QXE8,QXE8/A,QXQ4,QXQ4/A,QXU,QXU/A,SDE,SE,SE/A,SH,SH/A,SHB1,SHB3,SHB3/A,SHE,SHEZ,SHQ4,SHQ4/A,SJ,SJ/A,SJG,SJG/A,SKE,SKE/A,SKZ,SKZ/A,SME0,SME0/A,SME2,SMX2,SMX2/A,STJ,STJ/A,STP,STP/A,STQ,STQ/A,STR,STR/A,SWX,SWX/A,SX,SX/A,SBX,SBX/A,SBX7,SBX7/A,SXE,SXE/A,SXEB,SXEB/A,SXE2,SXE4,SXE4/A,SXEB,SXE8/A,SXP,SXQ4,SXQ4/A,SXU,SXU/A,VA,VAA,VAAE,VAD2,VAD2/A,VAH1,VAH2,VAW1,VA2,VA2/A,VDE,VDE2,VDE2/A,VD16,VE,VEB6,VH,VHE,VH12,VH12/A,VH22,VH22/A,VMX,VNG,VNG1,VNG2,VSH7,VWA,VWA2,VWC2,VWC2/A,VWE2,VWE2/A,VWS2,VWS2/A,VW12,VW12/A,VX,VX/A,VXA,VXB,VXB/A,VXB2,VXB7,VXB7/A,VXE,VXE/A,VXEB,VXEB/A,VXE2,VXE2/A,VXE4,VXE6,VXE7,VXE7/A,VXE8,VXE8/A,VXG,VXK,VXQ4,VXQ4/A,VXU,VXU/A,VXU1,VXU1/A,VX16,VX16/A,VX8,VX8/A,YJ
	12315-ZE3-840	TUBE, BREATHER .....	1	-	-	-----	HAQ,HX2,LHC,QAQ,QDW9,QDW9/A,QHC,QH2,QNE9,QNE9/A,QPE2,QWH2,QWH2/A,QXC,QXC/A,QXC4,QXC4/A,QXC6,QXC6/A,QXC9,QXC9/A,QXE2,QX2,SHT

Ref. No.	Part No.	Description	Reqd. QTY			Serial No.	Parts catalogue code
			(1)	(2)	(3)		
18	95725-10080-00	BOLT, FLANGE, 10X80 .....	4	4	-	-----	BJ, EDE2, EDE2/A, EDN, EDN2, EDN2/A, EDN5, EDS, EDS1, EDS2, EDS2/A, EDS3, EDS5, EDS6, EDS6/A, EDT, EDT/A, EDT1, EDT2, EDT6, EDT6/A, ED6, ED6/A, ED7, ED8, ED9, EMT, EN, ENT, ENT/A, ENT2, EN6, EN6/A, ES, ES1, ES3, ES4, ET, ETS, ETX, HA, HAQ, HA2, HA2/A, HH, HX, HX2, HX26, HX26/A, LH, LHB1, LHB3, LHC, LHE, LHQ4, LHQ4/A, LHW, LJ, LJG, LJS, LKE, LKE/A, LP, LSX, LT, LWD1, LX, LXE, LXE2, LXE2/A, LXE4, LXE4/A, LXE6, LXE8, LXE8/A, LXQ4, LXQ4/A, LXU, LXU/A, LXZ, LX2, LX2/A, LX26, LX26/A, L1, PKT2, PKT2/A, PKT4, PKT4/A, PKX2, PKX4, PKX4/A, PX, PXA2, PXE8, PXE8/A, P1, QA, QAB2, QAB2/A, QAC2, QAC2/A, QAE, QAE2, QAE2/A, QAE6, QAE6/A, QAG, QAG/A, QAH2, QAH2/A, QAP, QAPE, QAP2, QAP2/A, QAQ, QA2, QA2/A, QA26, QA26/A, QDW9, QDW9/A, QE, QE/A, QH, QHB3, QHC, QHE, QHE/A, QHP1, QHQ4, QHQ4/A, QH2, QKA4, QKA4/A, QL2, QMEO, QMEO/A, QME8, QME8/A, QMH, QMT2, QMT2/A, QMX2, QNE, QNE2, QNE2/A, QNE6, QNE9, QNE9/A, QNR2, QNR2/A, QNR6, QNR6/A, QN18, QP, QPE2, QT, QTC2, QTC2/A, QWH2, QWH2/A, QX, QXB, QXB/A, QXB7, QXB7/A, QXC, QXC4, QXC4/A, QXC6, QXC6/A, QXC9, QXC9/A, QXE, QXEB, QXE2, QXE4, QXE4/A, QXE6, QXE6/A, QXE8, QXE8/A, QXQ4, QXQ4/A, QXU, QXU/A, QX2, Q1, SDE, SE, SE/A, SH, SHB1, SHB3, SHB3/A, SHE, SHEZ, SHQ4, SHQ4/A, SHT, SJ, SJG, SKE, SKZ, SMEO, SMEO/A, SME2, SMX2, SMX2/A, STJ, STP, STQ, STR, SWX, SWX/A, SX, SXB, SXB/A, SXB7, SXB7/A, SXE, SXEB, SXEB/A, SXE2, SXE4, SXE4/A, SXE8, SXE8/A, SXP, SXQ4, SXQ4/A, SXU, SXU/A, S1, VA, VAA, VAAE, VAD2, VAD2/A, VAH1, VAH2, VAW1, VA2, VA2/A, VC2, VC2/A, VDE, VDE2, VDE2/A, VD16, VE, VEB6, VH, VHE, VH12, VH12/A, VH22, VH22/A, VMT, VMX, VNG, VNG1, VNG2, VSH7, VTE2, VVA, VWA2, VWC, VWC2, VWC2/A, VWE, VWE2, VWE2/A, VWS2, VWS2/A, VW12, VW12/A, VX, VXA, VXB, VXB/A, VXB2, VXB7, VXB7/A, VXE, VXEB, VXE2, VXE2/A, VXE4, VXE6, VXE7, VXE7/A, VXE8, VXE8/A, VXG, VXQ4, VXQ4/A, VXU, VXU1, VX16, VX16/A, VXR, VXR/A, V1, YJ, ZK1, ZK1/A
			4	4	-	4072354	EDK, EDN5/A, EDS1/A, EDS4, EDT1/A, ED8/A, ED9/A, EMT/A, ES1/A, ES3/A, ES4/A, LH/A, LHB3/A, LHB5, LHE/A, LJ/A, LJG/A, LJS/A, LJS1, LT/A, LWD, LWD1/A, LX/A, LXE/A, L1/A, PX/A, P1/A, QH/A, QHB3/A, QHB5, QHP1/A, QMH/A, QP/A, QT/A, QX/A, QXC/A, QXE/A, Q1/A, SH/A, SJ/A, SJG/A, SKE/A, SKZ/A, STJ/A, STP/A, STQ/A, STR/A, SX/A, SXE/A, S1/A, VMQ, VMT/A, VS3, VS4, VS5, VS6, VX/A, VXE/A, VXEB/A, VVK, VXU/A, VXU1/A
	95701-10080-00	.....	-	-	4		
			4	4	-	4072355	EDK, EDN5/A, EDS1/A, EDS4, EDT1/A, ED8/A, ED9/A, EMT/A, ES1/A, ES3/A, ES4/A, LH/A, LHB3/A, LHB5, LHE/A, LJ/A, LJG/A, LJS/A, LJS1, LT/A, LWD, LWD1/A, LX/A, LXE/A, L1/A, PX/A, P1/A, QH/A, QHB3/A, QHB5, QHP1/A, QMH/A, QP/A, QT/A, QX/A, QXC/A, QXE/A, Q1/A, SH/A, SJ/A, SJG/A, SKE/A, SKZ/A, STJ/A, STP/A, STQ/A, STR/A, SX/A, SXE/A, S1/A, VMQ, VMT/A, VS3, VS4, VS5, VS6, VX/A, VXE/A, VXEB/A, VVK, VXU/A, VXU1/A
19	98079-55154	PLUG, SPARK (W16EP-U11) .....	4	-	-	-----	EDT3, ES2, VS2, VS7
	98079-55841	PLUG, SPARK (BP5ES) (NGK) .....	(1)	-	-	-----	BJ, LJ, LJ/A, SJ, SJ/A, STJ, STJ/A, YJ
			1	-	-	-----	ES3/A, ES4/A
			1	-	-	2582677	ES3, ES4
			(1)	(1)	-	-----	BJ, EN, ES, ES1/A, ET, ETS, ETX, LP, LSX, LT, LT/A, LWD, L1, L1/A, P1, P1/A, Q1, Q1/A, STJ, STJ/A, STR, STR/A, S1, S1/A, YJ
			(1)	-	-	2582677	ES1
			(1)	-	-	3032023	EDN5, LJ, LJG, QMEO, SJ, SJG, SKE, SKZ, SMEO



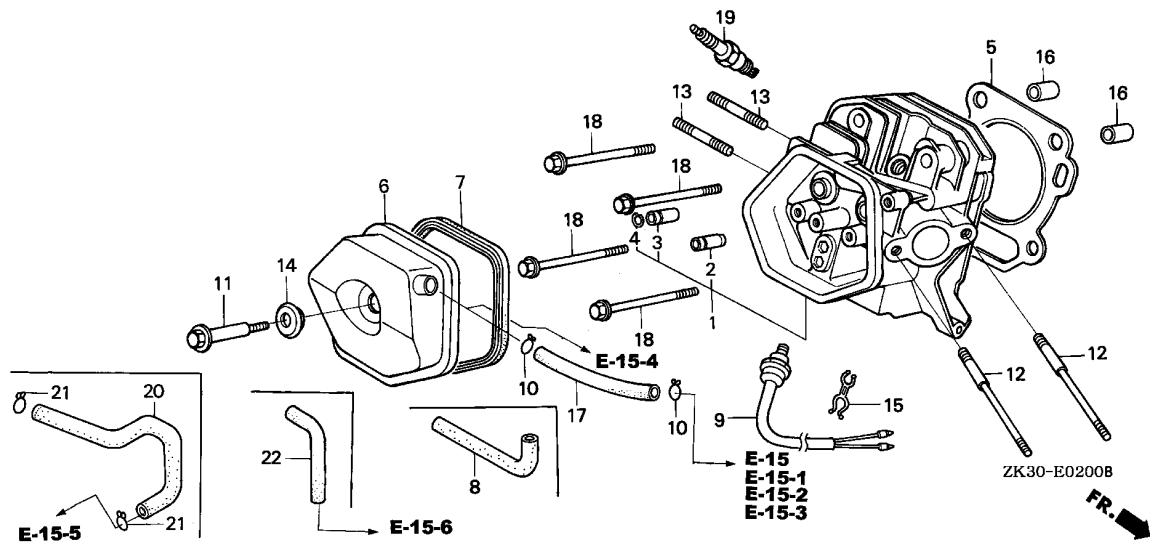

Ref. No.	Part No.	Description	Reqd. QTY			Serial No.	Parts catalogue code
			GX	(1)	(2)		
19)	98079-55846	PLUG, SPARK (BPR5ES)(NGK) ...	1	-	-	-----	EDN,EDS,EDS1,EDS1/A,EDS2,EDS2/A,EDS3,EDS4,EDS5,EDT,EDT/A,EDT1,EDT1/A,EDT2,EDT3,EMT,EMT/A,ENT,ENT/A,ENT2,EN6,EN6/A,LWD1,LWD1/A,SHT,STR,STR/A,VC2,VC2/A,VMQ,VMT,VMT/A,VS2,VS3,VS4,VS5,VS6,VS7,VTE2,VVC,VVE

Ref. No.	Part No.	Description	Reqd. QTY			Serial No.	Parts catalogue code
			(1)	(2)	(3)		
19)	98079-55846	PLUG, SPARK (BPR5ES)(NGK) ...	1	-	-	2582676	ES3,ES4
			(1)	-	-	-----	-----
			(1)	-	-	-----	-----
							EDE2, EDE2/A, EDK, EDN2, EDN2/A, EDN5/A, EDS6, EDS6/A, EDT6, EDT6/A, ED6 ED6/A, ED7, ED8, ED8/A, ED9, ED9/A, ES2, HA, HAQ, HA2, HA2/A, HH, HX, HX2, HX26 HX26/A, LH, LH/A, LHB1, LHB3, LHB3/A, LHB5, LHC, LHE, LHE/A, LHQ4, LHQ4/A LHW, LJ/A, LJG/A, LJS, LJS/A, LJS1, LKE, LKE/A, LX, LX/A, LXE, LXE/A, LXE2 LXE2/A, LXE4, LXE4/A, LXE6, LXE8, LXE8/A, LXQ4, LXQ4/A, LXU, LXU/A, LXZ, LXZ LX2/A, LX26, LX26/A, PKT2, PKT2/A, PKT4, PKT4/A, PKX2, PKX4, PKX4/A, PX PX/A, PXA2, PXE8, PXE8/A, QA, QAB2, QAB2/A, QAC2, QAC2/A, QAE, QAE2, QAE2/A QAE6, QAE6/A, QAG, QAG/A, QAH2, QAH2/A, QAP, QAPE, QAP2, QAP2/A, QAQ, QAZ QAZ/A, QA26, QA26/A, QDW9, QDW9/A, QE, QE/A, QH, QH/A, QHB3, QHB3/A, QHB5 QHC, QHE, QHE/A, QHP1, QHP1/A, QHQ4, QHQ4/A, QH2, QKA4, QKA4/A, QL2, QMEO/A QME8, QME8/A, QMH, QMH/A, QMT2, QMT2/A, QMX2, QNE, QNE2, QNE2/A, QNE6, QNE9 QNE9/A, QNR2, QNR2/A, QNR6, QNR6/A, QN18, QP, QP/A, QPE2, QTC2, QTC2/A, QWH2 QWH2/A, QX, QX/A, QXB, QXB/A, QXB7, QXB7/A, QXC, QXC/A, QXC4, QXC4/A, QXC6 QXC6/A, QXC9, QXC9/A, QXE, QXE/A, QXEB, QXE2, QXE4, QXE4/A, QXE6, QXE6/A QXE8, QXE8/A, QXQ4, QXQ4/A, QXU, QXU/A, QX2, SDE, SE, SE/A, SH, SH/A, SHB1 SHB3, SHB3/A, SHE, SHEZ, SHQ4, SHQ4/A, SJ/A, SJG/A, SKE/A, SKZ/A, SMEO/A SME2, SMX2, SMX2/A, STP, STP/A, STQ, STQ/A, SWX, SWX/A, SX, SX/A, SXB, SXB/A SXB7, SXB7/A, SXE, SXE/A, SXEB, SXEB/A, SXE2, SXE4, SXE4/A, SXE8, SXE8/A SXP, SXQ4, SXQ4/A, SXU, SXU/A, VA, VAA, VAAE, VAD2, VAD2/A, VAH1, VAH2, VAW1 VA2, VA2/A, VDE, VDE2, VDE2/A, VD16, VE, VEB6, VH, VHE, VH12, VH12/A, VH22 VH22/A, VMX, VNG, VNG1, VNG2, VSH7, VWA, VWA2, VWC2, VWC2/A, VWE2, VWE2/A VWS2, VWS2/A, VW12, VW12/A, VX, VX/A, VXA, VXB, VXB/A, VXB2, VXB7, VXB7/A VXE, VXE/A, VXEB, VXEB/A, VXE2, VXE2/A, VXE4, VXE6, VXE7, VXE7/A, VXE8 VXE8/A, VXG, VXC, VXQ4, VXQ4/A, VXU, VXU/A, VXU1, VXU1/A, VX16, VX16/A, VX8 VX8/A (1) - - 3032024 ----- EDN5, LJ, LJG, QMEO, SJ, SJG, SKE, SKZ, SMEO (1) - - ----- 2582676 ES1 - (1) (1) 1 - - ----- ES3/A, ES4/A 1 - - 2582677 ----- ES3, ES4 (1) - - ----- BJ, EN, ES, ES1/A, ET, ETS, ETX, LP, LSX, LT, LT/A, LWD, QT, QT/A, STJ, STJ/A STR, STR/A, YJ (1) - - 2582677 ----- ES1 (1) - - ----- 3032023 EDN5, LJ, LJG, SJ, SJG, SKE, SKZ - (1) -
	98079-55854	PLUG, SPARK (W16EP-U)(DENSO)	1	-	-		
			(1)	-	-		
			(1)	-	-		



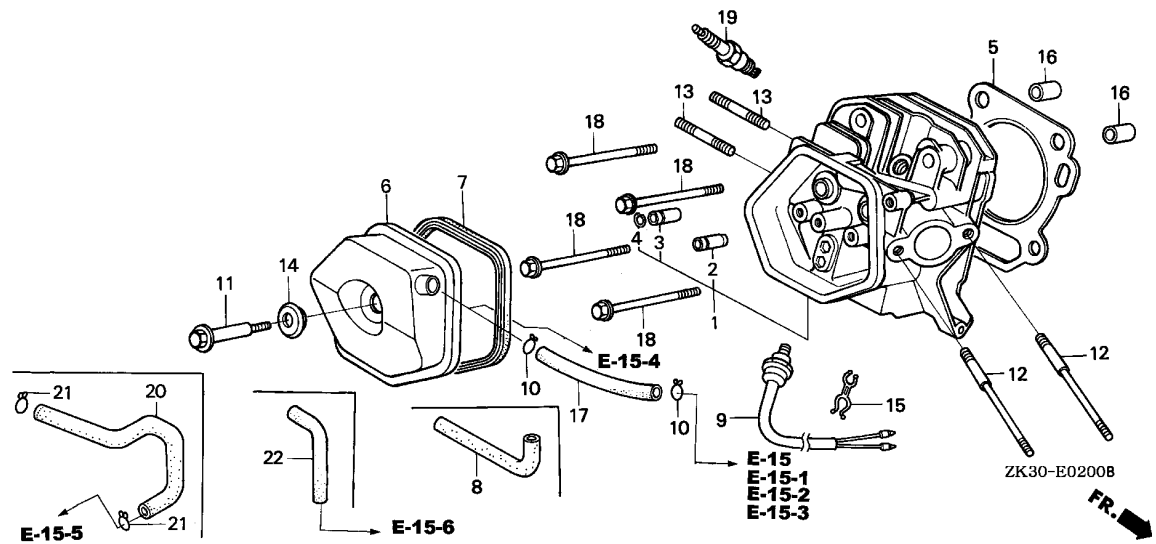

Ref. No.	Part No.	Description	Reqd. QTY			Serial No.	Parts catalogue code
			GX	(1)	(2)		
19)	98079-55855	PLUG, SPARK (W16EPR-U) (DENSO)	1	-	-	-----	EDE2,EDE2/A,EDN,EDN2,EDN2/A,EDS,EDS1,EDS1/A,EDS2,EDS2/A,EDS3,EDS4,EDS5,EDS6,EDS6/A,EDT,EDT/A,EDT1,EDT1/A,EDT2,EDT3,EDT6,EDT6/A,ED6,ED6/A,EMT,EMT/A,ENT,ENT/A,ENT2,EN6,EN6/A,LWD1,LWD1/A,SHT,STR,STR/A,VC2,VC2/A,VMQ,VMT,VMT/A,VS2,VS3,VS4,VS5,VS6,VS7,VTE2,VWC,VWE

Ref. No.	Part No.	Description	Reqd. QTY			Serial No.	Parts catalogue code
			(1)	(2)	(3)		
19)	98079-55855	PLUG, SPARK (W16EPR-U) (DENSO)	1	-	-	2582676	ES3,ES4
			(1)	-	-	-----	EDK,EDN5/A,ED7,ED8,ED8/A,ED9,ED9/A,ES2,HH,HX,HX2,HX26,HX26/A,LH
			(1)	-	-	-----	LH/A,LHB1,LHB3,LHB3/A,LHB5,LHC,LHE,LHE/A,LHQ4,LHQ4/A,LHW,LJ/A
							LJG/A,LJS,LJS/A,LJS1,LKE,LKE/A,LX,LX/A,LXE,LXE/A,LXE2,LXE2/A,LXE4
							LXE4/A,LXE6,LXE8,LXE8/A,LXQ4,LXQ4/A,LXU,LXU/A,LXZ,LX2,LX2/A,LX26
							LX26/A,PKT2,PKT2/A,PKT4,PKT4/A,PKX2,PKX4,PKX4/A,PX,PX/A,PXA2,PXE8
							PXE8/A,QA,QAB2,QAB2/A,QAC2,QAC2/A,QAE,QAE2,QAE2/A,QAE6,QAE6/A,QAG
							QAG/A,QAQ2,QAQ2/A,QAP,QAPE,QAP2,QAP2/A,QAQ,QA2,QA2/A,QA26,QA26/A
							QDW9,QDW9/A,QE,QE/A,QH,QH/A,QHB3,QHB3/A,QHB5,QHC,QHE,QHE/A,QHP1
							QHP1/A,QHQ4,QHQ4/A,QH2,QKA4,QKA4/A,QL2,QMEO,QMEO/A,QME8,QME8/A
							QMH,QMH/A,QMT2,QMT2/A,QMX2,QNE,QNE2,QNE2/A,QNE6,QNE9,QNE9/A,QNR2
							QNR2/A,QNR6,QNR6/A,QN18,QP,QP/A,QPE2,QTC2,QTC2/A,QWH2,QWH2/A,QX
							QX/A,QXB,QXB/A,QXB7,QXB7/A,QXC,QXC/A,QXC4,QXC4/A,QXC6,QXC6/A,QXC9
							QXC9/A,QXE,QXE/A,QXEB,QXE2,QXE4,QXE4/A,QXE6,QXE6/A,QXE8,QXE8/A
							QXQ4,QXQ4/A,QXU,QXU/A,QX2,SDE,SE,SE/A,SH,SH/A,SHB1,SHB3,SHB3/A
							SHE,SHEZ,SHQ4,SHQ4/A,SJ/A,SJG/A,SKE/A,SKZ/A,SMEO,SMEO/A,SME2,SMX2
							SMX2/A,STP,STP/A,STQ,STQ/A,SX,SX/A,SXB,SXB/A,SXB7,SXB7/A,SXE
							SXE/A,SXEB,SXEB/A,SXE2,SXE4,SXE4/A,SXE8,SXE8/A,SXP,SXQ4,SXQ4/A
							SXU,SXU/A,VA,VAA,VAAE,VAD2,VAD2/A,VAH1,VAH2,VAW1,VA2,VA2/A,VDE
							VDE2,VDE2/A,VD16,VE,VEB6,VH,VHE,VH12,VH12/A,VH22,VH22/A,VMX,VNG
							VNG1,VNG2,VSH7,VWA,VWA2,VWC2,VWC2/A,VWE2,VWE2/A,VWS2,VWS2/A,VW12
							VW12/A,VX,VX/A,VXA,VXB,VXB/A,VXB2,VXB7,VXB7/A,VXE,VXE/A,VXEB
							VXEB/A,VXE2,VXE2/A,VXE4,VXE6,VXE7,VXE7/A,VXE8,VXE8/A,VXG,VXK,VXQ4
							VXQ4/A,VXU,VXU/A,VXU1,VXU1/A,VX16,VX16/A,VX8,VX8/A
			(1)	-	-	3032024	-----
			(1)	-	-	2582676	ES1
			-	(1)	(1)		
	98079-56841	PLUG, SPARK (BP6ES) (NGK) .....	1	-	-	-----	BJ,EN,ES,ES1/A,ET,ETS,ETX,LP,LSX,LT,LT/A,LWD,STJ,STJ/A,YJ
			1	-	-	2427099	-----
			1	-	-	2593056	-----
			1	-	-	-----	ES1
			1	-	-	3032023	EDN5,LJ,LJG,QHB3,SDE,SJ,SJG,SKE,SKZ
			-	(1)	-		



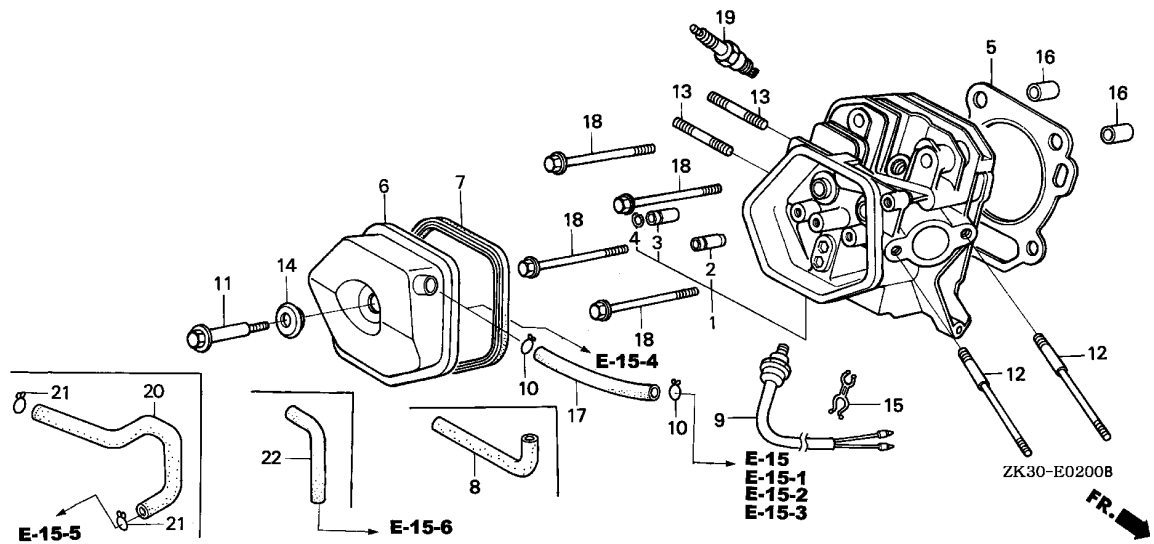

Ref. No.	Part No.	Description	Reqd. QTY			Serial No.	Parts catalogue code
			GX	(1)	(2)		
19)	98079-56846	PLUG, SPARK (BPR6ES)(NGK) ...	1	-	-	-----	EDK,EDN5/A,ED7,ED8,ED8/A,ED9,ED9/A,ES2,HA,HAQ,HA2,HA2/A,HH,HX,HX2 HX26,HX26/A,LH,LH/A,LHB3,LHB3/A,LHB5,LHC,LHE,LHE/A,LHQ4,LHQ4/A LHW,LJ/A,LJG/A,LJS,LJS/A,LJS1,LKE,LKE/A,LX,LX/A,LXE,LXE/A,LXE2 LXE2/A,LXE4,LXE4/A,LXE6,LXE8,LXE8/A,LXQ4,LXQ4/A,LXU,LXU/A,LXZ,LXZ LX2/A,LX26,LX26/A,PKT2,PKT2/A,PKT4,PKT4/A,PKX2,PKX4,PKX4/A,PX PX/A,PXA2,PXE8,PXE8/A,QA,QAB2,QAB2/A,QAC2,QAC2/A,QAE,QAE2,QAE2/A QAE6,QAE6/A,QAG,QAG/A,QA2,QA2/A,QAH2,QAH2/A,QAP,QAPE,QAP2,QAP2/A,QAQ,QA2 QA2/A,QA26,QA26/A,QDW9,QDW9/A,QE,QE/A,QH,QH/A,QHB3/A,QHB5,QHC,QHE QHE/A,QHP1,QHP1/A,QHQ4,QHQ4/A,QH2,QKA4,QKA4/A,QL2,QMEO,QMEO/A QME8,QME8/A,QMH,QMH/A,QMT2,QMT2/A,QMX2,QNE,QNE2,QNE2/A,QNE6,QNE9 QNE9/A,QNR2,QNR2/A,QNR6,QNR6/A,QN18,QP,QP/A,QPE2,QTC2,QTC2/A,QWH2 QWH2/A,QX,QX/A,QXB,QXB/A,QXB7,QXB7/A,QXC,QXC/A,QXC4,QXC4/A,QXC6 QXC6/A,QXC9,QXC9/A,QXE,QXE/A,QXEB,QXE2,QXE4,QXE4/A,QXE6,QXE6/A QXE8,QXE8/A,QXQ4,QXQ4/A,QXU,QXU/A,QX2,SE,SE/A,SH,SH/A,SHB3,SHB3/A SHE,SHEZ,SHQ4,SHQ4/A,SJ/A,SJG/A,SKE/A,SKZ/A,SME0,SME0/A,SME2,SMX2 SMX2/A,STP,STP/A,STQ,STQ/A,SX,SX/A,SXB,SXB/A,SXB7,SXB7/A,SXE SXE/A,SXEB,SXEB/A,SXE2,SXE4,SXE4/A,SXE8,SXE8/A,SXP,SXQ4,SXQ4/A SXU,SXU/A,VA,VAA,VAAE,VAD2,VAD2/A,VAH1,VAH2,VAW1,VA2,VA2/A,VDE VDE2,VDE2/A,VD16,VE,VEB6,VH,VHE,VH12,VH12/A,VH22,VH22/A,VMX,VNG VNG1,VNG2,VSH7,VWA,VWA2,VWC2,VWC2/A,VWE2,VWE2/A,VWS2,VWS2/A,VW12 VW12/A,VX,VX/A,VXA,VXB,VXB/A,VXB2,VXB7,VXB7/A,VXE,VXE/A,VXEB VXEB/A,VXE2,VXE2/A,VXE4,VXE6,VXE7,VXE7/A,VXE8,VXE8/A,VXG,VXK,VXQ4 VXQ4/A,VXU,VXU/A,VXU1,VXU1/A,VX16,VX16/A,VX8,VX8/A,ZK1,ZK1/A  1 - - - 3032024 ----- EDN5,LJ,LJG,QHB3,SDE,SJ,SJG,SKE,SKZ 1 - - - ----- 2427098 LHB1,SHB1 1 - - - ----- 2593055 ES1 - (1) 1



Ref. No.	Part No.	Description	Reqd. QTY			Serial No.	Parts catalogue code	
			(1)	(2)	(3)			
19)	98079-56854	PLUG, SPARK (W20EP-U) (DENSO)	1	-	-	-----	BJ,EN,ES,ES1/A,ET,ETS,ETX,LP,LSX,LT,LT/A,LWD,QT,QT/A,STJ,STJ/A,YJ	
			1	-	-	2427099	-----	LHB1,SHB1
			1	-	-	2593056	-----	ES1
			1	-	-	3032023	-----	EDN5,LJ,LJG,QHB3,SDE,SJ,SJG,SKE,SKZ
			-	(1)	-	-----	-----	
	98079-56855	PLUG, SPARK (W20EPR-U) (DENSO)	1	-	-	-----	EDK,EDN5/A,ED7,ED8,ED8/A,ED9,ED9/A,ES2,HA,HAQ,HA2,HA2/A,HH,HX,HX2	
								HX26,HX26/A,LH,LH/A,LHB3,LHB3/A,LHB5,LHC,LHE,LHE/A,LHQ4,LHQ4/A
								LHW,LJ/A,LJG/A,LJS,LJS/A,LJS1,LKE,LKE/A,LX,LX/A,LXE,LXE/A,LXE2
								LX2/A,LX26,LX26/A,PKT2,PKT2/A,PKT4,PKT4/A,PKX2,PKX4,PKX4/A,PX
								PX/A,PXA2,PXE8,PXE8/A,QA,QAB2,QAB2/A,QAC2,QAC2/A,QAQ,QAQ2,QAQ2/A
					QA2/A,QA26,QA26/A,QDW9,QDW9/A,QE,QE/A,QH,QH/A,QHB3/A,QHB5,QHC,QHE			
					QHE/A,QHP1,QHP1/A,QHQ4,QHQ4/A,QH2,QKA4,QKA4/A,QL2,QME8,QME8/A,QMH			
					QMH/A,QMT2,QMT2/A,QMX2,QNE,QNE2,QNE2/A,QNE6,QNE9,QNE9/A,QNR2			
					QNR2/A,QNR6,QNR6/A,QN18,QP,QP/A,QPE2,QTC2,QTC2/A,QWH2,QWH2/A,QX			
					QX/A,QXB,QXB/A,QXB7,QXB7/A,QXC,QXC/A,QXC4,QXC4/A,QXC6,QXC6/A,QXC9			
					QXC9/A,QXE,QXE/A,QXEB,QXE2,QXE4,QXE4/A,QXE6,QXE6/A,QXE8,QXE8/A			
					QXQ4,QXQ4/A,QXU,QXU/A,QX2,SE,SE/A,SH,SH/A,SHB3,SHB3/A,SHE,SHEZ			
					SHQ4,SHQ4/A,SJ/A,SJG/A,SKE/A,SKZ/A,SME2,SMX2,SMX2/A,STP,STP/A,STQ			
					STQ/A,SWX,SWX/A,SX,SX/A,SXB,SXB/A,SXB7,SXB7/A,SXE,SXE/A,SXEB			
					SXEB/A,SXE2,SXE4,SXE4/A,SXE8,SXE8/A,SXP,SXQ4,SXQ4/A,SXU,SXU/A,VA			
					VAA,VAE,VAD2,VAD2/A,VAH1,VAH2,VAW1,VA2,VA2/A,VDE,VDE2,VDE2/A			
					VD16,VE,VEB6,VH,VHE,VH12,VH12/A,VH22,VH22/A,VMX,VNG,VNG1,VNG2			
					VSH7,VWA,VWA2,VWC2,VWC2/A,VWE2,VWE2/A,VWS2,VWS2/A,VW12,VW12/A,VX			
					VX/A,VXA,VXB,VXB/A,VXB2,VXB7,VXB7/A,VXE,VXE/A,VXEB,VXEB/A,VXE2			
					VXE2/A,VXE4,VXE6,VXE7,VXE7/A,VXE8,VXE8/A,VXG,VXK,VXQ4,VXQ4/A,VXU			
					VXU/A,VXU1,VXU1/A,VX16,VX16/A,VX8,VX8/A,ZK1,ZK1/A			
					EDN5,LJ,LJG,QHB3,SDE,SJ,SJG,SKE,SKZ			
					2427098 LHB1,SHB1			
					2593055 ES1			
					QME0/A,SME0/A			
					3032024 QME0,SME0			
			(1)	-	-----			
			-	(1)	1			
20	15721-ZE3-L60 15721-ZE3-L61	TUBE, BREATHER .....	1	-	-	-----	2483825 ZK1	
			1	-	-	-----	ZK1/A	
			1	-	-	2483826	-----	ZK1
21	15772-292-010	CLIP, BREATHER TUBE .....	2	-	-	-----	ZK1,ZK1/A	
			2	-	-	-----	LWD1,LWD1/A	
22	15721-ZE3-H00	TUBE, BREATHER .....	1	-	-	-----		



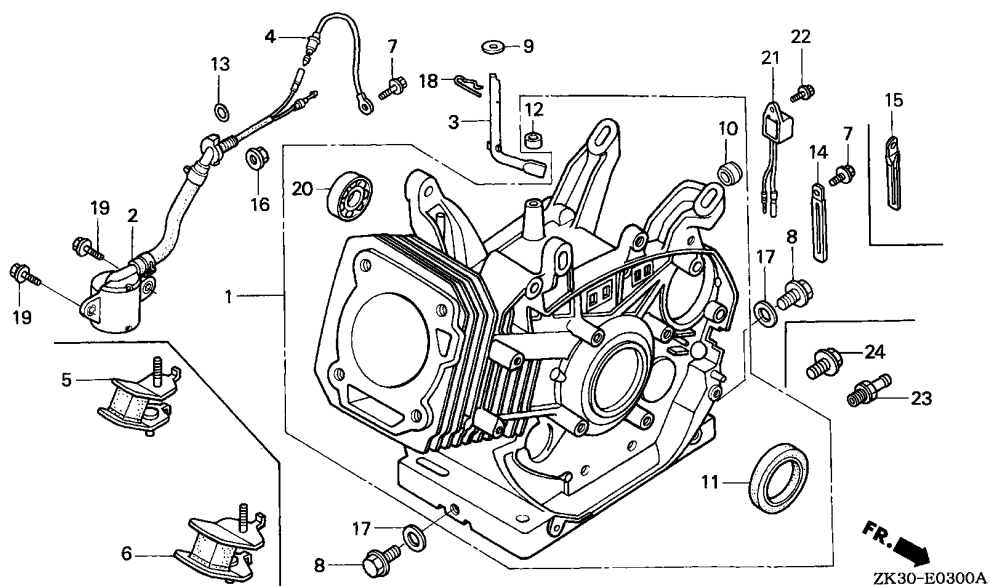

Ref. No.	L.O.N.	(Relative ref. Number) Description	F.R.T.
1	1101A0	BARREL, CYLINDER .....	1.8
2		(13)	
	6151E8	SWITCH, OIL LEVEL .....	0.5
	3	1161B4 SHAFT, GOVERNOR ARM .....	0.9
	4	6111E5 SUB HARNESS, OIL LEVEL SWITCH	0.1
	11	1101E4 OIL SEAL, CRANKSHAFT :FRONT ..	1.8
	12	1101C4 OIL SEAL, GOVERNOR ARM SHAFT ..	0.9
	17	1101D5 WASHER, DRAIN PLUG .....	0.1
	20	1101F4 BEARING, BALANCER WEIGHT :FRONT .....	1.9
	21	6151A0 ALERT UNIT, ENGINE OIL .....	0.1

2

Ref. No.	Part No.	Description	Reqd. QTY			Serial No.	Parts catalogue code
			GX	(1)	(2)		
1	120A0-ZE3-040	BARREL ASSY., CYLINDER (STD.)	1	(1)	-	2137033	BJ,EN,ES,ET,HH,LH,LHC,LJ,L1,P1,QE,QH,QHC,QP,QT,Q1,SE,SH,SJ,STP,STQ,S1,VE,VH,V1,YJ
	120A0-ZE3-050	.....	1	-	-	2251538	ED8
			1	-	-	2137034	2249245 BJ,LJ,SJ,STP,STQ,YJ
			1	-	-	2137034	2251538 ES,HH,LH,LHC,QE,QH,QHC,QP,QT,SE,SH,VE,VH
			1	-	-	2137034	2326583 EN,ET
	12000-ZE3-060	.....	1	(1)	-		L1,P1,Q1,S1,V1
			1	-	-		LHB1,LHW,QH2,VTE2
			1	-	-	2249246	BJ,YJ
			1	-	-	2251539	ES,HH,LHC,QHC,VE,VH
			1	-	-	2326584	EN,ET
			1	-	-	3105642	QKA4
			1	-	-	3334263	LHB3,LHQ4,LJG,LT,QHB3,QHP1,QHQ4,QMH,SHB1,SHB3,SHQ4,SJG,SKZ,STR
			1	-	-	2249246	3334263 LJ,SJ,STP,STQ
			1	-	-	2251539	3334263 ED8,LH,QE,QH,QP,QT,SE,SH
	12000-ZE3-070	.....	1	-	-		LJS
			1	-	-	3334264	SHB1
	12000-ZE3-080	.....	1	-	-	3334264	ED8,LH,LHB3,LHQ4,LJ,LJG,LT,QE,QH,QHB3,QHP1,QHQ4,QMH,QP,QT,SE,SH,SHB3,SHQ4,SJ,SJG,SKZ,STP,STQ,STR
	120A0-ZE3-W00	BARREL ASSY., CYLINDER .....	-	(1)	-	2249751	L1,P1,Q1,S1,V1
	12000-ZE3-W01	.....	1	-	-	2280087	LP
	120A0-ZE3-814	BARREL ASSY., CYLINDER (ALERT)	1	(1)	-	2280088	LP
			1	(1)	-	2166657	ED6,ES1,ES3,ETX,HA,HX,LX,LXZ,L1,PX,P1,QA,QAP,QX,QXB,QXC,Q1,SWX,SX,SBX,SXP,S1,VA,VAA,VNG,VNG1,VX,VXA,VXB,V1

Ref. No.	Part No.	Description	Reqd. QTY			Serial No.	Parts catalogue code
			(1)	(2)	(3)		
(1)	120A0-ZE3-815	BARREL ASSY., CYLINDER (ALERT)	1	-	-	2248168	EDN,ED9
			1	-	-	2252129	VAH1
			1	-	-	2262918	HAQ,QAQ
			1	-	-	2166658	ED6,ES1,ES3,ETX,HX,LXZ,PX,QX,QXB,SWX,SX, SXB,VAA,VNG,VNG1,VX,VXB
			1	-	-	2166658	2252129 HA,LX,QA,QAP,QXC,SXP,VA,VXA
			-	(1)	-	2166658	2249750 L1,P1,Q1,S1,V1
	12000-ZE3-816	.....	1	(1)	-	-----	EDT2,HX2,LSX,L1/A,P1/A,QMX2,QX2,Q1/A,SHT,S1/A,VAW1,VDE,VD16,VMX VXB2,VXG
			1	-	-	2248169	----- EDN,ETX,HX,LXZ,VAA,VNG,VNG1
			1	-	-	2252130	----- HA,QA,QAP,SXP,VA,VAH1,VXA
			1	-	-	2262919	----- HAQ,QAQ
			1	-	-	3334263	EDN2,EDN5,EDT1,HA2,HX26,LXQ4,LXU,LX2,LX26,PKT2,PKT4,PKX4,QAB2 QAH2,QAP2,QA2,QA26,QDW9,QMT2,QT2,QXC4,QXC6,QXC9,QXQ4,QXU,SMX2 SXQ4,SXU,VAD2,VA2,VDE2,VH12,VWC2,VW12,VXQ4,VXU,VX16,VX8
			1	-	-	2248169	3334263 ED6,ED9,ES1,ES3,PX,QX,QXB,SWX,SX,SXB,VX,VXB
			1	-	-	2252130	3334263 LX,QXC
			1	-	-	3105643	3334263 QKA4
			-	(1)	-	2249751	----- L1,P1,Q1,S1,V1
	120A0-ZE3-824	BARREL ASSY., CYLINDER (SELFSTARTER+ALERT)	1	(1)	-	2137768	ETS,LKE,LXE,L1,P1,QAE,QAPE,QNE,QXE,QXEB,Q1,STJ,SXE,SXEB,S1,VAAE VNG2,VXE,VXEB,V1
	120A0-ZE3-825	.....	1	-	-	2250345	EDS,ES4,VAH2,VWA
			1	-	-	2288955	QNE9
			1	-	-	2137769	2250345 ETS,LKE,LXE,QAE,QAPE,QNE,QXE,QXEB,SXE,SXEB,VAAE,VNG2,VXE,VXEB
			1	-	-	2137769	2357309 STJ
			-	(1)	-	2137769	2249750 L1,P1,Q1,S1,V1
	12000-ZE3-415	BARREL ASSY., CYLINDER (STD.)	1	1	-	-----	ED8/A,LH/A,LHB3/A,LHB5,LHQ4/A,LJ/A,LJG/A,LJS/A,LJS1,LT/A,L1/A P1/A,QE/A,QH/A,QHB3/A,QHB5,QHP1/A,QHQ4/A,QMH/A,QP/A,QT/A,Q1/A SE/A,SH/A,SHB3/A,SHQ4/A,SJ/A,SJG/A,SKZ/A,STP/A,STQ/A,STR/A,S1/A EDK,EDN2/A,EDN5/A,EDT1/A,EDT3,EDT6/A,ED6/A,ED9/A,EMT,EMT/A,EN6/A ES1/A,ES2,ES3/A,HA2/A,HX26/A,LX/A,LXQ4/A,LXU/A,LX2/A,LX26/A PKT2/A,PKT4/A,PKX2,PKX4/A,PX/A,PXA2,QAB2/A,QAC2/A,QAG/A,QAH2/A QAP2/A,QA2/A,QA26/A,QDW9/A,QKA4/A,QMT2/A,QT2/A,QWH2/A,QX/A,QXB/A QXB7/A,QXC/A,QXC4/A,QXC6/A,QXC9/A,QXQ4/A,QXU/A,SMX2/A,SWX/A,SX/A SXB/A,SXB7/A,SXQ4/A,SXU/A,VAD2/A,VA2/A,VC2/A,VDE2/A,VH12/A,VSH7 VS2,VS3,VS4,VWC,VWC2/A,VW12/A,VX/A,VXB/A,VXB7/A,VXK,VXQ4/A,VXU/A VX16/A,VX8/A
	12000-ZE3-416	BARREL ASSY., CYLINDER (ALERT)	1	-	-	-----	ED2/A,EDS1/A,EDS2/A,EDS4,EDS6/A,EDT/A,ENT/A,ENT2,ES4/A,LKE/A LXE/A,LXE2/A,LXE4/A,LXE8/A,PXE8/A,QAE2/A,QAE6/A,QMEO/A,QME8/A QNE2/A,QNE9/A,QNR2/A,QNR6/A,QXE/A,QXE4/A,QXE6/A,QXE8/A,SME0/A STJ/A,SXE/A,SXEB/A,SXE4/A,SXE8/A,VH22/A,VMQ,VMT/A,VS5,VS6,VS7,VWE VWE2/A,VWS2/A,VXE/A,VXEB/A,VXE2/A,VXE7/A,VXE8/A,VXU1/A
	12000-ZE3-417	BARREL ASSY., CYLINDER (SELFSTARTER+ALERT)	1	-	-	-----	LHE/A,LWD,LWD1/A,QHE/A,SKE/A,ZK1/A
	12000-ZE3-418	BARREL ASSY., CYLINDER (SELF-STARTER)	1	-	-	-----	EDT6,EMT,EN6,QAC2,QAG,QWH2,QXB7,SXB7,VC2,VXB7
	12000-ZE3-818	BARREL ASSY., CYLINDER (ALERT)	1	-	-	3334264	----- EDN2,EDN5,EDT1,ED6,ED9,ES1,ES3,HA2,HX26,LX,LXQ4,LXU,LX2,LX26,PKT2 PKT4,PKX4,PX,QAB2,QAH2,QAP2,QA2,QA26,QDW9,QKA4,QMT2,QT2,QX,QXB QXC,QXC4,QXC6,QXC9,QXQ4,QXU,SMX2,SWX,SX,SXB,SXQ4,SXU,VAD2,VA2 VDE2,VH12,VWC2,VW12,VX,VXB,VXQ4,VXU,VX16,VX8
			-	-	1		



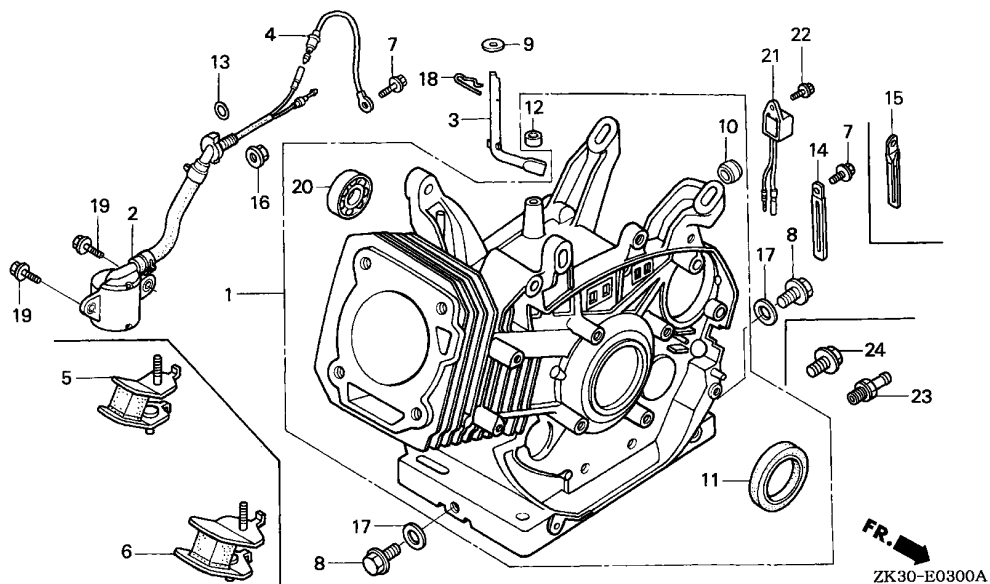

Ref. No.	Part No.	Description	Reqd. QTY			Serial No.	Parts catalogue code	
			GX	340K1	(3)			
(1)	12000-ZE3-826	BARREL ASSY., CYLINDER (SELFSTARTER+ALERT)	1	(1)	-	-----	EDS3,EDS5,LXE6,L1/A,P1/A,QNE6,QN18,QPE2,QXE2,Q1/A,SME2,SXE2,S1/A VEB6,VWA2,VXE4,VXE6	
			1	-	-	2250346	-----	EDS,ETS,QAE,QAPE,QNE,QXEB,VAAE,VAH2,VNG2,VWA
			1	-	-	3334263	3334263	EDE2,EDS1,EDS2,LXE2,LXE4,LXE8,PXE8,QAE2,QAE6,QL2,QMEO,QME8,QNE2 QNR2,QNR6,QXE4,QXE6,QXE8,SME0,SXE4,SXE8,VH22,VMT,VWE2,VWS2,VXE2 VXE8,VXU1
			1	-	-	2250346	3334263	ES4,LKE,LXE,QXE,SXE,SXEB,VXE,VXEB
			1	-	-	2288956	3334263	QNE9
			1	-	-	2357310	3334263	STJ
			-	(1)	-	2249751	-----	L1,P1,Q1,S1,V1
	120A0-ZE3-834	BARREL ASSY., CYLINDER (SELF-STARTER)	1	(1)	-	2135804	2135804	ED7,LHE,L1,P1,QHE,Q1,SHE,SHEZ,S1,VHE,V1
	120A0-ZE3-835	.....	1	-	-	2135805	2251594	ED7,LHE,QHE,SHE,SHEZ,VHE
			-	(1)	-	2135805	2249750	L1,P1,Q1,S1,V1
	12000-ZE3-828	BARREL ASSY., CYLINDER (SELFSTARTER+ALERT)	1	-	-	-----	-----	EDS6,EDT,ENT,VXE7
			1	-	-	3334264	3334264	EDE2,EDS1,EDS2,ES4,LKE,LXE,LXE2,LXE4,LXE8,PXE8,QAE2,QAE6,QL2,QMEO QME8,QNE2,QNE9,QNR2,QNR6,QXE,QXE4,QXE6,QXE8,SME0,STJ,SXE,SXEB SXE4,SXE8,VH22,VMT,VWE2,VWS2,VXE,VXEB,VXE2,VXE8,VXU1
	12000-ZE3-836	BARREL ASSY., CYLINDER (SELF-STARTER)	1	(1)	-	-----	-----	L1/A,P1/A,Q1/A,SDE,S1/A
			1	-	-	2251595	-----	ED7,SHE,SHEZ,VHE
			1	-	-	3334263	3334263	SKE,ZK1
			1	-	-	2251595	3334263	LHE,QHE
			-	(1)	-	2249751	-----	L1,P1,Q1,S1,V1
	12000-ZE3-838	.....	1	-	-	-----	-----	LWD1
			1	-	-	3334264	-----	LHE,QHE,SKE,ZK1

Ref. No.	Part No.	Description	Reqd. QTY			Serial No.	Parts catalogue code	
			(1)	(2)	(3)			
2	15510-ZE2-043	SWITCH ASSY., OIL LEVEL .....	1	(1)	-	-----	EDE2,EDE2/A,EDN,EDN2,EDN2/A,EDN5,EDN5/A,EDS,EDS1,EDS2,EDS2/A,EDS3,EDS5,EDS6,EDS6/A,EDT,EDT/A,EDT1,EDT2,EDT6,EDT6/A,ED6,ED6/A,ED9,EMT,ENT,ENT/A,ENT2,EN6,EN6/A,ES1,ES3,ES4,ETS,ETX,HA,HAQ,HA2,HA2/A,HX,HX2,HX26,HX26/A,LKE,LKE/A,LSX,LX,LXE,LXE2,LXE2/A,LXE4,LXE4/A,LXE6,LXE8,LXE8/A,LXQ4,LXQ4/A,LXU,LXU/A,LXZ,LX2,LX2/A,LX26,LX26/A,L1,PKT2,PKT2/A,PKT4,PKT4/A,PKX2,PKX4,PKX4/A,PX,PXA2,PXE8,PXE8/A,P1,P1/A,QA,QAB2,QAB2/A,QAC2,QAC2/A,QAE,QAE2,QAE2/A,QAE6,QAE6/A,QAG,QAG/A,QA2,QA2/A,QAH2,QA2/A,QAP,QAPE,QAP2,QAP2/A,QAQ,QA2,QA2/A,QA26,QA26/A,QDW9,QDW9/A,QKA4/A,QL2,QMEO,QMEO/A,QME8,QME8/A,QMT2,QMT2/A,QMX2,QNE,QNE2,QNE2/A,QNE6,QNE9,QNE9/A,QNR2,QNR2/A,QNR6,QNR6/A,QN18,QPE2,QTC2,QTC2/A,QWH2,QWH2/A,QX,QXB,QXB/A,QXB7,QXB7/A,QXC,QXC/A,QXC4,QXC4/A,QXC6,QXC6/A,QXC9,QXC9/A,QXE,QXEB,QXE2,QXE4,QXE4/A,QXE6,QXE6/A,QXE8,QXE8/A,QXQ4,QXQ4/A,QXU,QXU/A,QX2,Q1,Q1/A,SHT,SME0,SME0/A,SME2,SMX2,SMX2/A,STJ,SWX,SWX/A,SX,SXB,SXB/A,SXB7,SXB7/A,SXE,SXEB,SXEB/A,SXE2,SXE4,SXE4/A,SXE8,SXE8/A,SXP,SXQ4,SXQ4/A,SXU,SXU/A,S1,VA,VAA,VAAE,VAD2,VAD2/A,VAH1,VAH2,VAW1,VA2,VA2/A,VC2,VC2/A,VDE,VDE2,VDE2/A,VD16,VEB6,VH12,VH12/A,VH22,VH22/A,VMT,VMX,VNG,VNG1,VNG2,VSH7,VWA,VWA2,VWC,VWC2,VWC2/A,VWE,VWE2,VWE2/A,VWS2,VWS2/A,VW12,VW12/A,VX,VXA,VXB,VXB/A,VXB2,VXB7,VXB7/A,VXE,VXEB,VXEB/A,VXE2,VXE2/A,VXE4,VXE6,VXE7,VXE7/A,VXE8,VXE8/A,VXG,VXQ4,VXQ4/A,VXU,VXU1,VXU1/A,VX16,VX16/A,VX8,VX8/A,V1	
			1	(1)	-	-----	4074478	EDK,EDS1/A,EDS4,EDT1/A,ED9/A,EMT/A,ES1/A,ES3/A,ES4/A,LX/A,LXE/A,L1/A,PX/A,QX/A,QXE/A,STJ/A,SX/A,SXE/A,S1/A,VMQ,VMT/A,VS3,VS4,VS5,VS6,VX/A,VXE/A,VXK,VXU/A
			1	-	-	-----	3105643	QKA4
			-	-	1			
	15510-ZE2-053	.....	1	(1)	-	-----	4074479	EDK,EDS1/A,EDS4,EDT1/A,ED9/A,EMT/A,ES1/A,ES3/A,ES4/A,LX/A,LXE/A,L1/A,PX/A,QX/A,QXE/A,STJ/A,SX/A,SXE/A,S1/A,VMQ,VMT/A,VS3,VS4,VS5,VS6,VX/A,VXE/A,VXK,VXU/A
			1	-	-	-----	-----	EDT3,ES2,VS2,VS7



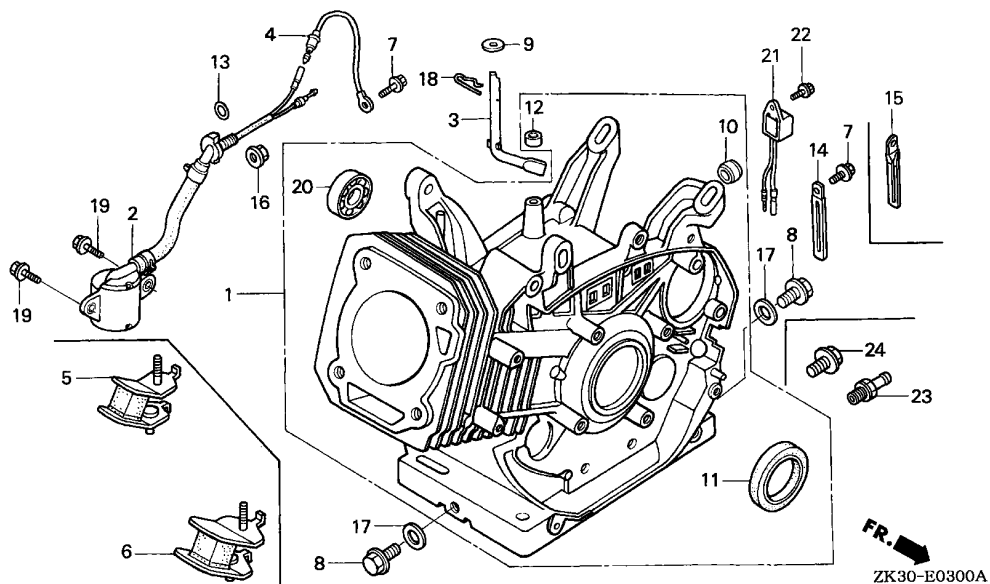

Ref. No.	Part No.	Description	Reqd. QTY			Serial No.	Parts catalogue code
			GX	(1)	(2)		
3	16541-ZE3-010	SHAFT, GOVERNOR ARM .....	1	-	-	-	BJ, EDE2, EDE2/A, EDK, EDN, EDN2, EDN2/A, EDN5, EDN5/A, EDS, EDS1, EDS1/A, EDS2, EDS2/A, EDS3, EDS4, EDS5, EDS6, EDS6/A, EDT, EDT/A, EDT1, EDT1/A, EDT2, EDT3, EDT6, EDT6/A, ED6, ED6/A, ED7, ED8, ED8/A, ED9, ED9/A, EMT, EMT/A, EN, ENT, ENT/A, ENT2, EN6, EN6/A, ES, ES1, ES1/A, ES2, ES3, ES3/A, ES4, ES4/A, ET, ETS, ETX, HA, HAQ, HA2, HA2/A, HH, HX, HX2, HX26, HX26/A, LH, LH/A, LHB3, LHB3/A, LHB5, LHC, LHE, LHE/A, LHQ4, LHQ4/A, LHW, LJ, LJ/A, LJG, LJG/A, LJS, LJS/A, LJS1, LKE, LKE/A, LXS, LT, LT/A, LWD, LWD1, LWD1/A, LX, LX/A, LXE, LXE/A, LXE2, LXE2/A, LXE4, LXE4/A, LXE6, LXE8, LXE8/A, LXQ4, LXQ4/A, LXU, LXU/A, LXZ, LXZ, LXZ2, LXZ2/A, LX26, LX26/A, PKT2, PKT2/A, PKT4, PKT4/A, PKX2, PKX4, PKX4/A, PX, PX/A, PXA2, PXE8, PXE8/A, QA, QAB2, QAB2/A, QAC2, QAC2/A, QAE, QAE2, QAE2/A, QAE6, QAE6/A, QAG, QAG/A, QAH2, QAH2/A, QAP, QAPE, QAP2, QAP2/A, QAQ, QA2, QA2/A, QA26, QA26/A, QDW9, QDW9/A, QE, QE/A, QH, QH/A, QHB3, QHB3/A, QHB5, QHC, QHE, QHE/A, QHP1, QHP1/A, QHQ4, QHQ4/A, QH2, QKA4, QKA4/A, QL2, QME0, QME0/A, QME8, QME8/A, QMH, QMH/A, QMT2, QMT2/A, QMX2, QNE, QNE2, QNE2/A, QNE6, QNE9, QNE9/A, QNR2, QNR2/A, QNR6, QNR6/A, QN18, QP, QP/A, QPE2, QT, QT/A, QTC2, QTC2/A, QWH2, QWH2/A, QX, QX/A, QXB, QXB/A, QXB7, QXB7/A, QXC, QXC/A, QXC4, QXC4/A, QXC6, QXC6/A, QXC9, QXC9/A, QXE, QXE/A, QXEB, QXE2, QXE4, QXE4/A, QXE6, QXE6/A, QXE8, QXE8/A, QXQ4, QXQ4/A, QXU, QXU/A, QX2, SDE, SE, SE/A, SH, SH/A, SHB1, SHB3, SHB3/A, SHE, SHEZ, SHQ4, SHQ4/A, SHT, SJ, SJ/A, SJG, SJG/A, SKE, SKE/A, SKZ, SKZ/A, SME0, SME0/A, SME2, SMX2, SMX2/A, STJ, STJ/A, STP, STP/A, STQ, STQ/A, STR, STR/A, SWX, SWX/A, SX, SX/A, SXB, SXB/A, SXB7, SXB7/A, SXE, SXE/A, SXEB, SXEB/A, SXE2, SXE4, SXE4/A, SXE8, SXE8/A, SXP, SXQ4, SXQ4/A, SXU, SXU/A, VA, VAA, VAAE, VAD2, VAD2/A, VAH1, VAH2, VAW1, VAZ, VAZ/A, VC2, VC2/A, VDE, VDE2, VDE2/A, VD16, VE, VEB6, VH, VHE, VH12, VH12/A, VH22, VH22/A, VMQ, VMT, VMT/A, VMX, VNG, VNG1, VNG2, VSH7, VS2, VS3, VS4, VS5, VS6, VS7, VTE2, VWA, VWA2, VWC, VWC2, VWC2/A, VWE, VWE2, VWE2/A, VWS2, VWS2/A, VW12, VW12/A, VX, VX/A, VXA, VXB, VXB/A, VXB2, VXB7, VXB7/A, VXE, VXE/A, VXE6, VXE6/A, VXE2, VXE2/A, VXE4, VXE6, VXE7, VXE7/A, VXE8, VXE8/A, VXG, VXK, VXQ4, VXQ4/A, VXU, VXU/A, VXU1, VXU1/A, VX16, VX16/A, VX8, VX8/A, YJ, ZK1, ZK1/A



Ref. No.	Part No.	Description	Reqd. QTY			Serial No.	Parts catalogue code
			(1)	(2)	(3)		
4	32197-ZE2-003	SUB HARNESS .....	1	-	-	-----	EDS,EDS1,EDS1/A,EDS3,EDS5,EDT1,EDT1/A,ED6,ED6/A,ED9,ED9/A,ES1 ES1/A,ETX,HA,HAQ,HA2,HA2/A,HX,HX2,HX26,HX26/A,LKE,LKE/A,LSX,LX LX/A,LXE,LXE/A,LXE2,LXE2/A,LXE4,LXE4/A,LXE6,LXQ4,LXQ4/A,LXZ,LX2 LX2/A,LX26,LX26/A,PKT2,PKT2/A,PX,PX/A,QA,QAQ,QAQ2,QAQ2/A,QAQ6 QAQ6/A,QAP,QAPE,QAP2,QAP2/A,QAQ,QA2,QA2/A,QA26,QA26/A,QDW9,QDW9/A QMEO,QMEO/A,QMT2,QMT2/A,QNE,QNE2,QNE2/A,QNE6,QNE9,QNE9/A,QNR2 QNR2/A,QNR6,QNR6/A,QN18,QPE2,QTC2,QTC2/A,QX,QX/A,QXB,QXB/A,QXC QXC/A,QXC4,QXC4/A,QXC6,QXC6/A,QXC9,QXC9/A,QXE,QXE/A,QXEB,QXE2 QXE4,QXE4/A,QXE6,QXE6/A,QXQ4,QXQ4/A,QX2,SHT,SMEO,SMEO/A,SME2,SMX2 SMX2/A,SWX,SWX/A,SX,SX/A,SXB,SXB/A,SXE,SXE/A,SXEB,SXEB/A,SXE2 SXE4,SXE4/A,SXP,SXQ4,SXQ4/A,VA,VAA,VAAE,VAD2,VAD2/A,VAH1,VAH2 VAW1,VA2,VA2/A,VDE,VDE2,VDE2/A,VD16,VEB6,VH12,VH12/A,VH22,VH22/A VNG,VNG1,VNG2,VWA,VWA2,VWC2,VWC2/A,VWE2,VWE2/A,VWS2,VWS2/A,VW12 VW12/A,VX,VX/A,VXA,VXB,VXB/A,VXB2,VXE,VXE/A,VXEB,VXEB/A,VXE2 VXE2/A,VXE4,VXE6,VXG,VXQ4,VXQ4/A,VXU,VXU/A,VXU1,VXU1/A,VX16 VX16/A
	31161-ZE2-000	CORD, EARTH .....	1	-	-	-----	EDE2,EDE2/A,EDN,EDN2,EDN2/A,ES3,ES3/A,ES4,ES4/A,ETS,STJ,STJ/A,VS2 VS3,VS4,VS5,VS6,VS7
5	68325-ZC2-000	RUBBER, BOTTOM .....	2	-	-	-----	ES,ES1,ES1/A,ES2,ES3,ES3/A,ES4,ES4/A,VS2,VS3,VS4,VS5,VS6,VS7
6	68325-899-000	RUBBER, BOTTOM .....	2	-	-	-----	ES,ES1,ES1/A,ES2,ES3,ES3/A,ES4,ES4/A,VS2,VS3,VS4,VS5,VS6,VS7
7	90013-883-000	BOLT, FLANGE, 6X12(CT200) ...	4	-	-	-----	SHT
			1	-	-	-----	EDE2,EDE2/A,EDN,EDN2,EDN2/A,EDS,EDS1,EDS1/A,EDS3,EDS5,EDT1,EDT1/A ED6,ED6/A,ED9,ED9/A,ES1,ES1/A,ES3,ES3/A,ETS,ETX,HA,HAQ,HA2,HA2/A HX,HX2,HX26,HX26/A,LKE,LKE/A,LSX,LX,LX/A,LXE,LXE/A,LXE2,LXE2/A LXE4,LXE4/A,LXE6,LXQ4,LXQ4/A,LXZ,LX2,LX2/A,LX26,LX26/A,PKT2 PKT2/A,PX,PX/A,QA,QAQ,QAQ2,QAQ2/A,QAQ6,QAQ6/A,QAP,QAPE,QAP2 QAP2/A,QAQ,QA2,QA2/A,QA26,QA26/A,QDW9,QDW9/A,QMEO,QMEO/A,QMT2 QMT2/A,QNE,QNE2,QNE2/A,QNE6,QNE9,QNE9/A,QNR2,QNR2/A,QNR6,QNR6/A QN18,QPE2,QTC2,QTC2/A,QX,QX/A,QXB,QXB/A,QXC,QXC/A,QXC4,QXC4/A QXC6,QXC6/A,QXC9,QXC9/A,QXE,QXE/A,QXEB,QXE2,QXE4,QXE4/A,QXE6 QXE6/A,QXQ4,QXQ4/A,QX2,SHT,SMEO,SMEO/A,SME2,SMX2,SMX2/A,STJ,STJ/A SWX,SWX/A,SX,SX/A,SXB,SXB/A,SXE,SXE/A,SXEB,SXEB/A,SXE2,SXE4 SXE4/A,SXP,SXQ4,SXQ4/A,VA,VAA,VAAE,VAD2,VAD2/A,VAH1,VAH2,VAW1,VA2 VA2/A,VDE,VDE2,VDE2/A,VD16,VEB6,VH12,VH12/A,VH22,VH22/A,VNG,VNG1 VNG2,VS3,VS6,VS7,VWA,VWA2,VWC2,VWC2/A,VWE2,VWE2/A,VWS2,VWS2/A VW12,VW12/A,VX,VX/A,VXA,VXB,VXB/A,VXB2,VXE,VXE/A,VXEB,VXEB/A,VXE2 VXE2/A,VXE4,VXE6,VXG,VXQ4,VXQ4/A,VXU,VXU/A,VXU1,VXU1/A,VX16 VX16/A
			2	-	-	-----	VS5
			3	-	-	-----	ES4,ES4/A
			-	(1)	1	-----	
8	90131-883-000	BOLT, DRAIN PLUG, 12X15 .....	2	2	2		



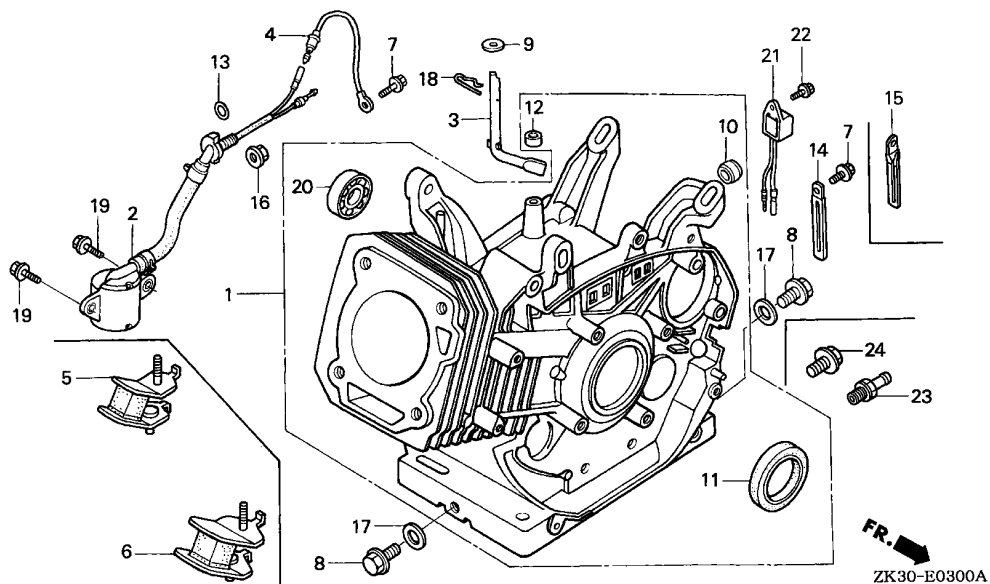

2

Ref. No.	Part No.	Description	Reqd. QTY			Serial No.	Parts catalogue code
			GX	(1)	(2)		
9	90446-KE1-000	WASHER, 8.2X17X0.8	1	-	-	-	BJ, EDE2, EDE2/A, EDK, EDN, EDN2, EDN2/A, EDN5, EDN5/A, EDS, EDS1, EDS1/A, EDS2, EDS2/A, EDS3, EDS4, EDS5, EDS6, EDS6/A, EDT, EDT/A, EDT1, EDT1/A, EDT2, EDT3, EDT6, EDT6/A, ED6, ED6/A, ED7, ED8, ED8/A, ED9, ED9/A, EMT, EMT/A, EN, ENT, ENT/A, ENT2, EN6, EN6/A, ES, ES1, ES1/A, ES2, ES3, ES3/A, ES4, ES4/A, ET, ETS, ETX, HA, HAQ, HA2, HA2/A, HH, HX, HX2, HX26, HX26/A, LH, LH/A, LHB3, LHB3/A, LHB5, LHC, LHE, LHE/A, LHQ4, LHQ4/A, LHW, LJ, LJ/A, LJG, LJG/A, LJS, LJS/A, LJS1, LKE, LKE/A, LXS, LT, LT/A, LWD, LWD1, LWD1/A, LX, LX/A, LXE, LXE/A, LXE2, LXE2/A, LXE4, LXE4/A, LXE6, LXE8, LXE8/A, LXQ4, LXQ4/A, LXU, LXU/A, LXZ, LXZ, LX2, LX2/A, LX26, LX26/A, PKT2, PKT2/A, PKT4, PKT4/A, PKX2, PKX4, PKX4/A, PX, PX/A, PXA2, PXE8, PXE8/A, QA, QAB2, QAB2/A, QAC2, QAC2/A, QAE, QAE2, QAE2/A, QAE6, QAE6/A, QAG, QAG/A, QAH2, QAH2/A, QAP, QAPE, QAP2, QAP2/A, QAQ, QA2, QA2/A, QA26, QA26/A, QDW9, QDW9/A, QE, QE/A, QH, QH/A, QHB3, QHB3/A, QHB5, QHC, QHE, QHE/A, QHP1, QHP1/A, QHQ4, QHQ4/A, QH2, QKA4, QKA4/A, QL2, QME0, QME0/A, QME8, QME8/A, QMH, QMH/A, QMT2, QMT2/A, QMX2, QNE, QNE2, QNE2/A, QNE6, QNE9, QNE9/A, QNR2, QNR2/A, QNR6, QNR6/A, QN18, QP, QP/A, QPE2, QT, QT/A, QTC2, QTC2/A, QWH2, QWH2/A, QX, QX/A, QXB, QXB/A, QXB7, QXB7/A, QXC, QXC/A, QXC4, QXC4/A, QXC6, QXC6/A, QXC9, QXC9/A, QXE, QXE/A, QXEB, QXE2, QXE4, QXE4/A, QXE6, QXE6/A, QXE8, QXE8/A, QXQ4, QXQ4/A, QXU, QXU/A, QX2, SDE, SE, SE/A, SH, SH/A, SHB1, SHB3, SHB3/A, SHE, SHEZ, SHQ4, SHQ4/A, SHT, SJ, SJ/A, SJG, SJG/A, SKE, SKE/A, SKZ, SKZ/A, SME0, SME0/A, SME2, SMX2, SMX2/A, STJ, STJ/A, STP, STP/A, STQ, STQ/A, STR, STR/A, SWX, SWX/A, SX, SX/A, SXB, SXB/A, SXB7, SXB7/A, SXE, SXE/A, SXEB, SXEB/A, SXE2, SXE4, SXE4/A, SXE8, SXE8/A, SXP, SXQ4, SXQ4/A, SXU, SXU/A, VA, VAA, VAAE, VAD2, VAD2/A, VAH1, VAH2, VAW1, VA2, VA2/A, VC2, VC2/A, VDE, VDE2, VDE2/A, VD16, VE, VEB6, VH, VHE, VH12, VH12/A, VH22, VH22/A, VMQ, VMT, VMT/A, VMX, VNG, VNG1, VNG2, VSH7, VS2, VS3, VS4, VS5, VS6, VS7, VTE2, VMA, VMA2, VWC, VWC2, VWC2/A, VWE, VWE2, VWE2/A, VWS2, VWS2/A, VW12, VW12/A, VX, VX/A, VXA, VXB, VXB/A, VXB2, VXB7, VXB7/A, VXE, VXE/A, VXEB, VXEB/A, VXE2, VXE2/A, VXE4, VXE6, VXE7, VXE7/A, VXE8, VXE8/A, VXG, VXK, VXQ4, VXQ4/A, VXU, VXU/A, VXU1, VXU1/A, VX16, VX16/A, VX8, VX8/A, YJ, ZK1, ZK1/A



Ref. No.	Part No.	Description	Reqd. QTY			Serial No.	Parts catalogue code
			(1)	(2)	(3)		
10	90801-ZE2-003	PLUG, SEALING (RUBBER 10MM)	1	(1)	-	-----	BJ, EDE2, EDN2, EDN5, EDS1, EDS2, EDS6, EDT, EDT1, EDT2, EDT6, ED6, ED8, ED9, EMT, ENT, EN6, ES1, ES3, ES4, HAQ, HA2, HX2, HX26, LH, LHB3, LHE, LHQ4, LJ, LJG, LJS, LKE, LSX, LT, LWD1, LX, LXE, LXE2, LXE4, LXE8, LXQ4, LXU, LX2, LX26, L1, PKT2, PKT4, PKX4, PX, PXE8, P1, QAB2, QAC2, QAE2, QAE6, QAG, QAH2, QAP2, QAA, QA2, QA26, QDW9, QE, QH, QHB3, QHE, QHP1, QHQ4, QH2, QL2, QMEO, QME8, QMH, QMT2, QMX2, QNE2, QNE9, QNR2, QNR6, QN18, QP, QPE2, QT, QTC2, QWH2, QX, QXB, QXC, QXC4, QXC6, QXC9, QXE, QXE2, QXE4, QXE6, QXE8, QXQ4, QXU, QX2, Q1, SDE, SE, SH, SHB1, SHB3, SHQ4, SJ, SJG, SKE, SKZ, SMEO, SME2, SMX2, STJ, STP, STQ, STR, SWX, SX, SXB7, SXE, SXEB, SXE2, SXE4, SXE8, SXQ4, SXU, S1, VAD2, VAW1, VA2, VC2, VDE, VDE2, VH12, VH22, VMT, VWA, VWA2, VWC2, VWE2, VWS2, VW12, VX, VXB, VXE, VXE2, VXE8, VXQ4, VXU, VXU1, VX16, VX8, V1, YJ, ZK1
			1	(1)	-	-----	3989445 EDE2/A, EDN2/A, EDN5/A, EDS1/A, EDS2/A, EDS6/A, EDT/A, EDT1/A, EDT6/A, ED6/A, ED8/A, ED9/A, EMT/A, ENT/A, ENT2, EN6/A, ES1/A, ES3/A, ES4/A, HA2/A, HX26/A, LH/A, LHB3/A, LHB5, LHE/A, LHQ4/A, LJ/A, LJG/A, LJS/A, LJS1, LKE/A, LT/A, LWD, LWD1/A, LX/A, LXE/A, LXE2/A, LXE4/A, LXE8/A, LXQ4/A, LXU/A, LX2/A, LX26/A, L1/A, PKT2/A, PKT4/A, PKX2, PKX4/A, PX/A, PXE8/A, P1/A, QAB2/A, QAC2/A, QAE2/A, QAE6/A, QAG/A, QAH2/A, QAP2/A, QA2/A, QA26/A, QDW9/A, QE/A, QH/A, QHB3/A, QHB5, QHE/A, QHP1/A, QHQ4/A, QKA4/A, QMEO/A, QME8/A, QMH/A, QMT2/A, QNE2/A, QNE9/A, QNR2/A, QNR6/A, QP/A, QT/A, QTC2/A, QWH2/A, QX/A, QXB/A, QXC/A, QXC4/A, QXC6/A, QXC9/A, QXE/A, QXE4/A, QXE6/A, QXE8/A, QXQ4/A, QXU/A, Q1/A, SE/A, SH/A, SHB3/A, SHQ4/A, SJ/A, SJG/A, SKE/A, SKZ/A, SMEO/A, SMX2/A, STJ/A, STP/A, STQ/A, STR/A, SWX/A, SX/A, SXB7/A, SXE/A, SXEB/A, SXE4/A, SXE8/A, SXQ4/A, SXU/A, S1/A, VAD2/A, VA2/A, VC2/A, VDE2/A, VH12/A, VH22/A, VMT/A, VWC2/A, VWE2/A, VWS2/A, VW12/A, VX/A, VXB/A, VXE/A, VXE2/A, VXE8/A, VXQ4/A, VXU/A, VXU1/A, VX16/A, VX8/A, ZK1/A
			1	-	-	-----	3105642 QKA4
11	91201-ZE3-004	OIL SEAL, 35X52X8 .....	1	(1)	1		



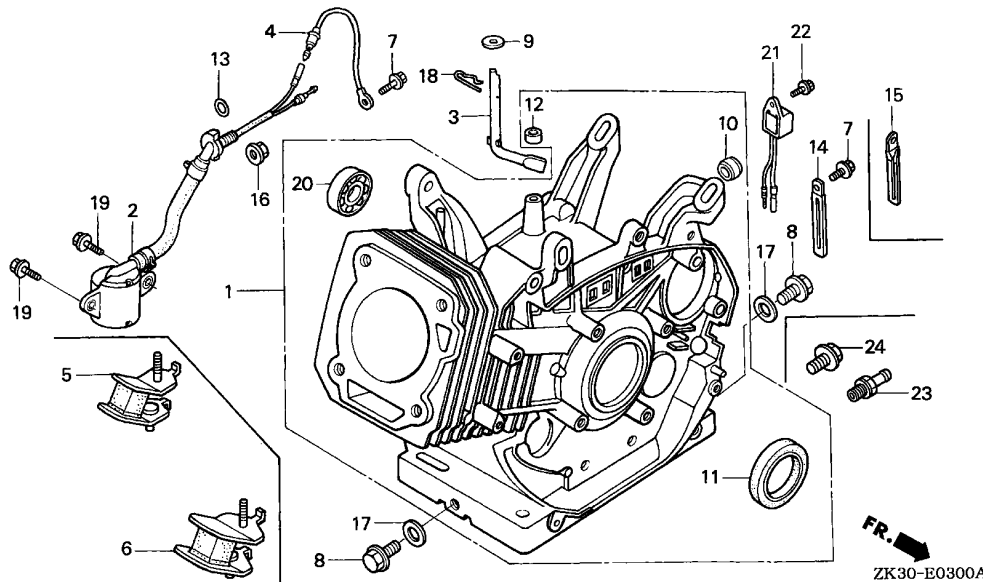

Ref. No.	Part No.	Description	Reqd. QTY GX 340K1 (1) (2) (3)	Serial No.	Parts catalogue code
12	91203-952-771	OIL SEAL, 8X14X5 .....	1 - -		BJ, EDE2, EDE2/A, EDK, EDN, EDN2, EDN2/A, EDN5, EDN5/A, EDS, EDS1, EDS1/A, EDS2, EDS2/A, EDS3, EDS4, EDS5, EDS5, EDS6, EDS6/A, EDT, EDT/A, EDT1, EDT1/A, EDT2, EDT3, EDT6, EDT6/A, ED6, ED6/A, ED7, ED8, ED8/A, ED9, ED9/A, EMT, EMT/A, EN, ENT, ENT/A, ENT2, EN6, EN6/A, ES, ES1, ES1/A, ES2, ES3, ES3/A, ES4, ES4/A, ET, ETS, ETX, HA, HAQ, HA2, HA2/A, HH, HX, HX2, HX26, HX26/A, LH, LH/A, LHB1, LHB3, LHB3/A, LHB5, LHC, LHE, LHE/A, LHQ4, LHQ4/A, LHW, LJ, LJ/A, LJG, LJG/A, LJS, LJS/A, LJS1, LKE, LKE/A, LXS, LT, LT/A, LWD, LWD1, LWD1/A, LX, LX/A, LXE, LXE/A, LXE2, LXE2/A, LXE4, LXE4/A, LXE6, LXE8, LXE8/A, LXQ4, LXQ4/A, LXU, LXU/A, LXZ, LX2, LX2/A, LX26, LX26/A, PKT2, PKT2/A, PKT4, PKT4/A, PKX2, PKX4, PKX4/A, PX, PX/A, PXA2, PXE8, PXE8/A, QA, QAB2, QAB2/A, QAC2, QAC2/A, QAE, QAE2, QAE2/A, QAE6, QAE6/A, QAG, QAG/A, QAH2, QAH2/A, QAP, QAPE, QAP2, QAP2/A, QAQ, QA2, QA2/A, QA26, QA26/A, QDW9, QDW9/A, QE, QE/A, QH, QH/A, QHB3, QHB3/A, QHB5, QHC, QHE, QHE/A, QHP1, QHP1/A, QHQ4, QHQ4/A, QH2, QKA4, QKA4/A, QL2, QME0, QME0/A, QME8, QME8/A, QMH, QMH/A, QMT2, QMT2/A, QMX2, QNE, QNE2, QNE2/A, QNE6, QNE9, QNE9/A, QNR2, QNR2/A, QNR6, QNR6/A, QN18, QP, QP/A, QPE2, QT, QT/A, QTC2, QTC2/A, QWH2, QWH2/A, QX, QX/A, QXB, QXB/A, QXB7, QXB7/A, QXC, QXC/A, QXC4, QXC4/A, QXC6, QXC6/A, QXC9, QXC9/A, QXE, QXE/A, QXEB, QXE2, QXE4, QXE4/A, QXE6, QXE6/A, QXE8, QXE8/A, QXQ4, QXQ4/A, QXU, QXU/A, QX2, SDE, SE, SE/A, SH, SH/A, SHB1, SHB3, SHB3/A, SHE, SHEZ, SHQ4, SHQ4/A, SHT, SJ, SJ/A, SJG, SJG/A, SKE, SKE/A, SKZ, SKZ/A, SMEO, SMEO/A, SME2, SMX2, SMX2/A, STJ, STJ/A, STP, STP/A, STQ, STQ/A, STR, STR/A, SWX, SWX/A, SX, SX/A, SXB, SXB/A, SXB7, SXB7/A, SXE, SXE/A, SXEB, SXEB/A, SXE2, SXE4, SXE4/A, SXE8, SXE8/A, SXP, SXQ4, SXQ4/A, SXU, SXU/A, VA, VAA, VAAE, VAD2, VAD2/A, VAH1, VAH2, VAW1, VA2, VA2/A, VC2, VC2/A, VDE, VDE2, VDE2/A, VD16, VE, VEB6, VH, VHE, VH12, VH12/A, VH22, VH22/A, VMQ, VMT, VMT/A, VMX, VNG, VNG1, VNG2, VSH7, VS2, VS3, VS4, VS5, VS6, VS7, VTE2, VWA, VWA2, VWC, VWC2, VWC2/A, VWE, VWE2, VWE2/A, VWS2, VWS2/A, VW12, VW12/A, VX, VX/A, VXA, VXB, VXB/A, VXB2, VXB7, VXB7/A, VXE, VXE/A, VXEB, VXEB/A, VXE2, VXE2/A, VXE4, VXE6, VXE7, VXE7/A, VXE8, VXE8/A, VXG, VXK, VXQ4, VXQ4/A, VXU, VXU/A, VXU1, VXU1/A, VX16, VX16/A, VX8, VX8/A, YJ, ZK1, ZK1/A

Ref. No.	Part No.	Description	Reqd. QTY			Serial No.	Parts catalogue code
			(1)	(2)	(3)		
12)	91203-952-771	OIL SEAL, 8X14X5 .....	-	1	1		
13	91353-671-004	O-RING, 14MM(NOK) .....	1	-	-	-----	EDE2,EDE2/A,EDK,EDN,EDN2,EDN2/A,EDN5,EDN5/A,EDS,EDS1,EDS1/A,EDS2,EDS2/A,EDS3,EDS4,EDS5,EDS6,EDS6/A,EDT,EDT/A,EDT1,EDT1/A,EDT2,EDT3,EDT6,EDT6/A,ED6,ED6/A,ED9,ED9/A,EMT,EMT/A,ENT,ENT/A,ENT2,EN6,EN6/A,ES1,ES1/A,ES2,ES3,ES3/A,ES4,ES4/A,ETS,ETX,HA,HAQ,HA2,HA2/A,HX,HX2,HX26,HX26/A,LKE,LKE/A,LSX,LX,LX/A,LXE,LXE/A,LXE2,LXE2/A,LXE4,LXE4/A,LXE6,LXE8,LXE8/A,LXQ4,LXQ4/A,LXU,LXU/A,LXZ,LX2/LX2/A,LX26,LX26/A,PKT2,PKT2/A,PKT4,PKT4/A,PKX2,PKX4,PKX4/A,PK,PK/A,PKA2,PXE8,PXE8/A,QA,QAB2,QAB2/A,QAC2,QAC2/A,QAQ,QAQ2,QAQ2/A,QAQ,QA2,QA2/A,QA26,QA26/A,QDW9,QDW9/A,QKA4/A,QL2,QMEO,QMEO/A,QME8,QME8/A,QMT2,QMT2/A,QMX2,QNE,QNE2,QNE2/A,QNE6,QNE9,QNE9/A,QNR2,QNR2/A,QNR6,QNR6/A,QN18,QPE2,QTC2,QTC2/A,QWH2,QWH2/A,QX,QX/A,QXB,QXB/A,QXB7,QXB7/A,QXC,QXC/A,QXC4,QXC4/A,QXC6,QXC6/A,QXC9,QXC9/A,QXE,QXE/A,QXEB,QXE2,QXE4,QXE4/A,QXE6,QXE6/A,QXE8,QXE8/A,QXQ4,QXQ4/A,QXU,QXU/A,QX2,SHT,SME0,SME0/A,SME2,SMX2,SMX2/A,STJ,STJ/A,SWX,SWX/A,SX,SX/A,SXB,SXB/A,SXB7,SXB7/A,SXE,SXE/A,SXEB,SXEB/A,SXE2,SXE4,SXE4/A,SXE8,SXE8/A,SXP,SXQ4,SXQ4/A,SXU,SXU/A,VA,VAA,VAE,VAD2,VAD2/A,VAH1,VAH2,VAW1,VA2,VA2/A,VC2,VC2/A,VDE,VDE2,VDE2/A,VD16,VEB6,VH12,VH12/A,VH22,VH22/A,VMQ,VMT,VMT/A,VMX,VNG,VNG1,VNG2,VSH7,VS2,VS3,VS4,VS5,VS6,VS7,VWA,VWA2,VWC,VWC2,VWC2/A,VVE,VVE2,VVE2/A,VWS2,VWS2/A,VW12,VW12/A,VX,VX/A,VXA,VXB,VXB/A,VXB2,VXB7,VXB7/A,VXE,VXE/A,VXEB,VXEB/A,VXE2,VXE2/A,VXE4,VXE6,VXE7,VXE7/A,VXE8,VXE8/A,VXG,VXK,VXQ4,VXQ4/A,VXU,VXU/A,VXU1,VXU1/A,VX16,VX16/A,VX8,VX8/A
			1	-	-	3105643	-----
			-	(1)	1		
14	91406-671-000	CLIP, WIRE HARNESS .....	1	-	-	-----	ES4
	91406-166-000	CLIP, WIRE .....	1	-	-	3757520	ES4/A
			1	-	-	3757521	VS5,VS6,VS7
			1	-	-	-----	ES4/A
15	91406-729-000	CLIP, HEAD .....	1	-	-	-----	ES4,ES4/A
16	94050-10000	NUT, FLANGE, 10MM .....	1	-	-	-----	EDE2,EDE2/A,EDK,EDN,EDN2,EDN2/A,EDN5,EDN5/A,EDS,EDS1,EDS1/A,EDS2,EDS2/A,EDS3,EDS4,EDS5,EDS6,EDS6/A,EDT,EDT/A,EDT1,EDT1/A,EDT2,EDT3,EDT6,EDT6/A,ED6,ED6/A,ED9,ED9/A,EMT,EMT/A,ENT,ENT/A,ENT2,EN6,EN6/A,ES1,ES1/A,ES2,ES3,ES3/A,ES4,ES4/A,ETS,ETX,HA,HAQ,HA2,HA2/A,HX,HX2,HX26,HX26/A,LKE,LKE/A,LSX,LX,LX/A,LXE,LXE/A,LXE2,LXE2/A,LXE4,LXE4/A,LXE6,LXE8,LXE8/A,LXQ4,LXQ4/A,LXU,LXU/A,LXZ,LX2,LX2/A,LX26,LX26/A,PKT2,PKT2/A,PKT4,PKT4/A,PKX2,PKX4,PKX4/A,PK,PK/A,PKA2,PXE8,PXE8/A,QA,QAB2,QAB2/A,QAC2,QAC2/A,QAQ,QAQ2,QAQ2/A,QAQ,QA2,QA2/A,QA26,QA26/A,QDW9,QDW9/A,QKA4/A,QL2,QMEO,QMEO/A,QME8,QME8/A,QMT2,QMT2/A,QMX2,QNE,QNE2,QNE2/A,QNE6,QNE9,QNE9/A,QNR2,QNR2/A,QNR6,QNR6/A,QN18,QPE2,QTC2,QTC2/A,QWH2,QWH2/A,QX,QX/A,QXB,QXB/A,QXB7,QXB7/A,QXC,QXC/A,QXC4,QXC4/A,QXC6,QXC6/A,QXC9,QXC9/A,QXE,QXE/A,QXEB,QXE2,QXE4,QXE4/A,QXE6,QXE6/A,QXE8,QXE8/A,QXQ4,QXQ4/A,QXU,QXU/A,QX2,SHT,SME0,SME0/A,SME2,SMX2,SMX2/A,STJ,STJ/A,SWX,SWX/A,SX,SX/A,SXB,SXB/A,SXB7,SXB7/A,SXE,SXE/A,SXEB,SXEB/A,SXE2,SXE4,SXE4/A,SXE8,SXE8/A,SXP,SXQ4,SXQ4/A,SXU,SXU/A,VA,VAA,VAE,VAD2,VAD2/A,VAH1,VAH2,VAW1,VA2,VA2/A,VC2,VC2/A,VDE,VDE2,VDE2/A,VD16,VEB6,VH12,VH12/A,VH22,VH22/A,VMQ,VMT,VMT/A,VMX,VNG,VNG1,VNG2,VSH7,VS2,VS3,VS4,VS5,VS6,VS7,VWA,VWA2,VWC,VWC2,VWC2/A,VVE,VVE2,VVE2/A,VWS2,VWS2/A,VW12,VW12/A,VX,VX/A,VXA,VXB,VXB/A,VXB2,VXB7,VXB7/A,VXE,VXE/A,VXEB,VXEB/A,VXE2,VXE2/A,VXE4,VXE6,VXE7,VXE7/A,VXE8,VXE8/A,VXG,VXK,VXQ4,VXQ4/A,VXU,VXU/A,VXU1,VXU1/A,VX16,VX16/A,VX8,VX8/A
			1	-	-	3105643	-----
			-	(1)	1		
17	94109-12000	WASHER, DRAIN PLUG, 12MM ----	2	2	2		



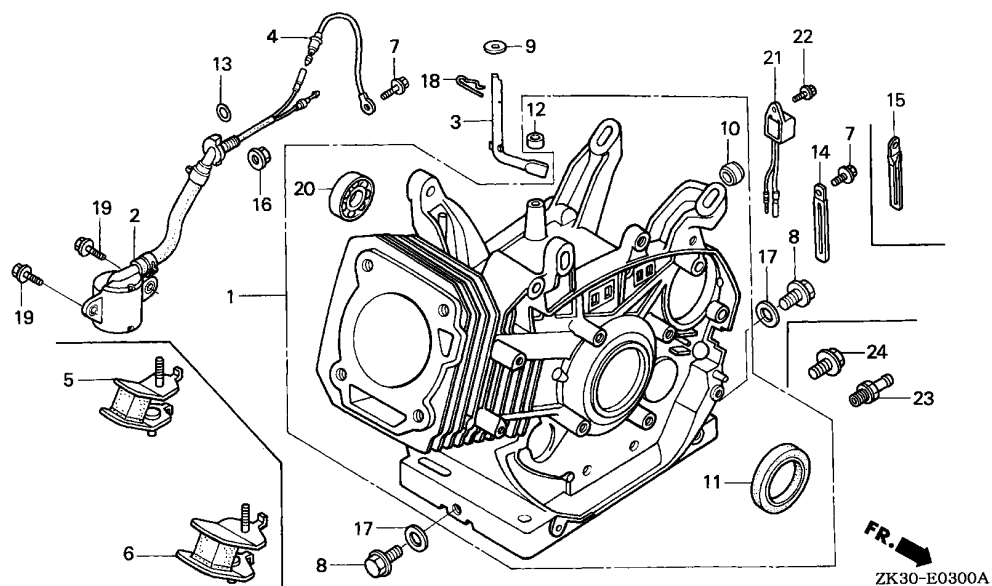

Ref. No.	Part No.	Description	Reqd. QTY			Serial No.	Parts catalogue code
			GX	340K1			
			(1)	(2)	(3)		
18	94251-08000	PIN, LOCK, 8MM .....	1	1	-	2367047	BJ,EDS1,EDT1,LJ,LJG,L1,P1,Q1,SDE,SJ,SJG,STJ,STP,STQ,S1,V1,YJ,ZK1
			1	-	-	2366663	EDN,EDS,EDS3,EDS5,ED7,ED8,ED9,EN,ES,ES1,ES3,ES4,ET,ETS,ETX,HA,HAQ HH,HX,LH,LHC,LHE,LKE,LX,LXE,LXZ,PX,QA,QAE,QAP,QAPE,QAQ,QE,QH,QHC QHE,QNE,QNE9,QN18,QP,QT,QX,QXB,QXC,QXE,QXEB,SE,SH,SHE,SHEZ,SHT SWX,SX,SXB,SXE,SXEB,SXP,VA,VAA,VAE,VAH1,VAH2,VAW1,VDE,VE,VH,VHE VNG,VNG1,VNG2,VWA,VX,VXA,VXB,VXE,VXEB,VXG,VXU,VXU1
			1	-	-	2366735	LHQ4,LXE4,LXQ4,QHQ4,QMED,QXC4,QXE4,QXQ4,SHQ4,SMED,SXE4,SXQ4,VXE4 VXQ4

Ref. No.	Part No.	Description	Reqd. QTY			Serial No.	Parts catalogue code
			(1)	(2)	(3)		
18)	94251-10000	PIN, LOCK, 10MM .....	1	1	-		EDE2,EDE2/A,EDK,EDN2,EDN2/A,EDN5,EDN5/A,EDS1/A,EDS2,EDS2/A,EDS4,EDS6,EDS6/A,EDT,EDT/A,EDT1/A,EDT2,EDT3,EDT6,EDT6/A,ED6,ED6/A,ED8/A,ED9/A,EMT,EMT/A,ENT,ENT/A,ENT2,EN6,EN6/A,ES1/A,ES2,ES3/A,ES4/A,HA2,HA2/A,HX2,HX26,HX26/A,LH/A,LHB1,LHB3,LHB3/A,LHB5,LHE/A,LHQ4/A,LHW,LJ/A,LJG/A,LJS,LJS/A,LJS1,LKE/A,LSX,LT,LT/A,LWD,LWD1,LWD1/A,LX/A,LXE/A,LXE2,LXE2/A,LXE4/A,LXE6,LXE8,LXE8/A,LXQ4/A,LXU,LXU/A,LX2,LX2/A,LX26,LX26/A,L1/A,PKT2,PKT2/A,PKT4,PKT4/A,PKX2,PKX4,PKX4/A,PX/A,PXA2,PXE8,PXE8/A,P1/A,QAB2,QAB2/A,QAC2,QAC2/A,QAE2,QAE2/A,QAE6,QAE6/A,QAG,QAG/A,QA2,QA2/A,QAP2,QAP2/A,QA2,QA2/A,QA26,QA26/A,QDW9,QDW9/A,QE/A,QH/A,QHB3,QHB3/A,QHB5,QHE/A,QHP1,QHP1/A,QHQ4/A,QH2,QKA4,QKA4/A,QL2,QMEO/A,QME8,QME8/A,QMH,QMH/A,QMT2,QMT2/A,QMX2,QNE2,QNE2/A,QNE6,QNE9/A,QNR2,QNR2/A,QNR6,QNR6/A,QP/A,QPE2,QT/A,QTC2,QTC2/A,QWH2,QWH2/A,QX/A,QXB/A,QXB7,QXB7/A,QXC/A,QXC4/A,QXC6,QXC6/A,QXC9,QXC9/A,QXE/A,QXE2,QXE4/A,QXE6,QXE6/A,QXE8,QXE8/A,QXQ4/A,QXU,QXU/A,QX2,Q1/A,SE/A,SH/A,SHB1,SHB3,SHB3/A,SHQ4/A,SJ/A,SJG/A,SKE,SKE/A,SKZ,SKZ/A,SME0/A,SME2,SME2/A,SMX2,SMX2/A,STJ/A,STP/A,STQ/A,STR,STR/A,SWX/A,SWX/A,SWX/A,SWX7,SWX7/A,SXE/A,SXEB/A,SXE2,SXE4/A,SXE8,SXE8/A,SXQ4/A,SXU,SXU/A,S1/A,VAD2,VAD2/A,VA2,VA2/A,VC2,VC2/A,VDE2,VDE2/A,VD16,VEB6,VH12/VH12/A,VH22,VH22/A,VMQ,VMT,VMT/A,VMX,VSH7,VS2,VS3,VS4,VS5,VS6,VS7,VTE2,VWA2,VWC2,VWC2/A,VWE,VWE2,VWE2/A,VWS2,VWS2/A,VW12,VW12/A,VX/A,VXB/A,VXB2,VXB7,VXB7/A,VXE/A,VXEB/A,VXE2,VXE2/A,VXE6,VXE7,VXE7/A,VXE8,VXE8/A,VXK,VXQ4/A,VXU/A,VXU1/A,VX16,VX16/A,VX8,VX8/A,ZK1/A
			1	1	-	2367048	BJ,EDS1,EDT1,LJ,LJG,L1,P1,Q1,SDE,SJ,SJG,STJ,STP,STQ,S1,V1,YJ,ZK1
			1	-	-	2366664	EDN,EDS,EDS3,EDS5,ED7,ED8,ED9,EN,ES,ES1,ES3,ES4,ET,ETX,HA,HAQ,HH,HX,LH,LHC,LHE,LKE,LX,LXE,LXZ,PX,QA,QAE,QAP,QAPE,QAQ,QE,QH,QHC,QHE,QNE,QNE9,QN18,QP,QT,QX,QXB,QXC,QXE,QXE8,SE,SH,SHE,SHEZ,SHT,SWX,SWX,A,SWX,SXB,SXE,SXEB,SXP,VA,VAA,VAAE,VAH1,VAH2,VAW1,VDE,VE,VH,VHE,VNG,VNG1,VNG2,VWA,VX,VXA,VXB,VXE,VXEB,VXG,VXU,VXU1
			1	-	-	2366736	LHQ4,LXE4,LXQ4,QHQ4,QMEO,QXC4,QXE4,QXQ4,SHQ4,SME0,SXE4,SXQ4,VXE4,VXQ4
			-	-	1		
19	95701-06012-00	BOLT, FLANGE, 6X12 .....	2	-	-		EDE2,EDE2/A,EDK,EDN,EDN2,EDN2/A,EDN5,EDN5/A,EDS,EDS1,EDS1/A,EDS2,EDS2/A,EDS3,EDS4,EDS5,EDS6,EDS6/A,EDT,EDT/A,EDT1,EDT1/A,EDT2,EDT3,EDT6,EDT6/A,ED6,ED6/A,ED9,ED9/A,EMT,EMT/A,ENT,ENT/A,ENT2,EN6,EN6/A,ES1,ES1/A,ES2,ES3,ES3/A,ES4,ES4/A,ETS,ETX,HA,HAQ,HA2,HA2/A,HX,HX2,HX26,HX26/A,LKE,LKE/A,LSX,LX,LX/A,LXE,LXE/A,LXE2,LXE2/A,LXE4,LXE4/A,LXE6,LXE8,LXE8/A,LXQ4,LXQ4/A,LXU,LXU/A,LX2,LX2/A,LX26,LX26/A,PKT2,PKT2/A,PKT4,PKT4/A,PKX2,PKX4,PKX4/A,PX,PX/A,PXA2,PXE8,PXE8/A,QA,QAB2,QAB2/A,QAC2,QAC2/A,QAE,QAE2/A,QAE6,QAE6/A,QAG,QAG/A,QA2,QA2/A,QAP2,QAP2/A,QAQ,QA2,QA2/A,QA26,QA26/A,QDW9,QDW9/A,QKA4/A,QL2,QMEO,QMEO/A,QME8,QME8/A,QMT2,QMT2/A,QMX2,QNE,QNE2,QNE2/A,QNE6,QNE9,QNE9/A,QNR2,QNR2/A,QNR6,QNR6/A,QN18,QPE2,QTC2,QTC2/A,QWH2,QWH2/A,QX,QX/A,QXB,QXB/A,QXB7,QXB7/A,QXC,QXC/A,QXC4,QXC4/A,QXC6,QXC6/A,QXC9,QXC9/A,QXE,QXE/A,QXE2,QXE2,QXE4,QXE4/A,QXE6,QXE6/A,QXE8,QXE8/A,QXQ4,QXQ4/A,QXU,QXU/A,QX2,SHT,SME0,SME0/A,SME2,SMX2,SMX2/A,STJ,STJ/A,SWX,SWX/A,SWX/A,SWX7,SWX7/A,SXE,SXE/A,SXEB,SXEB/A,SXE2,SXE4,SXE4/A,SXE8,SXE8/A,SXP,SXQ4,SXQ4/A,SXU,SXU/A,VA,VAA,VAAE,VAD2,VAD2/A,VAH1,VAH2,VAW1,VA2,VA2/A,VC2,VC2/A,VDE,VDE2,VDE2/A,VD16,VEB6,VH12,VH12/A,VH22,VH22/A,VMQ,VMT,VMT/A,VMX,VNG,VNG1,VNG2,VSH7,VS2,VS3,VS4,VS5,VS6,VS7,VWA,VWA2,VWC,VWC2,VWC2/A,VWE,VWE2,VWE2/A,VWS2,VWS2/A,VW12,VW12/A,VX,VX/A,VXA,VXB,VXB/A,VXB2,VXB7,VXB7/A,VXE,VXE/A,VXEB,VXEB/A,VXE2,VXE2/A,VXE4,VXE6,VXE7,VXE7/A,VXE8,VXE8/A,VXG,VXK,VXQ4,VXQ4/A,VXU,VXU/A,VXU1,VXU1/A,VX16,VX16/A,VX8,VX8/A
			2	-	-	3105643	QKA4
			-	(2)	2		
20	96100-62020-00	BEARING, RADIAL BALL, 6202 ..	1	1	1		



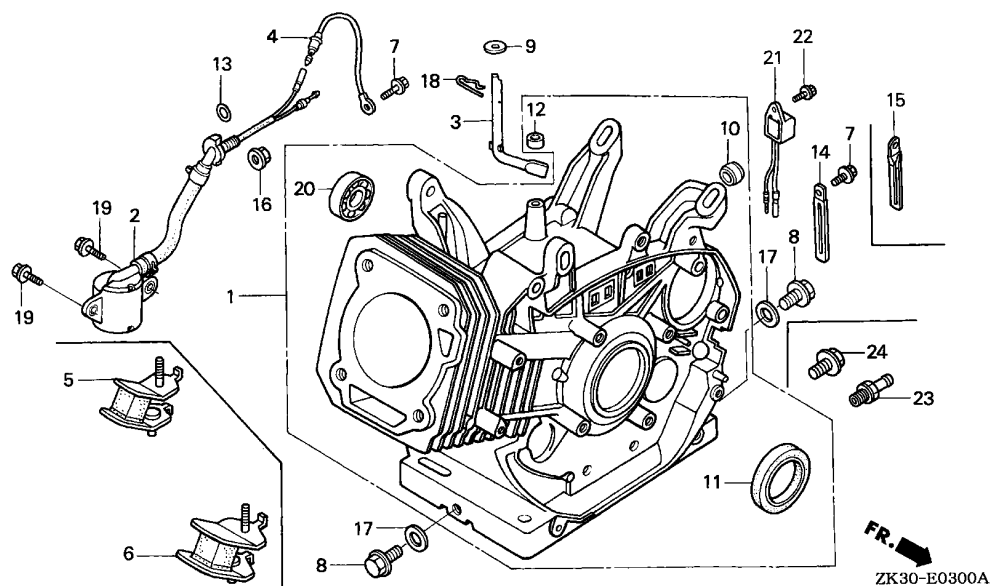

Ref. No.	Part No.	Description	Reqd. QTY			Serial No.	Parts catalogue code	
			GX	340K1				
			(1)	(2)	(3)			
21	34150-ZH7-003	ALERT UNIT, OIL .....	1	(1)	-	-----	EDE2/A,EDN2/A,EDN5/A,EDS2/A,EDS6,EDS6/A,EDT,EDT/A,EDT6,EDT6/A,ED6/A,EMT,ENT,ENT/A,ENT2,EN6,EN6/A,HA2/A,HX26/A,LXQ4/A,LXU,LXU/A,LX2/A,LX26/A,PKT2/A,PKT4,PKT4/A,PKX2,PKX4,PKX4/A,PXA2,P1/A,QAB2,QAB2/A,QAC2,QAC2/A,QAG,QAG/A,QA2/A,QAP2/A,QA2/A,QA26/A,QDW9/A,QKA4/A,QMT2/A,QTC2/A,QWH2,QWH2/A,QXB/A,QXB7,QXB7/A,QXC/A,QXC4/A,QXC6/A,QXC9/A,QXQ4/A,QXU,QXU/A,Q1/A,SMX2/A,SWX/A,SXB/A,SXB7,SXB7/A,SXQ4/A,SXU,SXU/A,VAD2/A,VA2/A,VC2,VC2/A,VDE2/A,VH12/A,VMT,VSH7,VWC,VWC2/A,VWE,VWS2/A,VW12/A,VXB/A,VXB7,VXB7/A,VXQ4/A,VX16/A,VX8,VX8/A	
			1	(1)	-	2801238	-----	EDE2,EDN,EDN2,EDN5,EDS,EDS1,EDS2,EDS3,EDS5,EDT1,EDT2,ED6,ED9,ES1,ES3,ES4,HA2,HX2,HX26,LSX,LX,LXQ4,LX2,LX26,L1,PKT2,PX,P1,QA2,QAP2,QA2,QA26,QDW9,QMT2,QMX2,QTC2,QX,QXB,QXC,QXC4,QXC6,QXC9,QXQ4,Q1,SMX2,STJ,SWX,SX,SXB,SXQ4,S1,VAD2,VA2,VDE2,VH12,VMX,VWA2,VWC2,VMS2,VW12,VX,VXB,VXQ4,VXU,VX16
			1	(1)	-	4074558	-----	EDK,EDS1/A,EDS4,EDT1/A,ED9/A,EMT/A,ES1/A,ES3/A,ES4/A,LX/A,L1/A,PX/A,QX/A,STJ/A,SX/A,S1/A,VMQ,VMT/A,VS3,VS4,VS5,VS6,VX/A,VXK,VXU/A
			1	-	-	3105643	-----	QKA4
			-	-	1			
	34150-ZH7-013	.....	1	(1)	-	4074559	-----	EDK,EDS1/A,EDS4,EDT1/A,ED9/A,EMT/A,ES1/A,ES3/A,ES4/A,LX/A,L1/A,PX/A,QX/A,STJ/A,SX/A,S1/A,VMQ,VMT/A,VS3,VS4,VS5,VS6,VX/A,VXK,VXU/A
			1	-	-	-----	-----	EDT3,ES2,VS2,VS7

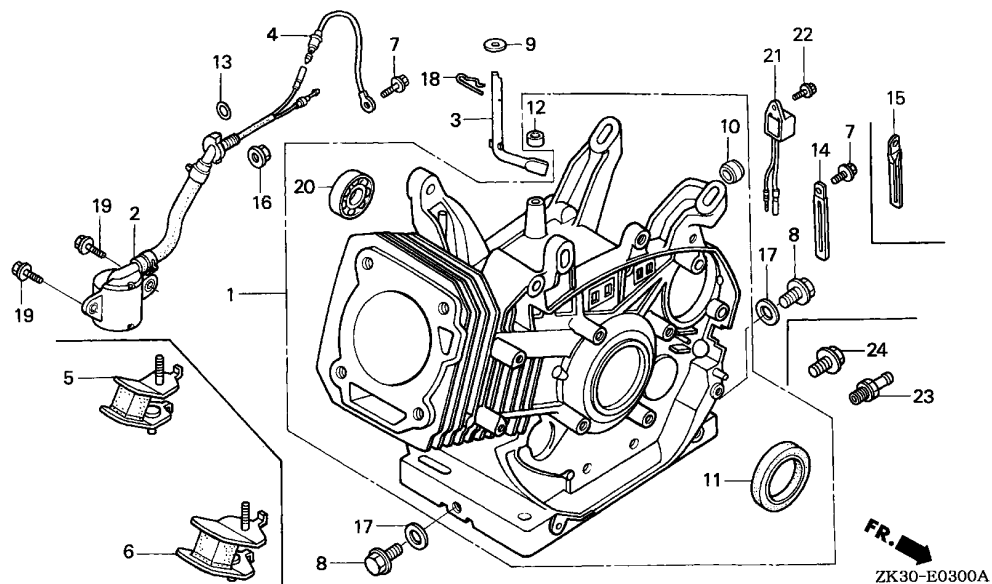

Ref. No.	Part No.	Description	Reqd. QTY			Serial No.	Parts catalogue code	
			GX	(1)	(2)			(3)
22	90013-883-000	BOLT, FLANGE, 6X12(CT200) ...	1	(1)	-	-----	EDE2/A,EDK,EDN2/A,EDN5/A,EDS1/A,EDS2/A,EDS4,EDS6,EDS6/A,EDT,EDT/A,EDT1/A,EDT3,EDT6,EDT6/A,ED6/A,ED9/A,EMT,EMT/A,ENT,ENT/A,ENT2,EN6,EN6/A,ES1/A,ES2,ES3/A,ES4/A,HA2/A,HX26/A,LX/A,LXQ4/A,LXU,LXU/A,LX2/A,LX26/A,L1/A,PKT2/A,PKT4,PKT4/A,PKX2,PKX4,PKX4/A,PX/A,PXA2,P1/A,QAB2,QAB2/A,QAC2,QAC2/A,QAG,QAG/A,QA2/A,QA2/A,QA26/A,QA26/A,QDW9/A,QKA4/A,QMT2/A,QTC2/A,QWH2,QWH2/A,QX/A,QXB/A,QXB7,QXB7/A,QXC/A,QXC4/A,QXC6/A,QXC9/A,QXQ4/A,QXU,QXU/A,Q1/A,SMX2/A,STJ/A,SWX/A,SX/A,SXB/A,SXB7,A,SXB7/A,SXQ4/A,SXU,SXU/A,S1/A,VAD2/A,VA2/A,VC2,VC2/A,VDE2/A,VH12/A,VMQ,VMT,VMT/A,VSH7,VS2,VS3,VS4,VS5,VS6,VS7,VWC,VWC2/A,VWE,VWS2/A,VW12/A,VX/A,VXB/A,VXB7,VXB7/A,VXK,VXQ4/A,VXU/A,VX16/A,VX8,VX8/A	
			1	(1)	-	2801238	-----	EDE2,EDN,EDN2,EDN5,EDS,EDS1,EDS2,EDS3,EDS5,EDT1,EDT2,ED6,ED9,ES1,ES3,ES4,HA2,HX2,HX26,LSX,LX,LXQ4,LX2,LX26,L1,PKT2,PX,P1,QA2,QA2,QA26,QDW9,QMT2,QMX2,QTC2,QX,QXB,QXC,QXC4,QXC6,QXC9,QXQ4,Q1,SMX2,STJ,SWX,SX,SXB,SXQ4,S1,VAD2,VA2,VDE2,VH12,VMX,VWA2,VWC2,VWS2,VW12,VX,VXB,VXQ4,VXU,VX16
			1	-	-	3105643	-----	QKA4
23	90131-ZE3-790	PLUG, OIL DRAIN .....	1	-	-	-----	2362399	ZK1
24	92800-12000	BOLT, DRAIN PLUG, 12MM .....	1	-	-	-----	-----	ZK1,ZK1/A

E-6

CRANKCASE COVER(1)

F14

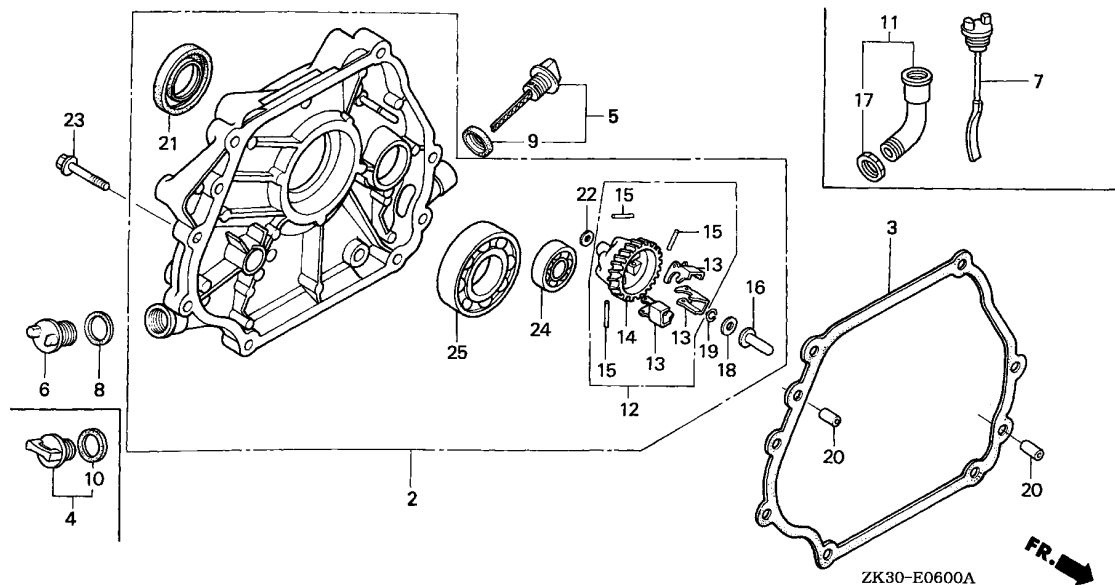

Ref. No.	L.O.N.	(Relative ref. Number) Description	F.R.T.
2	1101F1	COVER, CRANKCASE .....	0.2
3	1101E9	PACKING, CRANKCASE COVER .....	0.2
11	1101B9	EXTENSION, OIL FILLER AND/OR PACKING, OIL FILLER EXTENSION (13)	0.1
14	1161A7	HOLDER, GOVERNOR WEIGHT .....	0.3
16	1161B6	SLIDER, GOVERNOR .....	0.3
21	1101E5	OIL SEAL, CRANKSHAFT :REAR ...	0.3
24	1101F5	BEARING, BALANCER WEIGHT :REAR	0.4
25	1101A6	BEARING, CRANKSHAFT :REAR ....	0.4

Ref. No.	Part No.	Description	Reqd. QTY			Serial No.	Parts catalogue code
			GX	(1)	(2)		
2	11300-ZE3-020	COVER ASSY., CRANKCASE .....	1	-	-	-----	EDN,EDS,EDS3,EDS5,EDT2,ED7,EN,SDE,SHB1,SHE,SHEZ,SHT,SME2,SXE2 VTE2,YJ
			1	-	-	3460754	EDE2,EDN2,EDN5,EDS1,EDS2,EDS6,EDT,EDT1,EDT6,ED6,ED8,ED9,ENT,EN6 SE,SH,SHB3,SHQ4,SJ,SJG,SKE,SKZ,SME0,SMX2,STJ,STP,STQ,STR,SWX,SX SXB,SXE,SXEB,SXE4,SXE8,SXQ4,SXU
	11300-ZE3-602	.....	1	1	-	-----	QA,QAE,QAP,QAPE,QAQ,QHC,QH2,QL2,QMX2,QNE,QNE6,QN18,QPE2,QXEB,QXE2 QX2,SXP,VA,VAA,VAAE,VAH1,VAH2,VAW1,VDE,VD16,VE,VEB6,VH,VHE,VMX VNG,VNG1,VNG2,VWA,VWA2,VXA,VXB2,VXE4,VXE6,VXG,V1
			1	-	-	3460754	PKT2,PKT4,PKX4,PX,PXE8,QAB2,QAC2,QAE2,QAE6,QAG,QAH2,QAP2,QA2,QA26 QDW9,QE,QH,QHB3,QHE,QHP1,QHQ4,QKA4,QME0,QME8,QMH,QMT2,QNE2,QNE9 QNR2,QNR6,QP,QT,QTC2,QWH2,QX,QXB,QXC,QXC4,QXC6,QXC9,QXE,QXE4,QXE6 QXE8,QXQ4,QXU,VAD2,VA2,VC2,VDE2,VH12,VH22,VWC2,VWE2,VWS2,VW12,VX VXB,VXE,VXEB,VXE2,VXE8,VXQ4,VXU,VXU1,VX16,VX8
	11300-ZE3-U40	.....	-	-	1	-----	ET,ETS,ETX
	11300-ZE3-040	.....	1	1	-	-----	EDE2/A,EDK,EDN2/A,EDN5/A,EDS1/A,EDS2/A,EDS4,EDS6/A,EDT/A,EDT1/A EDT3,EDT6/A,ED6/A,ED8/A,ED9/A,ENT/A,ENT2,EN6/A,PKX2,SE/A,SH/A SHB3/A,SHQ4/A,SJ/A,SJG/A,SKE/A,SKZ/A,SME0/A,SMX2/A,STJ/A,STP/A STQ/A,STR/A,SWX/A,SX/A,SXB/A,SXB7/A,SXE/A,SXEB/A,SXE4/A SXE8/A,SXQ4/A,SXU/A,S1,S1/A
			1	-	-	3460755	EDE2,EDN2,EDN5,EDS1,EDS2,EDS6,EDT,EDT1,EDT6,ED6,ED8,ED9,ENT,EN6 SE,SH,SHB3,SHQ4,SJ,SJG,SKE,SKZ,SME0,SMX2,STJ,STP,STQ,STR,SWX,SX SXB,SXE,SXEB,SXE4,SXE8,SXQ4,SXU



Ref. No.	Part No.	Description	Reqd. QTY			Serial No.	Parts catalogue code	
			(1)	(2)	(3)			
(2)	11300-ZE3-604	COVER ASSY., CRANKCASE .....	1	1	-	-----	PKT2/A,PKT4/A,PX/A,PXA2,PXE8/A,P1,P1/A,QAB2/A,QAC2/A,QAE2/A,QAE6/A,QAG/A,QA2/A,QAH2/A,QAP2/A,QA2/A,QA26/A,QDW9/A,QE/A,QH/A,QHB3/A,QHB5,QHE/A,QHP1/A,QHQ4/A,QKA4/A,QMEO/A,QME8/A,QMH/A,QMT2/A,QNE2/A,QNE9/A,QNR2/A,QNR6/A,QP/A,QT/A,QTC2/A,QWH2/A,QX/A,QXB/A,QXB7/QXB7/A,QXC/A,QXC4/A,QXC6/A,QXC9/A,QXE/A,QXE4/A,QXE6/A,QXE8/A,QXQ4/A,QXU/A,Q1,Q1/A,VAD2/A,VA2/A,VC2/A,VDE2/A,VH12/A,VH22/A,VMQ/VMT/VMT/A,VSH7,VWC,VWC2/A,VWE,VWE2/A,VWS2/A,VW12/A,VX/A,VXB/A,VXB7,VXB7/A,VXE/A,VXEB/A,VXE2/A,VXE7,VXE7/A,VXE8/A,VXK,VXQ4/A/VXU/A,VXU1/A,VX16/A,VX8/A	
			1	-	-	3460755	-----	PKT2,PKT4,PKX4,PX,PXE8,QAB2,QAC2,QAE2,QAE6,QAG,QA2,QAP2,QA2,QA26,QDW9,QE,QH,QHB3,QHE,QHP1,QHQ4,QKA4,QMEO,QME8,QMH,QMT2,QNE2,QNE9,QNR2,QNR6,QP,QT,QTC2,QWH2,QX,QXB,QXC,QXC4,QXC6,QXC9,QXE,QXE4,QXE6,QXE8,QXQ4,QXU,VAD2,VA2,VC2,VDE2,VH12,VH22,VWC2,VWE2,VWS2,VW12,VX,VXB,VXE,VXEB,VXE2,VXE8,VXQ4,VXU,VXU1,VX16,VX8
	11300-ZE3-040	.....	1	-	-	3681345	-----	PKX4/A
	11300-ZE3-P70	.....	1	-	-	3681346	-----	PKX4/A
3	11381-ZE3-801	PACKING, CASE COVER .....	1	(1)	-	-----	-----	VS2,VS3,VS4,VS5,VS6,VS7 EDE2,EDE2/A,EDK,EDN,EDN2,EDN2/A,EDN5,EDN5/A,EDS,EDS1,EDS1/A,EDS2,EDS2/A,EDS3,EDS4,EDS5,EDS6/A,EDT,EDT1/A,EDT1/A,EDT2,EDT3,EDT6,EDT6/A,ED6,ED6/A,ED7,ED8,ED8/A,ED9,ED9/A,EN,ENT,ENT/A,ENT2,EN6,EN6/A,ET,ETS,ETX,PKT2,PKT2/A,PKT4,PKT4/A,PKX2,PKX4,PKX4/A,PX,PX/A,PXA2,PXE8,PXE8/A,P1,P1/A,QA,QAB2,QAB2/A,QAC2,QAC2/A,QAE,QAE2,QAE2/A,QAE6,QAE6/A,QAG,QAG/A,QA2,QA2/A,QAH2,QA2/A,QAP,QAPE,QAP2,QAP2/A,QA2,QA2/A,QA26,QA26/A,QDW9,QDW9/A,QE,QE/A,QH,QH/A,QHB3,QHB3/A,QHB5,QHC,QHE,QHE/A,QHP1,QHP1/A,QHQ4,QHQ4/A,QH2,QKA4,QKA4/A,QL2,QMEO,QMEO/A,QME8,QME8/A,QMH,QMH/A,QMT2,QMT2/A,QMX2,QNE,QNE2,QNE2/A,QNE6,QNE9,QNE9/A,QNR2,QNR2/A,QNR6,QNR6/A,QN18,QP,QP/A,QPE2,QT,QT/A,QTC2,QTC2/A,QWH2,QWH2/A,QX,QX/A,QXB,QXB/A,QXB7,QXB7/A,QXC,QXC/A,QXC4,QXC4/A,QXC6,QXC6/A,QXC9,QXC9/A,QXE,QXE/A,QXEB,QXE2,QXE4,QXE4/A,QXE6,QXE6/A,QXE8,QXE8/A,QXQ4,QXQ4/A,QXU,QXU/A,QX2,Q1,Q1/A,SDE,SE,SE/A,SH,SH/A,SHB1,SHB3,SHB3/A,SHE,SHE2,SHQ4,SHQ4/A,SHT,SJ,SJ/A,SJG,SJG/A,SKE,SKE/A,SKZ,SKZ/A,SME0,SME0/A,SME2,SMX2,SMX2/A,STJ,STJ/A,STP,STP/A,STQ,STQ/A,STR,STR/A,SWX,SWX/A,SX,SX/A,SXB,SXB/A,SXB7,SXB7/A,SXE,SXE/A,SXEB,SXEB/A,SXE2,SXE4,SXE4/A,SXE8,SXE8/A,SXP,SXQ4,SXQ4/A,SXU,SXU/A,S1,S1/A,VA,VAA,VAE,VAD2,VAD2/A,VAH1,VAH2,VAW1,VA2,VA2/A,VC2,VC2/A,VDE,VDE2,VDE2/A,VD16,VE,VEB6,VH,VHE,VH12,VH12/A,VH22,VH22/A,VMQ,VMX,VNG,VNG1,VNG2,VSH7,VS2,VS3,VS4,VS5,VS6,VS7,VTE2,VWA,VWA2,VWC,VWC2,VWC2/A,VWE,VWE2,VWE2/A,VWS2,VWS2/A,VW12,VW12/A,VX,VX/A,VXA,VXB,VXB/A,VXB2,VXB7,VXB7/A,VXE,VXE/A,VXEB,VXEB/A,VXE2,VXE2/A,VXE4,VXE4,VXE7,VXE7/A,VXE8,VXE8/A,VXG,VXK,VXQ4,VXQ4/A,VXU,VXU/A,VXU1,VXU1/A,VX16,VX16/A,VX8,VX8/A,V1,YJ
			-	-	1			



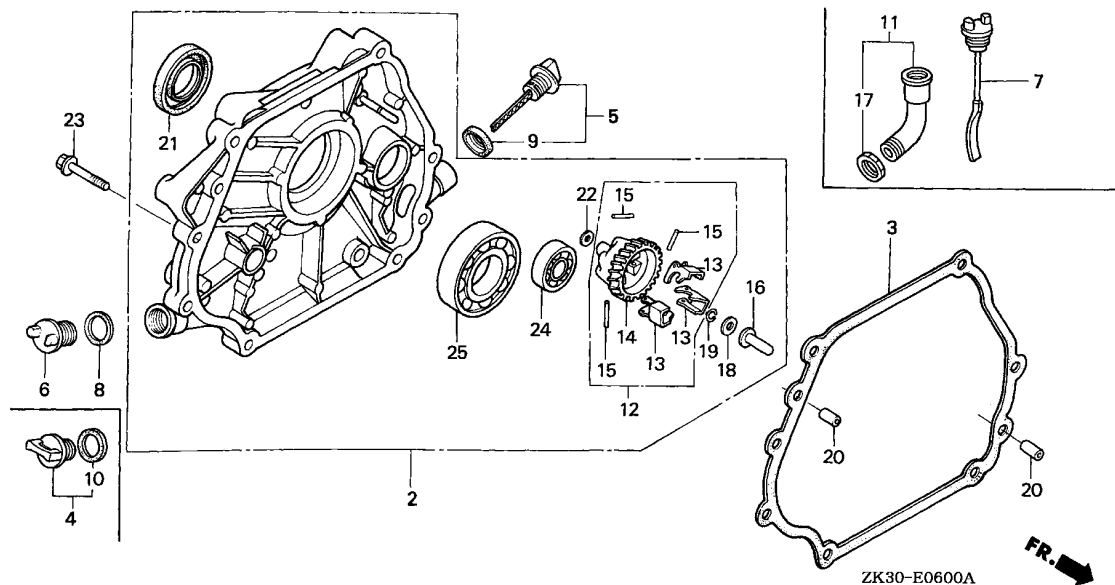

Ref. No.	Part No.	Description	Reqd. QTY			Serial No.	Parts catalogue code
			GX	340K1			
			(1)	(2)	(3)		
4	15600-ZG4-003	CAP ASSY., OIL FILLER .....	1	1	-	-----	EDE2,EDE2/A,EDK,EDN2,EDN2/A,EDN5,EDN5/A,EDS1/A,EDS2,EDS2/A,EDS3,EDS4,EDS5,EDS6,EDS6/A,EDT,EDT/A,EDT1/A,EDT2,EDT3,EDT6,EDT6/A,ED6/A,ED8/A,ED9/A,ENT,ENT/A,ENT2,EN6,EN6/A,PKT2,PKT2/A,PKT4,PKT4/A,PKX2,PKX4,PKX4/A,PX/A,PXA2,PXE8,PXE8/A,P1/A,QAB2,QAB2/A,QAC2,QAC2/A,QAE2,QAE2/A,QAE6,QAE6/A,QAG,QAG/A,QA2,QA2/A,QAP,QAPE,QAP2,QAP2/A,QA2,QA2/A,QA26,QA26/A,QDW9,QDW9/A,QE/A,QH/A,QHB3,QHB3/A,QHB5,QHE/A,QHP1,QHP1/A,QHQ4,QHQ4/A,QH2,QKA4,QKA4/A,QL2,QME0,QME0/A,QME8,QME8/A,QMH,QMH/A,QMT2,QMT2/A,QMX2,QNE2,QNE2/A,QNE6,QNE9/A,QNR2,QNR2/A,QNR6,QNR6/A,QN18,QP/A,QPE2,QT/A,QTC2,QTC2/A,QWH2,QWH2/A,QX/A,QXB/A,QXB7/A,QXC/A,QXC4,QXC4/A,QXC6,QXC6/A,QXC9,QXC9/A,QXE/A,QXE2,QXE4,QXE4/A,QXE6,QXE6/A,QXE8,QXE8/A,QXQ4,QXQ4/A,QXU,QXU/A,QX2,Q1/A,SDE,SE/A,SH/A,SHB1,SHB3,SHB3/A,SHQ4,SHQ4/A,SHT,SJ/A,SJG,SJG/A,SKE,SKE/A,SKZ,SKZ/A,SME0,SME0/A,SME2,SMX2,SMX2/A,STJ/A,STP/A,STQ/A,STR,STR/A,SWX/A,SWX/A,SXB7,SXB7/A,SXE/A,SXEB/A,SXE2,SXE4,SXE4/A,SXE8,SXE8/A,SXQ4,SXQ4/A,SXU,SXU/A,S1/A,VAD2,VAD2/A,VAH1,VAH2,VAW1,VA2,VA2/A,VC2,VC2/A,VDE,VDE2,VDE2/A,VD16,VDE6,VH12,VH12/A,VH22,VH22/A,VMQ,VMX,VSH7,VS2,VS3,VS4,VS5,VS6,VS7,VTE2,VVA,VVA2,VWC,VWC2,VWC2/A,VWE,VWE2,VWE2/A,VWS2,VWS2/A,VW12,VW12/A,VX/A,VXB/A,VXB2,VXB7,VXB7/A,VXE/A,VXEB/A,VXE2,VXE2/A,VXE4,VXE6,VXE7,VXE7/A,VXE8,VXE8/A,VXG,VXK,VXQ4,VXQ4/A,VXU,VXU/A,VXU1,VXU1/A,VX16,VX16/A,VX8,VX8/A
			1	1	-	2259155 -----	EDN,EDS,ED6,ED7,ED8,ED9,EN,ET,ETS,ETX,PX,P1,QA,QAE,QAQ,QE,QH,QHC,QHE,QNE,QNE9,QP,QT,QX,QXB,QXC,QXE,QXEB,Q1,SE,SH,SHE,SHEZ,SJ,STJ,STP,STQ,SWX,SX,SXB,SXE,SXEB,SXP,S1,VA,VAA,VAAE,VE,VH,VHE,VNG,VNG1,VNG2,VX,VXA,VXB,VXE,VXEB,V1,YJ
			1	-	-	2258974 -----	EDS1,EDT1
			-	-	1		

Ref. No.	Part No.	Description	Reqd. QTY			Serial No.	Parts catalogue code
			(1)	(2)	(3)		
5	15600-735-003	CAP ASSY., OIL FILLER .....	1	1	-	-----	EDE2,EDE2/A,EDK,EDN,EDN2,EDN2/A,EDN5,EDN5/A,EDS,EDS1,EDS1/A,EDS2,EDS2/A,EDS3,EDS4,EDS5,EDS6,EDS6/A,EDT,EDT/A,EDT1,EDT1/A,EDT2,EDT3,EDT6,EDT6/A,ED6,ED6/A,ED7,ED8,ED8/A,ED9,ED9/A,EN,ENT,ENT/A,ENT2,EN6,EN6/A,ET,ETS,ETX,PKT2,PKT2/A,PKT4,PKT4/A,PKX2,PKX4,PKX4/A,PX,PX/A,PXA2,PXE8,PXE8/A,P1,P1/A,QA,QAB2,QAB2/A,QAC2,QAC2/A,QAQ,QAQ2,QAQ2/A,QAQ6,QAQ6/A,QAG,QAG/A,QAQ2,QAQ2/A,QAP,QAPE,QAP2,QAP2/A,QAQ,QA2,QA2/A,QA26,QA26/A,QDW9,QDW9/A,QE,QE/A,QH,QH/A,QHB3,QHB3/A,QHB5,QHC,QHE,QHE/A,QHP1,QHP1/A,QHQ4,QHQ4/A,QH2,QKA4,QKA4/A,QL2,QMEO,QMEO/A,QME8,QME8/A,QMH,QMH/A,QMT2,QMT2/A,QMX2,QNE,QNE2,QNE2/A,QNE6,QNE9,QNE9/A,QNR2,QNR2/A,QNR6,QNR6/A,QN18,QP,QP/A,QPE2,QT,QT/A,QTC2,QTC2/A,QWH2,QWH2/A,QX,QX/A,QXB,QXB/A,QXB7,QXB7/A,QXC,QXC/A,QXC4,QXC4/A,QXC6,QXC6/A,QXC9,QXC9/A,QXE,QXE/A,QXEB,QXE2,QXE4,QXE4/A,QXE6,QXE6/A,QXE8,QXE8/A,QXQ4,QXQ4/A,QXU,QXU/A,QX2,Q1,Q1/A,SDE,SE,SE/A,SH,SH/A,SHB1,SHB3,SHB3/A,SHE,SHEZ,SHQ4,SHQ4/A,SHT,SJ,SJ/A,SJG,SJG/A,SKE,SKE/A,SKZ,SKZ/A,SME0,SME0/A,SME2,SMX2,SMX2/A,STJ,STJ/A,STP,STP/A,STQ,STQ/A,STR,STR/A,SWX,SWX/A,SX,SX/A,SXB,SXB/A,SXB7,SXB7/A,SXE,SXE/A,SXEB,SXEB/A,SXE2,SXE4,SXE4/A,SXE8,SXE8/A,SXP,SXQ4,SXQ4/A,SXU,SXU/A,S1,S1/A,VA,VAA,VAAE,VAD2,VAD2/A,VAH1,VAH2,VAW1,VA2,VA2/A,VC2,VC2/A,VDE,VDE2,VDE2/A,VD16,VE,VEB6,VH,VHE,VH12,VH12/A,VH22,VH22/A,VMQ,VMX,VNG,VNG1,VNG2,VSH7,VS2,VS3,VS4,VS5,VS6,VS7,VTE2,VWA,VWA2,VWC,VWC2,VWC2/A,VWE,VWE2,VWE2/A,VWS2,VWS2/A,VW12,VW12/A,VX,VX/A,VXA,VXB,VXB/A,VXB2,VXB7,VXB7/A,VXE,VXE/A,VXEB,VXEB/A,VXE2,VXE2/A,VXE4,VXE6,VXE7,VXE7/A,VXE8,VXE8/A,VXG,VXQ4,VXQ4/A,VXU,VXU/A,VXU1,VXU1/A,VX16,VX16/A,VX8,VX8/A,V1,YJ
			-	-	1		
6	15620-ZG4-910	CAP, OIL FILLER .....	1	1	-	-----	2259154 EDN,EDS,ED6,ED7,ED8,ED9,EN,ET,ETS,ETX,PX,P1,QA,QAQ,QAQ,QAQ,QE,QH,QHC,QHE,QNE,QNE9,QP,QT,QX,QXB,QXC,QXE,QXEB,Q1,SE,SH,SHE,SHEZ,SJ,STJ,STP,STQ,SWX,SX,SXB,SXE,SXEB,SXP,S1,VA,VAA,VAAE,VE,VH,VHE,VNG,VNG1,VNG2,VX,VXA,VXB,VXE,VXEB,V1,YJ
			1	-	-	-----	2258973 EDS1,EDT1
7	15620-883-630	CAP COMP., OIL (YELLOW) .....	1	-	-	-----	SHT,STR,STR/A
8	15621-896-010	PACKING, OIL FILLER CAP .....	1	1	-	-----	2259154 EDN,EDS,ED6,ED7,ED8,ED9,EN,ET,ETS,ETX,PX,P1,QA,QAQ,QAQ,QAQ,QE,QH,QHC,QHE,QNE,QNE9,QP,QT,QX,QXB,QXC,QXE,QXEB,Q1,SE,SH,SHE,SHEZ,SJ,STJ,STP,STQ,SWX,SX,SXB,SXE,SXEB,SXP,S1,VA,VAA,VAAE,VE,VH,VHE,VNG,VNG1,VNG2,VX,VXA,VXB,VXE,VXEB,V1,YJ
			1	-	-	-----	2258973 EDS1,EDT1



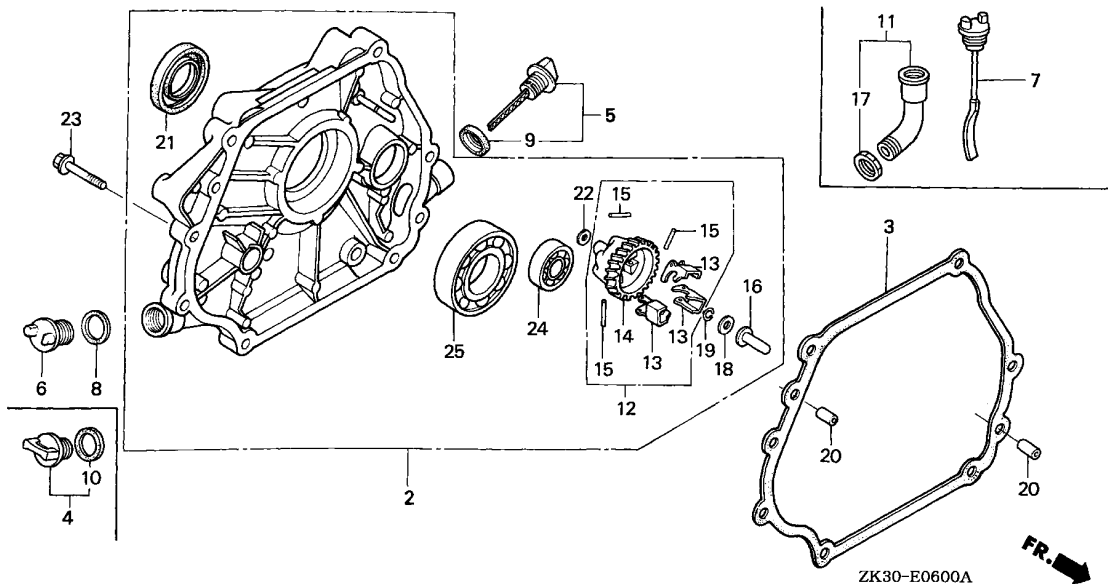

Ref. No.	Part No.	Description	Reqd. QTY			Serial No.	Parts catalogue code
			GX	340K1	(3)		
9	15625-ZE1-003	PACKING, OIL FILLER CAP .....	1	1	-	-----	EDE2,EDE2/A,EDK,EDN,EDN2,EDN2/A,EDN5,EDN5/A,EDS,EDS1,EDS1/A,EDS2,EDS2/A,EDS3,EDS4,EDS5,EDS6,EDS6/A,EDT,EDT/A,EDT1,EDT1/A,EDT2,EDT3,EDT6,EDT6/A,ED6,ED6/A,ED7,ED8,ED8/A,ED9,ED9/A,EN,ENT,ENT/A,ENT2,EN6,EN6/A,ET,ETS,ETX,PKT2,PKT2/A,PKT4,PKT4/A,PKX2,PKX4,PKX4/A,PX,PX/A,PXA2,PXE8,PXE8/A,P1,P1/A,QA,QAB2,QAB2/A,QAC2,QAC2/A,QAE,QAE2,QAE2/A,QAE6,QAE6/A,QAG,QAG/A,QA2,QA2/A,QAP,QAPE,QAP2,QAP2/A,QAQ,QA2,QA2/A,QA26,QA26/A,QDW9,QDW9/A,QE,QE/A,QH,QH/A,QHB3,QHB3/A,QHB5,QHC,QHE,QHE/A,QHP1,QHP1/A,QHQ4,QHQ4/A,QH2,QKA4,QKA4/A,QL2,QME0,QME0/A,QME8,QME8/A,QMH,QMH/A,QMT2,QMT2/A,QMX2,QNE,QNE2,QNE2/A,QNE6,QNE9,QNE9/A,QNR2,QNR2/A,QNR6,QNR6/A,QN18,QP,QP/A,QPE2,QT,QT/A,QTC2,QTC2/A,QWH2,QWH2/A,QX,QX/A,QXB,QXB/A,QXB7,QXB7/A,QXC,QXC/A,QXC4,QXC4/A,QXC6,QXC6/A,QXC9,QXC9/A,QXE,QXE/A,QXEB,QXE2,QXE4,QXE4/A,QXE6,QXE6/A,QXE8,QXE8/A,QXQ4,QXQ4/A,QXU,QXU/A,QX2,Q1,Q1/A,SDE,SE,SE/A,SH,SH/A,SHB1,SHB3,SHB3/A,SHE,SHEZ,SHQ4,SHQ4/A,SHT,SJ,SJ/A,SJ6,SJ6/A,SKE,SKE/A,SKZ,SKZ/A,SME0,SME0/A,SME2,SMX2,SMX2/A,STJ,STJ/A,STP,STP/A,STQ,STQ/A,SWX,SWX/A,SX,SX/A,SXB,SXB/A,SXB7,SXB7/A,SXE,SXE/A,SXEB,SXEB/A,SXE2,SXE4,SXE4/A,SXE8,SXE8/A,SXP,SXQ4,SXQ4/A,SXU,SXU/A,S1,S1/A,VA,VAA,VAAE,VAD2,VAD2/A,VAH1,VAH2,VAW1,VA2,VA2/A,VC2,VC2/A,VDE,VDE2,VDE2/A,VD16,VE,VEB6,VH,VHE,VH12,VH12/A,VH22,VH22/A,VMQ,VMX,VNG,VNG1,VNG2,VSH7,VS2,VS3,VS4,VS5,VS6,VS7,VTE2,VVA,VVA2,VWC,VWC2,VWC2/A,VWE,VWE2,VWE2/A,VWS2,VWS2/A,VW12,VW12/A,VX,VX/A,VXA,VXB,VXB/A,VXB2,VXB7,VXB7/A,VXE,VXE/A,VXEB,VXEB/A,VXE2,VXE2/A,VXE4,VXE6,VXE7,VXE7/A,VXE8,VXE8/A,VXG,VXK,VXQ4,VXQ4/A,VXU,VXU/A,VXU1,VXU1/A,VX16,VX16/A,VX8,VX8/A,V1,YJ
			-	-	1		

Ref. No.	Part No.	Description	Reqd. QTY			Serial No.	Parts catalogue code
			(1)	(2)	(3)		
10	15625-ZE1-003	PACKING, OIL FILLER CAP .....	1	1	-	-----	EDE2,EDE2/A,EDK,EDN2,EDN2/A,EDN5,EDN5/A,EDS1/A,EDS2,EDS2/A,EDS3 EDS4,EDS5,EDS6,EDS6/A,EDT,EDT/A,EDT1/A,EDT2,EDT3,EDT6,EDT6/A ED6/A,ED8/A,ED9/A,ENT,ENT/A,ENT2,EN6,EN6/A,PKT2,PKT2/A,PKT4 PKT4/A,PKX2,PKX4,PKX4/A,PX/A,PXA2,PXE8,PXE8/A,P1/A,QAB2,QAB2/A QAC2,QAC2/A,QAE2,QAE2/A,QAE6,QAE6/A,QAG,QAG/A,QA2,QA2/A,QAP QAP2,QAP2/A,QA2,QA2/A,QA26,QA26/A,QDW9,QDW9/A,QA,QA/A,QHB3 QHB3/A,QHB5,QHE/A,QHP1,QHP1/A,QHQ4,QHQ4/A,QH2,QKA4,QKA4/A,QL2 QME0,QME0/A,QME8,QME8/A,QMH,QMH/A,QMT2,QMT2/A,QMX2,QNE2,QNE2/A QNE6,QNE9/A,QNR2,QNR2/A,QNR6,QNR6/A,QN18,QP/A,QPE2,QT/A,QTC2 QTC2/A,QWH2,QWH2/A,QX/A,QXB/A,QXB7,QXB7/A,QXC/A,QXC4,QXC4/A,QXC6 QXC6/A,QXC9,QXC9/A,QXE/A,QXE2,QXE4,QXE4/A,QXE6,QXE6/A,QXE8,QXE8/A QXQ4,QXQ4/A,QXU,QXU/A,QX2,Q1/A,SDE,SE/A,SH/A,SHB1,SHB3,SHB3/A SHQ4,SHQ4/A,SHT,SJ/A,SJG,SJG/A,SKE,SKE/A,SKZ,SKZ/A,SME0,SME0/A SME2,SMX2,SMX2/A,STJ/A,STP/A,STQ/A,STR,STR/A,SWX/A,SWX/A,SXB/A SXB7,SXB7/A,SXE/A,SXE8/A,SXE2,SXE4,SXE4/A,SXE8,SXE8/A,SXQ4,SXQ4/A SXU,SXU/A,S1/A,VAD2,VAD2/A,VAH1,VAH2,VAW1,VA2,VA2/A,VC2,VC2/A,VDE VDE2,VDE2/A,VD16,VEB6,VH12,VH12/A,VH22,VH22/A,VMQ,VMX,VSH7,VS2 VS3,VS4,VS5,VS6,VS7,VTE2,VWA,VWA2,VWC,VWC2,VWC2/A,VWE,VWE2,VWE2/A VWS2,VWS2/A,VW12,VW12/A,VX/A,VXB/A,VXB2,VXB7,VXB7/A,VXE/A,VXE8/A VXE2,VXE2/A,VXE4,VXE6,VXE7,VXE7/A,VXE8,VXE8/A,VXG,VXK,VXQ4,VXQ4/A VXU,VXU/A,VXU1,VXU1/A,VX16,VX16/A,VX8,VX8/A EDN,EDS,ED6,ED7,ED8,ED9,EN,ET,ETS,ETX,PX,P1,QA,QAE,QAQ,QA,QH,QHC QHE,QNE,QNE9,QP,QT,QX,QXB,QXC,QXE,QXE8,Q1,SE,SH,SHE,SHEZ,SJ,STJ STP,STQ,SWX,SX,SXB,SXE,SXE8,SXP,S1,VA,VAA,VAAE,VE,VH,VHE,VNG,VNG1 VNG2,VX,VXA,VXB,VXE,VXE8,V1,YJ
			1	1	-	2259155 -----	
			1	-	-	2258974 -----	EDS1,EDT1
			-	-	1		
11	15632-883-630	PIPE COMP., OIL .....	1	-	-	-----	SHT,STR,STR/A
12	16510-ZE3-000	GOVERNOR ASSY. ....	1	1	-	-----	EDE2,EDE2/A,EDK,EDN,EDN2,EDN2/A,EDN5,EDN5/A,EDS,EDS1,EDS1/A,EDS2 EDS2/A,EDS3,EDS4,EDS5,EDS6,EDS6/A,EDT,EDT/A,EDT1,EDT1/A,EDT2,EDT3 EDT6,EDT6/A,ED6,ED6/A,ED7,ED8,ED8/A,ED9,ED9/A,EN,ENT,ENT/A,ENT2 EN6,EN6/A,ET,ETS,ETX,PKT2,PKT2/A,PKT4,PKT4/A,PKX2,PKX4,PKX4/A,PX PX/A,PXA2,PXE8,PXE8/A,P1,P1/A,QA,QAB2,QAB2/A,QAC2,QAC2/A,QAE,QAE2 QAE2/A,QAE6,QAE6/A,QAG,QAG/A,QA2,QA2/A,QAP,QAPE,QAP2,QAP2/A,QAQ QA2,QA2/A,QA26,QA26/A,QDW9,QDW9/A,QA,QA/A,QH,QH/A,QHB3,QHB3/A QHB5,QHC,QHE,QHE/A,QHP1,QHP1/A,QHQ4,QHQ4/A,QH2,QKA4,QKA4/A,QL2 QME0,QME0/A,QME8,QME8/A,QMH,QMH/A,QMT2,QMT2/A,QMX2,QNE,QNE2 QNE2/A,QNE6,QNE9,QNE9/A,QNR2,QNR2/A,QNR6,QNR6/A,QN18,QP,QP/A,QPE2 QT,QT/A,QTC2,QTC2/A,QWH2,QWH2/A,QX,QX/A,QXB,QXB/A,QXB7,QXB7/A,QXC QXC/A,QXC4,QXC4/A,QXC6,QXC6/A,QXC9,QXC9/A,QXE,QXE/A,QXE8,QXE8/A QXE4,QXE4/A,QXE6,QXE6/A,QXE8,QXE8/A,QXQ4,QXQ4/A,QXU,QXU/A,QX2,Q1 Q1/A,SDE,SE,SE/A,SH,SH/A,SHB1,SHB3,SHB3/A,SHE,SHEZ,SHQ4,SHQ4/A SHT,SJ,SJ/A,SJG,SJG/A,SKE,SKE/A,SKZ,SKZ/A,SME0,SME0/A,SME2,SMX2 SMX2/A,STJ,STJ/A,STP,STP/A,STQ,STQ/A,STR,STR/A,SWX,SWX/A,SX,SX/A SXB,SXB/A,SXB7,SXB7/A,SXE,SXE/A,SXE8,SXE8/A,SXE2,SXE4,SXE4/A,SXE8 SXE8/A,SXP,SXQ4,SXQ4/A,SXU,SXU/A,S1,S1/A,VA,VAA,VAAE,VAD2,VAD2/A VAH1,VAH2,VAW1,VA2,VA2/A,VC2,VC2/A,VDE,VDE2,VDE2/A,VD16,VE,VEB6 VH,VHE,VH12,VH12/A,VH22,VH22/A,VMQ,VMX,VNG,VNG1,VNG2,VSH7,VS2,VS3 VS4,VS5,VS6,VS7,VTE2,VWA,VWA2,VWC,VWC2,VWC2/A,VWE,VWE2,VWE2/A VWS2,VWS2/A,VW12,VW12/A,VX,VX/A,VXA,VXB,VXB/A,VXB2,VXB7,VXB7/A VXE,VXE/A,VXE8,VXE8/A,VXE2,VXE2/A,VXE4,VXE6,VXE7,VXE7/A,VXE8 VXE8/A,VXG,VXK,VXQ4,VXQ4/A,VXU,VXU/A,VXU1,VXU1/A,VX16,VX16/A,VX8 VX8/A,V1,YJ
			-	-	1		



E-6

CRANKCASE COVER(1)

G 4

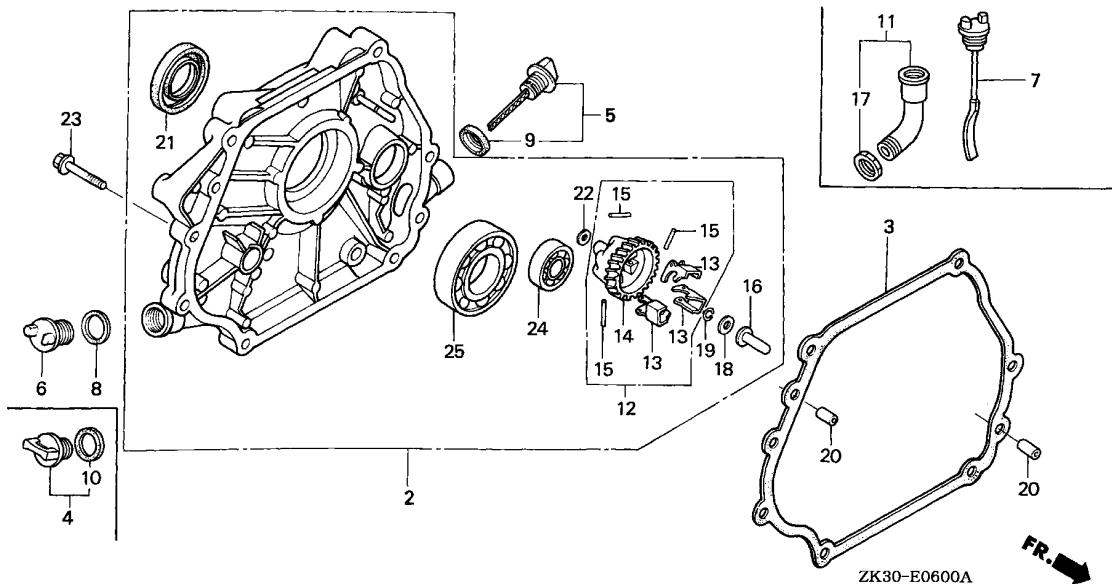

Ref. No.	Part No.	Description	Reqd. QTY			Serial No.	Parts catalogue code
			GX	340K1			
			(1)	(2)	(3)		
13	16511-ZE8-000	WEIGHT, GOVERNOR .....	3	3	-	-----	EDE2,EDE2/A,EDK,EDN,EDN2,EDN2/A,EDN5,EDN5/A,EDS,EDS1,EDS1/A,EDS2,EDS2/A,EDS3,EDS4,EDS5,EDS6,EDS6/A,EDT,EDT/A,EDT1,EDT1/A,EDT2,EDT3,EDT6,EDT6/A,ED6,ED6/A,ED7,ED8,ED8/A,ED9,ED9/A,EN,ENT,ENT/A,ENT2,EN6,EN6/A,ET,ETS,ETX,PKT2,PKT2/A,PKT4,PKT4/A,PKX2,PKX4,PKX4/A,PX,PX/A,PXA2,PXE8,PXE8/A,P1,P1/A,QA,QAB2,QAB2/A,QAC2,QAC2/A,QAE,QAE2,QAE2/A,QAE6,QAE6/A,QAG,QAG/A,QA2,QA2/A,QAP,QAPE,QAP2,QAP2/A,QAQ,QA2,QA2/A,QA26,QA26/A,QDW9,QDW9/A,QE,QE/A,QH,QH/A,QHB3,QHB3/A,QHB5,QHC,QHE,QHE/A,QHP1,QHP1/A,QHQ4,QHQ4/A,QH2,QKA4,QKA4/A,QL2,QME0,QME0/A,QME8,QME8/A,QMH,QMH/A,QMT2,QMT2/A,QMX2,QNE,QNE2,QNE2/A,QNE6,QNE9,QNE9/A,QNR2,QNR2/A,QNR6,QNR6/A,QN18,QP,QP/A,QPE2,QT,QT/A,QTC2,QTC2/A,QWH2,QWH2/A,QX,QX/A,QXB,QXB/A,QXB7,QXB7/A,QXC,QXC/A,QXC4,QXC4/A,QXC6,QXC6/A,QXC9,QXC9/A,QXE,QXE/A,QXEB,QXE2,QXE4,QXE4/A,QXE6,QXE6/A,QXE8,QXE8/A,QXQ4,QXQ4/A,QXU,QXU/A,QX2,Q1,Q1/A,SDE,SE,SE/A,SH,SH/A,SHB1,SHB3,SHB3/A,SHE,SHEZ,SHQ4,SHQ4/A,SHT,SJ,SJ/A,SJ6,SJ6/A,SKE,SKE/A,SKZ,SKZ/A,SME0,SME0/A,SME2,SMX2,SMX2/A,STJ,STJ/A,STP,STP/A,STQ,STQ/A,STR,STR/A,SWX,SWX/A,SX,SX/A,SXB,SXB/A,SXB7,SXB7/A,SXE,SXE/A,SXEB,SXEB/A,SXE2,SXE4,SXE4/A,SXE8,SXE8/A,SXP,SXQ4,SXQ4/A,SXU,SXU/A,S1,S1/A,VA,VAA,VAAE,VAD2,VAD2/A,VAH1,VAH2,VAW1,VA2,VA2/A,VC2,VC2/A,VDE,VDE2,VDE2/A,VD16,VE,VEB6,VH,VHE,VH12,VH12/A,VH22,VH22/A,VMQ,VMX,VNG,VNG1,VNG2,VSH7,VS2,VS3,VS4,VS5,VS6,VS7,VTE2,VWA,VWA2,VWC,VWC2,VWC2/A,VWE,VWE2,VWE2/A,VWS2,VWS2/A,VW12,VW12/A,VX,VX/A,VXA,VXB,VXB/A,VXB2,VXB7,VXB7/A,VXE,VXE/A,VXEB,VXEB/A,VXE2,VXE2/A,VXE4,VXE6,VXE7,VXE7/A,VXE8,VXE8/A,VXG,VXK,VXQ4,VXQ4/A,VXU,VXU/A,VXU1,VXU1/A,VX16,VX16/A,VX8,VX8/A,V1,YJ
			-	-	3		

Ref. No.	Part No.	Description	Reqd. QTY			Serial No.	Parts catalogue code
			(1)	(2)	(3)		
14	16512-ZE3-000	HOLDER, GOVERNOR WEIGHT .....	1	1	-	-----	EDE2,EDE2/A,EDK,EDN,EDN2,EDN2/A,EDN5,EDN5/A,EDS,EDS1,EDS1/A,EDS2,EDS2/A,EDS3,EDS4,EDS5,EDS6,EDS6/A,EDT,EDT/A,EDT1,EDT1/A,EDT2,EDT3,EDT6,EDT6/A,ED6,ED6/A,ED7,ED8,ED8/A,ED9,ED9/A,EN,ENT,ENT/A,ENT2,EN6,EN6/A,ET,ETS,ETX,PKT2,PKT2/A,PKT4,PKT4/A,PKX2,PKX4,PKX4/A,PX,PX/A,PXA2,PXE8,PXE8/A,P1,P1/A,QA,QAB2,QAB2/A,QAC2,QAC2/A,QAE,QAE2,QAE2/A,QAE6,QAE6/A,QAG,QAG/A,QAQ2,QAQ2/A,QAP,QAPE,QAP2,QAP2/A,QAQ,QA2,QA2/A,QA26,QA26/A,QDW9,QDW9/A,QE,QE/A,QH,QH/A,QHB3,QHB3/A,QHB5,QHC,QHE,QHE/A,QHP1,QHP1/A,QHQ4,QHQ4/A,QH2,QKA4,QKA4/A,QL2,QMEO,QMEO/A,QME8,QME8/A,QMH,QMH/A,QMT2,QMT2/A,QMX2,QNE,QNE2,QNE2/A,QNE6,QNE9,QNE9/A,QNR2,QNR2/A,QNR6,QNR6/A,QN18,QP,QP/A,QPE2,QT,QT/A,QTC2,QTC2/A,QWH2,QWH2/A,QX,QX/A,QXB,QXB/A,QXB7,QXB7/A,QXC,QXC/A,QXC4,QXC4/A,QXC6,QXC6/A,QXC9,QXC9/A,QXE,QXE/A,QXEB,QXE2,QXE4,QXE4/A,QXE6,QXE6/A,QXE8,QXE8/A,QXQ4,QXQ4/A,QXU,QXU/A,QX2,Q1,Q1/A,SDE,SE,SE/A,SH,SH/A,SHB1,SHB3,SHB3/A,SHE,SHEZ,SHQ4,SHQ4/A,SHT,SJ,SJ/A,SJG,SJG/A,SKE,SKE/A,SKZ,SKZ/A,SME0,SME0/A,SME2,SMX2,SMX2/A,STJ,STJ/A,STP,STP/A,STQ,STQ/A,STR,STR/A,SWX,SWX/A,SX,SX/A,SXB,SXB/A,SXB7,SXB7/A,SXE,SXE/A,SXEB,SXEB/A,SXE2,SXE4,SXE4/A,SXE8,SXE8/A,SXP,SXQ4,SXQ4/A,SXU,SXU/A,S1,S1/A,VA,VAA,VAE,VAD2,VAD2/A,VAH1,VAH2,VAW1,VA2,VA2/A,VC2,VC2/A,VDE,VDE2,VDE2/A,VD16,VE,VEB6,VH,VHE,VH12,VH12/A,VH22,VH22/A,VMQ,VMX,VNG,VNG1,VNG2,VSH7,VS2,VS3,VS4,VS5,VS6,VS7,VTE2,VWA,VWA2,VWC,VWC2,VWC2/A,VWE,VWE2,VWE2/A,VWS2,VWS2/A,VW12,VW12/A,VX,VX/A,VXA,VXB,VXB/A,VXB2,VXB7,VXB7/A,VXE,VXE/A,VXEB,VXEB/A,VXE2,VXE2/A,VXE4,VXE6,VXE7,VXE7/A,VXE8,VXE8/A,VXG,VXK,VXQ4,VXQ4/A,VXU,VXU/A,VXU1,VXU1/A,VX16,VX16/A,VX8,VX8/A,V1,YJ
15	16513-ZE2-000	PIN, GOVERNOR WEIGHT .....	3	3	-	-----	EDE2,EDE2/A,EDK,EDN,EDN2,EDN2/A,EDN5,EDN5/A,EDS,EDS1,EDS1/A,EDS2,EDS2/A,EDS3,EDS4,EDS5,EDS6,EDS6/A,EDT,EDT/A,EDT1,EDT1/A,EDT2,EDT3,EDT6,EDT6/A,ED6,ED6/A,ED7,ED8,ED8/A,ED9,ED9/A,EN,ENT,ENT/A,ENT2,EN6,EN6/A,ET,ETS,ETX,PKT2,PKT2/A,PKT4,PKT4/A,PKX2,PKX4,PKX4/A,PX,PX/A,PXA2,PXE8,PXE8/A,P1,P1/A,QA,QAB2,QAB2/A,QAC2,QAC2/A,QAE,QAE2,QAE2/A,QAE6,QAE6/A,QAG,QAG/A,QAQ2,QAQ2/A,QAP,QAPE,QAP2,QAP2/A,QAQ,QA2,QA2/A,QA26,QA26/A,QDW9,QDW9/A,QE,QE/A,QH,QH/A,QHB3,QHB3/A,QHB5,QHC,QHE,QHE/A,QHP1,QHP1/A,QHQ4,QHQ4/A,QH2,QKA4,QKA4/A,QL2,QMEO,QMEO/A,QME8,QME8/A,QMH,QMH/A,QMT2,QMT2/A,QMX2,QNE,QNE2,QNE2/A,QNE6,QNE9,QNE9/A,QNR2,QNR2/A,QNR6,QNR6/A,QN18,QP,QP/A,QPE2,QT,QT/A,QTC2,QTC2/A,QWH2,QWH2/A,QX,QX/A,QXB,QXB/A,QXB7,QXB7/A,QXC,QXC/A,QXC4,QXC4/A,QXC6,QXC6/A,QXC9,QXC9/A,QXE,QXE/A,QXEB,QXE2,QXE4,QXE4/A,QXE6,QXE6/A,QXE8,QXE8/A,QXQ4,QXQ4/A,QXU,QXU/A,QX2,Q1,Q1/A,SDE,SE,SE/A,SH,SH/A,SHB1,SHB3,SHB3/A,SHE,SHEZ,SHQ4,SHQ4/A,SHT,SJ,SJ/A,SJG,SJG/A,SKE,SKE/A,SKZ,SKZ/A,SME0,SME0/A,SME2,SMX2,SMX2/A,STJ,STJ/A,STP,STP/A,STQ,STQ/A,STR,STR/A,SWX,SWX/A,SX,SX/A,SXB,SXB/A,SXB7,SXB7/A,SXE,SXE/A,SXEB,SXEB/A,SXE2,SXE4,SXE4/A,SXE8,SXE8/A,SXP,SXQ4,SXQ4/A,SXU,SXU/A,S1,S1/A,VA,VAA,VAE,VAD2,VAD2/A,VAH1,VAH2,VAW1,VA2,VA2/A,VC2,VC2/A,VDE,VDE2,VDE2/A,VD16,VE,VEB6,VH,VHE,VH12,VH12/A,VH22,VH22/A,VMQ,VMX,VNG,VNG1,VNG2,VSH7,VS2,VS3,VS4,VS5,VS6,VS7,VTE2,VWA,VWA2,VWC,VWC2,VWC2/A,VWE,VWE2,VWE2/A,VWS2,VWS2/A,VW12,VW12/A,VX,VX/A,VXA,VXB,VXB/A,VXB2,VXB7,VXB7/A,VXE,VXE/A,VXEB,VXEB/A,VXE2,VXE2/A,VXE4,VXE6,VXE7,VXE7/A,VXE8,VXE8/A,VXG,VXK,VXQ4,VXQ4/A,VXU,VXU/A,VXU1,VXU1/A,VX16,VX16/A,VX8,VX8/A,V1,YJ
			-	-	1		
			-	-	3		



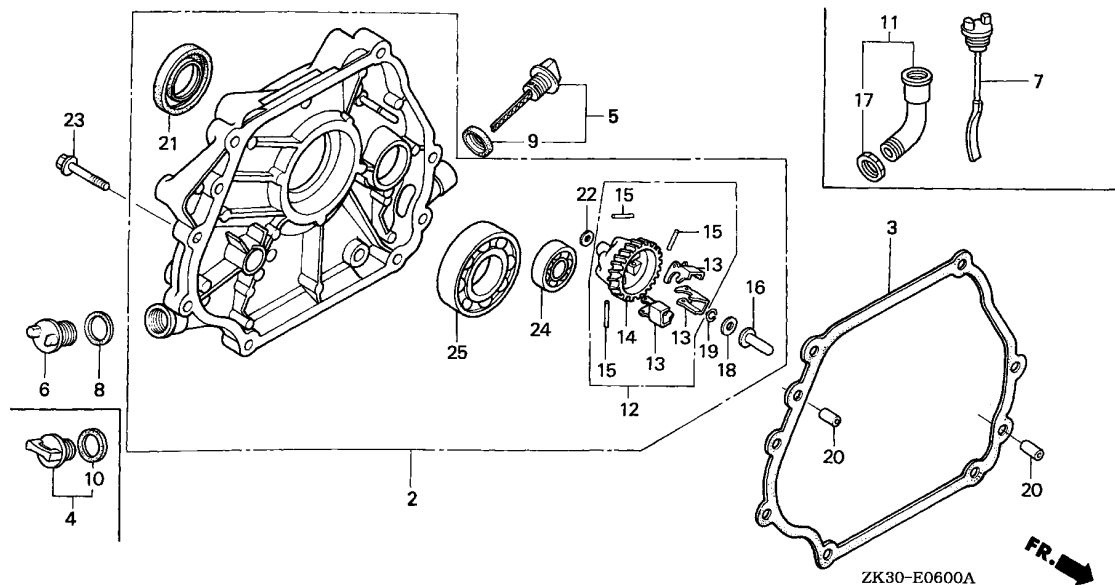

Ref. No.	Part No.	Description	Reqd. QTY			Serial No.	Parts catalogue code
			GX	340K1			
			(1)	(2)	(3)		
16	16531-ZE2-000	SLIDER, GOVERNOR .....	1	-	-	3460754	EDE2,EDN2,EDN5,EDS1,EDS2,EDS6,EDT,EDT1,EDT6,ED6,ED8,ED9,ENT,EN6 PKT2,PKT4,PKX4,PX,PXE8,QAB2,QAC2,QAE2,QAE6,QAG,QA2,QAP2,QA2,QA26 QDW9,QE,QH,QHB3,QHE,QHP1,QHQ4,QKA4,QME0,QME8,QMH,QMT2,QNE2,QNE9 QNR2,QNR6,QP,QT,QTC2,QWH2,QX,QXB,QXC,QXC4,QXC6,QXC9,QXE,QXE4,QXE6 QXE8,QXQ4,QXU,SE,SH,SHB3,SHQ4,SJ,SJG,SKE,SKZ,SMEO,SMX2,STJ,STP STQ,STR,SWX,SX,SXB,SXE,SXEB,SXE4,SXE8,SXQ4,SXU,VAD2,VA2,VC2,VDE2 VH12,VH22,VWC2,VWE2,VWS2,VW12,VX,VXB,VXE,VXEB,VXE2,VXE8,VXQ4,VXU VXU1,VX16,VX8



Ref. No.	Part No.	Description	Reqd. QTY			Serial No.	Parts catalogue code
			(1)	(2)	(3)		
16)	16531-Z0A-000	SLIDER, GOVERNOR .....	1	1	-	-	EDE2/A, EDK, EDN, EDN2/A, EDN5/A, EDS, EDS1/A, EDS2/A, EDS3, EDS4, EDS5, EDS6/A, EDT/A, EDT1/A, EDT2, EDT3, EDT6/A, ED6/A, ED7, ED8/A, ED9/A, ENT/A, ENT2, EN6/A, ET, ETS, ETX, PKT2/A, PKT4/A, PKX2, PKX4/A, PX/A, PXA2, PXE8/A, P1, P1/A, QA, QAB2/A, QAC2/A, QAE, QAE2/A, QAE6/A, QAG/A, QAH2/A, QAP, QAPE, QAP2/A, QAQ, QA2/A, QA26/A, QDW9/A, QE/A, QH/A, QHB3/A, QHB5, QHC, QHE/A, QHP1/A, QHQ4/A, QH2, QKA4/A, QL2, QMEO/A, QME8/A, QMH/A, QMT2/A, QMX2, QNE, QNE2/A, QNE6, QNE9/A, QNR2/A, QNR6/A, QN18, QP/A, QPE2, QT/A, QTC2/A, QWH2/A, QX/A, QXB/A, QXB7, QXB7/A, QXC/A, QXC4/A, QXC6/A, QXC9/A, QXE/A, QXEB, QXE2, QXE4/A, QXE6/A, QXE8/A, QXQ4/A, QXU/A, QX2, Q1, Q1/A, SDE, SE/A, SH/A, SHB1, SHB3/A, SHE, SHEZ, SHQ4/A, SHT, SJ/A, SJG/A, SKE/A, SKZ/A, SMEO/A, SME2, SMX2/A, STJ/A, STP/A, STQ/A, STR/A, SWX/A, SX/A, SXB/A, SXB7, SXB7/A, SXE/A, SXEB/A, SXE2, SXE4/A, SXE8/A, SXP, SXQ4/A, SXU/A, S1, S1/A, VA, VAA, VAAE, VAD2/A, VAH1, VAH2, VAW1, VA2/A, VC2/A, VDE, VDE2/A, VD16, VE, VEB6, VH, VHE, VH12/A, VH22/A, VMQ, VMX, VNG, VNG1, VNG2, VSH7, VS2, VS3, VS4, VS5, VS6, VS7, VTE2, VVA, VVA2, VWC, VWC2/A, VWE, VWE2/A, VWS2/A, VW12/A, VX/A, VXA, VXB/A, VXB2, VXB7, VXB7/A, VXE/A, VXEB/A, VXE2/A, VXE4, VXE6, VXE7, VXE7/A, VXE8/A, VXG, VXK, VXQ4/A, VXU/A, VXU1/A, VX16/A, VX8/A, V1, YJ
			1	-	-	3460755	EDE2, EDN2, EDN5, EDS1, EDS2, EDS6, EDT, EDT1, EDT6, ED6, ED8, ED9, ENT, EN6, PKT2, PKT4, PKX4, PX, PXE8, QAB2, QAC2, QAE2, QAE6, QAG, QAH2, QAP2, QK26, QDW9, QE, QH, QHB3, QHE, QHP1, QHQ4, QKA4, QMEO, QME8, QMH, QMT2, QNE2, QNE9, QNR2, QNR6, QP, QT, QTC2, QWH2, QX, QXB, QXC, QXC4, QXC6, QXC9, QXE, QXE4, QXE6, QXE8, QXQ4, QXU, SE, SH, SHB3, SHQ4, SJ, SJG, SKE, SKZ, SMEO, SMX2, STJ, STP, STQ, STR, SWX, SX, SXB, SXE, SXEB, SXE4, SXE8, SXQ4, SXU, VAD2, VA2, VC2, VDE2, VH12, VH22, VWC2, VWE2, VWS2, VW12, VX, VXB, VXE, VXEB, VXE2, VXE8, VXQ4, VXU, VXU1, VX16, VX8
			-	-	1		SHT, STR, STR/A
17	90011-883-630	NUT, OIL FILLER .....	1	-	-		
18	90473-147-000	WASHER, 6X16 .....	1	1	-		EDE2, EDE2/A, EDN, EDN2, EDN2/A, EDN5, EDN5/A, EDS, EDS1, EDS1/A, EDS2, EDS2/A, EDS6, EDS6/A, EDT, EDT/A, EDT1, EDT1/A, EDT6, EDT6/A, ED6, ED6/A, ED7, ED8, ED8/A, ED9, ED9/A, EN, ENT, ENT/A, EN6, EN6/A, ET, ETS, ETX, LT, LT/A, PKT2, PKT2/A, PKT4, PKT4/A, PKX4, PKX4/A, PX, PX/A, PXE8, PXE8/A, P1, P1/A, QA, QAB2, QAB2/A, QAC2, QAC2/A, QAE, QAE2, QAE2/A, QAE6, QAE6/A, QAG, QAG/A, QAH2, QAH2/A, QAP, QAPE, QAP2, QAP2/A, QAQ, QA2, QA2/A, QA26, QA26/A, QDW9, QDW9/A, QE, QE/A, QH, QH/A, QHB3, QHB3/A, QHC, QHE, QHE/A, QHP1, QHP1/A, QHQ4, QHQ4/A, QKA4, QKA4/A, QMEO, QMEO/A, QME8, QME8/A, QMH, QMH/A, QMT2, QMT2/A, QNE, QNE2, QNE2/A, QNE9, QNE9/A, QNR2, QNR2/A, QNR6, QNR6/A, QP, QP/A, QT, QT/A, QTC2, QTC2/A, QWH2, QWH2/A, QX, QX/A, QXB, QXB/A, QXB7, QXC, QXC/A, QXC4, QXC4/A, QXC6, QXC6/A, QXC9, QXC9/A, QXE, QXE/A, QXEB, QXE4, QXE4/A, QXE6, QXE6/A, QXE8, QXE8/A, QXQ4, QXQ4/A, QXU, QXU/A, Q1, Q1/A, SE, SE/A, SH, SH/A, SHB3, SHB3/A, SHE, SHEZ, SHQ4, SHQ4/A, SJ, SJ/A, SJG, SJG/A, SKE, SKE/A, SKZ, SKZ/A, SMEO, SMEO/A, SMX2, SMX2/A, STJ, STJ/A, STP, STP/A, STQ, STQ/A, STR, STR/A, SWX, SWX/A, SX, SX/A, SXB, SXB/A, SXB7, SXE, SXE/A, SXEB, SXEB/A, SXE4, SXE4/A, SXE8, SXE8/A, SXP, SXQ4, SXQ4/A, SXU, SXU/A, S1, S1/A, VA, VAA, VAAE, VAD2, VAD2/A, VAH1, VAH2, VA2, VA2/A, VC2, VC2/A, VDE2, VDE2/A, VE, VH, VHE, VH12, VH12/A, VH22, VH22/A, VNG, VNG1, VNG2, VVA, VWC2, VWC2/A, VWE2, VWE2/A, VWS2, VWS2/A, VW12, VW12/A, VX, VX/A, VXA, VXB, VXB/A, VXB7, VXE, VXE/A, VXEB, VXEB/A, VXE2, VXE2/A, VXE7, VXE8, VXE8/A, VXQ4, VXQ4/A, VXU, VXU/A, VXU1, VXU1/A, VX16, VX16/A, VX8, VX8/A, V1, YJ



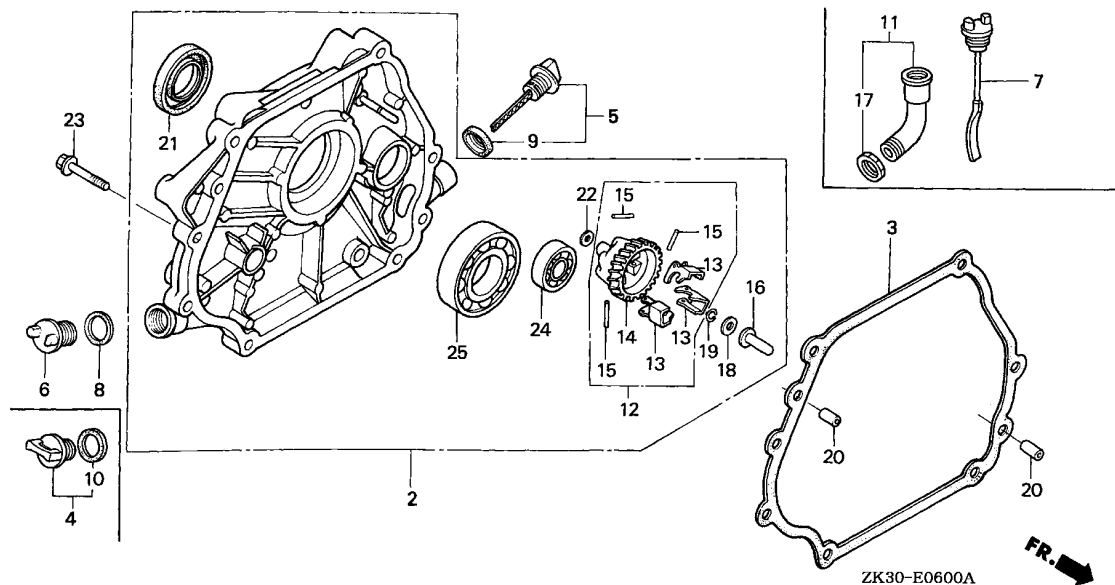

Ref. No.	Part No.	Description	Reqd. QTY			Serial No.	Parts catalogue code
			GX	340K1			
			(1)	(2)	(3)		
19	90602-ZE1-000	CLIP, GOVERNOR HOLDER .....	1	1	-	-----	EDE2,EDE2/A,EDK,EDN,EDN2,EDN2/A,EDN5,EDN5/A,EDS,EDS1,EDS1/A,EDS2,EDS2/A,EDS3,EDS4,EDS5,EDS6,EDS6/A,EDT,EDT/A,EDT1,EDT1/A,EDT2,EDT3,EDT6,EDT6/A,ED6,ED6/A,ED7,ED8,ED8/A,ED9,ED9/A,EN,ENT,ENT/A,ENT2,EN6,EN6/A,ET,ETS,ETX,PKT2,PKT2/A,PKT4,PKT4/A,PKX2,PKX4,PKX4/A,PX,PX/A,PXA2,PXE8,PXE8/A,P1,P1/A,QA,QAB2,QAB2/A,QAC2,QAC2/A,QAE,QAE2,QAE2/A,QAE6,QAE6/A,QAG,QAG/A,QA2,QA2/A,QAP,QAPE,QAP2,QAP2/A,QAQ,QA2,QA2/A,QA26,QA26/A,QDW9,QDW9/A,QE,QE/A,QH,QH/A,QHB3,QHB3/A,QHB5,QHC,QHE,QHE/A,QHP1,QHP1/A,QHQ4,QHQ4/A,QH2,QKA4,QKA4/A,QL2,QME0,QME0/A,QME8,QME8/A,QMH,QMH/A,QMT2,QMT2/A,QMX2,QNE,QNE2,QNE2/A,QNE6,QNE9,QNE9/A,QNR2,QNR2/A,QNR6,QNR6/A,QN18,QP,QP/A,QPE2,QT,QT/A,QTC2,QTC2/A,QWH2,QWH2/A,QX,QX/A,QXB,QXB/A,QXB7,QXB7/A,QXC,QXC/A,QXC4,QXC4/A,QXC6,QXC6/A,QXC9,QXC9/A,QXE,QXE/A,QXEB,QXE2,QXE4,QXE4/A,QXE6,QXE6/A,QXE8,QXE8/A,QXQ4,QXQ4/A,QXU,QXU/A,QX2,Q1,Q1/A,SDE,SE,SE/A,SH,SH/A,SHB1,SHB3,SHB3/A,SHE,SHEZ,SHQ4,SHQ4/A,SHT,SJ,SJ/A,SJ6,SJ6/A,SKE,SKE/A,SKZ,SKZ/A,SME0,SME0/A,SME2,SMX2,SMX2/A,STJ,STJ/A,STP,STP/A,STQ,STQ/A,STR,STR/A,SWX,SWX/A,SX,SX/A,SXB,SXB/A,SXB7,SXB7/A,SXE,SXE/A,SXEB,SXEB/A,SXE2,SXE4,SXE4/A,SXE8,SXE8/A,SXP,SXQ4,SXQ4/A,SXU,SXU/A,S1,S1/A,VA,VAA,VAAE,VAD2,VAD2/A,VAH1,VAH2,VAW1,VA2,VA2/A,VC2,VC2/A,VDE,VDE2,VDE2/A,VD16,VE,VEB6,VH,VHE,VH12,VH12/A,VH22,VH22/A,VMQ,VMX,VNG,VNG1,VNG2,VSH7,VS2,VS3,VS4,VS5,VS6,VS7,VTE2,VWA,VWA2,VWC,VWC2,VWC2/A,VWE,VWE2,VWE2/A,VWS2,VWS2/A,VW12,VW12/A,VX,VX/A,VXA,VXB,VXB/A,VXB2,VXB7,VXB7/A,VXE,VXE/A,VXEB,VXEB/A,VXE2,VXE2/A,VXE4,VXE6,VXE7,VXE7/A,VXE8,VXE8/A,VXG,VXK,VXQ4,VXQ4/A,VXU,VXU/A,VXU1,VXU1/A,VX16,VX16/A,VX8,VX8/A,V1,YJ
			-	-	1		

Ref. No.	Part No.	Description	Reqd. QTY			Serial No.	Parts catalogue code
			GX 340K1 (1)	(2)	(3)		
20	90701-HC4-000	DOWEL PIN, 8X12 .....	2	2	-	-----	EDE2,EDE2/A,EDK,EDN,EDN2,EDN2/A,EDN5,EDN5/A,EDS,EDS1,EDS1/A,EDS2,EDS2/A,EDS3,EDS4,EDS5,EDS6,EDS6/A,EDT,EDT/A,EDT1,EDT1/A,EDT2,EDT3,EDT6,EDT6/A,ED6,ED6/A,ED7,ED8,ED8/A,ED9,ED9/A,EN,ENT,ENT/A,ENT2,EN6,EN6/A,ET,ETS,ETX,PKT2,PKT2/A,PKT4,PKT4/A,PKX2,PKX4,PKX4/A,PX,PX/A,PXA2,PXE8,PXE8/A,P1,P1/A,QA,QAB2,QAB2/A,QAC2,QAC2/A,QAE,QAE2,QAE2/A,QAE6,QAE6/A,QAG,QAG/A,QAQ2,QAQ2/A,QAP,QAPE,QAP2,QAP2/A,QAQ,QA2,QA2/A,QA26,QA26/A,QDW9,QDW9/A,QE,QE/A,QH,QH/A,QHB3,QHB3/A,QHB5,QHC,QHE,QHE/A,QHP1,QHP1/A,QHQ4,QHQ4/A,QH2,QKA4,QKA4/A,QL2,QMEO,QMEO/A,QME8,QME8/A,QMH,QMH/A,QMT2,QMT2/A,QMX2,QNE,QNE2,QNE2/A,QNE6,QNE9,QNE9/A,QNR2,QNR2/A,QNR6,QNR6/A,QN18,QP,QP/A,QPE2,QT,QT/A,QTC2,QTC2/A,QWH2,QWH2/A,QX,QX/A,QXB,QXB/A,QXB7,QXB7/A,QXC,QXC/A,QXC4,QXC4/A,QXC6,QXC6/A,QXC9,QXC9/A,QXE,QXE/A,QXEB,QXE2,QXE4,QXE4/A,QXE6,QXE6/A,QXE8,QXE8/A,QXQ4,QXQ4/A,QXU,QXU/A,QX2,Q1,Q1/A,SDE,SE,SE/A,SH,SH/A,SHB1,SHB3,SHB3/A,SHE,SHEZ,SHQ4,SHQ4/A,SHT,SJ,SJ/A,SJG,SJG/A,SKE,SKE/A,SKZ,SKZ/A,SME0,SME0/A,SME2,SMX2,SMX2/A,STJ,STJ/A,STP,STP/A,STQ,STQ/A,STR,STR/A,SWX,SWX/A,SX,SX/A,SXB,SXB/A,SXB7,SXB7/A,SXE,SXE/A,SXEB,SXEB/A,SXE2,SXE4,SXE4/A,SXE8,SXE8/A,SXP,SXQ4,SXQ4/A,SXU,SXU/A,S1,S1/A,VA,VAA,VAE,VAE2,VAE2/A,VAH1,VAH2,VAW1,VA2,VA2/A,VC2,VC2/A,VDE,VDE2,VDE2/A,VD16,VE,VEB6,VH,VHE,VH12,VH12/A,VH22,VH22/A,VMQ,VMX,VNG,VNG1,VNG2,VSH7,VS2,VS3,VS4,VS5,VS6,VS7,VTE2,VWA,VWA2,VWC,VWC2,VWC2/A,VWE,VWE2,VWE2/A,VWS2,VWS2/A,VW12,VW12/A,VX,VX/A,VXA,VXB,VXB/A,VXB2,VXB7,VXB7/A,VXE,VXE/A,VXEB,VXEB/A,VXE2,VXE2/A,VXE4,VXE6,VXE7,VXE7/A,VXE8,VXE8/A,VXG,VXK,VXQ4,VXQ4/A,VXU,VXU/A,VXU1,VXU1/A,VX16,VX16/A,VX8,VX8/A,V1,YJ
			-	-	2		
21	91201-ZE3-004	OIL SEAL, 35X52X8 .....	1	1	-	-----	EDE2,EDE2/A,EDK,EDN,EDN2,EDN2/A,EDN5,EDN5/A,EDS,EDS1,EDS1/A,EDS2,EDS2/A,EDS3,EDS4,EDS5,EDS6,EDS6/A,EDT,EDT/A,EDT1,EDT1/A,EDT2,EDT3,EDT6,EDT6/A,ED6,ED6/A,ED7,ED8,ED8/A,ED9,ED9/A,EN,ENT,ENT/A,ENT2,EN6,EN6/A,ET,ETS,ETX,PKT2,PKT2/A,PKT4,PKT4/A,PKX2,PKX4,PKX4/A,PX,PX/A,PXA2,PXE8,PXE8/A,P1,P1/A,QA,QAB2,QAB2/A,QAC2,QAC2/A,QAE,QAE2,QAE2/A,QAE6,QAE6/A,QAG,QAG/A,QAQ2,QAQ2/A,QAP,QAPE,QAP2,QAP2/A,QAQ,QA2,QA2/A,QA26,QA26/A,QDW9,QDW9/A,QE,QE/A,QH,QH/A,QHB3,QHB3/A,QHB5,QHC,QHE,QHE/A,QHP1,QHP1/A,QHQ4,QHQ4/A,QH2,QKA4,QKA4/A,QL2,QMEO,QMEO/A,QME8,QME8/A,QMH,QMH/A,QMT2,QMT2/A,QMX2,QNE,QNE2,QNE2/A,QNE6,QNE9,QNE9/A,QNR2,QNR2/A,QNR6,QNR6/A,QN18,QP,QP/A,QPE2,QT,QT/A,QTC2,QTC2/A,QWH2,QWH2/A,QX,QX/A,QXB,QXB/A,QXB7,QXB7/A,QXC,QXC/A,QXC4,QXC4/A,QXC6,QXC6/A,QXC9,QXC9/A,QXE,QXE/A,QXEB,QXE2,QXE4,QXE4/A,QXE6,QXE6/A,QXE8,QXE8/A,QXQ4,QXQ4/A,QXU,QXU/A,QX2,Q1,Q1/A,SDE,SE,SE/A,SH,SH/A,SHB1,SHB3,SHB3/A,SHE,SHEZ,SHQ4,SHQ4/A,SHT,SJ,SJ/A,SJG,SJG/A,SKE,SKE/A,SKZ,SKZ/A,SME0,SME0/A,SME2,SMX2,SMX2/A,STJ,STJ/A,STP,STP/A,STQ,STQ/A,STR,STR/A,SWX,SWX/A,SX,SX/A,SXB,SXB/A,SXB7,SXB7/A,SXE,SXE/A,SXEB,SXEB/A,SXE2,SXE4,SXE4/A,SXE8,SXE8/A,SXP,SXQ4,SXQ4/A,SXU,SXU/A,S1,S1/A,VA,VAA,VAE,VAE2,VAE2/A,VAH1,VAH2,VAW1,VA2,VA2/A,VC2,VC2/A,VDE,VDE2,VDE2/A,VD16,VE,VEB6,VH,VHE,VH12,VH12/A,VH22,VH22/A,VMQ,VMX,VNG,VNG1,VNG2,VSH7,VS2,VS3,VS4,VS5,VS6,VS7,VTE2,VWA,VWA2,VWC,VWC2,VWC2/A,VWE,VWE2,VWE2/A,VWS2,VWS2/A,VW12,VW12/A,VX,VX/A,VXA,VXB,VXB/A,VXB2,VXB7,VXB7/A,VXE,VXE/A,VXEB,VXEB/A,VXE2,VXE2/A,VXE4,VXE6,VXE7,VXE7/A,VXE8,VXE8/A,VXG,VXK,VXQ4,VXQ4/A,VXU,VXU/A,VXU1,VXU1/A,VX16,VX16/A,VX8,VX8/A,V1,YJ
			-	-	1		



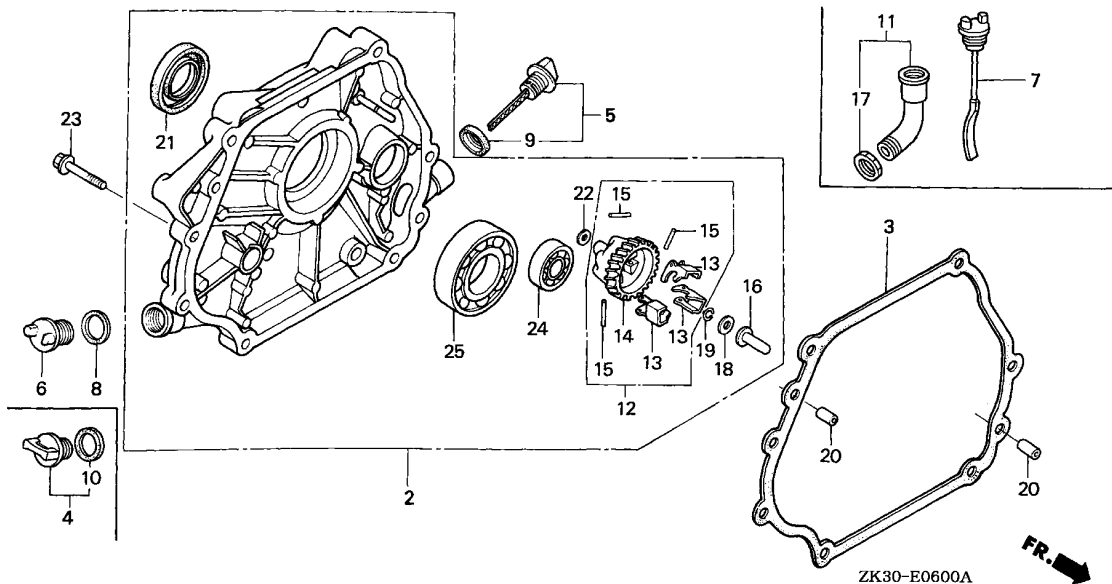

Ref. No.	Part No.	Description	Reqd. QTY			Serial No.	Parts catalogue code
			GX	340K1	(3)		
22	94101-06800	WASHER, PLAIN, 6MM .....	(1)	(2)	(3)	-----	EDE2,EDE2/A,EDK,EDN,EDN2,EDN2/A,EDN5,EDN5/A,EDS,EDS1,EDS1/A,EDS2,EDS2/A,EDS3,EDS4,EDS5,EDS6,EDS6/A,EDT,EDT/A,EDT1,EDT1/A,EDT2,EDT3,EDT6,EDT6/A,ED6,ED6/A,ED7,ED8,ED8/A,ED9,ED9/A,EN,ENT,ENT/A,ENT2,EN6,EN6/A,ET,ETS,ETX,PKT2,PKT2/A,PKT4,PKT4/A,PKX2,PKX4,PKX4/A,PX,PX/A,PXA2,PXE8,PXE8/A,P1,P1/A,QA,QAB2,QAB2/A,QAC2,QAC2/A,QAE,QAE2,QAE2/A,QAE6,QAE6/A,QAG,QAG/A,QA2,QA2/A,QAP,QAPE,QAP2,QAP2/A,QAQ,QA2,QA2/A,QA26,QA26/A,QDW9,QDW9/A,QE,QE/A,QH,QH/A,QHB3,QHB3/A,QHB5,QHC,QHE,QHE/A,QHP1,QHP1/A,QHQ4,QHQ4/A,QH2,QKA4,QKA4/A,QL2,QME0,QME0/A,QME8,QME8/A,QMH,QMH/A,QMT2,QMT2/A,QMX2,QNE,QNE2,QNE2/A,QNE6,QNE9,QNE9/A,QNR2,QNR2/A,QNR6,QNR6/A,QN18,QP,QP/A,QPE2,QT,QT/A,QTC2,QTC2/A,QWH2,QWH2/A,QX,QX/A,QXB,QXB/A,QXB7,QXB7/A,QXC,QXC/A,QXC4,QXC4/A,QXC6,QXC6/A,QXC9,QXC9/A,QXE,QXE/A,QXEB,QXE2,QXE4,QXE4/A,QXE6,QXE6/A,QXE8,QXE8/A,QXQ4,QXQ4/A,QXU,QXU/A,QX2,Q1,Q1/A,SDE,SE,SE/A,SH,SH/A,SHB1,SHB3,SHB3/A,SHE,SHEZ,SHQ4,SHQ4/A,SHT,SJ,SJ/A,SJ6,SJ6/A,SKE,SKE/A,SKZ,SKZ/A,SME0,SME0/A,SME2,SMX2,SMX2/A,STJ,STJ/A,STP,STP/A,STQ,STQ/A,STR,STR/A,SWX,SWX/A,SX,SX/A,SXB,SXB/A,SXB7,SXB7/A,SXE,SXE/A,SXEB,SXEB/A,SXE2,SXE4,SXE4/A,SXE8,SXE8/A,SXP,SXQ4,SXQ4/A,SXU,SXU/A,S1,S1/A,VA,VAA,VAEA,VAD2,VAD2/A,VAH1,VAH2,VAW1,VA2,VA2/A,VC2,VC2/A,VDE,VDE2,VDE2/A,VD16,VE,VEB6,VH,VHE,VH12,VH12/A,VH22,VH22/A,VMQ,VMX,VNG,VNG1,VNG2,VSH7,VS2,VS3,VS4,VS5,VS6,VS7,VTE2,VWA,VWA2,VWC,VWC2,VWC2/A,VWE,VWE2,VWE2/A,VWS2,VWS2/A,VW12,VW12/A,VX,VX/A,VXA,VXB,VXB/A,VXB2,VXB7,VXB7/A,VXE,VXE/A,VXEB,VXEB/A,VXE2,VXE2/A,VXE4,VXE6,VXE7,VXE7/A,VXE8,VXE8/A,VXG,VXK,VXQ4,VXQ4/A,VXU,VXU/A,VXU1,VXU1/A,VX16,VX16/A,VX8,VX8/A,V1,YJ
			-	-	1		

Ref. No.	Part No.	Description	Reqd. QTY			Serial No.	Parts catalogue code
			GX 340K1 (1)	(2)	(3)		
23	95701-08040-00	BOLT, FLANGE, 8X40 .....	7	7	-	-----	EDE2,EDE2/A,EDK,EDN,EDN2,EDN2/A,EDN5,EDN5/A,EDS,EDS1,EDS1/A,EDS2,EDS2/A,EDS3,EDS4,EDS5,EDS6,EDS6/A,EDT,EDT/A,EDT1,EDT1/A,EDT2,EDT3,EDT6,EDT6/A,ED6,ED6/A,ED7,ED8,ED8/A,ED9,ED9/A,EN,ENT,ENT/A,ENT2,EN6,EN6/A,ET,ETS,ETX,PKT2,PKT2/A,PKT4,PKT4/A,PKX2,PKX4,PKX4/A,PX,PX/A,PXA2,PXE8,PXE8/A,P1,P1/A,QA,QAB2,QAB2/A,QAC2,QAC2/A,QAE,QAE2,QAE2/A,QAE6,QAE6/A,QAG,QAG/A,QAQ2,QAQ2/A,QAP,QAPE,QAP2,QAP2/A,QAQ,QA2,QA2/A,QA26,QA26/A,QDW9,QDW9/A,QE,QE/A,QH,QH/A,QHB3,QHB3/A,QHB5,QHC,QHE,QHE/A,QHP1,QHP1/A,QHQ4,QHQ4/A,QH2,QKA4,QKA4/A,QL2,QMEO,QMEO/A,QME8,QME8/A,QMH,QMH/A,QMT2,QMT2/A,QMX2,QNE,QNE2,QNE2/A,QNE6,QNE9,QNE9/A,QNR2,QNR2/A,QNR6,QNR6/A,QN18,QP,QP/A,QPE2,QT,QT/A,QTC2,QTC2/A,QWH2,QWH2/A,QX,QX/A,QXB,QXB/A,QXB7,QXB7/A,QXC,QXC/A,QXC4,QXC4/A,QXC6,QXC6/A,QXC9,QXC9/A,QXE,QXE/A,QXEB,QXE2,QXE4,QXE4/A,QXE6,QXE6/A,QXE8,QXE8/A,QXQ4,QXQ4/A,QXU,QXU/A,QX2,Q1,Q1/A,SDE,SE,SE/A,SH,SH/A,SHB1,SHB3,SHB3/A,SHE,SHEZ,SHQ4,SHQ4/A,SHT,SJ,SJ/A,SJG,SJG/A,SKE,SKE/A,SKZ,SKZ/A,SME0,SME0/A,SME2,SMX2,SMX2/A,STJ,STJ/A,STP,STP/A,STQ,STQ/A,STR,STR/A,SWX,SWX/A,SX,SX/A,SXB,SXB/A,SXB7,SXB7/A,SXE,SXE/A,SXEB,SXEB/A,SXE2,SXE4,SXE4/A,SXE8,SXE8/A,SXP,SXQ4,SXQ4/A,SXU,SXU/A,S1,S1/A,VA,VAA,VAE,VAD2,VAD2/A,VAH1,VAH2,VAW1,VA2,VA2/A,VC2,VC2/A,VDE,VDE2,VDE2/A,VD16,VE,VEB6,VH,VHE,VH12,VH12/A,VH22,VH22/A,VMQ,VMX,VNG,VNG1,VNG2,VSH7,VS2,VS3,VS4,VS5,VS6,VS7,VTE2,VWA,VWA2,VWC,VWC2,VWC2/A,VWE,VWE2,VWE2/A,VWS2,VWS2/A,VW12,VW12/A,VX,VX/A,VXA,VXB,VXB/A,VXB2,VXB7,VXB7/A,VXE,VXE/A,VXEB,VXEB/A,VXE2,VXE2/A,VXE4,VXE6,VXE7,VXE7/A,VXE8,VXE8/A,VXG,VXK,VXQ4,VXQ4/A,VXU,VXU/A,VXU1,VXU1/A,VX16,VX16/A,VX8,VX8/A,V1,YJ
24	96100-62020-00	BEARING, RADIAL BALL, 6202 ..	1	1	-	-----	EDE2,EDE2/A,EDK,EDN,EDN2,EDN2/A,EDN5,EDN5/A,EDS,EDS1,EDS1/A,EDS2,EDS2/A,EDS3,EDS4,EDS5,EDS6,EDS6/A,EDT,EDT/A,EDT1,EDT1/A,EDT2,EDT3,EDT6,EDT6/A,ED6,ED6/A,ED7,ED8,ED8/A,ED9,ED9/A,EN,ENT,ENT/A,ENT2,EN6,EN6/A,ET,ETS,ETX,PKT2,PKT2/A,PKT4,PKT4/A,PKX2,PKX4,PKX4/A,PX,PX/A,PXA2,PXE8,PXE8/A,P1,P1/A,QA,QAB2,QAB2/A,QAC2,QAC2/A,QAE,QAE2,QAE2/A,QAE6,QAE6/A,QAG,QAG/A,QAQ2,QAQ2/A,QAP,QAPE,QAP2,QAP2/A,QAQ,QA2,QA2/A,QA26,QA26/A,QDW9,QDW9/A,QE,QE/A,QH,QH/A,QHB3,QHB3/A,QHB5,QHC,QHE,QHE/A,QHP1,QHP1/A,QHQ4,QHQ4/A,QH2,QKA4,QKA4/A,QL2,QMEO,QMEO/A,QME8,QME8/A,QMH,QMH/A,QMT2,QMT2/A,QMX2,QNE,QNE2,QNE2/A,QNE6,QNE9,QNE9/A,QNR2,QNR2/A,QNR6,QNR6/A,QN18,QP,QP/A,QPE2,QT,QT/A,QTC2,QTC2/A,QWH2,QWH2/A,QX,QX/A,QXB,QXB/A,QXB7,QXB7/A,QXC,QXC/A,QXC4,QXC4/A,QXC6,QXC6/A,QXC9,QXC9/A,QXE,QXE/A,QXEB,QXE2,QXE4,QXE4/A,QXE6,QXE6/A,QXE8,QXE8/A,QXQ4,QXQ4/A,QXU,QXU/A,QX2,Q1,Q1/A,SDE,SE,SE/A,SH,SH/A,SHB1,SHB3,SHB3/A,SHE,SHEZ,SHQ4,SHQ4/A,SHT,SJ,SJ/A,SJG,SJG/A,SKE,SKE/A,SKZ,SKZ/A,SME0,SME0/A,SME2,SMX2,SMX2/A,STJ,STJ/A,STP,STP/A,STQ,STQ/A,STR,STR/A,SWX,SWX/A,SX,SX/A,SXB,SXB/A,SXB7,SXB7/A,SXE,SXE/A,SXEB,SXEB/A,SXE2,SXE4,SXE4/A,SXE8,SXE8/A,SXP,SXQ4,SXQ4/A,SXU,SXU/A,S1,S1/A,VA,VAA,VAE,VAD2,VAD2/A,VAH1,VAH2,VAW1,VA2,VA2/A,VC2,VC2/A,VDE,VDE2,VDE2/A,VD16,VE,VEB6,VH,VHE,VH12,VH12/A,VH22,VH22/A,VMQ,VMX,VNG,VNG1,VNG2,VSH7,VS2,VS3,VS4,VS5,VS6,VS7,VTE2,VWA,VWA2,VWC,VWC2,VWC2/A,VWE,VWE2,VWE2/A,VWS2,VWS2/A,VW12,VW12/A,VX,VX/A,VXA,VXB,VXB/A,VXB2,VXB7,VXB7/A,VXE,VXE/A,VXEB,VXEB/A,VXE2,VXE2/A,VXE4,VXE6,VXE7,VXE7/A,VXE8,VXE8/A,VXG,VXK,VXQ4,VXQ4/A,VXU,VXU/A,VXU1,VXU1/A,VX16,VX16/A,VX8,VX8/A,V1,YJ



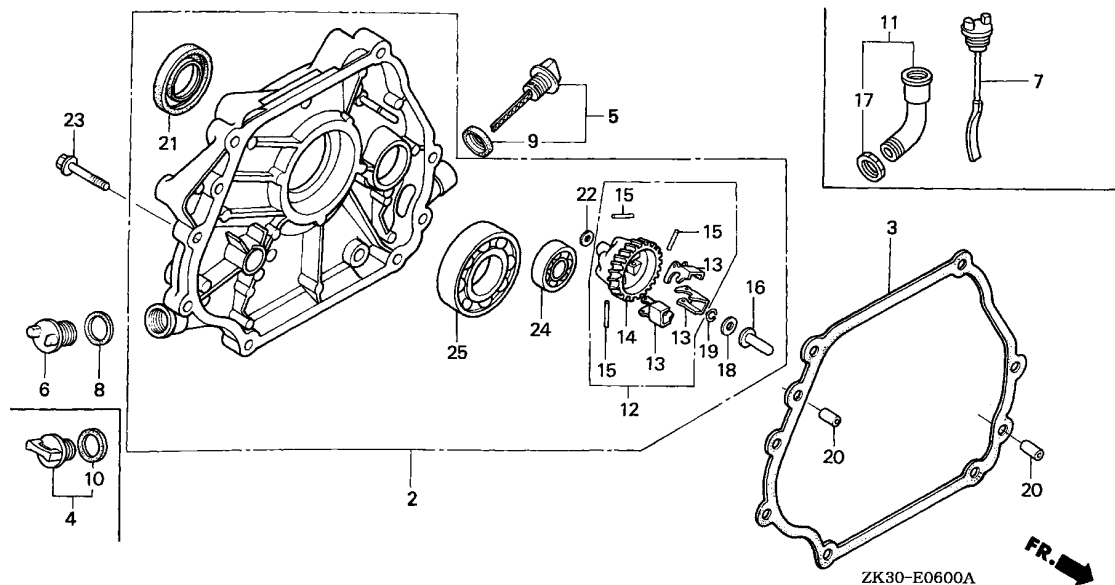

Ref. No.	Part No.	Description	Reqd. QTY			Serial No.	Parts catalogue code
			GX	340K1	(3)		
25	96100-62070-00	BEARING, RADIAL BALL, 6207 ..	1	1	-	-----	EDE2,EDE2/A,EDK,EDN,EDN2,EDN2/A,EDN5,EDN5/A,EDS,EDS1,EDS1/A,EDS2,EDS2/A,EDS3,EDS4,EDS5,EDS6,EDS6/A,EDT,EDT/A,EDT1,EDT1/A,EDT2,EDT3,EDT6,EDT6/A,ED6,ED6/A,ED7,ED8,ED8/A,ED9,ED9/A,EN,ENT,ENT/A,ENT2,EN6,EN6/A,ET,ETS,ETX,PKT2,PKT2/A,PKT4,PKT4/A,PKX2,PKX4,PKX4/A,PX,PX/A,PXA2,PXE8,PXE8/A,P1,P1/A,QA,QAB2,QAB2/A,QAC2,QAC2/A,QAE,QAE2,QAE2/A,QAE6,QAE6/A,QAG,QAG/A,QA2,QA2/A,QAP,QAPE,QAP2,QAP2/A,QAQ,QA2,QA2/A,QA26,QA26/A,QDW9,QDW9/A,QE,QE/A,QH,QH/A,QHB3,QHB3/A,QHB5,QHC,QHE,QHE/A,QHP1,QHP1/A,QHQ4,QHQ4/A,QH2,QKA4,QKA4/A,QL2,QME0,QME0/A,QME8,QME8/A,QMH,QMH/A,QMT2,QMT2/A,QMX2,QNE,QNE2,QNE2/A,QNE6,QNE9,QNE9/A,QNR2,QNR2/A,QNR6,QNR6/A,QN18,QP,QP/A,QPE2,QT,QT/A,QTC2,QTC2/A,QWH2,QWH2/A,QX,QX/A,QXB,QXB/A,QXB7,QXB7/A,QXC,QXC/A,QXC4,QXC4/A,QXC6,QXC6/A,QXC9,QXC9/A,QXE,QXE/A,QXEB,QXE2,QXE4,QXE4/A,QXE6,QXE6/A,QXE8,QXE8/A,QXQ4,QXQ4/A,QXU,QXU/A,QX2,Q1,Q1/A,SDE,SE,SE/A,SH,SH/A,SHB1,SHB3,SHB3/A,SHE,SHEZ,SHQ4,SHQ4/A,SHT,SJ,SJ/A,SJ6,SJ6/A,SKE,SKE/A,SKZ,SKZ/A,SME0,SME0/A,SME2,SMX2,SMX2/A,STJ,STJ/A,STP,STP/A,STQ,STQ/A,STR,STR/A,SWX,SWX/A,SX,SX/A,SXB,SXB/A,SXB7,SXB7/A,SXE,SXE/A,SXEB,SXEB/A,SXE2,SXE4,SXE4/A,SXE8,SXE8/A,SXP,SXQ4,SXQ4/A,SXU,SXU/A,S1,S1/A,VA,VAA,VAAE,VAD2,VAD2/A,VAH1,VAH2,VAW1,VA2,VA2/A,VC2,VC2/A,VDE,VDE2,VDE2/A,VD16,VE,VEB6,VH,VHE,VH12,VH12/A,VH22,VH22/A,VMQ,VMX,VNG,VNG1,VNG2,VSH7,VS2,VS3,VS4,VS5,VS6,VS7,VTE2,VWA,VWA2,VWC,VWC2,VWC2/A,VWE,VWE2,VWE2/A,VWS2,VWS2/A,VW12,VW12/A,VX,VX/A,VXA,VXB,VXB/A,VXB2,VXB7,VXB7/A,VXE,VXE/A,VXEB,VXEB/A,VXE2,VXE2/A,VXE4,VXE6,VXE7,VXE7/A,VXE8,VXE8/A,VXG,VXK,VXQ4,VXQ4/A,VXU,VXU/A,VXU1,VXU1/A,VX16,VX16/A,VX8,VX8/A,V1,YJ
			-	-	1		

E-6-1

CRANKCASE COVER(2)

G13

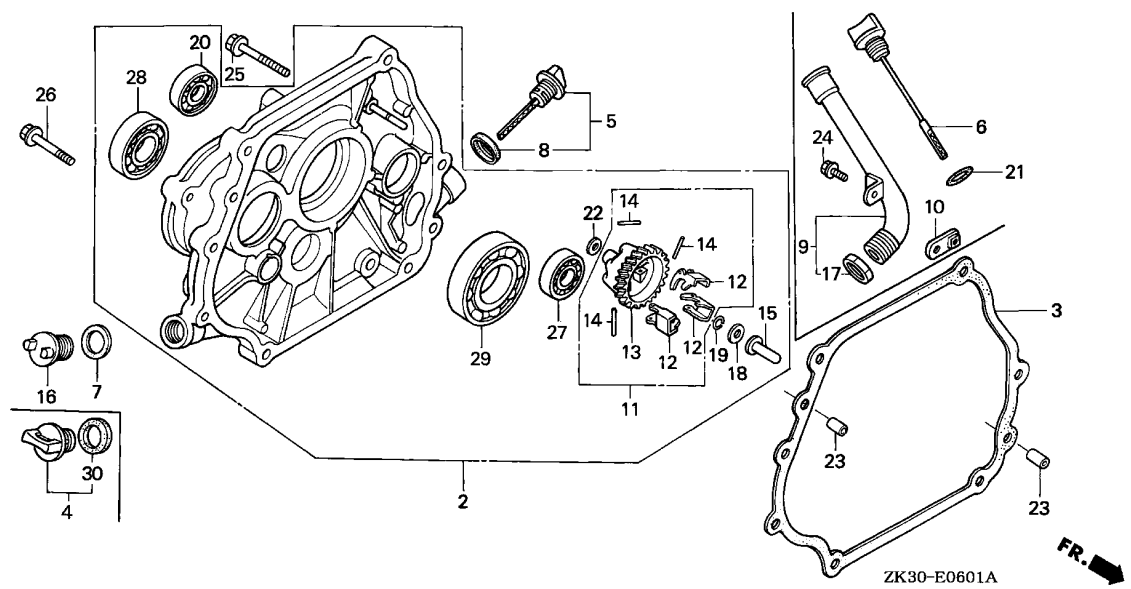

Ref. No.	L.O.N.	(Relative ref. Number) Description	F.R.T.
2	1101G0	COVER, CRANKCASE(A) .....	0.3
3	1101F9	PACKING, CRANKCASE COVER(A) ..	0.3
9	1101B9	EXTENSION, OIL FILLER AND/OR PACKING, OIL FILLER EXTENSION (12)	0.1
13	1161C6	HOLDER, GOVERNOR WEIGHT(A) ...	0.4
15	1161C7	SLIDER, GOVERNOR(A) .....	0.4
20	2101U3	BEARING, COUNTERSHAFT :FRONT	0.4
27	1101F5	BEARING, BALANCER WEIGHT :REAR	0.4
28	2141A7	BEARING, POWER TAKE OFF SHAFT :FRONT .....	0.4
29	1101A6	BEARING, CRANKSHAFT :REAR ....	0.4

Ref. No.	Part No.	Description	Reqd. QTY			Serial No.	Parts catalogue code
			GX	340K1	(3)		
2	11300-ZE3-612	COVER ASSY., CRANKCASE .....	1	1	-	3460754	HA2,HX26,LH,LHB3,LHE,LHQ4,LJ,LJG,LKE,LT,LWD1,LX,LXE,LXE2,LXE4,LXE8,LXQ4,LXU,LX2,LX26,L1,ZK1
	11300-ZE3-W00	.....	1	-	-		BJ,HA,HAQ,HH,HX,HX2,LHB1,LHC,LHW,LSX,LXE6,LXZ
	11300-ZE3-614	.....	1	1	-		LP
			1	1	-		HA2/A,HX26/A,LH/A,LHB3/A,LHB5,LHE/A,LHQ4/A,LJ/A,LJG/A,LJS,LJS/A,LJS1,LKE/A,LT/A,LWD,LWD1/A,LX/A,LXE/A,LXE2/A,LXE4/A,LXE8/A,LXQ4/A,LXU/A,LX2/A,LX26/A,L1/A,ZK1/A
3	11381-ZE3-000	PACKING, CASE COVER .....	1	(1)	-	2178372	HA2,HX26,LH,LHB3,LHE,LHQ4,LJ,LJG,LKE,LT,LWD1,LX,LXE,LXE2,LXE4,LXE8,LXQ4,LXU,LX2,LX26,L1,ZK1
	11381-ZE3-800	.....	1	-	-	3279758	BJ,LJ,LP,LXZ,L1
			1	-	-	2178373	HA2,HX26,LH,LHB3,LHE,LHQ4,LKE,LT,LX,LXE,LXE2,LXE4,LXE8,LXQ4,LXU,LX2,LX26,ZK1
	11381-ZE3-801	.....	1	(1)	-		LJ
			1	(1)	-		HA,HAQ,HA2/A,HH,HX,HX2,HX26/A,LH/A,LHB1,LHB3/A,LHB5,LHC,LHE/A,LHQ4/A,LHW,LJ/A,LJG,LJG/A,LJS,LJS/A,LJS1,LKE/A,LSX,LT/A,LWD,LWD1/A,LX/A,LXE/A,LXE2/A,LXE4/A,LXE6,LXE8/A,LXQ4/A,LXU/A,LX2/A,LX26/A,L1/A,ZK1/A
			1	(1)	-	2178373	BJ,LP,LXZ,L1
			1	-	-	3279759	HA2,HX26,LH,LHB3,LHE,LHQ4,LJ,LKE,LT,LX,LXE,LXE2,LXE4,LXE8,LXQ4,LXU,LX2,LX26,ZK1
4	15600-ZG4-003	CAP ASSY., OIL FILLER .....	1	1	-		HA,HA2,HA2/A,HX2,HX26,HX26/A,LH/A,LHB1,LHB3,LHB3/A,LHB5,LHE/A,LHQ4,LHQ4/A,LHW,LJ/A,LJG,LJG/A,LJS,LJS/A,LJS1,LKE/A,LT,LT/A,LWD,LWD1/A,LX/A,LXE/A,LXE2/A,LXE4,LXE4/A,LXE6,LXE8,LXE8/A,LXQ4,LXQ4/A,LXU,LXU/A,LX2,LX2/A,LX26,LX26/A,L1/A,ZK1,ZK1/A
			1	1	-	2259155	BJ,HAQ,HH,HX,LH,LHC,LHE,LJ,LKE,LP,LX,LXE,LXZ,L1

2

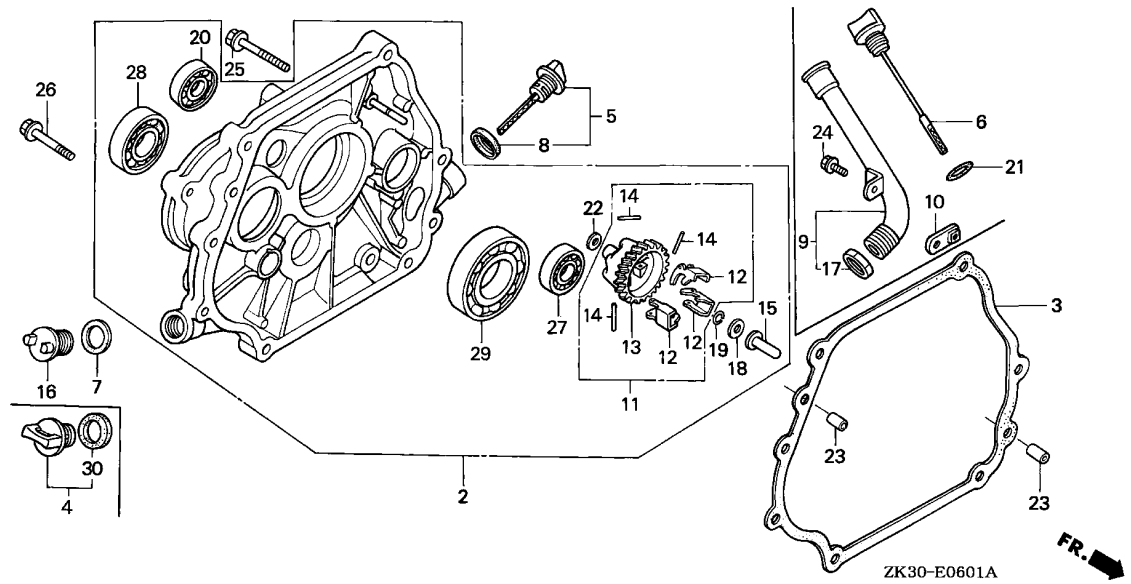

Ref. No.	Part No.	Description	Reqd. QTY			Serial No.	Parts catalogue code
			(1)	(2)	(3)		
5	15600-735-003	CAP ASSY., OIL FILLER .....	1	1	-	BJ, HA, HAQ, HA2, HA2/A, HH, HX, HX2, HX26, HX26/A, LH, LH/A, LHB1, LHB3, LHB3/A, LHB5, LHC, LHE, LHE/A, LHQ4, LHQ4/A, LHW, LJ, LJ/A, LJG, LJG/A, LJS, LJS/A, LJS1, LKE, LKE/A, LSX, LT, LT/A, LWD, LWD1, LWD1/A, LX, LX/A, LXE, LXE/A, LXE2, LXE2/A, LXE4, LXE4/A, LXE6, LXE8, LXE8/A, LXQ4, LXQ4/A, LXU, LXU/A, LXZ, LX2, LX2/A, LX26, LX26/A, L1, L1/A, ZK1, ZK1/A	
6	15620-ZE3-L60 15620-ZE3-L61	GAUGE COMP., OIL LEVEL .....	1	-	-	2375015 ZK1 ZK1/A	
7	15621-896-010	PACKING, OIL FILLER CAP .....	1	1	-	2259154 ZK1	
8	15625-ZE1-003	PACKING, OIL FILLER CAP .....	1	1	-	BJ, HA, HAQ, HA2, HA2/A, HH, HX, HX2, HX26, HX26/A, LH, LH/A, LHB1, LHB3, LHB3/A, LHB5, LHC, LHE, LHE/A, LHQ4, LHQ4/A, LHW, LJ, LJ/A, LJG, LJG/A, LJS, LJS/A, LJS1, LKE, LKE/A, LSX, LT, LT/A, LWD, LWD1, LWD1/A, LX, LX/A, LXE, LXE/A, LXE2, LXE2/A, LXE4, LXE4/A, LXE6, LXE8, LXE8/A, LXQ4, LXQ4/A, LXU, LXU/A, LXZ, LX2, LX2/A, LX26, LX26/A, L1, L1/A, ZK1, ZK1/A	
9	15630-ZE3-L60	EXTENSION COMP., OIL FILLER .....	1	-	-	ZK1, ZK1/A	
10	15634-ZE3-L60	PLATE, EXTENSION .....	1	-	-	ZK1, ZK1/A	
11	16510-ZE3-000	GOVERNOR ASSY. ....	1	1	-	BJ, HA, HAQ, HA2, HA2/A, HH, HX, HX2, HX26, HX26/A, LH, LH/A, LHB1, LHB3, LHB3/A, LHB5, LHC, LHE, LHE/A, LHQ4, LHQ4/A, LHW, LJ, LJ/A, LJG, LJG/A, LJS, LJS/A, LJS1, LKE, LKE/A, LSX, LT, LT/A, LWD, LWD1, LWD1/A, LX, LX/A, LXE, LXE/A, LXE2, LXE2/A, LXE4, LXE4/A, LXE6, LXE8, LXE8/A, LXQ4, LXQ4/A, LXU, LXU/A, LXZ, LX2, LX2/A, LX26, LX26/A, L1, L1/A, ZK1, ZK1/A	
12	16511-ZE8-000	WEIGHT, GOVERNOR .....	3	3	-	BJ, HA, HAQ, HA2, HA2/A, HH, HX, HX2, HX26, HX26/A, LH, LH/A, LHB1, LHB3, LHB3/A, LHB5, LHC, LHE, LHE/A, LHQ4, LHQ4/A, LHW, LJ, LJ/A, LJG, LJG/A, LJS, LJS/A, LJS1, LKE, LKE/A, LSX, LT, LT/A, LWD, LWD1, LWD1/A, LX, LX/A, LXE, LXE/A, LXE2, LXE2/A, LXE4, LXE4/A, LXE6, LXE8, LXE8/A, LXQ4, LXQ4/A, LXU, LXU/A, LXZ, LX2, LX2/A, LX26, LX26/A, L1, L1/A, ZK1, ZK1/A	



Ref. No.	Part No.	Description	Reqd. QTY			Serial No.	Parts catalogue code
			(1)	(2)	(3)		
13	16512-ZE3-000	HOLDER, GOVERNOR WEIGHT .....	1	1	-	-----	BJ,HA,HAQ,HA2,HA2/A,HH,HX,HX2,HX26,HX26/A,LH,LH/A,LHB1,LHB3,LHB3/A,LHB5,LHC,LHE,LHE/A,LHQ4,LHQ4/A,LHW,LJ,LJ/A,LJG,LJG/A,LJS,LJS/A,LJS1,LKE,LKE/A,LSX,LT,LT/A,LWD,LWD1,LWD1/A,LX,LX/A,LXE,LXE/A,LXE2,LXE2/A,LXE4,LXE4/A,LXE6,LXE8,LXE8/A,LXQ4,LXQ4/A,LXU,LXU/A,LXZ,LX2,LX2/A,LX26,LX26/A,L1,L1/A,ZK1,ZK1/A
14	16513-ZE2-000	PIN, GOVERNOR WEIGHT .....	3	3	-	-----	BJ,HA,HAQ,HA2,HA2/A,HH,HX,HX2,HX26,HX26/A,LH,LH/A,LHB1,LHB3,LHB3/A,LHB5,LHC,LHE,LHE/A,LHQ4,LHQ4/A,LHW,LJ,LJ/A,LJG,LJG/A,LJS,LJS/A,LJS1,LKE,LKE/A,LSX,LT,LT/A,LWD,LWD1,LWD1/A,LX,LX/A,LXE,LXE/A,LXE2,LXE2/A,LXE4,LXE4/A,LXE6,LXE8,LXE8/A,LXQ4,LXQ4/A,LXU,LXU/A,LXZ,LX2,LX2/A,LX26,LX26/A,L1,L1/A,ZK1,ZK1/A
15	16531-ZE2-000	SLIDER, GOVERNOR .....	1	1	-	-----	3460754 HA2,HX26,LH,LHB3,LHE,LHQ4,LJ,LJG,LKE,LT,LWD1,LX,LXE,LXE2,LXE4,LXE8,LXQ4,LXU,LX2,LX26,L1,ZK1
	16531-Z0A-000	.....	1	1	-	-----	BJ,HA,HAQ,HA2/A,HH,HX,HX2,HX26/A,LH/A,LHB1,LHB3/A,LHB5,LHC,LHE/A,LHQ4/A,LHW,LJ/LJ/A,LJG/A,LJS,LJS/A,LJS1,LKE/A,LSX,LT/A,LWD,LWD1/A,LX/A,LXE/A,LXE2/A,LXE4/A,LXE6,LXE8/A,LXQ4/A,LXU/A,LXZ,LX2/A,LX26/A,L1/A,ZK1/A
			1	1	-	3460755	----- HA2,HX26,LH,LHB3,LHE,LHQ4,LJ,LJG,LKE,LT,LWD1,LX,LXE,LXE2,LXE4,LXE8,LXQ4,LXU,LX2,LX26,L1,ZK1
16	15620-ZG4-910	CAP, OIL FILLER .....	1	1	-	-----	2259154 BJ,HAQ,HH,HX,LH,LHC,LHE,LJ,LKE,LP,LX,LXE,LXZ,L1
17	90011-883-630	NUT, OIL FILLER .....	1	-	-	-----	ZK1,ZK1/A
18	90473-147-000	WASHER, 6X16 .....	1	1	-	-----	BJ,HA,HAQ,HA2,HA2/A,HH,HX,HX26,HX26/A,LH,LH/A,LHB3,LHB3/A,LHC,LHE,LHE/A,LHQ4,LHQ4/A,LJ,LJ/A,LJG,LJG/A,LKE,LKE/A,LT,LT/A,LWD1,LWD1/A,LX,LX/A,LXE,LXE/A,LXE2,LXE2/A,LXE4,LXE4/A,LXE8,LXE8/A,LXQ4,LXQ4/A,LXU,LXU/A,LXZ,LX2,LX2/A,LX26,LX26/A,L1,L1/A,ZK1,ZK1/A
19	90602-ZE1-000	CLIP, GOVERNOR HOLDER .....	1	1	-	-----	BJ,HA,HAQ,HA2,HA2/A,HH,HX,HX2,HX26,HX26/A,LH,LH/A,LHB1,LHB3,LHB3/A,LHB5,LHC,LHE,LHE/A,LHQ4,LHQ4/A,LHW,LJ,LJ/A,LJG,LJG/A,LJS,LJS/A,LJS1,LKE,LKE/A,LSX,LT,LT/A,LWD,LWD1,LWD1/A,LX,LX/A,LXE,LXE/A,LXE2,LXE2/A,LXE4,LXE4/A,LXE6,LXE8,LXE8/A,LXQ4,LXQ4/A,LXU,LXU/A,LXZ,LX2,LX2/A,LX26,LX26/A,L1,L1/A,ZK1,ZK1/A
20	91009-KJ1-003	BEARING, RADIAL BALL, 6202 (NTN)	1	1	-	-----	BJ,HA,HAQ,HA2,HA2/A,HH,HX,HX2,HX26,HX26/A,LH,LH/A,LHB1,LHB3,LHB3/A,LHB5,LHC,LHE,LHE/A,LHQ4,LHQ4/A,LHW,LJ,LJ/A,LJG,LJG/A,LJS,LJS/A,LJS1,LKE,LKE/A,LP,LSX,LT,LT/A,LWD,LWD1,LWD1/A,LX,LX/A,LXE,LXE/A,LXE2,LXE2/A,LXE4,LXE4/A,LXE6,LXE8,LXE8/A,LXQ4,LXQ4/A,LXU,LXU/A,LXZ,LX2,LX2/A,LX26,LX26/A,L1,L1/A,ZK1,ZK1/A
21	91303-800-000	O-RING, 16MM .....	1	-	-	-----	ZK1,ZK1/A
22	94101-06800	WASHER, PLAIN, 6MM .....	1	1	-	-----	BJ,HA,HAQ,HA2,HA2/A,HH,HX,HX2,HX26,HX26/A,LH,LH/A,LHB1,LHB3,LHB3/A,LHB5,LHC,LHE,LHE/A,LHQ4,LHQ4/A,LHW,LJ,LJ/A,LJG,LJG/A,LJS,LJS/A,LJS1,LKE,LKE/A,LSX,LT,LT/A,LWD,LWD1,LWD1/A,LX,LX/A,LXE,LXE/A,LXE2,LXE2/A,LXE4,LXE4/A,LXE6,LXE8,LXE8/A,LXQ4,LXQ4/A,LXU,LXU/A,LXZ,LX2,LX2/A,LX26,LX26/A,L1,L1/A,ZK1,ZK1/A
23	90701-HC4-000	DOWEL PIN, 8X12 .....	2	2	-	-----	BJ,HA,HAQ,HA2,HA2/A,HH,HX,HX2,HX26,HX26/A,LH,LH/A,LHB1,LHB3,LHB3/A,LHB5,LHC,LHE,LHE/A,LHQ4,LHQ4/A,LHW,LJ,LJ/A,LJG,LJG/A,LJS,LJS/A,LJS1,LKE,LKE/A,LP,LSX,LT,LT/A,LWD,LWD1,LWD1/A,LX,LX/A,LXE,LXE/A,LXE2,LXE2/A,LXE4,LXE4/A,LXE6,LXE8,LXE8/A,LXQ4,LXQ4/A,LXU,LXU/A,LXZ,LX2,LX2/A,LX26,LX26/A,L1,L1/A,ZK1,ZK1/A
24	95701-06012-00	BOLT, FLANGE, 6X12 .....	2	-	-	-----	ZK1,ZK1/A
25	95701-08040-00	BOLT, FLANGE, 8X40 .....	1	1	-	-----	BJ,HA,HAQ,HA2,HA2/A,HH,HX,HX2,HX26,HX26/A,LH,LH/A,LHB1,LHB3,LHB3/A,LHB5,LHC,LHE,LHE/A,LHQ4,LHQ4/A,LHW,LJ,LJ/A,LJG,LJG/A,LJS,LJS/A,LJS1,LKE,LKE/A,LP,LSX,LT,LT/A,LWD,LWD1,LWD1/A,LX,LX/A,LXE,LXE/A,LXE2,LXE2/A,LXE4,LXE4/A,LXE6,LXE8,LXE8/A,LXQ4,LXQ4/A,LXU,LXU/A,LXZ,LX2,LX2/A,LX26,LX26/A,L1,L1/A
	95701-08045-00	BOLT, FLANGE, 8X45 .....	1	-	-	-----	ZK1,ZK1/A



E-6-1

CRANKCASE COVER(2)

G16

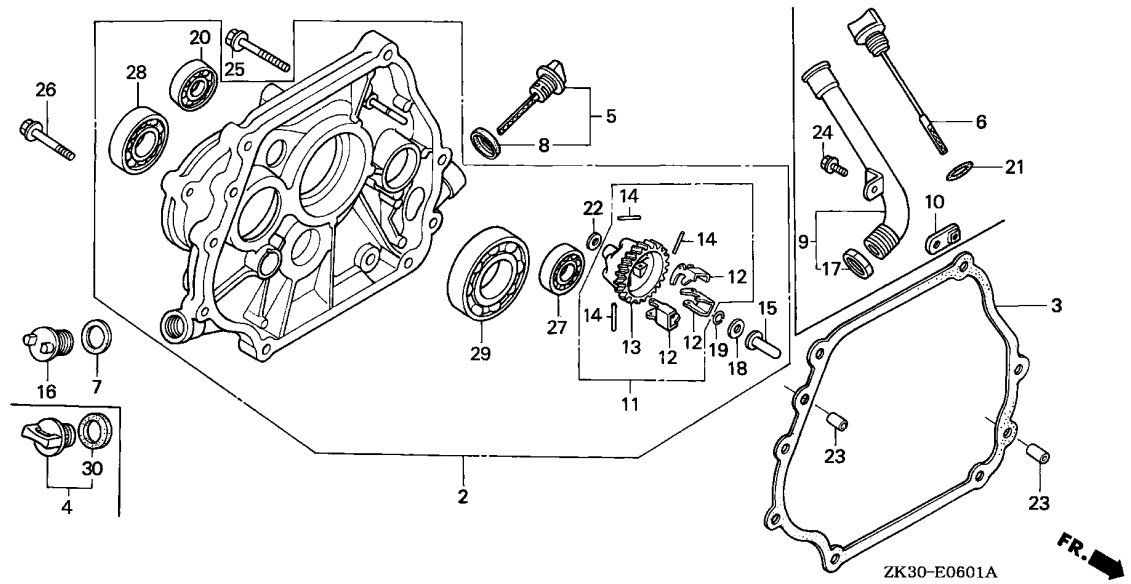

Ref. No.	Part No.	Description	Reqd. QTY			Serial No.	Parts catalogue code	
			(1)	(2)	(3)			
26	95701-08040-00	BOLT, FLANGE, 8X40 .....	6	6	-	-----	BJ,HA,HAQ,HA2,HA2/A,HH,HX,HX2,HX26,HX26/A,LH,LH/A,LHB1,LHB3,LHB3/A,LHB5,LHC,LHE,LHE/A,LHQ4,LHQ4/A,LHW,LJ,LJ/A,LJG,LJG/A,LJS,LJS/A,LJS1,LKE,LKE/A,LP,LSX,LT,LT/A,LWD,LWD1,LWD1/A,LX,LX/A,LXE,LXE/A,LXE2,LXE2/A,LXE4,LXE4/A,LXE6,LXE8,LXE8/A,LXQ4,LXQ4/A,LXU,LXU/A,LXZ,LX2,LX2/A,LX26,LX26/A,L1,L1/A,ZK1,ZK1/A	
27	96100-62020-00	BEARING, RADIAL BALL, 6202 ..	1	1	-	-----	BJ,HA,HAQ,HA2,HA2/A,HH,HX,HX2,HX26,HX26/A,LH,LH/A,LHB1,LHB3,LHB3/A,LHB5,LHC,LHE,LHE/A,LHQ4,LHQ4/A,LHW,LJ,LJ/A,LJG,LJG/A,LJS,LJS/A,LJS1,LKE,LKE/A,LP,LSX,LT,LT/A,LWD,LWD1,LWD1/A,LX,LX/A,LXE,LXE/A,LXE2,LXE2/A,LXE4,LXE4/A,LXE6,LXE8,LXE8/A,LXQ4,LXQ4/A,LXU,LXU/A,LXZ,LX2,LX2/A,LX26,LX26/A,L1,L1/A,ZK1,ZK1/A	
28	96100-62040-00	BEARING, RADIAL BALL, 6204 ..	1	1	-	-----	BJ,HA,HAQ,HA2,HA2/A,HH,HX,HX2,HX26,HX26/A,LH,LH/A,LHB1,LHB3,LHB3/A,LHB5,LHC,LHE,LHE/A,LHQ4,LHQ4/A,LHW,LJ,LJ/A,LJG,LJG/A,LJS,LJS/A,LJS1,LKE,LKE/A,LP,LSX,LT,LT/A,LWD,LWD1,LWD1/A,LX,LX/A,LXE,LXE/A,LXE2,LXE2/A,LXE4,LXE4/A,LXE6,LXE8,LXE8/A,LXQ4,LXQ4/A,LXU,LXU/A,LXZ,LX2,LX2/A,LX26,LX26/A,L1,L1/A,ZK1,ZK1/A	
29	96100-62070-00	BEARING, RADIAL BALL, 6207 ..	1	1	-	-----	BJ,HA,HAQ,HA2,HA2/A,HH,HX,HX2,HX26,HX26/A,LH,LH/A,LHB1,LHB3,LHB3/A,LHB5,LHC,LHE,LHE/A,LHQ4,LHQ4/A,LHW,LJ,LJ/A,LJG,LJG/A,LJS,LJS/A,LJS1,LKE,LKE/A,LP,LSX,LT,LT/A,LWD,LWD1,LWD1/A,LX,LX/A,LXE,LXE/A,LXE2,LXE2/A,LXE4,LXE4/A,LXE6,LXE8,LXE8/A,LXQ4,LXQ4/A,LXU,LXU/A,LXZ,LX2,LX2/A,LX26,LX26/A,L1,L1/A,ZK1,ZK1/A	
30	15625-ZE1-003	PACKING, OIL FILLER CAP .....	1	1	-	-----	HA,HA2,HA2/A,HX2,HX26,HX26/A,LH/A,LHB1,LHB3,LHB3/A,LHB5,LHE/A,LHQ4,LHQ4/A,LHW,LJ/A,LJG,LJG/A,LJS,LJS/A,LJS1,LKE/A,LT,LT/A,LWD,LWD1,LWD1/A,LX/A,LXE/A,LXE2,LXE2/A,LXE4,LXE4/A,LXE6,LXE8,LXE8/A,LXQ4,LXQ4/A,LXU,LXU/A,LX2,LX2/A,LX26,LX26/A,L1/A,ZK1,ZK1/A	
			1	1	-	2259155	-----	BJ,HAQ,HH,HX,LH,LHC,LHE,LJ,LKE,LP,LX,LXE,LXZ,L1

2

E-6-2

CRANKCASE COVER(3)

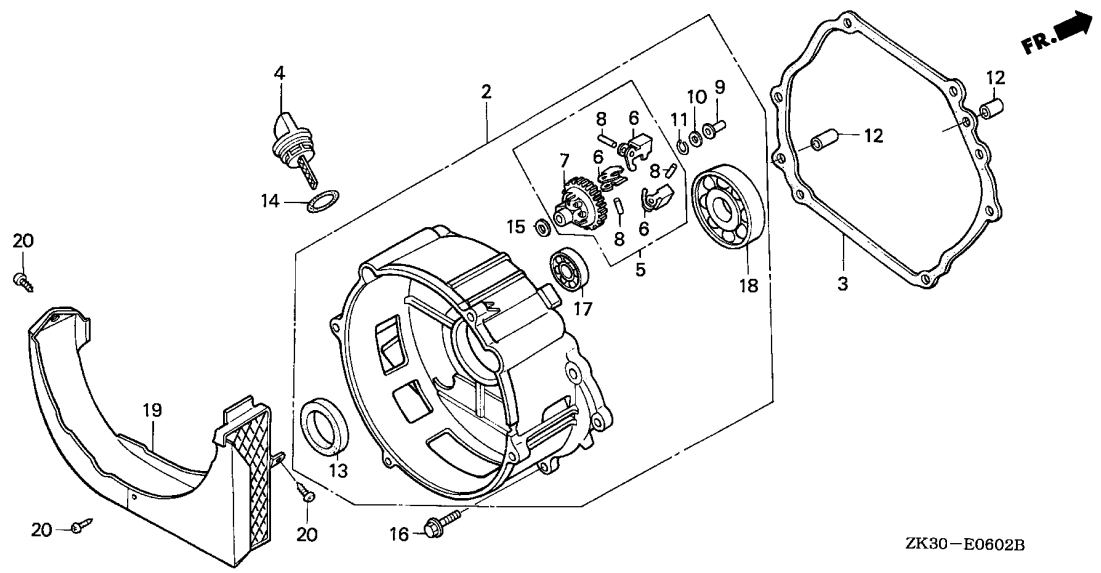

ZK30-E0602B

Ref. No.	L.O.N.	(Relative ref. Number) Description	F.R.T.
2	1101G1	COVER, CRANKCASE(B)	0.3
3	1101F9	PACKING, CRANKCASE COVER(A) (6)	0.3
7	1161C6	HOLDER, GOVERNOR WEIGHT(A)	0.4
9	1161C7	SLIDER, GOVERNOR(A)	0.4
13	1101G3	OIL SEAL, CRANKCASE COVER	0.4
17	1101G5	BEARING, BALANCER WEIGHT(A) :REAR	0.5
18	1101G4	BEARING, CRANKSHAFT(A) :REAR	0.5
19	4141J5	COVER, DUCT	0.1

Ref. No.	Part No.	Description	Reqd. QTY			Serial No.	Parts catalogue code
			GX	340K1	(3)		
			(1)	(2)	(3)		
2	11300-ZE3-702	COVER ASSY., CRANKCASE	1	-	-	ES	
			1	-	-	2702384	ES1
			1	-	-	3460754	ES3,ES4,VMT
	11300-ZE3-F50		1	-	-	2702385	3460754
	11300-ZE3-704		1	-	-		ES1
			1	-	-		EMT,EMT/A,ES3/A,ES4/A,VMT/A
	11300-ZE3-F52		1	-	-	3460755	ES3,ES4,VMT
			1	-	-		ES1/A,ES2
			1	-	-	3460755	ES1
3	11381-ZE3-800	PACKING, CASE COVER	1	-	-	ES	
			1	-	-	3279758	ES1,ES3,ES4,VMT
	11381-ZE3-801		1	-	-		EMT,EMT/A,ES1/A,ES2,ES3/A,ES4/A,VMT/A
			1	-	-	3279759	ES1,ES3,ES4,VMT
4	15620-ZE2-700	CAP, OIL FILLER	1	-	-		EMT,EMT/A,ES,ES1,ES1/A,ES2,ES3,ES3/A,ES4,ES4/A,VMT,VMT/A
5	16510-ZE3-000	GOVERNOR ASSY.	1	-	-		EMT,EMT/A,ES,ES1,ES1/A,ES2,ES3,ES3/A,ES4,ES4/A,VMT,VMT/A
6	16511-ZE8-000	WEIGHT, GOVERNOR	3	-	-		EMT,EMT/A,ES,ES1,ES1/A,ES2,ES3,ES3/A,ES4,ES4/A,VMT,VMT/A
7	16512-ZE3-000	HOLDER, GOVERNOR WEIGHT	1	-	-		EMT,EMT/A,ES,ES1,ES1/A,ES2,ES3,ES3/A,ES4,ES4/A,VMT,VMT/A
8	16513-ZE2-000	PIN, GOVERNOR WEIGHT	3	-	-		EMT,EMT/A,ES,ES1,ES1/A,ES2,ES3,ES3/A,ES4,ES4/A,VMT,VMT/A
9	16531-ZE2-000	SLIDER, GOVERNOR	1	-	-	3460754	ES1,ES3,ES4,VMT
	16531-Z0A-000		1	-	-		EMT,EMT/A,ES,ES1/A,ES2,ES3/A,ES4/A,VMT/A
			1	-	-	3460755	ES1,ES3,ES4,VMT
10	90473-147-000	WASHER, 6X16	1	-	-	2240058	ES,ES1,ES3,ES4
11	90602-ZE1-000	CLIP, GOVERNOR HOLDER	1	-	-		EMT,EMT/A,ES,ES1,ES1/A,ES2,ES3,ES3/A,ES4,ES4/A,VMT,VMT/A
12	90701-HC4-000	DOWEL PIN, 8X12	2	-	-		EMT,EMT/A,ES,ES1,ES1/A,ES2,ES3,ES3/A,ES4,ES4/A,VMT,VMT/A
13	91201-ZE3-004	OIL SEAL, 35X52X8	1	-	-		EMT,EMT/A,ES,ES1,ES1/A,ES2,ES3,ES3/A,ES4,ES4/A,VMT,VMT/A
14	91301-805-000	O-RING, 26X2.7	1	-	-		EMT,EMT/A,ES,ES1,ES1/A,ES2,ES3,ES3/A,ES4,ES4/A,VMT,VMT/A
15	94101-06800	WASHER, PLAIN, 6MM	1	-	-		EMT,EMT/A,ES,ES1,ES1/A,ES2,ES3,ES3/A,ES4,ES4/A,VMT,VMT/A



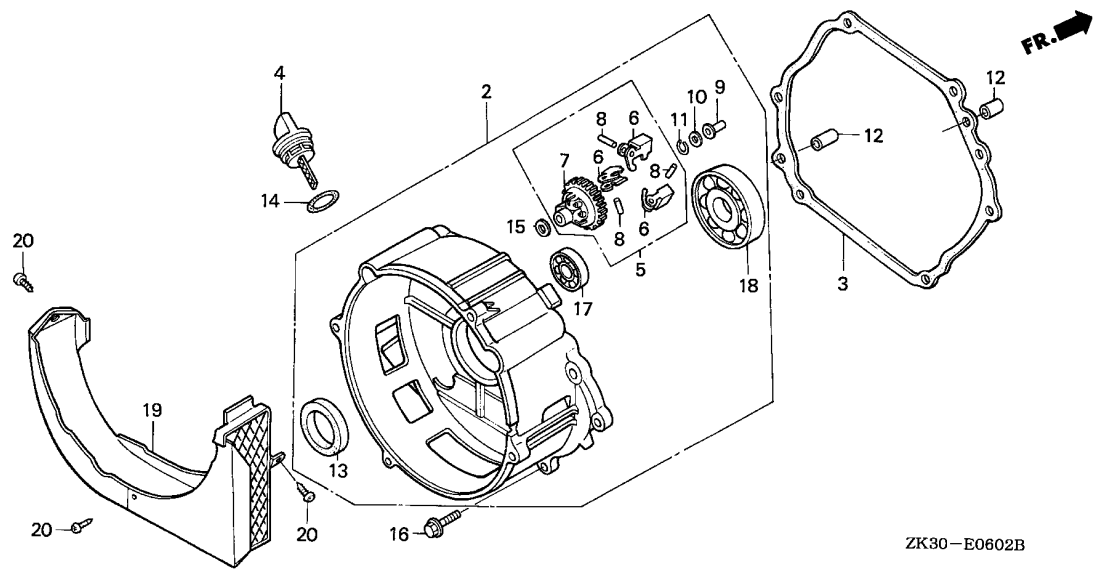

Ref. No.	Part No.	Description	Reqd. QTY			Serial No.	Parts catalogue code
			(1)	(2)	(3)		
16	95701-08040-00	BOLT, FLANGE, 8X40 .....	7	-	-	-----	EMT,EMT/A,ES,ES1,ES1/A,ES2,ES3,ES3/A,ES4,ES4/A,VMT,VMT/A
17	96100-62020-00	BEARING, RADIAL BALL, 6202 ..	1	-	-	-----	EMT,EMT/A,ES,ES1,ES1/A,ES2,ES3,ES3/A,ES4,ES4/A,VMT,VMT/A
18	96100-62070-00	BEARING, RADIAL BALL, 6207 ..	1	-	-	-----	EMT,EMT/A,ES,ES1,ES1/A,ES2,ES3,ES3/A,ES4,ES4/A,VMT,VMT/A
19	11315-ZE3-700	COVER, DUCT .....	1	-	-	-----	EMT,EMT/A,VMT,VMT/A
20	90019-883-000	BOLT, FLANGE, 5X10 .....	3	-	-	-----	EMT,EMT/A,VMT,VMT/A

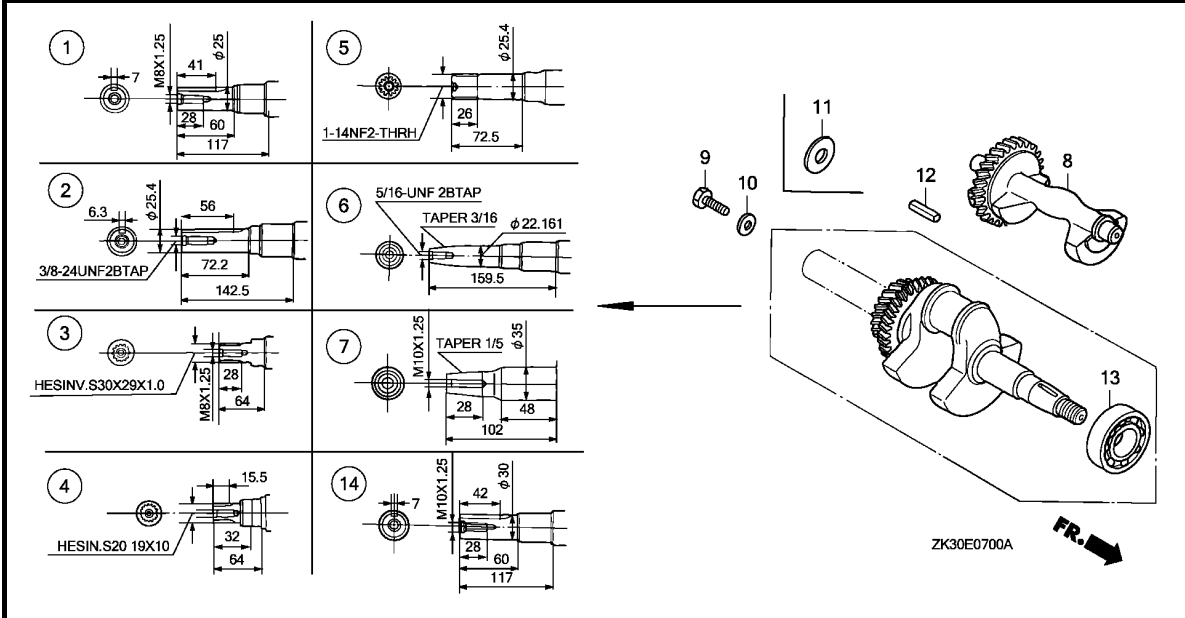

Ref. No.	L.O.N.	(Relative ref. Number) Description	F.R.T.
1		(2,3,4,5,6,7,14)	
1101F0		CRANKSHAFT .....	1.1
1101D8		WEIGHT, BALANCER .....	0.3
1101A4		BEARING, CRANKSHAFT :FRONT ...	1.3

Ref. No.	Part No.	Description	Reqd. QTY			Serial No.	Parts catalogue code
			GX	340K1			
			(1)	(2)	(3)		
1	13310-ZE3-010	CRANKSHAFT COMP. ....	1	1	-	-----	SDE,SE,SH,SHB1,SHB3,SHE,SHEZ,SHQ4,SHT,SJ,SJG,SKE,SKZ,SME0,SME2,SMX2,STJ,STP,STQ,STR,SWX,SX,SBX,SXE,SXEB,SXE2,SXE4,SXE8,SXP,SXQ4,SXU,S1
	13310-ZK3-000	.....	1	-	-	-----	4105385 SE/A,SH/A,SHB3/A,SHQ4/A,SJ/A,SJG/A,SKE/A,SKZ/A,SME0/A,SMX2/A,STJ/A,STP/A,STQ/A,STR/A,SWX/A,SX/A,SBX/A,SXE/A,SXEB/A,SXE4/A,SXE8/A,SXQ4/A,SXU/A,S1/A
	13310-ZE3-020	.....	1	1	-	4105386	----- SXB7,SXB7/A
2	13310-ZE3-601	CRANKSHAFT COMP. ....	1	1	-	-----	QA,QAB2,QAC2,QAE,QAE2,QAE6,QAG,QAQ,QAQ2,QAP,QAP2,QAQ,QA2,QA26,QDW9,QE,QH,QHB3,QHC,QHE,QHP1,QHQ4,QH2,QKA4,QL2,QME0,QME8,QMH,QMT2,QMX2,QNE,QNE2,QNE6,QNE9,QNR2,QNR6,QN18,QP,QPE2,QT,QTC2,QWH2,QX,QXB,QXC,QXC4,QXC6,QXC9,QXE,QXEB,QXE2,QXE4,QXE6,QXE8,QXQ4,QXU,QX2,Q1
	13310-ZK3-600	.....	1	-	-	-----	3963138 QAB2/A,QAC2/A,QAE2/A,QAE6/A,QAG/A,QAQ2/A,QA2/A,QA26/A,QDW9/A,QE/A,QH/A,QHB3/A,QHB5,QHE/A,QHP1/A,QHQ4/A,QKA4/A,QME0/A,QME8/A,QMH/A,QMT2/A,QNE2/A,QNE9/A,QNR2/A,QNR6/A,QP/A,QT/A,QTC2/A,QWH2/A,QX/A,QXB/A,QXC/A,QXC4/A,QXC6/A,QXC9/A,QXE/A,QXE4/A,QXE6/A,QXE8/A,QXQ4/A,QXU/A,Q1/A
	13310-ZE3-602	.....	1	1	-	3963139	----- QXB7,QXB7/A
							QAQ2/A,QA2/A,QA26/A,QDW9/A,QE/A,QH/A,QHB3/A,QHB5,QHE/A,QHP1/A,QHQ4/A,QKA4/A,QME0/A,QME8/A,QMH/A,QMT2/A,QNE2/A,QNE9/A,QNR2/A,QNR6/A,QP/A,QT/A,QTC2/A,QWH2/A,QX/A,QXB/A,QXC/A,QXC4/A,QXC6/A,QXC9/A,QXE/A,QXE4/A,QXE6/A,QXE8/A,QXQ4/A,QXU/A,Q1/A



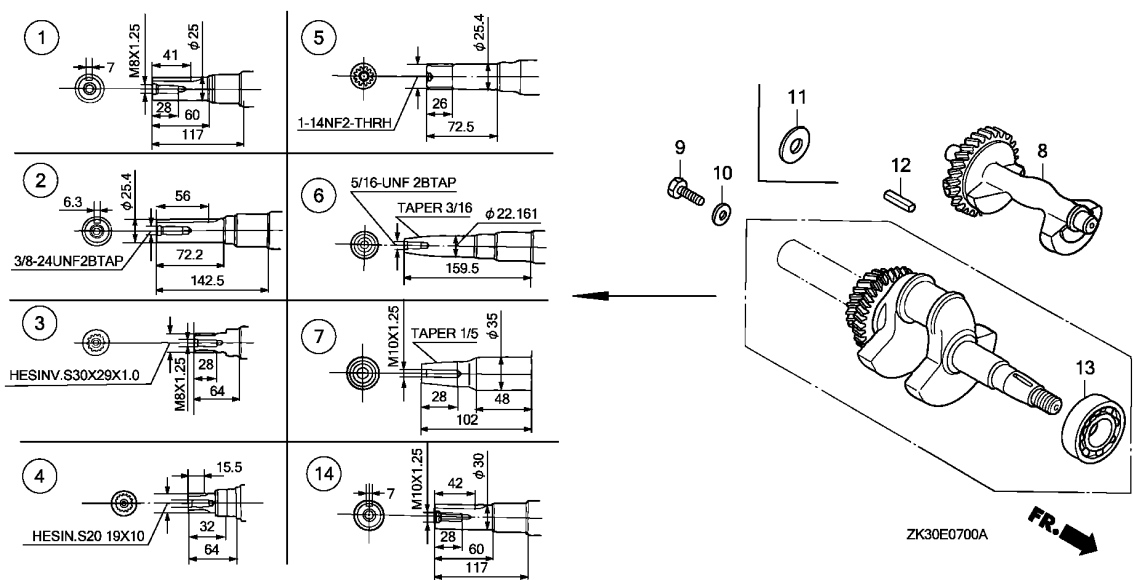

Ref. No.	Part No.	Description	Reqd. QTY			Serial No.	Parts catalogue code
			GX	340K1	(3)		
3	13310-ZE3-611	CRANKSHAFT COMP. ....	1	1	-	-----	BJ, LH, LHB1, LHB3, LHC, LHE, LHQ4, LHW, LJ, LJG, LJS, LKE, LP, LSX, LT, LWD1, LX, LXE, LXE2, LXE4, LXE6, LXE8, LXQ4, LXU, LXZ, LX2, LX26, L1, ZK1
			1	1	-	3969517	LH/A, LHB3/A, LHB5, LHE/A, LHQ4/A, LJ/A, LJG/A, LJS/A, LJS1, LKE/A, LT/A, LWD, LWD1/A, LX/A, LXE/A, LXE2/A, LXE4/A, LXE8/A, LXQ4/A, LXU/A, LX2/A, LX26/A, L1/A, ZK1/A
	13310-ZE3-612	.....	1	1	-	3969518	LH/A, LHB3/A, LHB5, LHE/A, LHQ4/A, LJ/A, LJG/A, LJS/A, LJS1, LKE/A, LT/A, LWD, LWD1/A, LX/A, LXE/A, LXE2/A, LXE4/A, LXE8/A, LXQ4/A, LXU/A, LX2/A, LX26/A, L1/A, ZK1/A
4	13310-ZE3-640	CRANKSHAFT COMP. ....	1	-	-	-----	HA, HAQ, HA2, HA2/A, HH, HX, HX2, HX26, HX26/A
5	13310-ZE3-651	CRANKSHAFT COMP. ....	1	1	-	-----	PKT2, PKT4, PKX4, PX, PXE8, P1
			1	1	-	3971353	PKT2/A, PKT4/A, PKX2, PKX4/A, PX/A, PXA2, PXE8/A, P1/A
	13310-ZE3-652	.....	1	1	-	3971354	PKT2/A, PKT4/A, PKX2, PKX4/A, PX/A, PXA2, PXE8/A, P1/A
6	13310-ZE3-671	CRANKSHAFT COMP. ....	1	1	-	-----	VA, VAA, VAAE, VAD2, VAH1, VAH2, VAW1, VA2, VC2, VDE, VDE2, VD16, VE, VEB6, VH, VHE, VH12, VH22, VMX, VNG, VNG1, VNG2, VS3, VS5, VWA, VWA2, VVC, VVC2, VWE, VWE2, VWS2, VW12, VX, VXA, VXB, VXB2, VXE, VXE8, VXE2, VXE4, VXE6, VXE8, VXG, VXQ4, VXU, VXU1, VX16, VX8, V1
			1	-	-	3970134	VAD2/A, VA2/A, VC2/A, VDE2/A, VH12/A, VH22/A, VMQ, VVC2/A, VWE2/A, VWS2/A, VW12/A, VX/A, VXB/A, VXE/A, VXE8/A, VXE2/A, VXE4/A, VXQ4/A, VXU/A, VXU1/A, VX16/A, VX8/A
	13310-ZK3-670	.....	1	-	1	-----	VSH7, VXB7, VXB7/A, VXE7, VXE7/A
	13310-ZE3-672	.....	1	-	-	-----	VS2, VS3, VS4, VS5, VS6, VS7, VVC, VVE, VVK
			1	-	-	3970135	VAD2/A, VA2/A, VC2/A, VDE2/A, VH12/A, VH22/A, VMQ, VVC2/A, VWE2/A, VWS2/A, VW12/A, VX/A, VXB/A, VXE/A, VXE8/A, VXE2/A, VXE4/A, VXQ4/A, VXU/A, VXU1/A, VX16/A, VX8/A

Ref. No.	Part No.	Description	Reqd. QTY			Serial No.	Parts catalogue code
			(1)	(2)	(3)		
7	13310-ZE3-701	CRANKSHAFT COMP. ....	1	-	-	-----	EDE2,EDE2/A,EDN,EDN2,EDN2/A,EDN5,EDN5/A,EDS,EDS1,EDS1/A,EDS2 EDS2/A,EDS3,EDS5,EDS6,EDS6/A,EDT,EDT/A,EDT1,EDT1/A,EDT2,EDT6 EDT6/A,ED6,ED6/A,ED7,ED8,ED8/A,ED9,ED9/A,EMT,EMT/A,EN,ENT,ENT/A ENT2,EN6,EN6/A,ES,ES1,ES1/A,ES3,ES3/A,ES4,ES4/A,ET,ETS,ETX,VMT VMT/A,VTE2 EDK,EDS4,EDT3,ES2
	13310-ZE3-702	.....	1	-	-	-----	
8	13351-ZE3-010	WEIGHT, BALANCER .....	1	1	1		
9	90003-ZE3-600	BOLT, HEX., 3/8-24UNF (25MM) ..	1	(1)	-	-----	LT,LT/A,QMX2,Q1,Q1/A
	92000-10025-0A	BOLT, HEX., 10X25 .....	1	-	-	-----	YJ
	92101-08025-0A	BOLT, HEX., 8X25 .....	1	(1)	-	-----	LJS,LJS1,SDE,SHT,SJ,SJ/A,SJG,SJG/A,SKE,SKE/A,SKZ,SKZ/A,SME2,SMX2 SMX2/A,STJ,STJ/A,STP,STP/A,STQ,STQ/A,STR,STR/A,S1,S1/A
10	90471-ZE3-000	WASHER, 10.5X40X4 .....	1	(1)	-	-----	LT,LT/A,QMX2,Q1,Q1/A,YJ
11	90534-706-010	WASHER, LOCK, 8MM .....	1	(1)	-	-----	EN,ET,ETS,ETX,LJ,LJ/A,LJG,LJG/A,LJS,LJS1,LWD,SDE,SHT,SJ,SJ/A,SJG SJG/A,SKE,SKE/A,SKZ,SKZ/A,SME2,SMX2,SMX2/A,STJ,STJ/A,STP,STP/A STQ,STQ/A,STR,STR/A,S1,S1/A
12	90741-805-000	KEY, 7X7X33 .....	1	(1)	-	-----	LH,LH/A,LHB3,LHB3/A,LHE,LHE/A,LHQ4,LHQ4/A,LJ,LJ/A,LJG,LJG/A,LJS LJS1,LKE,LKE/A,LP,LX,LX/A,LXE,LXE/A,LXE2,LXE2/A,LXE4,LXE4/A,LXE8 LXE8/A,LXQ4,LXQ4/A,LXU,LXU/A,LX2,LX2/A,LX26,LX26/A,SDE,SE,SE/A,SH SH/A,SHB1,SHB3,SHB3/A,SHE,SHEZ,SHQ4,SHQ4/A,SHT,SJ,SJ/A,SJG,SJG/A SKE,SKE/A,SKZ,SKZ/A,SME2,SMX2,SMX2/A,STJ,STJ/A,STP,STP/A,STQ STQ/A,STR,STR/A,SWX,SWX/A,SX,SX/A,SXB,SXB/A,SXB7,SXB7/A,SXE,SXE/A SXEB,SXEB/A,SXE2,SXE4,SXE4/A,SXE8,SXE8/A,SXP,SXQ4,SXQ4/A,SXU SXU/A,S1,S1/A,YJ
	90741-889-810	KEY, 7X7X33(YELLOW) .....	(1)	(1)	-	-----	EDK,ED8,ED8/A,ED9,ED9/A,EN,ET,ETS,ETX,LH,LH/A,LHB3,LHB3/A,LHE LHE/A,LHQ4,LHQ4/A,LJ,LJ/A,LJG,LJG/A,LJS1,LKE,LKE/A,LP,LX,LX/A,LXE LXE/A,LXE2,LXE2/A,LXE4,LXE4/A,LXE8,LXE8/A,LXQ4,LXQ4/A,LXU,LXU/A LX2,LX2/A,LX26,LX26/A,SDE,SE,SE/A,SH,SH/A,SHB1,SHB3,SHB3/A,SHE SHEZ,SHQ4,SHQ4/A,SHT,SJ,SJ/A,SJG,SJG/A,SKE,SKE/A,SKZ,SKZ/A,SME0 SME0/A,STJ,STJ/A,STP,STP/A,STQ,STQ/A,STR,STR/A,SWX,SWX/A,SX,SX/A SXB,SXB/A,SXB7,SXB7/A,SXE,SXE/A,SXEB,SXEB/A,SXE2,SXE4,SXE4/A,SXE8 SXE8/A,SXP,SXQ4,SXQ4/A,SXU,SXU/A,S1,S1/A,YJ
	90745-ZE2-600	KEY, 6.3X6.3X43 .....	1	(1)	-	-----	HA2/A,HX26/A,QA,QAB2,QAB2/A,QAC2,QAC2/A,QAE,QAE2,QAE2/A,QAE6 QAE6/A,QAG,QAG/A,QA2,QA2/A,QAP,QAPE,QAP2,QAP2/A,QAQ,QA2,QA2/A QA26,QA26/A,QDW9,QDW9/A,QE,QE/A,QH,QH/A,QHB3,QHB3/A,QHB5,QHC,QHE QHE/A,QHP1,QHP1/A,QHQ4,QHQ4/A,QH2,QKA4,QKA4/A,QL2,QMH,QMH/A,QMT2 QMT2/A,QMX2,QNE,QNE2,QNE2/A,QNE6,QNE9,QNE9/A,QNR2,QNR2/A,QNR6 QNR6/A,QN18,QP,QP/A,QPE2,QT,QT/A,QWH2,QWH2/A,QX,QX/A,QXB,QXB/A QXB7,QXB7/A,QXC,QXC/A,QXC4,QXC4/A,QXC6,QXC6/A,QXC9,QXC9/A,QXE QXE/A,QXEB,QXE2,QXE4,QXE4/A,QXE6,QXE6/A,QXE8,QXE8/A,QXQ4,QXQ4/A QXU,QXU/A,QX2,Q1,Q1/A
13	96100-62070-00	BEARING, RADIAL BALL, 6207 ..	1	1	1		
14	13310-ZE3-811	CRANKSHAFT COMP. ....	1	-	-	-----	YJ



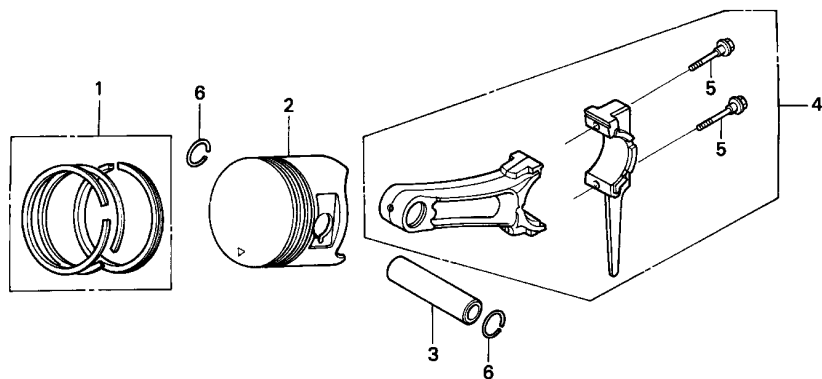

ZK30-E0800A

Ref. No.	L.O.N.	(Relative ref. Number) Description	F.R.T.
2		(1,3,4)	
1111R1		PISTON AND/OR RING SET AND/OR BEARING AND/OR ROD ..... INCLUDES: Inspection/ Measurement/Cleaning	1.2

Ref. No.	Part No.	Description	Reqd. QTY GX 340K1 (1) (2) (3)	Serial No.	Parts catalogue code	
1	13010-ZE3-003	RING SET, PISTON (STD.) (NIPPON)	1 1 -	-----	BJ, EDE2, EDE2/A, EDN, EDN2, EDN2/A, EDN5, EDS, EDS1, EDS2, EDS2/A, EDS3, EDS5, EDS6, EDS6/A, EDT, EDT/A, EDT1, EDT2, EDT6, EDT6/A, ED6, ED6/A, ED7, ED8, ED9, EMT, EN, ENT, ENT/A, ENT2, EN6, EN6/A, ES, ES1, ES3, ES4, ET, ETS, ETX, HA, HAQ, HA2, HA2/A, HH, HX, HX2, HX26, HX26/A, LH, LHB1, LHB3, LHC, LHE, LHQ4, LHQ4/A, LHW, LJ, LJG, LJS, LKE, LKE/A, LP, LSX, LT, LWD1, LX, LXE, LXE2, LXE2/A, LX4, LX4/A, LX6, LX6/A, LX8, LX8/A, LXQ4, LXQ4/A, LXU, LXU/A, LXZ, LXZ/A, LX26, LX26/A, L1, PKT2, PKT2/A, PKT4, PKT4/A, PKX2, PKX4, PKX4/A, PX, PXA2, PXE8, PXE8/A, P1, QA, QAB2, QAB2/A, QAC2, QAC2/A, QAE, QAE2, QAE2/A, QAE6, QAE6/A, QAG, QAG/A, QAH2, QAH2/A, QAP, QAPE, QAP2, QAP2/A, QAQ, QA2, QA2/A, QA26, QA26/A, QDW9, QDW9/A, QE, QE/A, QH, QHB3, QHC, QHE, QHE/A, QHP1, QHQ4, QHQ4/A, QH2, QKA4, QKA4/A, QL2, QME0, QME0/A, QME8, QME8/A, QMH, QMT2, QMT2/A, QMX2, QNE, QNE2, QNE2/A, QNE6, QNE9, QNE9/A, QNR2, QNR2/A, QNR6, QNR6/A, QN18, QP, QPE2, QT, QT/A, QTC2, QTC2/A, QWH2, QWH2/A, QX, QXB, QXB/A, QXB7, QXB7/A, QXC, QXC4, QXC4/A, QXC6, QXC6/A, QXC9, QXC9/A, QXE, QXEB, QXE2, QXE4, QXE4/A, QXE6, QXE6/A, QXE8, QXE8/A, QXQ4, QXQ4/A, QXU, QXU/A, QX2, Q1, SDE, SE, SE/A, SH, SHB1, SHB3, SHB3/A, SHE, SHEZ, SHQ4, SHQ4/A, SHT, SJ, SJG, SKE, SKZ, SME0, SME0/A, SME2, SMX2, SMX2/A, STJ, STP, STQ, STR, SWX, SWX/A, SX, SXB, SXB/A, SXB7, SXB7/A, SXE, SXEB, SXEB/A, SXE2, SXE4, SXE4/A, SXE8, SXE8/A, SXP, SXQ4, SXQ4/A, SXU, SXU/A, S1, VA, VAA, VAAE, VAD2, VAD2/A, VAH1, VAH2, VAW1, VA2, VA2/A, VC2, VC2/A, VDE, VDE2, VDE2/A, VD16, VE, VEB6, VH, VHE, VH12, VH12/A, VH22, VH22/A, VMT, VMX, VNG, VNG1, VNG2, VSH7, VTE2, VVA, VVA2, VVC, VVC2, VVC2/A, VVE, VVE2, VVE2/A, VWS2, VWS2/A, VW12, VW12/A, VX, VXA, VXB, VXB/A, VXB2, VXB7, VXB7/A, VXE, VXEB, VXEB/A, VXE2, VXE4, VXE6, VXE7, VXE7/A, VXE8, VXE8/A, VXG, VXQ4, VXQ4/A, VXU, VXU1, VX16, VX16/A, VX8, VX8/A, V1, YJ, ZK1, ZK1/A	





Ref. No.	Part No.	Description	Reqd. QTY			Serial No.	Parts catalogue code
			(1)	(2)	(3)		
(1)	13010-ZE3-003	RING SET, PISTON (STD.) (NIPPON)	1	1	-	4099047	EDK,EDN5/A,EDS1/A,EDS4,EDT1/A,ED8/A,ED9/A,EMT/A,ES1/A,ES3/A,ES4/A LH/A,LHB3/A,LHB5,LHE/A,LJ/A,LJG/A,LJS/A,LJS1,LT/A,LWD,LWD1/A,LX/A LXE/A,L1/A,PX/A,P1/A,QH/A,QHB3/A,QHB5,QHP1/A,QMH/A,QP/A,QX/A QXC/A,QXE/A,Q1/A,SH/A,SJ/A,SJG/A,SKE/A,SKZ/A,STJ/A,STP/A,STQ/A STR/A,SX/A,SXE/A,S1/A,VMQ,VMT/A,VS3,VS4,VS5,VS6,VX/A,VXE/A,VXEB/A VXK,VXU/A,VXU1/A
			-	-	1		
	13010-ZE3-005	RING SET, PISTON (STD.) (TEIKOKU)	1	1	-		BJ,EDE2,EDE2/A,EDN,EDN2,EDN2/A,EDN5,EDS,EDS1,EDS2,EDS2/A,EDS3 EDS5,EDS6,EDS6/A,EDT,EDT/A,EDT1,EDT2,EDT6,EDT6/A,ED6,ED6/A,ED7 ED8,ED9,EMT,EN,ENT,ENT/A,ENT2,EN6,EN6/A,ES,ES1,ES3,ES4,ET,ETS,ETX HA,HAQ,HA2,HA2/A,HH,HX,HX2,HX26,HX26/A,LH,LHB1,LHB3,LHC,LHE,LHQ4 LHQ4/A,LHW,LJ,LJG,LJS,LKE,LKE/A,LP,LSX,LT,LWD1,LX,LXE,LXE2,LXE2/A LXE4,LXE4/A,LXE6,LXE8,LXE8/A,LXQ4,LXQ4/A,LXU,LXU/A,LXZ,LX2,LX2/A LX26,LX26/A,L1,PKT2,PKT2/A,PKT4,PKT4/A,PKX2,PKX4,PKX4/A,PX,PXA2 PX8,PXE8/A,P1,QA,QAB2,QAB2/A,QAC2,QAC2/A,QAE,QAE2,QAE2/A,QAE6 QAE6/A,QAG,QAG/A,QA2,QA2/A,QAP,QAPE,QAP2,QAP2/A,QAQ,QA2,QA2/A QA26,QA26/A,QDW9,QDW9/A,QE,QE/A,QH,QHB3,QHC,QHE,QHE/A,QHP1,QHQ4 QHQ4/A,QH2,QKA4,QKA4/A,QL2,QMEO,QMEO/A,QME8,QME8/A,QMH,QMT2 QMT2/A,QMX2,QNE,QNE2,QNE2/A,QNE6,QNE9,QNE9/A,QNR2,QNR2/A,QNR6 QNR6/A,QN18,QP,QPE2,QT,QT/A,QTC2,QTC2/A,QWH2,QWH2/A,QX,QXB,QXB/A QXB7,QXB7/A,QXC,QXC4,QXC4/A,QXC6,QXC6/A,QXC9,QXC9/A,QXE,QXE2,QXE2 QXE4,QXE4/A,QXE6,QXE6/A,QXE8,QXE8/A,QXQ4,QXQ4/A,QXU,QXU/A,QX2,Q1 SDE,SE,SE/A,SH,SHB1,SHB3,SHB3/A,SHE,SHEZ,SHQ4,SHQ4/A,SHT,SJ,SJG SKE,SKZ,SME0,SME0/A,SME2,SMX2,SMX2/A,STJ,STP,STQ,STR,SWX,SWX/A,SX SXB,SXB/A,SXB7,SXB7/A,SXE,SXEB,SXEB/A,SXE2,SXE4,SXE4/A,SXE8 SXE8/A,SXP,SXQ4,SXQ4/A,SXU,SXU/A,S1,VA,VAA,VAAE,VAD2,VAD2/A,VAH1 VAH2,VAW1,VA2,VA2/A,VC2,VC2/A,VDE,VDE2,VDE2/A,VD16,VE,VEB6,VH,VHE VH12,VH12/A,VH22,VH22/A,VMT,VMX,VNG,VNG1,VNG2,VSH7,VTE2,VWA,VWA2 VWC,VWC2,VWC2/A,VWE,VWE2,VWE2/A,VWS2,VWS2/A,VW12,VW12/A,VX,VXA VXB,VXB/A,VXB7,VXB7/A,VXE,VXEB,VXE2,VXE2/A,VXE4,VXE6,VXE7 VXE7/A,VXE8,VXE8/A,VXG,VXQ4,VXQ4/A,VXU,VXU1,VX16,VX16/A,VX8,VX8/A V1,YJ,ZK1,ZK1/A
			1	1	-	4099047	EDK,EDN5/A,EDS1/A,EDS4,EDT1/A,ED8/A,ED9/A,EMT/A,ES1/A,ES3/A,ES4/A LH/A,LHB3/A,LHB5,LHE/A,LJ/A,LJG/A,LJS/A,LJS1,LT/A,LWD,LWD1/A,LX/A LXE/A,L1/A,PX/A,P1/A,QH/A,QHB3/A,QHB5,QHP1/A,QMH/A,QP/A,QX/A QXC/A,QXE/A,Q1/A,SH/A,SJ/A,SJG/A,SKE/A,SKZ/A,STJ/A,STP/A,STQ/A STR/A,SX/A,SXE/A,S1/A,VMQ,VMT/A,VS3,VS4,VS5,VS6,VX/A,VXE/A,VXEB/A VXK,VXU/A,VXU1/A
			-	-	1		



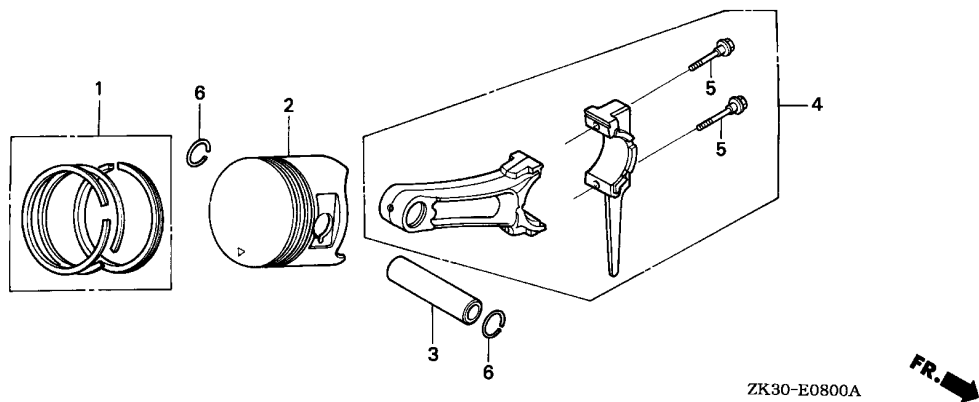

2

Ref. No.	Part No.	Description	Reqd. QTY GX 340K1 (1) (2) (3)	Serial No.	Parts catalogue code
(1)	13011-ZE3-003	RING SET, PISTON (0.25) (NIPPON)	(1) (1) -	-----	BJ, EDE2, EDE2/A, EDN, EDN2, EDN2/A, EDN5, EDS, EDS1, EDS2, EDS2/A, EDS3, EDS5, EDS6, EDS6/A, EDT, EDT/A, EDT1, EDT2, EDT6, EDT6/A, ED6, ED6/A, ED7, ED8, ED9, EMT, EN, ENT, ENT/A, ENT2, EN6, EN6/A, ES, ES1, ES3, ES4, ET, ETS, ETX, HA, HAQ, HA2, HA2/A, HH, HX, HX2, HX26, HX26/A, LH, LHB1, LHB3, LHC, LHE, LHQ4, LHQ4/A, LHW, LJ, LJG, LJS, LKE, LKE/A, LP, LSX, LT, LWD1, LX, LXE, LXE2, LXE2/A, LXE4, LXE4/A, LXE6, LXE8, LXE8/A, LXQ4, LXQ4/A, LXU, LXU/A, LXZ, LX2, LX2/A, LX26, LX26/A, L1, PKT2, PKT2/A, PKT4, PKT4/A, PKX2, PKX4, PKX4/A, PX, PXA2, PXE8, PXE8/A, P1, QA, QAB2, QAB2/A, QAC2, QAC2/A, QAE, QAE2, QAE2/A, QAE6, QAE6/A, QAG, QAG/A, QAH2, QAH2/A, QAP, QAPE, QAP2, QAP2/A, QAQ, QA2, QA2/A, QA26, QA26/A, QDW9, QDW9/A, QE, QE/A, QH, QHB3, QHC, QHE, QHE/A, QHP1, QHQ4, QHQ4/A, QH2, QKA4, QKA4/A, QL2, QME0, QME0/A, QME8, QME8/A, QMH, QMT2, QMT2/A, QMX2, QNE, QNE2, QNE2/A, QNE6, QNE9, QNE9/A, QNR2, QNR2/A, QNR6, QNR6/A, QN18, QP, QPE2, QT, QT/A, QTC2, QTC2/A, QWH2, QWH2/A, QX, QXB, QXB/A, QXB7, QXB7/A, QXC, QXC4, QXC4/A, QXC6, QXC6/A, QXC9, QXC9/A, QXE, QXEB, QXE2, QXE4, QXE4/A, QXE6, QXE6/A, QXE8, QXE8/A, QXQ4, QXQ4/A, QXU, QXU/A, QX2, Q1, SDE, SE, SE/A, SH, SHB1, SHB3, SHB3/A, SHE, SHEZ, SHQ4, SHQ4/A, SHT, SJ, SJG, SKE, SKZ, SME0, SME0/A, SME2, SMX2, SMX2/A, STJ, STP, STQ, STR, SWX, SWX/A, SX, SXB, SXB/A, SXB7, SXB7/A, SXE, SXEB, SXEB/A, SXE2, SXE4, SXE4/A, SXE8, SXE8/A, SXP, SXQ4, SXQ4/A, SXU, SXU/A, S1, VA, VAA, VAAE, VAD2, VAD2/A, VAH1, VAH2, VAW1, VA2, VA2/A, VC2, VC2/A, VDE, VDE2, VDE2/A, VD16, VE, VEB6, VH, VHE, VH12, VH12/A, VH22, VH22/A, VMT, VMX, VNG, VNG1, VNG2, VSH7, VTE2, VVA, VVA2, VVC, VVC2, VVC2/A, VVE, VVE2, VVE2/A, VWS2, VWS2/A, VW12, VW12/A, VX, VXA, VXB, VXB/A, VXB2, VXB7, VXB7/A, VXE, VXEB, VXEB/A, VXE2, VXE4, VXE6, VXE7, VXE7/A, VXE8, VXE8/A, VXG, VXQ4, VXQ4/A, VXU, VXU1, VX16, VX16/A, VX8, VX8/A, V1, YJ, ZK1, ZK1/A

Ref. No.	Part No.	Description	Reqd. QTY			Serial No.	Parts catalogue code
			(1)	(2)	(3)		
(1)	13011-ZE3-003	RING SET, PISTON (0.25) (NIPPON)	(1)	(1)	-	4099047	EDK,EDN5/A,EDS1/A,EDS4,EDT1/A,ED8/A,ED9/A,EMT/A,ES1/A,ES3/A,ES4/A LH/A,LHB3/A,LHB5,LHE/A,LJ/A,LJG/A,LJS/A,LJS1,LT/A,LWD,LWD1/A,LX/A LXE/A,L1/A,PX/A,P1/A,QH/A,QHB3/A,QHB5,QHP1/A,QMH/A,QP/A,QX/A QXC/A,QXE/A,Q1/A,SH/A,SJ/A,SJG/A,SKE/A,SKZ/A,STJ/A,STP/A,STQ/A STR/A,SX/A,SXE/A,S1/A,VMQ,VMT/A,VS3,VS4,VS5,VS6,VX/A,VXE/A,VXEB/A VXK,VXU/A,VXU1/A
			-	-	(1)		
	13011-ZE3-005	RING SET, PISTON (0.25) (TEIKOKU)	(1)	(1)	-		BJ,EDE2,EDE2/A,EDN,EDN2,EDN2/A,EDN5,EDS,EDS1,EDS2,EDS2/A,EDS3 EDS5,EDS6,EDS6/A,EDT,EDT/A,EDT1,EDT2,EDT6,EDT6/A,ED6,ED6/A,ED7 ED8,ED9,EMT,EN,ENT,ENT/A,ENT2,EN6,EN6/A,ES,ES1,ES3,ES4,ET,ETS,ETX HA,HAQ,HA2,HA2/A,HH,HX,HX2,HX26,HX26/A,LH,LHB1,LHB3,LHC,LHE,LHQ4 LHQ4/A,LHW,LJ,LJG,LJS,LKE,LKE/A,LP,LSX,LT,LWD1,LX,LXE,LXE2,LXE2/A LXE4,LXE4/A,LXE6,LXE8,LXE8/A,LXQ4,LXQ4/A,LXU,LXU/A,LXZ,LX2,LX2/A LX26,LX26/A,L1,PKT2,PKT2/A,PKT4,PKT4/A,PKX2,PKX4,PKX4/A,PX,PXA2 PX8,PXE8/A,P1,QA,QAB2,QAB2/A,QAC2,QAC2/A,QAE,QAE2,QAE2/A,QAE6 QAE6/A,QAG,QAG/A,QA2,QA2/A,QAP,QAPE,QAP2,QAP2/A,QAQ,QA2,QA2/A QA26,QA26/A,QDW9,QDW9/A,QE,QE/A,QH,QHB3,QHC,QHE,QHE/A,QHP1,QHQ4 QHQ4/A,QH2,QKA4,QKA4/A,QL2,QMEO,QMEO/A,QME8,QME8/A,QMH,QMT2 QMT2/A,QMX2,QNE,QNE2,QNE2/A,QNE6,QNE9,QNE9/A,QNR2,QNR2/A,QNR6 QNR6/A,QN18,QP,QPE2,QT,QT/A,QTC2,QTC2/A,QWH2,QWH2/A,QX,QXB,QXB/A QXB7,QXB7/A,QXC,QXC4,QXC4/A,QXC6,QXC6/A,QXC9,QXC9/A,QXE,QXE2,QXE2 QXE4,QXE4/A,QXE6,QXE6/A,QXE8,QXE8/A,QXQ4,QXQ4/A,QXU,QXU/A,QX2,Q1 SDE,SE,SE/A,SH,SHB1,SHB3,SHB3/A,SHE,SHEZ,SHQ4,SHQ4/A,SHT,SJ,SJG SKE,SKZ,SME0,SME0/A,SME2,SMX2,SMX2/A,STJ,STP,STQ,STR,SWX,SWX/A,SX SXB,SXB/A,SXB7,SXB7/A,SXE,SXEB,SXEB/A,SXE2,SXE4,SXE4/A,SXE8 SXE8/A,SXP,SXQ4,SXQ4/A,SXU,SXU/A,S1,VA,VAA,VAE,VAE2,VAE2/A,VAH1 VAH2,VAW1,VA2,VA2/A,VC2,VC2/A,VDE,VDE2,VDE2/A,VD16,VE,VEB6,VH,VHE VH12,VH12/A,VH22,VH22/A,VMT,VMX,VNG,VNG1,VNG2,VSH7,VTE2,VVA,VWA2 VWC,VWC2,VWC2/A,VWE,VWE2,VWE2/A,VWS2,VWS2/A,VW12,VW12/A,VX,VXA VXB,VXB/A,VXB7,VXB7/A,VXE,VXEB,VXE2,VXE2/A,VXE4,VXE6,VXE7 VXE7/A,VXE8,VXE8/A,VXG,VXQ4,VXQ4/A,VXU,VXU1,VX16,VX16/A,VX8,VX8/A V1,YJ,ZK1,ZK1/A
			(1)	(1)	-	4099047	EDK,EDN5/A,EDS1/A,EDS4,EDT1/A,ED8/A,ED9/A,EMT/A,ES1/A,ES3/A,ES4/A LH/A,LHB3/A,LHB5,LHE/A,LJ/A,LJG/A,LJS/A,LJS1,LT/A,LWD,LWD1/A,LX/A LXE/A,L1/A,PX/A,P1/A,QH/A,QHB3/A,QHB5,QHP1/A,QMH/A,QP/A,QX/A QXC/A,QXE/A,Q1/A,SH/A,SJ/A,SJG/A,SKE/A,SKZ/A,STJ/A,STP/A,STQ/A STR/A,SX/A,SXE/A,S1/A,VMQ,VMT/A,VS3,VS4,VS5,VS6,VX/A,VXE/A,VXEB/A VXK,VXU/A,VXU1/A
			-	-	(1)		



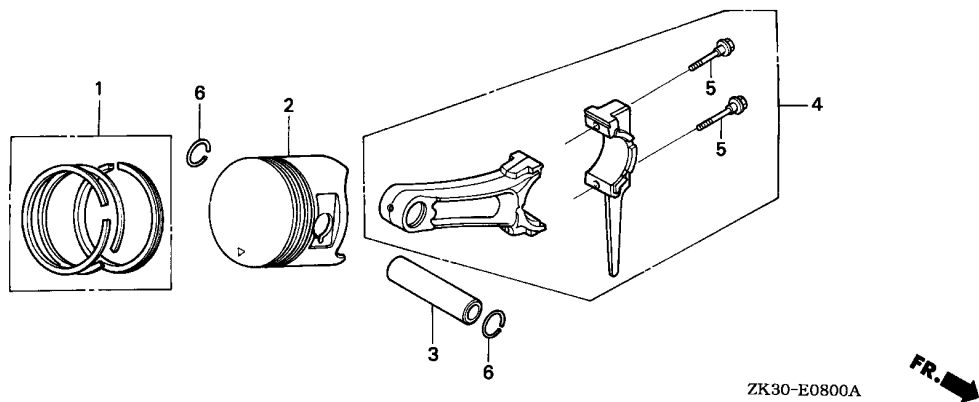

Ref. No.	Part No.	Description	Reqd. QTY GX 340K1 (1) (2) (3)	Serial No.	Parts catalogue code
(1)	13012-ZE3-003	RING SET, PISTON (0.50) (NIPPON)	(1) (1) -	-----	BJ, EDE2, EDE2/A, EDN, EDN2, EDN2/A, EDN5, EDS, EDS1, EDS2, EDS2/A, EDS3, EDS5, EDS6, EDS6/A, EDT, EDT/A, EDT1, EDT2, EDT6, EDT6/A, ED6, ED6/A, ED7, ED8, ED9, EMT, EN, ENT, ENT/A, ENT2, EN6, EN6/A, ES, ES1, ES3, ES4, ET, ETS, ETX, HA, HAQ, HA2, HA2/A, HH, HX, HX2, HX26, HX26/A, LH, LHB1, LHB3, LHC, LHE, LHQ4, LHQ4/A, LHW, LJ, LJG, LJS, LKE, LKE/A, LP, LSX, LT, LWD1, LX, LXE, LXE2, LXE2/A, LXE4, LXE4/A, LXE6, LXE8, LXE8/A, LXQ4, LXQ4/A, LXU, LXU/A, LXZ, LX2, LX2/A, LX26, LX26/A, L1, PKT2, PKT2/A, PKT4, PKT4/A, PKX2, PKX4, PKX4/A, PX, PXA2, PXE8, PXE8/A, P1, QA, QAB2, QAB2/A, QAC2, QAC2/A, QAE, QAE2, QAE2/A, QAE6, QAE6/A, QAG, QAG/A, QAH2, QAH2/A, QAP, QAPE, QAP2, QAP2/A, QAQ, QA2, QA2/A, QA26, QA26/A, QDW9, QDW9/A, QE, QE/A, QH, QHB3, QHC, QHE, QHE/A, QHP1, QHQ4, QHQ4/A, QH2, QKA4, QKA4/A, QL2, QME0, QME0/A, QME8, QME8/A, QMH, QMT2, QMT2/A, QMX2, QNE, QNE2, QNE2/A, QNE6, QNE9, QNE9/A, QNR2, QNR2/A, QNR6, QNR6/A, QN18, QP, QPE2, QT, QT/A, QTC2, QTC2/A, QWH2, QWH2/A, QX, QXB, QXB/A, QXB7, QXB7/A, QXC, QXC4, QXC4/A, QXC6, QXC6/A, QXC9, QXC9/A, QXE, QXEB, QXE2, QXE4, QXE4/A, QXE6, QXE6/A, QXE8, QXE8/A, QXQ4, QXQ4/A, QXU, QXU/A, QX2, Q1, SDE, SE, SE/A, SH, SHB1, SHB3, SHB3/A, SHE, SHEZ, SHQ4, SHQ4/A, SHT, SJ, SJG, SKE, SKZ, SME0, SME0/A, SME2, SMX2, SMX2/A, STJ, STP, STQ, STR, SWX, SWX/A, SX, SXB, SXB/A, SXB7, SXB7/A, SXE, SXEB, SXEB/A, SXE2, SXE4, SXE4/A, SXE8, SXE8/A, SXP, SXQ4, SXQ4/A, SXU, SXU/A, S1, VA, VAA, VAAE, VAD2, VAD2/A, VAH1, VAH2, VAW1, VA2, VA2/A, VC2, VC2/A, VDE, VDE2, VDE2/A, VD16, VE, VEB6, VH, VHE, VH12, VH12/A, VH22, VH22/A, VMT, VMX, VNG, VNG1, VNG2, VSH7, VTE2, VVA, VVA2, VVC, VVC2, VVC2/A, VVE, VVE2, VVE2/A, VWS2, VWS2/A, VW12, VW12/A, VX, VXA, VXB, VXB/A, VXB2, VXB7, VXB7/A, VXE, VXEB, VXEB/A, VXE2, VXE4, VXE6, VXE7, VXE7/A, VXE8, VXE8/A, VXG, VXQ4, VXQ4/A, VXU, VXU1, VX16, VX16/A, VX8, VX8/A, V1, YJ, ZK1, ZK1/A



Ref. No.	Part No.	Description	Reqd. QTY			Serial No.	Parts catalogue code
			(1)	(2)	(3)		
(1)	13012-ZE3-003	RING SET, PISTON (0.50) (NIPPON)	(1)	(1)	-	4099047	EDK,EDN5/A,EDS1/A,EDS4,EDT1/A,ED8/A,ED9/A,EMT/A,ES1/A,ES3/A,ES4/A LH/A,LHB3/A,LHB5,LHE/A,LJ/A,LJG/A,LJS/A,LJS1,LT/A,LWD,LWD1/A,LX/A LXE/A,L1/A,PX/A,P1/A,QH/A,QHB3/A,QHB5,QHP1/A,QMH/A,QP/A,QX/A QXC/A,QXE/A,Q1/A,SH/A,SJ/A,SJG/A,SKE/A,SKZ/A,STJ/A,STP/A,STQ/A STR/A,SX/A,SXE/A,S1/A,VMQ,VMT/A,VS3,VS4,VS5,VS6,VX/A,VXE/A,VXEB/A VXK,VXU/A,VXU1/A
			-	-	(1)		
	13012-ZE3-005	RING SET, PISTON (0.50) (TEIKOKU)	(1)	(1)	-		BJ,EDE2,EDE2/A,EDN,EDN2,EDN2/A,EDN5,EDS,EDS1,EDS2,EDS2/A,EDS3 EDS5,EDS6,EDS6/A,EDT,EDT/A,EDT1,EDT2,EDT6,EDT6/A,ED6,ED6/A,ED7 ED8,ED9,EMT,EN,ENT,ENT/A,ENT2,EN6,EN6/A,ES,ES1,ES3,ES4,ET,ETS,ETX HA,HAQ,HA2,HA2/A,HH,HX,HX2,HX26,HX26/A,LH,LHB1,LHB3,LHC,LHE,LHQ4 LHQ4/A,LHW,LJ,LJG,LJS,LKE,LKE/A,LP,LSX,LT,LWD1,LX,LXE,LXE2,LXE2/A LXE4,LXE4/A,LXE6,LXE8,LXE8/A,LXQ4,LXQ4/A,LXU,LXU/A,LXZ,LX2,LX2/A LX26,LX26/A,L1,PKT2,PKT2/A,PKT4,PKT4/A,PKX2,PKX4,PKX4/A,PX,PXA2 PX8,PXE8/A,P1,QA,QAB2,QAB2/A,QAC2,QAC2/A,QAE,QAE2,QAE2/A,QAE6 QAE6/A,QAG,QAG/A,QA2,QA2/A,QAP,QAPE,QAP2,QAP2/A,QAQ,QA2,QA2/A QA26,QA26/A,QDW9,QDW9/A,QE,QE/A,QH,QHB3,QHC,QHE,QHE/A,QHP1,QHQ4 QHQ4/A,QH2,QKA4,QKA4/A,QL2,QMEO,QMEO/A,QME8,QME8/A,QMH,QMT2 QMT2/A,QMX2,QNE,QNE2,QNE2/A,QNE6,QNE9,QNE9/A,QNR2,QNR2/A,QNR6 QNR6/A,QN18,QP,QPE2,QT,QT/A,QTC2,QTC2/A,QWH2,QWH2/A,QX,QXB,QXB/A QXB7,QXB7/A,QXC,QXC4,QXC4/A,QXC6,QXC6/A,QXC9,QXC9/A,QXE,QXE2,QXE2 QXE4,QXE4/A,QXE6,QXE6/A,QXE8,QXE8/A,QXQ4,QXQ4/A,QXU,QXU/A,QX2,Q1 SDE,SE,SE/A,SH,SHB1,SHB3,SHB3/A,SHE,SHEZ,SHQ4,SHQ4/A,SHT,SJ,SJG SKE,SKZ,SME0,SME0/A,SME2,SMX2,SMX2/A,STJ,STP,STQ,STR,SWX,SWX/A,SX SXB,SXB/A,SXB7,SXB7/A,SXE,SXEB,SXEB/A,SXE2,SXE4,SXE4/A,SXE8 SXE8/A,SXP,SXQ4,SXQ4/A,SXU,SXU/A,S1,VA,VAA,VAE,VAE2,VAE2/A,VAH1 VAH2,VAW1,VA2,VA2/A,VC2,VC2/A,VDE,VDE2,VDE2/A,VD16,VE,VEB6,VH,VHE VH12,VH12/A,VH22,VH22/A,VMT,VMX,VNG,VNG1,VNG2,VSH7,VTE2,VWA,VWA2 VWC,VWC2,VWC2/A,VWE,VWE2,VWE2/A,VWS2,VWS2/A,VW12,VW12/A,VX,VXA VXB,VXB/A,VXB7,VXB7/A,VXE,VXEB,VXE2,VXE2/A,VXE4,VXE6,VXE7 VXE7/A,VXE8,VXE8/A,VXG,VXQ4,VXQ4/A,VXU,VXU1,VX16,VX16/A,VX8,VX8/A V1,YJ,ZK1,ZK1/A
			(1)	(1)	-	4099047	EDK,EDN5/A,EDS1/A,EDS4,EDT1/A,ED8/A,ED9/A,EMT/A,ES1/A,ES3/A,ES4/A LH/A,LHB3/A,LHB5,LHE/A,LJ/A,LJG/A,LJS/A,LJS1,LT/A,LWD,LWD1/A,LX/A LXE/A,L1/A,PX/A,P1/A,QH/A,QHB3/A,QHB5,QHP1/A,QMH/A,QP/A,QX/A QXC/A,QXE/A,Q1/A,SH/A,SJ/A,SJG/A,SKE/A,SKZ/A,STJ/A,STP/A,STQ/A STR/A,SX/A,SXE/A,S1/A,VMQ,VMT/A,VS3,VS4,VS5,VS6,VX/A,VXE/A,VXEB/A VXK,VXU/A,VXU1/A
			-	-	(1)		



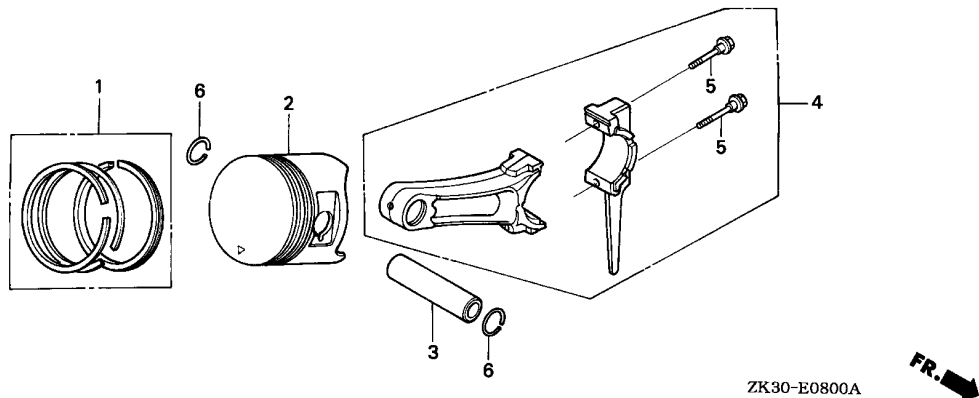

Ref. No.	Part No.	Description	Reqd. QTY GX 340K1 (1) (2) (3)	Serial No.	Parts catalogue code	
(1)	13013-ZE3-003	RING SET, PISTON (0.75) (NIPPON)	(1) (1) -	-----	BJ, EDE2, EDE2/A, EDN, EDN2, EDN2/A, EDN5, EDS, EDS1, EDS2, EDS2/A, EDS3, EDS5, EDS6, EDS6/A, EDT, EDT/A, EDT1, EDT2, EDT6, EDT6/A, ED6, ED6/A, ED7, ED8, ED9, EMT, EN, ENT, ENT/A, ENT2, EN6, EN6/A, ES, ES1, ES3, ES4, ET, ETS, ETX, HA, HAQ, HA2, HA2/A, HH, HX, HX2, HX26, HX26/A, LH, LHB1, LHB3, LHC, LHE, LHQ4, LHQ4/A, LHW, LJ, LJG, LJS, LKE, LKE/A, LP, LSX, LT, LWD1, LX, LXE, LXE2, LXE2/A, LXE4, LXE4/A, LXE6, LXE8, LXE8/A, LXQ4, LXQ4/A, LXU, LXU/A, LXZ, LX2, LX2/A, LX26, LX26/A, L1, PKT2, PKT2/A, PKT4, PKT4/A, PKX2, PKX4, PKX4/A, PX, PXA2, PXE8, PXE8/A, P1, QA, QAB2, QAB2/A, QAC2, QAC2/A, QAE, QAE2, QAE2/A, QAE6, QAE6/A, QAG, QAG/A, QAH2, QAH2/A, QAP, QAPE, QAP2, QAP2/A, QAQ, QA2, QA2/A, QA26, QA26/A, QDW9, QDW9/A, QE, QE/A, QH, QHB3, QHC, QHE, QHE/A, QHP1, QHQ4, QHQ4/A, QH2, QKA4, QKA4/A, QL2, QME0, QME0/A, QME8, QME8/A, QMH, QMT2, QMT2/A, QMX2, QNE, QNE2, QNE2/A, QNE6, QNE9, QNE9/A, QNR2, QNR2/A, QNR6, QNR6/A, QN18, QP, QPE2, QT, QT/A, QTC2, QTC2/A, QWH2, QWH2/A, QX, QXB, QXB/A, QXB7, QXB7/A, QXC, QXC4, QXC4/A, QXC6, QXC6/A, QXC9, QXC9/A, QXE, QXEB, QXE2, QXE4, QXE4/A, QXE6, QXE6/A, QXE8, QXE8/A, QXQ4, QXQ4/A, QXU, QXU/A, QX2, Q1, SDE, SE, SE/A, SH, SHB1, SHB3, SHB3/A, SHE, SHEZ, SHQ4, SHQ4/A, SHT, SJ, SJG, SKE, SKZ, SME0, SME0/A, SME2, SMX2, SMX2/A, STJ, STP, STQ, STR, SWX, SWX/A, SX, SXB, SXB/A, SXB7, SXB7/A, SXE, SXEB, SXEB/A, SXE2, SXE4, SXE4/A, SXE8, SXE8/A, SXP, SXQ4, SXQ4/A, SXU, SXU/A, S1, VA, VAA, VAAE, VAD2, VAD2/A, VAH1, VAH2, VAW1, VA2, VA2/A, VC2, VC2/A, VDE, VDE2, VDE2/A, VD16, VE, VEB6, VH, VHE, VH12, VH12/A, VH22, VH22/A, VMT, VMX, VNG, VNG1, VNG2, VSH7, VTE2, VVA, VVA2, VVC, VVC2, VVC2/A, VVE, VVE2, VVE2/A, VWS2, VWS2/A, VW12, VW12/A, VX, VXA, VXB, VXB/A, VXB2, VXB7, VXB7/A, VXE, VXEB, VXEB/A, VXE2, VXE4, VXE6, VXE7, VXE7/A, VXE8, VXE8/A, VXG, VXQ4, VXQ4/A, VXU, VXU1, VX16, VX16/A, VX8, VX8/A, V1, YJ, ZK1, ZK1/A	

Ref. No.	Part No.	Description	Reqd. QTY			Serial No.	Parts catalogue code
			GX 340K1 (1)	(2)	(3)		
(1)	13013-ZE3-003	RING SET, PISTON (0.75) (NIPPON)	(1)	(1)	-	4099047	EDK,EDN5/A,EDS1/A,EDS4,EDT1/A,ED8/A,ED9/A,EMT/A,ES1/A,ES3/A,ES4/A LH/A,LHB3/A,LHB5,LHE/A,LJ/A,LJG/A,LJS/A,LJS1,LT/A,LWD,LWD1/A,LX/A LXE/A,L1/A,PX/A,P1/A,QH/A,QHB3/A,QHB5,QHP1/A,QMH/A,QP/A,QX/A QXC/A,QXE/A,Q1/A,SH/A,SJ/A,SJG/A,SKE/A,SKZ/A,STJ/A,STP/A,STQ/A STR/A,SX/A,SXE/A,S1/A,VMQ,VMT/A,VS3,VS4,VS5,VS6,VX/A,VXE/A,VXEB/A VXK,VXU/A,VXU1/A
			-	-	(1)		
	13013-ZE3-005	RING SET, PISTON (0.75) (TEIKOKU)	(1)	(1)	-		BJ,EDE2,EDE2/A,EDN,EDN2,EDN2/A,EDN5,EDS,EDS1,EDS2,EDS2/A,EDS3 EDS5,EDS6,EDS6/A,EDT,EDT/A,EDT1,EDT2,EDT6,EDT6/A,ED6,ED6/A,ED7 ED8,ED9,EMT,EN,ENT,ENT/A,ENT2,EN6,EN6/A,ES,ES1,ES3,ES4,ET,ETS,ETX HA,HAQ,HA2,HA2/A,HH,HX,HX2,HX26,HX26/A,LH,LHB1,LHB3,LHC,LHE,LHQ4 LHQ4/A,LHW,LJ,LJG,LJS,LKE,LKE/A,LP,LSX,LT,LWD1,LX,LXE,LXE2,LXE2/A LXE4,LXE4/A,LXE6,LXE8,LXE8/A,LXQ4,LXQ4/A,LXU,LXU/A,LXZ,LX2,LX2/A LX26,LX26/A,L1,PKT2,PKT2/A,PKT4,PKT4/A,PKX2,PKX4,PKX4/A,PX,PXA2 PXE8,PXE8/A,P1,QA,QAB2,QAB2/A,QAC2,QAC2/A,QAE,QAE2,QAE2/A,QAE6 QAE6/A,QAG,QAG/A,QA2,QA2/A,QAP,QAPE,QAP2,QAP2/A,QAQ,QA2,QA2/A QA26,QA26/A,QDW9,QDW9/A,QE,QE/A,QH,QHB3,QHC,QHE,QHE/A,QHP1,QHQ4 QHQ4/A,QH2,QKA4,QKA4/A,QL2,QMEO,QMEO/A,QME8,QME8/A,QMH,QMT2 QMT2/A,QMX2,QNE,QNE2,QNE2/A,QNE6,QNE9,QNE9/A,QNR2,QNR2/A,QNR6 QNR6/A,QN18,QP,QPE2,QT,QT/A,QTC2,QTC2/A,QWH2,QWH2/A,QX,QXB,QXB/A QXB7,QXB7/A,QXC,QXC4,QXC4/A,QXC6,QXC6/A,QXC9,QXC9/A,QXE,QXE,QXE2 QXE4,QXE4/A,QXE6,QXE6/A,QXE8,QXE8/A,QXQ4,QXQ4/A,QXU,QXU/A,QX2,Q1 SDE,SE,SE/A,SH,SHB1,SHB3,SHB3/A,SHE,SHEZ,SHQ4,SHQ4/A,SHT,SJ,SJG SKE,SKZ,SME0,SME0/A,SME2,SMX2,SMX2/A,STJ,STP,STQ,STR,SWX,SWX/A,SX SXB,SXB/A,SXB7,SXB7/A,SXE,SXEB,SXEB/A,SXE2,SXE4,SXE4/A,SXE8 SXE8/A,SXP,SXQ4,SXQ4/A,SXU,SXU/A,S1,VA,VAA,VAE,VAD2,VAD2/A,VAH1 VAH2,VAW1,VA2,VA2/A,VC2,VC2/A,VDE,VDE2,VDE2/A,VD16,VE,VEB6,VH,VHE VH12,VH12/A,VH22,VH22/A,VMT,VMX,VNG,VNG1,VNG2,VSH7,VTE2,VMA,VMA2 VMC,VMC2,VMC2/A,VME,VME2,VME2/A,VMS2,VMS2/A,VM12,VM12/A,VX,VXA VXB,VXB/A,VXB2,VXB7,VXB7/A,VXE,VXEB,VXE2,VXE2/A,VXE4,VXE6,VXE7 VXE7/A,VXE8,VXE8/A,VXG,VXQ4,VXQ4/A,VXU,VXU1,VX16,VX16/A,VX8,VX8/A V1,YJ,ZK1,ZK1/A
			(1)	(1)	-	4099047	EDK,EDN5/A,EDS1/A,EDS4,EDT1/A,ED8/A,ED9/A,EMT/A,ES1/A,ES3/A,ES4/A LH/A,LHB3/A,LHB5,LHE/A,LJ/A,LJG/A,LJS/A,LJS1,LT/A,LWD,LWD1/A,LX/A LXE/A,L1/A,PX/A,P1/A,QH/A,QHB3/A,QHB5,QHP1/A,QMH/A,QP/A,QX/A QXC/A,QXE/A,Q1/A,SH/A,SJ/A,SJG/A,SKE/A,SKZ/A,STJ/A,STP/A,STQ/A STR/A,SX/A,SXE/A,S1/A,VMQ,VMT/A,VS3,VS4,VS5,VS6,VX/A,VXE/A,VXEB/A VXK,VXU/A,VXU1/A
			-	-	(1)		
	13010-Z5L-004	RING SET, PISTON (STD.) (TEIKOKU)	1	1	-	4099048	EDK,EDN5/A,EDS1/A,EDS4,EDT1/A,ED8/A,ED9/A,EMT/A,ES1/A,ES3/A,ES4/A LH/A,LHB3/A,LHB5,LHE/A,LJ/A,LJG/A,LJS/A,LJS1,LT/A,LWD,LWD1/A,LX/A LXE/A,L1/A,PX/A,P1/A,QH/A,QHB3/A,QHB5,QHP1/A,QMH/A,QP/A,QX/A QXC/A,QXE/A,Q1/A,SH/A,SJ/A,SJG/A,SKE/A,SKZ/A,STJ/A,STP/A,STQ/A STR/A,SX/A,SXE/A,S1/A,VMQ,VMT/A,VS3,VS4,VS5,VS6,VX/A,VXE/A,VXEB/A VXK,VXU/A,VXU1/A
			1	-	-		EDT3,ES2,VS2,VS7
	13011-Z5L-004	RING SET, PISTON (0.25) (TEIKOKU)	(1)	(1)	-	4099048	EDK,EDN5/A,EDS1/A,EDS4,EDT1/A,ED8/A,ED9/A,EMT/A,ES1/A,ES3/A,ES4/A LH/A,LHB3/A,LHB5,LHE/A,LJ/A,LJG/A,LJS/A,LJS1,LT/A,LWD,LWD1/A,LX/A LXE/A,L1/A,PX/A,P1/A,QH/A,QHB3/A,QHB5,QHP1/A,QMH/A,QP/A,QX/A QXC/A,QXE/A,Q1/A,SH/A,SJ/A,SJG/A,SKE/A,SKZ/A,STJ/A,STP/A,STQ/A STR/A,SX/A,SXE/A,S1/A,VMQ,VMT/A,VS3,VS4,VS5,VS6,VX/A,VXE/A,VXEB/A VXK,VXU/A,VXU1/A
			(1)	-	-		EDT3,ES2,VS2,VS7

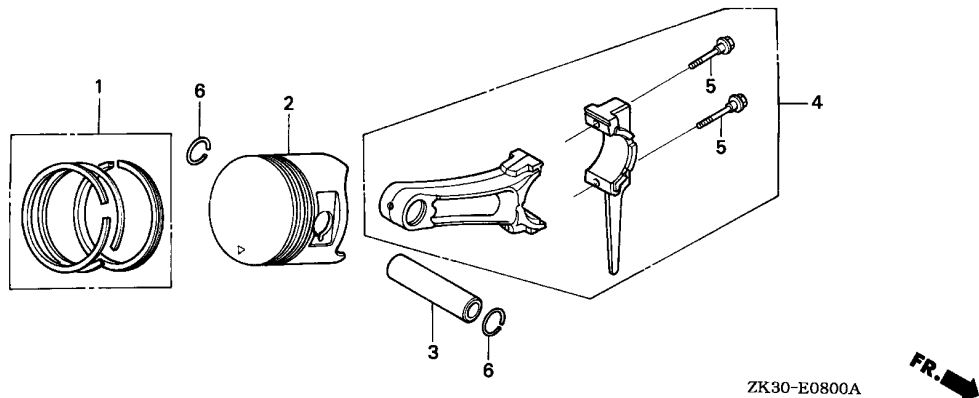

2

Ref. No.	Part No.	Description	Reqd. QTY			Serial No.	Parts catalogue code
			GX	340K1	(3)		
(1)	13012-Z5L-004	RING SET, PISTON (0.50) (TEIKOKU)	(1)	(1)	-	4099048	----- EDK,EDN5/A,EDS1/A,EDS4,EDT1/A,ED8/A,ED9/A,EMT/A,ES1/A,ES3/A,ES4/A LH/A,LHB3/A,LHB5,LHE/A,LJ/A,LJG/A,LJS/A,LJS1,LT/A,LWD,LWD1/A,LX/A LXE/A,L1/A,PX/A,P1/A,QH/A,QHB3/A,QHB5,QHP1/A,QMH/A,QP/A,QX/A QXC/A,QXE/A,Q1/A,SH/A,SJ/A,SJG/A,SKE/A,SKZ/A,STJ/A,STP/A,STQ/A STR/A,SX/A,SXE/A,S1/A,VMQ,VMT/A,VS3,VS4,VS5,VS6,VX/A,VXE/A,VXEB/A VXK,VXU/A,VXU1/A EDT3,ES2,VS2,VS7
	13013-Z5L-004	RING SET, PISTON (0.75) (TEIKOKU)	(1)	(1)	-	4099048	----- EDK,EDN5/A,EDS1/A,EDS4,EDT1/A,ED8/A,ED9/A,EMT/A,ES1/A,ES3/A,ES4/A LH/A,LHB3/A,LHB5,LHE/A,LJ/A,LJG/A,LJS/A,LJS1,LT/A,LWD,LWD1/A,LX/A LXE/A,L1/A,PX/A,P1/A,QH/A,QHB3/A,QHB5,QHP1/A,QMH/A,QP/A,QX/A QXC/A,QXE/A,Q1/A,SH/A,SJ/A,SJG/A,SKE/A,SKZ/A,STJ/A,STP/A,STQ/A STR/A,SX/A,SXE/A,S1/A,VMQ,VMT/A,VS3,VS4,VS5,VS6,VX/A,VXE/A,VXEB/A VXK,VXU/A,VXU1/A EDT3,ES2,VS2,VS7



Ref. No.	Part No.	Description	Reqd. QTY			Serial No.	Parts catalogue code
			(1)	(2)	(3)		
2	13101-ZE3-W00	PISTON (STD.)	1	1	-	-----	BJ, EDE2, EDE2/A, EDN, EDN2, EDN2/A, EDN5, EDS, EDS1, EDS2, EDS2/A, EDS3, EDS5, EDS6, EDS6/A, EDT, EDT/A, EDT1, EDT2, EDT6, EDT6/A, ED6, ED6/A, ED7, ED8, ED9, EMT, EN, ENT, ENT/A, ENT2, EN6, EN6/A, ES, ES1, ES3, ES4, ET, ETS, ETX, HA, HAQ, HA2, HA2/A, HH, HX, HX2, HX26, HX26/A, LH, LHB1, LHB3, LHC, LHE, LHQ4, LHQ4/A, LHW, LJ, LJG, LJS, LKE, LKE/A, LP, LSX, LT, LWD1, LX, LXE, LXE2, LXE2/A, LXE4, LXE4/A, LXE6, LXE8, LXE8/A, LXQ4, LXQ4/A, LXU, LXU/A, LXZ, LX2, LX2/A, LX26, LX26/A, L1, PKT2, PKT2/A, PKT4, PKT4/A, PKX2, PKX4, PKX4/A, PX, PXA2, PXE8, PXE8/A, P1, QA, QAB2, QAB2/A, QAC2, QAC2/A, QAE, QAE2, QAE2/A, QAE6, QAE6/A, QAG, QAG/A, QAH2, QAH2/A, QAP, QAPE, QAP2, QAP2/A, QAQ, QA2, QA2/A, QA26, QA26/A, QDW9, QDW9/A, QE, QE/A, QH, QHB3, QHC, QHE, QHE/A, QHP1, QHQ4, QHQ4/A, QH2, QKA4, QKA4/A, QL2, QMEO, QMEO/A, QME8, QME8/A, QMH, QMT2, QMT2/A, QMX2, QNE, QNE2, QNE2/A, QNE6, QNE9, QNE9/A, QNR2, QNR2/A, QNR6, QNR6/A, QN18, QP, QPE2, QTC2, QTC2/A, QWH2, QWH2/A, QX, QXB, QXB/A, QXB7, QXB7/A, QXC, QXC4, QXC4/A, QXC6, QXC6/A, QXC9, QXC9/A, QXE, QXEB, QXE2, QXE4, QXE4/A, QXE6, QXE6/A, QXE8, QXE8/A, QXQ4, QXQ4/A, QXU, QXU/A, QX2, Q1, SDE, SE, SE/A, SH, SHB1, SHB3, SHB3/A, SHE, SHEZ, SHQ4, SHQ4/A, SHT, SJ, SJG, SKE, SKZ, SMEO, SMEO/A, SME2, SMX2, SMX2/A, STJ, STP, STQ, STR, SWX, SWX/A, SX, SXB, SXB/A, SXB7, SXB7/A, SXE, SXEB, SXEB/A, SXE2, SXE4, SXE4/A, SXE8, SXE8/A, SXP, SXQ4, SXQ4/A, SXU, SXU/A, S1, VA, VAA, VAAE, VAD2, VAD2/A, VAH1, VAH2, VAW1, VA2, VA2/A, VC2, VC2/A, VDE, VDE2, VDE2/A, VD16, VE, VEB6, VH, VHE, VH12, VH12/A, VH22, VH22/A, VMT, VMX, VNG, VNG1, VNG2, VSH7, VTE2, VWA, VWA2, VWC, VWC2, VWC2/A, VWE, VWE2, VWE2/A, VWS2, VWS2/A, VW12, VW12/A, VX, VXA, VXB, VXB/A, VXB2, VXB7, VXB7/A, VXE, VXE8, VXE2, VXE2/A, VXE4, VXE6, VXE7, VXE7/A, VXE8, VXE8/A, VXG, VXQ4, VXQ4/A, VXU, VXU1, VX16, VX16/A, VX8, VX8/A, V1, YJ, ZK1, ZK1/A
			1	1	-	-----	4099047 EDK, EDN5/A, EDS1/A, EDS4, EDT1/A, ED8/A, ED9/A, EMT/A, ES1/A, ES3/A, ES4/A, LH/A, LHB3/A, LHB5, LHE/A, LJ/A, LJG/A, LJS/A, LJS1, LT/A, LWD, LWD1/A, LX/A, LXE/A, L1/A, PX/A, P1/A, QH/A, QHB3/A, QHB5, QHP1/A, QMH/A, QP/A, QX/A, QXC/A, QXE/A, Q1/A, SH/A, SJ/A, SJG/A, SKE/A, SKZ/A, STJ/A, STP/A, STQ/A, STR/A, SX/A, SXE/A, S1/A, VMQ, VMT/A, VS3, VS4, VS5, VS6, VX/A, VXE/A, VXE8/A, VXE8/A, VXK, VXU/A, VXU1/A
	13101-ZE3-810	.....	-	-	1	-----	QT, QT/A



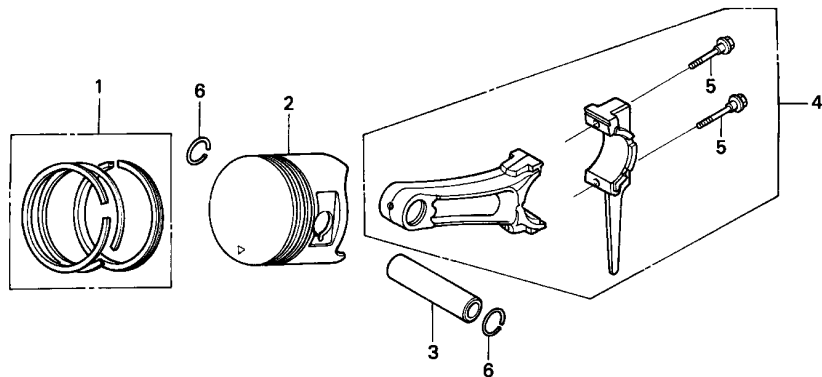

ZK30-E0800A



2

Ref. No.	Part No.	Description	Reqd. QTY			Serial No.	Parts catalogue code
			GX	340K1	(3)		
(2)	13102-ZE3-W00	PISTON (0.25)	(1)	(2)	(3)	-	BJ, EDE2, EDE2/A, EDN, EDN2, EDN2/A, EDN5, EDS, EDS1, EDS2, EDS2/A, EDS3, EDS5, EDS6, EDS6/A, EDT, EDT/A, EDT1, EDT2, EDT6, EDT6/A, ED6, ED6/A, ED7, ED8, ED9, EMT, EN, ENT, ENT/A, ENT2, EN6, EN6/A, ES, ES1, ES3, ES4, ET, ETS, ETX, HA, HAQ, HA2, HA2/A, HH, HX, HX2, HX26, HX26/A, LH, LHB1, LHB3, LHC, LHE, LHQ4, LHQ4/A, LHW, LJ, LJG, LJS, LKE, LKE/A, LP, LSX, LT, LWD1, LX, LXE, LXE2, LXE2/A, LXE4, LXE4/A, LXE6, LXE8, LXE8/A, LXQ4, LXQ4/A, LXU, LXU/A, LXZ, LX2, LX2/A, LX26, LX26/A, L1, PKT2, PKT2/A, PKT4, PKT4/A, PKX2, PKX4, PKX4/A, PX, PXA2, PXE8, PXE8/A, P1, QA, QAB2, QAB2/A, QAC2, QAC2/A, QAE, QAE2, QAE2/A, QAE6, QAE6/A, QAG, QAG/A, QAH2, QAH2/A, QAP, QAPE, QAP2, QAP2/A, QAQ, QA2, QA2/A, QA26, QA26/A, QDW9, QDW9/A, QE, QE/A, QH, QHB3, QHC, QHE, QHE/A, QHP1, QHQ4, QHQ4/A, QH2, QKA4, QKA4/A, QL2, QMEO, QMEO/A, QME8, QME8/A, QMH, QMT2, QMT2/A, QMX2, QNE, QNE2, QNE2/A, QNE6, QNE9, QNE9/A, QNR2, QNR2/A, QNR6, QNR6/A, QN18, QP, QPE2, QTC2, QTC2/A, QWH2, QWH2/A, QX, QXB, QXB/A, QXB7, QXB7/A, QXC, QXC4, QXC4/A, QXC6, QXC6/A, QXC9, QXC9/A, QXE, QXEB, QXE2, QXE4, QXE4/A, QXE6, QXE6/A, QXE8, QXE8/A, QXQ4, QXQ4/A, QXU, QXU/A, QX2, Q1, SDE, SE, SE/A, SH, SHB1, SHB3, SHB3/A, SHE, SHEZ, SHQ4, SHQ4/A, SHT, SJ, SJG, SKE, SKZ, SMEO, SMEO/A, SME2, SMX2, SMX2/A, STJ, STP, STQ, STR, SWX, SWX/A, SX, SXB, SXB/A, SXB7, SXB7/A, SXE, SXEB, SXEB/A, SXE2, SXE4, SXE4/A, SXE8, SXE8/A, SXP, SXQ4, SXQ4/A, SXU, SXU/A, S1, VA, VAA, VAAE, VAD2, VAD2/A, VAH1, VAH2, VAW1, VA2, VA2/A, VC2, VC2/A, VDE, VDE2, VDE2/A, VD16, VE, VEB6, VH, VHE, VH12, VH12/A, VH22, VH22/A, VMT, VMX, VNG, VNG1, VNG2, VSH7, VTE2, VWA, VWA2, VWC, VWC2, VWC2/A, VWE, VWE2, VWE2/A, VWS2, VWS2/A, VW12, VW12/A, VX, VXA, VXB, VXB/A, VXB2, VXB7, VXB7/A, VXE, VXE8, VXE2, VXE2/A, VXE4, VXE6, VXE7, VXE7/A, VXE8, VXE8/A, VXG, VXQ4, VXQ4/A, VXU, VXU1, VX16, VX16/A, VX8, VX8/A, V1, YJ, ZK1, ZK1/A

Ref. No.	Part No.	Description	Reqd. QTY			Serial No.	Parts catalogue code
			GX 340K1	(1)	(2)		
(2)	13102-ZE3-W00	PISTON (0.25) .....	(1)	(1)	-	4099047	EDK,EDN5/A,EDS1/A,EDS4,EDT1/A,ED8/A,ED9/A,EMT/A,ES1/A,ES3/A,ES4/A,LH/A,LHB3/A,LHB5,LHE/A,LJ/A,LJG/A,LJS/A,LJS1,LT/A,LWD,LWD1/A,LX/A,LXE/A,L1/A,PX/A,P1/A,QH/A,QHB3/A,QHB5,QHP1/A,QMH/A,QP/A,QX/A,QXC/A,QXE/A,Q1/A,SH/A,SJ/A,SJG/A,SKE/A,SKZ/A,STJ/A,STP/A,STQ/A,STR/A,SX/A,SXE/A,S1/A,VMQ,VMT/A,VS3,VS4,VS5,VS6,VX/A,VXE/A,VXEB/A,VXK,VXU/A,VXU1/A
	13102-ZE3-810 .....		-	-	(1)		QT,QT/A
	13103-ZE3-W00	PISTON (0.50) .....	(1)	(1)	-		BJ,EDE2,EDE2/A,EDN,EDN2,EDN2/A,EDN5,EDS,EDS1,EDS2,EDS2/A,EDS3,EDS5,EDS6,EDS6/A,EDT,EDT/A,EDT1,EDT2,EDT6,EDT6/A,ED6,ED6/A,ED7,ED8,ED9,EMT,EN,ENT,ENT/A,ENT2,EN6,EN6/A,ES,ES1,ES3,ES4,ET,ETS,ETX,HA,HAQ,HA2,HA2/A,HH,HX,HX2,HX26,HX26/A,LH,LHB1,LHB3,LHC,LHE,LHQ4,LHQ4/A,LHW,LJ,LJG,LJS,LKE,LKE/A,LP,LSX,LT,LWD1,LX,LXE,LXE2,LXE2/A,LXE4,LXE4/A,LXE6,LXE8,LXE8/A,LXQ4,LXQ4/A,LXU,LXU/A,LX2,LX2,A,LX26,LX26/A,L1,PKT2,PKT2/A,PKT4,PKT4/A,PKX2,PKX4,PKX4/A,PX,PXA2,PXE8,PXE8/A,P1,QA,QAB2,QAB2/A,QAC2,QAC2/A,QAQ,QAQ2,QAQ2/A,QAQ2,QAQ2/A,QAQ2,QAQ2/A,QAE6/A,QAQ6,QAQ6/A,QAQ2,QAQ2/A,QAP,QAPE,QAP2,QAP2/A,QAQ,QA2,QA2/A,QA26,QA26/A,QDW9,QDW9/A,QE,QE/A,QH,QHB3,QHC,QHE,QHE/A,QHP1,QHQ4,QHQ4/A,QH2,QAQ4,QAQ4/A,QL2,QMEO,QMEO/A,QME8,QME8/A,QMH,QMT2,QMT2/A,QMX2,QNE,QNE2,QNE2/A,QNE6,QNE9,QNE9/A,QNR2,QNR2/A,QNR6,QNR6/A,QN18,QP,QPE2,QTC2,QTC2/A,QWH2,QWH2/A,QX,QXB,QXB/A,QXB7,QXB7/A,QXC,QXC4,QXC4/A,QXC6,QXC6/A,QXC9,QXC9/A,QXE,QXEB,QXE2,QXE4,QXE4/A,QXE6,QXE6/A,QXE8,QXE8/A,QXQ4,QXQ4/A,QXU,QXU/A,QX2,Q1,SDE,SE,SE/A,SH,SHB1,SHB3,SHB3/A,SHE,SHEZ,SHQ4,SHQ4/A,SHT,SJ,SJG,SKE,SKZ,SME0,SME0/A,SME2,SMX2,SMX2/A,STJ,STP,STQ,STR,SWX,SWX/A,SX,SXB,SXB/A,SXB7,SXB7/A,SXE,SXEB,SXEB/A,SXE2,SXE4,SXE4/A,SXE8,SXE8/A,SXP,SXQ4,SXQ4/A,SXU,SXU/A,S1,VA,VAA,VAE,VAD2,VAD2/A,VAH1,VAH2,VAW1,VA2,VA2/A,VC2,VC2/A,VDE,VDE2,VDE2/A,VD16,VE,VEB6,VH,VHE,VH12,VH12/A,VH22,VH22/A,VMT,VMX,VNG,VNG1,VNG2,VSH7,VTE2,VWA,VWA2,VWC,VWC2,VWC2/A,VWE,VWE2,VWE2/A,VWS2,VWS2/A,VW12,VW12/A,VX,VXA,VXB,VXB/A,VXB2,VXB7,VXB7/A,VXE,VXEB,VXE2,VXE2/A,VXE4,VXE6,VXE7,VXE7/A,VXE8,VXE8/A,VXG,VXQ4,VXQ4/A,VXU,VXU1,VX16,VX16/A,VX8,VX8/A,V1,YJ,ZK1,ZK1/A
	13103-ZE3-810 .....		-	-	(1)		QT,QT/A



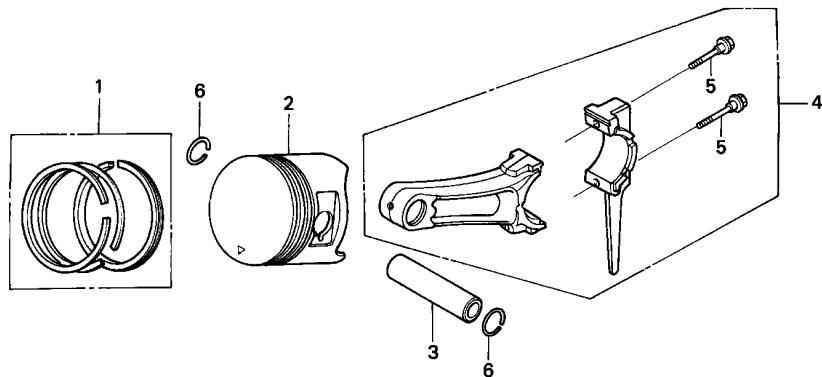

ZK30-E0800A



2

Ref. No.	Part No.	Description	Reqd. QTY			Serial No.	Parts catalogue code
			GX	340K1			
			(1)	(2)	(3)		
(2)	13104-ZE3-W00	PISTON (0.75)	(1)	(1)	-	-----	BJ, EDE2, EDE2/A, EDN, EDN2, EDN2/A, EDN5, EDS, EDS1, EDS2, EDS2/A, EDS3, EDS5, EDS6, EDS6/A, EDT, EDT/A, EDT1, EDT2, EDT6, EDT6/A, ED6, ED6/A, ED7, ED8, ED9, EMT, EN, ENT, ENT/A, ENT2, EN6, EN6/A, ES, ES1, ES3, ES4, ET, ETS, ETX, HA, HAQ, HA2, HA2/A, HH, HX, HX2, HX26, HX26/A, LH, LHB1, LHB3, LHC, LHE, LHQ4, LHQ4/A, LHW, LJ, LJG, LJS, LKE, LKE/A, LP, LSX, LT, LWD1, LX, LXE, LXE2, LXE2/A, LXE4, LXE4/A, LXE6, LXE8, LXE8/A, LXQ4, LXQ4/A, LXU, LXU/A, LXZ, LX2, LX2/A, LX26, LX26/A, L1, PKT2, PKT2/A, PKT4, PKT4/A, PKX2, PKX4, PKX4/A, PX, PXA2, PXE8, PXE8/A, P1, QA, QAB2, QAB2/A, QAC2, QAC2/A, QAE, QAE2, QAE2/A, QAE6, QAE6/A, QAG, QAG/A, QAH2, QAH2/A, QAP, QAPE, QAP2, QAP2/A, QAQ, QA2, QA2/A, QA26, QA26/A, QDW9, QDW9/A, QE, QE/A, QH, QHB3, QHC, QHE, QHE/A, QHP1, QHQ4, QHQ4/A, QH2, QKA4, QKA4/A, QL2, QMEO, QMEO/A, QME8, QME8/A, QMH, QMT2, QMT2/A, QMX2, QNE, QNE2, QNE2/A, QNE6, QNE9, QNE9/A, QNR2, QNR2/A, QNR6, QNR6/A, QN18, QP, QPE2, QTC2, QTC2/A, QWH2, QWH2/A, QX, QXB, QXB/A, QXB7, QXB7/A, QXC, QXC4, QXC4/A, QXC6, QXC6/A, QXC9, QXC9/A, QXE, QXEB, QXE2, QXE4, QXE4/A, QXE6, QXE6/A, QXE8, QXE8/A, QXQ4, QXQ4/A, QXU, QXU/A, QX2, Q1, SDE, SE, SE/A, SH, SHB1, SHB3, SHB3/A, SHE, SHEZ, SHQ4, SHQ4/A, SHT, SJ, SJG, SKE, SKZ, SMEO, SMEO/A, SME2, SMX2, SMX2/A, STJ, STP, STQ, STR, SWX, SWX/A, SX, SXB, SXB/A, SXB7, SXB7/A, SXE, SXEB, SXEB/A, SXE2, SXE4, SXE4/A, SXE8, SXE8/A, SXP, SXQ4, SXQ4/A, SXU, SXU/A, S1, VA, VAA, VAAE, VAD2, VAD2/A, VAH1, VAH2, VAW1, VA2, VA2/A, VC2, VC2/A, VDE, VDE2, VDE2/A, VD16, VE, VEB6, VH, VHE, VH12, VH12/A, VH22, VH22/A, VMT, VMX, VNG, VNG1, VNG2, VSH7, VTE2, VWA, VWA2, VWC, VWC2, VWC2/A, VWE, VWE2, VWE2/A, VWS2, VWS2/A, VW12, VW12/A, VX, VXA, VXB, VXB/A, VXB2, VXB7, VXB7/A, VXE, VXE8, VXE2, VXE2/A, VXE4, VXE6, VXE7, VXE7/A, VXE8, VXE8/A, VXG, VXQ4, VXQ4/A, VXU, VXU1, VX16, VX16/A, VX8, VX8/A, V1, YJ, ZK1, ZK1/A

Ref. No.	Part No.	Description	Reqd. QTY			Serial No.	Parts catalogue code
			(1)	(2)	(3)		
(2)	13104-ZE3-W00	PISTON (0.75) .....	(1)	(1)	-	4099047	EDK,EDN5/A,EDS1/A,EDS4,EDT1/A,ED8/A,ED9/A,EMT/A,ES1/A,ES3/A,ES4/A LH/A,LHB3/A,LHB5,LHE/A,LJ/A,LJG/A,LJS/A,LJS1,LT/A,LWD,LWD1/A,LX/A LXE/A,L1/A,PX/A,P1/A,QH/A,QHB3/A,QHB5,QHP1/A,QMH/A,QP/A,QX/A QXC/A,QXE/A,Q1/A,SH/A,SJ/A,SJG/A,SKE/A,SKZ/A,STJ/A,STP/A,STQ/A STR/A,SX/A,SXE/A,S1/A,VMQ,VMT/A,VS3,VS4,VS5,VS6,VX/A,VXE/A,VXEB/A VXK,VXU/A,VXU1/A
			-	-	(1)		
	13104-ZE3-810	.....	(1)	-	-		QT,QT/A
	13101-ZE3-W01	PISTON (STD.) .....	1	1	-	4099048	EDK,EDN5/A,EDS1/A,EDS4,EDT1/A,ED8/A,ED9/A,EMT/A,ES1/A,ES3/A,ES4/A LH/A,LHB3/A,LHB5,LHE/A,LJ/A,LJG/A,LJS/A,LJS1,LT/A,LWD,LWD1/A,LX/A LXE/A,L1/A,PX/A,P1/A,QH/A,QHB3/A,QHB5,QHP1/A,QMH/A,QP/A,QX/A QXC/A,QXE/A,Q1/A,SH/A,SJ/A,SJG/A,SKE/A,SKZ/A,STJ/A,STP/A,STQ/A STR/A,SX/A,SXE/A,S1/A,VMQ,VMT/A,VS3,VS4,VS5,VS6,VX/A,VXE/A,VXEB/A VXK,VXU/A,VXU1/A
			1	-	-		EDT3,ES2,VS2,VS7
	13102-ZE3-W01	PISTON (0.25) .....	(1)	(1)	-	4099048	EDK,EDN5/A,EDS1/A,EDS4,EDT1/A,ED8/A,ED9/A,EMT/A,ES1/A,ES3/A,ES4/A LH/A,LHB3/A,LHB5,LHE/A,LJ/A,LJG/A,LJS/A,LJS1,LT/A,LWD,LWD1/A,LX/A LXE/A,L1/A,PX/A,P1/A,QH/A,QHB3/A,QHB5,QHP1/A,QMH/A,QP/A,QX/A QXC/A,QXE/A,Q1/A,SH/A,SJ/A,SJG/A,SKE/A,SKZ/A,STJ/A,STP/A,STQ/A STR/A,SX/A,SXE/A,S1/A,VMQ,VMT/A,VS3,VS4,VS5,VS6,VX/A,VXE/A,VXEB/A VXK,VXU/A,VXU1/A
			(1)	-	-		EDT3,ES2,VS2,VS7
	13103-ZE3-W01	PISTON (0.50) .....	(1)	(1)	-	4099048	EDK,EDN5/A,EDS1/A,EDS4,EDT1/A,ED8/A,ED9/A,EMT/A,ES1/A,ES3/A,ES4/A LH/A,LHB3/A,LHB5,LHE/A,LJ/A,LJG/A,LJS/A,LJS1,LT/A,LWD,LWD1/A,LX/A LXE/A,L1/A,PX/A,P1/A,QH/A,QHB3/A,QHB5,QHP1/A,QMH/A,QP/A,QX/A QXC/A,QXE/A,Q1/A,SH/A,SJ/A,SJG/A,SKE/A,SKZ/A,STJ/A,STP/A,STQ/A STR/A,SX/A,SXE/A,S1/A,VMQ,VMT/A,VS3,VS4,VS5,VS6,VX/A,VXE/A,VXEB/A VXK,VXU/A,VXU1/A
			(1)	-	-		EDT3,ES2,VS2,VS7
	13104-ZE3-W01	PISTON (0.75) .....	(1)	(1)	-	4099048	EDK,EDN5/A,EDS1/A,EDS4,EDT1/A,ED8/A,ED9/A,EMT/A,ES1/A,ES3/A,ES4/A LH/A,LHB3/A,LHB5,LHE/A,LJ/A,LJG/A,LJS/A,LJS1,LT/A,LWD,LWD1/A,LX/A LXE/A,L1/A,PX/A,P1/A,QH/A,QHB3/A,QHB5,QHP1/A,QMH/A,QP/A,QX/A QXC/A,QXE/A,Q1/A,SH/A,SJ/A,SJG/A,SKE/A,SKZ/A,STJ/A,STP/A,STQ/A STR/A,SX/A,SXE/A,S1/A,VMQ,VMT/A,VS3,VS4,VS5,VS6,VX/A,VXE/A,VXEB/A VXK,VXU/A,VXU1/A
			(1)	-	-		EDT3,ES2,VS2,VS7
3	13111-ZF6-000	PIN, PISTON .....	1	1	1		
4	13200-ZE3-010	ROD ASSY., CONNECTING (STD.)	1	1	-		BJ,EDN,EDS,EDS3,EDS5,EDT2,ED7,EN,ES,ET,ETS,ETX,HA,HAQ,HH,HX,HX2 LHB1,LHC,LHW,LP,LSX,LXE6,LXZ,QA,QAE,QAP,QAPE,QAQ,QHC,QH2,QL2,QMX2 QNE,QNE6,QN18,QPE2,QXEB,QXE2,QX2,SDE,SHB1,SHE,SHE2,SHT,SME2,SXE2 SXP,VA,VAA,VAE,VAH1,VAH2,VAW1,VDE,VD16,VE,VEB6,VH,VHE,VMX,VNG VNG1,VNG2,VTE2,VWA,VWA2,VXA,VXB2,VXE4,VXE6,VXG,V1,YJ
			1	1	-	3413369	EDE2,EDN2,EDN5,EDS1,EDS2,EDS6,EDT,EDT1,EDT6,ED6,ED8,ED9,ES1,ES3 ES4,HA2,HX26,LH,LHB3,LHE,LHQ4,LJ,LJG,LKE,LT,LWD1,LX,LXE,LXE2,LXE4 LXE8,LXQ4,LXU,LX2,LX26,L1,PKT2,PKT4,PKX4,PX,PXE8,P1,QAB2,QAC2 QAE2,QAE6,QAG,QAQ2,QAP2,QA2,QA26,QDW9,QE,QH,QHB3,QHE,QHP1,QHQ4 QKA4,QME0,QME8,QMH,QMT2,QNE2,QNE9,QNR2,QNR6,QP,QT,QTC2,QWH2,QX QXB,QXC,QXC4,QXC6,QXC9,QXE,QXE4,QXE6,QXE8,QXQ4,QXU,Q1,SE,SH,SHB3 SHQ4,SJ,SJG,SKE,SKZ,SME0,SMX2,STJ,STP,STQ,STR,SWX,SX,SBX,SXE,SXB SXE4,SXE8,SXQ4,SXU,S1,VAD2,VA2,VC2,VDE2,VH12,VH22,VMT,VWC2,VWE2 VWS2,VW12,VX,VXB,VXE,VXEB,VXE2,VXE8,VXQ4,VXU,VXU1,VX16,VX8,ZK1
			-	-	1		



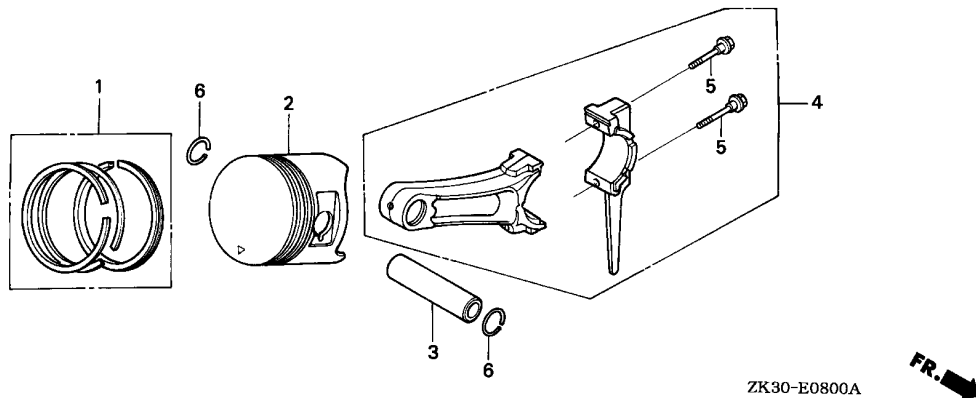

2

Ref. No.	Part No.	Description	Reqd. QTY			Serial No.	Parts catalogue code
			GX	340K1			
			(1)	(2)	(3)		
(4)	13200-ZE3-020	ROD ASSY., CONNECTING (STD.)	1	1	-	-----	EDE2/A,EDK,EDN2/A,EDN5/A,EDS1/A,EDS2/A,EDS4,EDS6/A,EDT/A,EDT1/A,EDT3,EDT6/A,ED6/A,ED8/A,ED9/A,EMT,EMT/A,ENT,ENT/A,ENT2,EN6,EN6/A,ES1/A,ES2,ES3/A,ES4/A,HA2/A,HX26/A,LH/A,LHB3/A,LHB5,LHE/A,LHQ4/A,LJ/A,LJG/A,LJS,LJS/A,LJS1,LKE/A,LT/A,LWD,LWD1/A,LX/A,LXE/A,LXE2/A,LXE4/A,LXE8/A,LXQ4/A,LXU/A,LX2/A,LX26/A,L1/A,PKT2/A,PKT4/A,PKX2,PKX4/A,PX/A,PXA2,PXE8/A,P1/A,QAB2/A,QAC2/A,QAE2/A,QAE6/A,QAG/A,QA2/A,QAP2/A,QA2/A,QA26/A,QDW9/A,QE/A,QH/A,QHB3/A,QHB5,QHE/A,QHP1/A,QHQ4/A,QKA4/A,QMEO/A,QME8/A,QMH/A,QMT2/A,QNE2/A,QNE9/A,QNR2/A,QNR6/A,QP/A,QT/A,QTC2/A,QWH2/A,QX/A,QXB/A,QXB7,QXB7/A,QXC/A,QXC4/A,QXC6/A,QXC9/A,QXE/A,QXE4/A,QXE6/A,QXE8/A,QXQ4/A,QXU/A,Q1/A,SE/A,SH/A,SHB3/A,SHQ4/A,SJ/A,SJG/A,SKE/A,SKZ/A,SMEO/A,SMX2/A,STJ/A,STP/A,STQ/A,STR/A,SWX/A,SX/A,SXB/A,SXB7,SXB7/A,SXE/A,SXE4/A,SXE8/A,SXQ4/A,SXU/A,S1/A,VAD2/A,VA2/A,VC2/A,VDE2/A,VH12/A,VH22/A,VMQ,VMT/A,VSH7,VS2,VS3,VS4,VS5,VS6,VS7,VVC,VVC2/A,VVE,VVE2/A,VWS2/A,VW12/A,VX/A,VXB/A,VXB7,VXB7/A,VXE/A,VXEB/A,VXE2/A,VXE7,VXE7/A,VXE8/A,VXK,VXQ4/A,VXU/A,VXU1/A,VX16/A,VX8/A,ZK1/A
			1	1	-	3413370 -----	EDE2,EDN2,EDN5,EDS1,EDS2,EDS6,EDT,EDT1,EDT6,ED6,ED8,ED9,ES1,ES3,ES4,HA2,HX26,LH,LHB3,LHE,LHQ4,LJ,LJG,LKE,LT,LWD1,LX,LXE,LXE2,LXE4,LXE8,LXQ4,LXU,LX2,LX26,L1,PKT2,PKT4,PKX4,PX,PXE8,P1,QAB2,QAC2,QAE2,QAE6,QAG,QA2,QAP2,QA2,QA26,QDW9,QE,QH,QHB3,QHE,QHP1,QHQ4,QKA4,QMEO,QME8,QMH,QMT2,QNE2,QNE9,QNR2,QNR6,QP,QT,QTC2,QWH2,QX,QXB,QXC,QXC4,QXC6,QXC9,QXE,QXE4,QXE6,QXE8,QXQ4,QXU,Q1,SE,SH,SHB3,SHQ4,SJ,SJG,SKE,SKZ,SMEO,SMX2,STJ,STP,STQ,STR,SWX,SX,SXB,SXE,SXE4,SXE8,SXQ4,SXU,S1,VAD2,VA2,VC2,VDE2,VH12,VH22,VMT,VVC2,VVE2,VWS2,VW12,VX,VXB,VXE,VXEB,VXE2,VXE8,VXQ4,VXU,VXU1,VX16,VX8,ZK1

Ref. No.	Part No.	Description	Reqd. QTY			Serial No.	Parts catalogue code
			(1)	(2)	(3)		
(4)	13200-ZE3-315	ROD ASSY., CONNECTING (0.25 UNDER SIZE)	(1)	-	-	-----	BJ, EDE2, EDE2/A, EDK, EDN, EDN2, EDN2/A, EDN5, EDN5/A, EDS, EDS1, EDS1/A, EDS2, EDS2/A, EDS3, EDS4, EDS5, EDS6, EDS6/A, EDT, EDT/A, EDT1, EDT1/A, EDT2, EDT3, EDT6, EDT6/A, ED6, ED6/A, ED7, ED8, ED8/A, ED9, ED9/A, EMT, EMT/A, ENT, ENT/A, EN6, EN6/A, ES, ES1, ES1/A, ES2, ES3, ES3/A, ES4, ES4/A, ET, ETS, ETX, HA, HAQ, HA2, HA2/A, HH, HX, HX2, HX26, HX26/A, LH, LH/A, LHB1, LHB3, LHB3/A, LHB5, LHC, LHE, LHE/A, LHQ4, LHQ4/A, LHW, LJ, LJ/A, LJG, LJG/A, LJS, LJS/A, LJS1, LKE, LKE/A, LP, LSX, LT, LT/A, LWD, LWD1, LWD1/A, LX, LX/A, LXE, LXE/A, LXE2, LXE2/A, LXE4, LXE4/A, LXE6, LXE8, LXE8/A, LXQ4, LXQ4/A, LXU, LXU/A, LXZ, LX2, LX2/A, LX26, LX26/A, PKT2, PKT2/A, PKT4, PKT4/A, PKX2, PKX4, PKX4/A, PX, PX/A, PXA2, PXE8, PXE8/A, QA, QAB2, QAB2/A, QAC2, QAC2/A, QAE, QAE2, QAE2/A, QAE6, QAE6/A, QAG, QAG/A, QAH2, QAH2/A, QAP, QAPE, QAP2, QAP2/A, QAQ, QA2, QA2/A, QA26, QA26/A, QDW9, QDW9/A, QE, QE/A, QH, QH/A, QHB3, QHB3/A, QHB5, QHC, QHE, QHE/A, QHP1, QHP1/A, QHQ4, QHQ4/A, QH2, QKA4, QKA4/A, QL2, QME0, QME0/A, QME8, QME8/A, QMH, QMH/A, QMT2, QMT2/A, QMX2, QNE, QNE2, QNE2/A, QNE6, QNE9, QNE9/A, QNR2, QNR2/A, QNR6, QNR6/A, QN18, QP, QP/A, QPE2, QT, QT/A, QTC2, QTC2/A, QWH2, QWH2/A, QX, QX/A, QXB, QXB/A, QXB7, QXB7/A, QXC, QXC/A, QXC4, QXC4/A, QXC6, QXC6/A, QXC9, QXC9/A, QXE, QXE/A, QXEB, QXE2, QXE4, QXE4/A, QXE6, QXE6/A, QXE8, QXE8/A, QXQ4, QXQ4/A, QXU, QXU/A, QX2, SDE, SE, SE/A, SH, SH/A, SHB1, SHB3, SHB3/A, SHE, SHEZ, SHQ4, SHQ4/A, SHT, SJ, SJ/A, SJG, SJG/A, SKE, SKE/A, SKZ, SKZ/A, SME0, SME0/A, SME2, SMX2, SMX2/A, STJ, STJ/A, STP, STP/A, STQ, STQ/A, STR, STR/A, SWX, SWX/A, SX, SX/A, SXB, SXB/A, SXB7, SXB7/A, SXE, SXE/A, SXEB, SXEB/A, SXE2, SXE4, SXE4/A, SXE8, SXE8/A, SXP, SXQ4, SXQ4/A, SXU, SXU/A, VA, VAA, VAAE, VAD2, VAD2/A, VAH1, VAH2, VAW1, VA2, VA2/A, VC2, VC2/A, VDE, VDE2, VDE2/A, VD16, VE, VEB6, VH, VHE, VH12, VH12/A, VH22, VH22/A, VMQ, VMT, VMT/A, VMX, VNG, VNG1, VNG2, VSH7, VS2, VS3, VS4, VS5, VS6, VS7, VTE2, VWA, VWA2, VWC, VWC2, VWC2/A, VWE, VWE2, VWE2/A, VWS2, VWS2/A, VW12, VW12/A, VX, VX/A, VXA, VXB, VXB/A, VXB2, VXB7, VXB7/A, VXE, VXE/A, VXE8, VXE8/A, VXE2, VXE2/A, VXE4, VXE6, VXE7, VXE7/A, VXE8, VXE8/A, VXG, VXX, VXQ4, VXQ4/A, VXU, VXU/A, VXU1, VXU1/A, VX16, VX16/A, VX8, VX8/A, YJ, ZK1, ZK1/A
	5 90001-ZE8-000	BOLT, CONNECTING ROD .....	-	(1)	(1)		
			2	2	2		
	6 90601-ZE3-000	CLIP, PISTON PIN, 20MM .....	2	2	2		



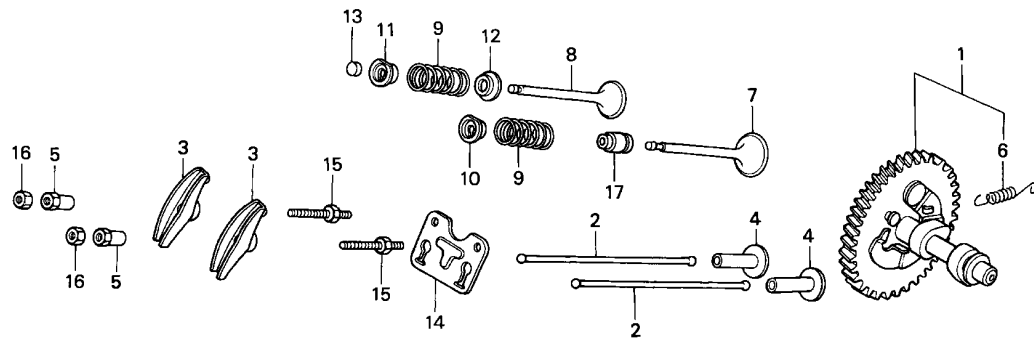

ZK30-E0900



Ref. No.	L.O.N.	(Relative ref. Number) Description	F.R.T.
1	1111C2	CAMSHAFT ..... .INCLUDES: Valve clearance adjustment	0.4
2	1111L6	ROD, PUSH :INTAKE ..... .INCLUDES: Valve clearance adjustment	0.2
	1111L6A	.Replace exhaust push rod add	0.1
	1111L7	ROD, PUSH :EXHAUST ..... .INCLUDES: Valve clearance adjustment	0.2
	1111L7A	.Replace intake push rod add	0.1
3	1111A2	ARM, ROCKER :INTAKE ..... .INCLUDES: Valve clearance adjustment	0.2
	1111A2A	.Replace exhaust rocker arm add	0.1
	1111A1	ARM, ROCKER :EXHAUST ..... .INCLUDES: Valve clearance adjustment	0.2
	1111A1A	.Replace intake rocker arm add	0.1
4	1111L9	LIFTER, VALVE :INTAKE ..... .INCLUDES: Valve clearance adjustment	0.4
		.NOTE: Same time for two units	
+	1111M0	LIFTER, VALVE :EXHAUST ..... .INCLUDES: Valve clearance adjustment	0.4

Ref. No.	Part No.	Description	Reqd. QTY			Serial No.	Parts catalogue code
			GX	340K1			
			(1)	(2)	(3)		
1	14100-ZE3-010	CAMSHAFT ASSY. ....	1	1	-	2708026	BJ,EDE2,EDN,EDN2,EDN5,EDS,EDS1,EDS2,EDS3,EDS5,EDT1,EDT2,ED6,ED7,ED8,ED9,EN,ES,ES1,ES3,ES4,ET,ETS,ETX,HA,HAQ,HA2,HH,HX,HX2,HX26,LHB1,LHB3,LHC,LHE,LHQ4,LHW,LJ,LJG,LKE,LSX,LX,LXE,LXE2,LXE4,LXE6,LXQ4,LXZ,LX2,LX26,L1,PKT2,PX,P1,QA,QAE,QAE2,QAE6,QA2,QAP,QAPE,QAP2,QAQ,QA2,QA26,QDW9,QE,QH,QHB3,QHC,QHE,QHP1,QHQ4,QH2,QMEO,QMH,QMT2,QNE,QNE2,QNE6,QNE9,QNR2,QNR6,QN18,QP,QPE2,QT,QTC2,QX,QXB,QXC,QXC4,QXC6,QXC9,QXE,QXEB,QXE2,QXE4,QXE6,QXQ4,QX2,Q1,SDE,SE,SH,SHB1,SHB3,SHE,SHEZ,SHQ4,SHT,SJ,SJG,SKZ,SME0,SME2,SMX2,STJ,STP,STQ,STR,SWX,SX,SXB,SXE,SXEB,SXE2,SXE4,SXP,SXQ4,S1,VA,VAA,VAE,VAD2,VAH1,VAH2,VAW1,VA2,VDE,VDE2,VD16,VE,VEB6,VH,VHE,VH12,VH22,VMX,VNG,VNG1,VNG2,VTE2,VVA,VWA2,VWC2,VWE2,VWS2,VW12,VX,VXA,VXB,VXB2,VXE,VXEB,VXE2,VXE4,VXE6,VXG,VXQ4,VXU,VXU1,VX16,V1,YJ,ZK1
	14100-ZF6-L01	.....	1	-	-	2708726	LP
	14100-ZF6-L02	.....	1	-	-	2708727	LP



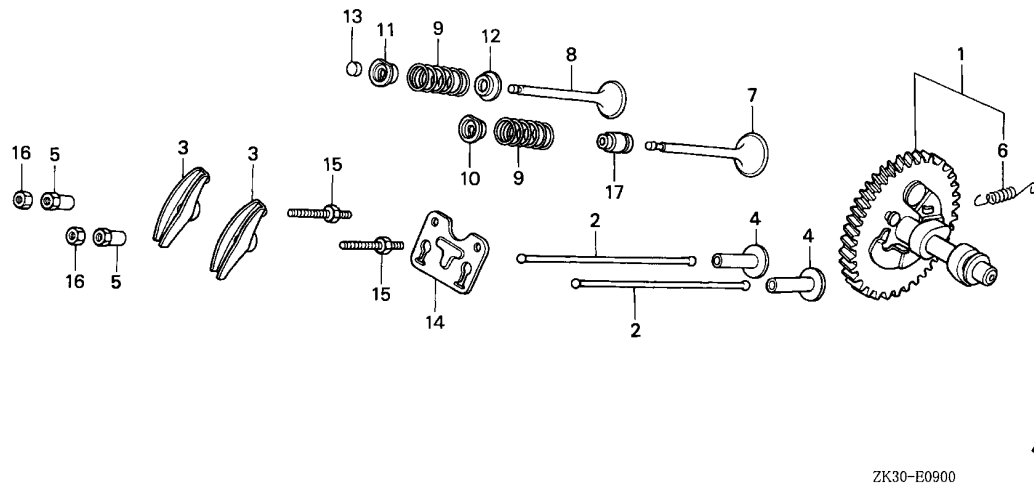

ZK30-E0900

Ref. No.	L.O.N.	(Relative ref. Number) Description	F.R.T.
+ 4		.INCLUDES: Valve clearance adjustment .NOTE: Same time for two units	
7	1111L1	VALVE, INTAKE .....	0.7
	1111L1E	.INCLUDES: Valve clearance adjustment and reface .Replace intake and exhaust all add .....	0.2
8	1111L0	VALVE, EXHAUST .....	0.7
	1111L0E	.INCLUDES: Valve clearance adjustment and reface .Replace intake and exhaust all add .....	0.2
9	1111P3	SPRING, VALVE :INTAKE .....	0.6
	1111P3A	.INCLUDES: Valve clearance adjustment .Replace intake and exhaust all add .....	0.1
	1111P4	SPRING, VALVE :EXHAUST .....	0.6
	1111P4A	.INCLUDES: Valve clearance adjustment .Replace intake and exhaust all add .....	0.1
+13	1111J7	ROTATOR, VALVE .....	0.2

Ref. No.	Part No.	Description	Reqd. QTY GX 340K1 (1) (2) (3)	Serial No.	Parts catalogue code
(1)	14100-ZE3-020	CAMSHAFT ASSY. ....	1 1 -	-----	EDE2/A,EDK,EDN2/A,EDN5/A,EDS1/A,EDS2/A,EDS4,EDS6,EDS6/A,EDT,EDT/A,EDT1/A,EDT3,EDT6,EDT6/A,ED6/A,ED8/A,ED9/A,EMT,EMT/A,ENT,ENT/A,ENT2,EN6,EN6/A,ES1/A,ES2,ES3/A,ES4/A,HA2/A,HX26/A,LH/A,LHB3/A,LHB5,LHE/A,LHQ4/A,LJ/A,LJG/A,LJS,LJS/A,LJS1,LKE/A,LT,LT/A,LWD,LWD1,LWD1/A,LX/A,LXE/A,LXE2/A,LXE4/A,LXE8,LXE8/A,LXQ4/A,LXU,LXU/A,LX2/A,LX26/A,L1/A,PKT2/A,PKT4,PKT4/A,PKX2,PKX4,PKX4/A,PX/A,PXA2,PXE8,PXE8/A,P1/A,QAB2,QAB2/A,QAC2,QAC2/A,QAE2/A,QAE6/A,QAG,QAG/A,QA2/A,QAP2/A,QA2/A,QA26/A,QDW9/A,QE/A,QH/A,QHB3/A,QHB5,QHE/A,QHP1/A,QHQ4/A,QKA4,QKA4/A,QL2,QME0/A,QME8,QME8/A,QMH/A,QMT2/A,QMX2,QNE2/A,QNE9/A,QNR2/A,QNR6/A,QP/A,QT/A,QTC2/A,QWH2,QWH2/A,QX/A,QXB/A,QXC/A,QXC4/A,QXC6/A,QXC9/A,QXE/A,QXE4/A,QXE6/A,QXE8,QXE8/A,QXQ4/A,QXU,QXU/A,Q1/A,SE/A,SH/A,SHB3/A,SHQ4/A,SJ/A,SJG/A,SKE,SKE/A,SKZ/A,SME0/A,SMX2/A,STJ/A,STP/A,STQ/A,STR/A,SWX/A,SX/A,SXB/A,SXE/A,SXEB/A,SXE4/A,SXE8,SXE8/A,SXQ4/A,SXU,SXU/A,S1/A,VAD2/A,VA2/A,VC2,VC2/A,VDE2/A,VH12/A,VH22/A,VMQ,VMT,VMT/A,VS2,VS3,VS4,VS5,VS6,VS7,VWC,VWC2/A,VWE,VWE2/A,VWS2/A,VW12/A,VX/A,VXB/A,VXE/A,VXEB/A,VXE2/A,VXE8,VXE8/A,VXK,VXQ4/A,VXU/A,VXU1/A,VX16/A,VX8,VX8/A,ZK1/A



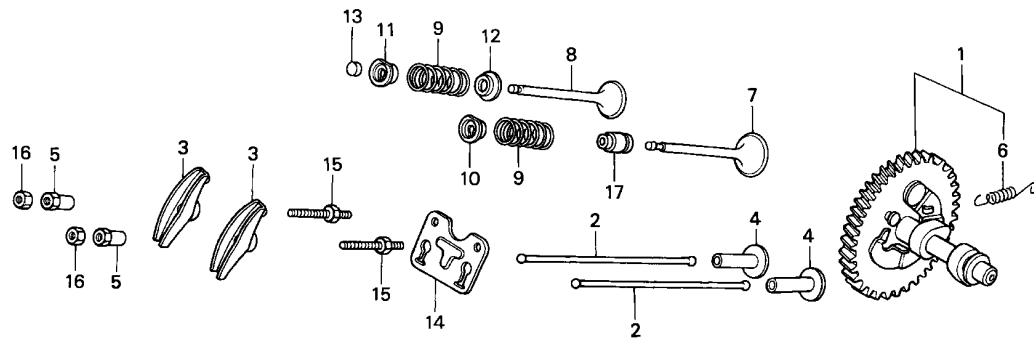

ZK30-E0900



Ref. No.	L.O.N.	(Relative ref. Number) Description	F.R.T.
+13		.INCLUDES: Valve clearance adjustment	
17	1111K2	SEAL, INTAKE VALVE STEM .....	0.6

Ref. No.	Part No.	Description	Reqd. QTY			Serial No.	Parts catalogue code
			GX	340K1			
			(1)	(2)	(3)		
(1)	14100-ZE3-020	CAMSHAFT ASSY. ....	1	1	-	2708027 -----	BJ,EDE2,EDN,EDN2,EDN5,EDS,EDS1,EDS2,EDS3,EDS5,EDT1,EDT2,ED6,ED7,ED8,ED9,EN,ES,ES1,ES3,ES4,ET,ETS,ETX,HA,HAQ,HA2,HH,HX,HX2,HX26,LH,LHB1,LHB3,LHC,LHE,LHQ4,LHW,LJ,LJG,LKE,LSX,LX,LXE,LXE2,LXE4,LXE6,LXQ4,LXZ,LX2,LX26,L1,PKT2,PX,P1,QA,QAE,QAE2,QAE6,QA2,QAP,QAPE,QAP2,QAQ,QA2,QA26,QDW9,QE,QH,QHB3,QHC,QHE,QHP1,QHQ4,QH2,QMEO,QMH,QMT2,QNE,QNE2,QNE6,QNE9,QNR2,QNR6,QN18,QP,QPE2,QT,QTC2,QX,QXB,QXC,QXC4,QXC6,QXC9,QXE,QXEB,QXE2,QXE4,QXE6,QXQ4,QX2,Q1,SDE,SE,SH,SHB1,SHB3,SHE,SHEZ,SHQ4,SHT,SJ,SJG,SKZ,SME0,SME2,SMX2,STJ,STP,STQ,STR,SWX,SX,SXB,SXE,SXEB,SXE2,SXE4,SXP,SXQ4,S1,VA,VAA,VAE,VAD2,VAH1,VAH2,VAW1,VA2,VDE,VDE2,VD16,VE,VEB6,VH,VHE,VH12,VH22,VMX,VNG,VNG1,VNG2,VTE2,VWA,VWA2,VWC2,VWE2,VWS2,VW12,VX,VXA,VXB,VXB2,VXE,VXEB,VXE2,VXE4,VXE6,VXG,VXQ4,VXU,VXU1,VX16,V1,YJ,ZK1
	14100-ZK3-870	.....	-	-	1	-----	QXB7,QXB7/A,SXB7,SXB7/A,VSH7,VXB7,VXB7/A,VXE7,VXE7/A
2	14410-ZE3-013	ROD, PUSH .....	2	2	2		
3	14431-ZE2-010	ARM, VALVE ROCKER .....	2	2	2		
4	14441-ZE2-000	LIFTER, VALVE .....	2	2	2		
5	14451-ZE1-013	PIVOT, ROCKER ARM .....	2	2	2		

Ref. No.	Part No.	Description	Reqd. QTY			Serial No.	Parts catalogue code
			(1)	(2)	(3)		
6	14568-ZE1-000	SPRING, WEIGHT RETURN .....	1	-	-	-----	BJ,EDE2,EDE2/A,EDK,EDN,EDN2,EDN2/A,EDN5,EDN5/A,EDS,EDS1,EDS1/A,EDS2,EDS2/A,EDS3,EDS4,EDS5,EDS6,EDS6/A,EDT,EDT1/A,EDT1/A,EDT2,EDT3,EDT6,EDT6/A,ED6,ED6/A,ED7,ED8,ED8/A,ED9,ED9/A,EMT,EMT/A,ENT,ENT/A,ENT2,EN6,EN6/A,ES,ES1,ES1/A,ES2,ES3,ES3/A,ES4,ES4/A,ETS,ETX,HA,HAQ,HA2,HA2/A,HH,HX,HX2,HX26,HX26/A,LH,LH/A,LHB1,LHB3,LHB3/A,LHB5,LHC,LHE,LHE/A,LHQ4,LHQ4/A,LHW,LJ,LJ/A,LJG,LJG/A,LJS,LJS/A,LJS1,LKE,LKE/A,LSX,LT,LT/A,LWD,LWD1,LWD1/A,LX,LX/A,LXE,LXE/A,LXE2,LXE2/A,LXE4,LXE4/A,LXE6,LXE8,LXE8/A,LXQ4,LXQ4/A,LXU,LXU/A,LXZ,LX2,LX2/A,LX26,LX26/A,PKT2,PKT2/A,PKT4,PKT4/A,PKX2,PKX4,PKX4/A,PX,PX/A,PXA2,PXE8,PXE8/A,QA,QAB2,QAB2/A,QAC2,QAC2/A,QAE,QAE2,QAE2/A,QAE6,QAE6/A,QAG,QAG/A,QA2,QA2/A,QAH2,QAH2/A,QAP,QAPE,QAP2,QAP2/A,QAQ,QA2,QA2/A,QA26,QA26/A,QDW9,QDW9/A,QE,QE/A,QH,QH/A,QHB3,QHB3/A,QHB5,QHC,QHE,QHE/A,QHP1,QHP1/A,QHQ4,QHQ4/A,QH2,QKA4,QKA4/A,QL2,QMEO,QMEO/A,QME8,QME8/A,QMH,QMH/A,QMT2,QMT2/A,QMX2,QNE,QNE2,QNE2/A,QNE6,QNE9,QNE9/A,QNR2,QNR2/A,QNR6,QNR6/A,QN18,QP,QP/A,QPE2,QT,QT/A,QTC2,QTC2/A,QWH2,QWH2/A,QX,QX/A,QXB,QXB/A,QXB7,QXB7/A,QXC,QXC/A,QXC4,QXC4/A,QXC6,QXC6/A,QXC9,QXC9/A,QXE,QXE/A,QXEB,QXE2,QXE4,QXE4/A,QXE6,QXE6/A,QXE8,QXE8/A,QXQ4,QXQ4/A,QXU,QXU/A,QX2,SDE,SE,SE/A,SH,SH/A,SHB1,SHB3,SHB3/A,SHE,SHEZ,SHQ4,SHQ4/A,SHT,SJ,SJ/A,SJG,SJG/A,SKE,SKE/A,SKZ,SKZ/A,SMEO,SMEO/A,SM2,SM2,SMX2,SMX2/A,STJ,STJ/A,STP,STP/A,STQ,STQ/A,STR,STR/A,SWX,SWX/A,SX,SX/A,SXB,SXB/A,SXB7,SXB7/A,SXE,SXE/A,SXEB,SXEB/A,SXE2,SXE4,SXE4/A,SXE8,SXE8/A,SXP,SXQ4,SXQ4/A,SXU,SXU/A,VA,VAA,VAAE,VAD2,VAD2/A,VAH1,VAH2,VAW1,VA2,VA2/A,VC2,VC2/A,VDE,VDE2,VDE2/A,VD16,VE,VEB6,VH,VHE,VH12,VH12/A,VH22,VH22/A,VMQ,VMT,VMT/A,VMX,VNG,VNG1,VNG2,VSH7,VS2,VS3,VS4,VS5,VS6,VS7,VTE2,VWA,VWA2,VWC,VWC2,VWC2/A,VWE,VWE2,VWE2/A,VWS2,VWS2/A,VW12,VW12/A,VX,VX/A,VXA,VXB,VXB/A,VXB2,VXB7,VXB7/A,VXE,VXE/A,VXEB,VXEB/A,VXE2,VXE2/A,VXE4,VXE6,VXE7,VXE7/A,VXE8,VXE8/A,VXG,VXK,VXQ4,VXQ4/A,VXU,VXU/A,VXU1,VXU1/A,VX16,VX16/A,VX8,VX8/A,YJ,ZK1,ZK1/A
	14568-ZE3-790	.....	-	1	1		
7	14711-ZE3-000	VALVE, IN. ....	1	1	-	-----	LP
	14711-ZE9-900	VALVE, IN. (STELLITE) .....	-	-	1		
8	14721-ZE3-000	VALVE, EX. ....	1	(1)	-		
	14721-ZE3-810	VALVE, EX. (STELLITE) .....	-	(1)	-		
	14721-ZE9-900	.....	-	-	1		
9	14751-ZE2-003	SPRING, VALVE .....	2	2	2		
10	14771-ZE2-000	RETAINER, IN. VALVE SPRING ..	1	1	1		
11	14773-ZE2-000	RETAINER, EX. VALVE SPRING ..	1	1	1		
12	14775-ZE2-010	SEAT, VALVE SPRING .....	1	1	1		
13	14781-ZE2-000	ROTATOR, VALVE .....	1	1	-		
14	14791-ZE2-010	PLATE, PUSH ROD GUIDE .....	1	1	1		
15	90012-ZE0-010	BOLT, PIVOT, 8MM .....	2	2	2		
16	90206-ZE1-000	NUT, PIVOT ADJUSTING .....	2	2	2		



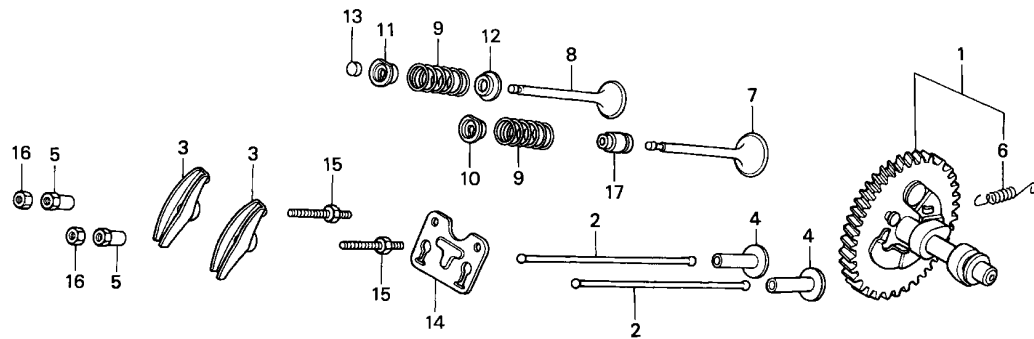

ZK30-E0900



Ref. No.	Part No.	Description	Reqd. QTY			Serial No.	Parts catalogue code
			(1)	(2)	(3)		
17	12209-ZE8-003	SEAL, VALVE STEM .....	1	1	-	-----	EDE2/A,EDK,EDN2/A,EDN5/A,EDS1/A,EDS2/A,EDS4,EDS6/A,EDT/A,EDT1/A,EDT3,EDT6/A,ED6/A,ED8/A,ED9/A,EMT,EMT/A,ENT,ENT/A,ENT2,EN6,EN6/A,ES1/A,ES2,ES3/A,ES4/A,HA2/A,HX26/A,LH/A,LHB3/A,LHB5,LHE/A,LHQ4/A,LJ/A,LJG/A,LJS,LJS/A,LJS1,LKE/A,LT/A,LWD,LWD1/A,LX/A,LXE/A,LXE2/A,LXE4/A,LXE8/A,LXQ4/A,LXU/A,LX2/A,LX26/A,L1/A,PKT2/A,PKT4/A,PKX2,PKX4/A,PX/A,PXA2,PXE8/A,P1/A,QAB2/A,QAC2/A,QAE2/A,QAE6/A,QAG,QAG/A,QA2/A,QAP2/A,QA2,QA26/A,QDW9/A,QE/A,QH/A,QHB3/A,QHB5,QHE/A,QHP1/A,QHQ4/A,QKA4/A,QMEO/A,QME8/A,QMH/A,QMT2/A,QNE2/A,QNE9/A,QNR2/A,QNR6/A,QP/A,QT/A,QTC2/A,QWH2,QWH2/A,QX/A,QXB/A,QXB7,QXB7/A,QXC/A,QXC4/A,QXC6/A,QXC9/A,QXE/A,QXE4/A,QXE6/A,QXE8/A,QXQ4/A,QXU/A,Q1/A,SE/A,SH/A,SHB3/A,SHQ4/A,SJ/A,SJG/A,SKE/A,SKZ/A,SME0/A,SMX2/A,STJ/A,STP/A,STQ/A,STR/A,SWX/A,SX/A,SXB/A,SXB7,SXB7/A,SXE/A,SXEB/A,SXE4/A,SXE8/A,SXQ4/A,SXU/A,S1/A,VAD2/A,VA2/A,VC2,VC2/A,VDE2/A,VH12/A,VH22/A,VMQ,VMT/A,VSH7,VS2,VS3,VS4,VS5,VS6,VS7,VWC,VWC2/A,VWE,VWE2/A,VWS2/A,VW12/A,VX/A,VXB/A,VXB7,VXB7/A,VXE/A,VXEB/A,VXE2/A,VXE7,VXE7/A,VXE8/A,VXK,VXQ4/A,VXU/A,VXU1/A,VX16/A,VX8/A,ZK1/A
			1	1	-	3334264 -----	EDE2,EDN2,EDN5,EDS1,EDS2,EDS6,EDT,EDT1,EDT6,ED6,ED8,ED9,ES1,ES3,ES4,HA2,HX26,LH,LHB3,LHE,LHQ4,LJ,LJG,LKE,LT,LWD1,LX,LXE,LXE2,LXE4,LXE8,LXQ4,LXU,LX2,LX26,L1,PKT2,PKT4,PKX4,PX,PXE8,P1,QAB2,QAC2,QAE2,QAE6,QA2,QA26,QDW9,QE,QH,QHB3,QHE,QHP1,QHQ4,QKA4,QL2,QMEO,QME8,QMH,QMT2,QNE2,QNE9,QNR2,QNR6,QP,QT,QTC2,QX,QXB,QXC,QXC4,QXC6,QXC9,QXE,QXE4,QXE6,QXE8,QXQ4,QXU,Q1,SE,SH,SHB3,SHQ4,SJ,SJG,SKE,SKZ,SME0,SMX2,STJ,STP,STQ,STR,SWX,SX,SXB,SXE,SXEB,SXE4,SXE8,SXQ4,SXU,S1,VAD2,VA2,VDE2,VH12,VH22,VMT,VWC2,VWE2,VWS2,VW12,VX,VXB,VXE,VXEB,VXE2,VXE8,VXQ4,VXU,VXU1,VX16,VX8,ZK1
			-	-	1		

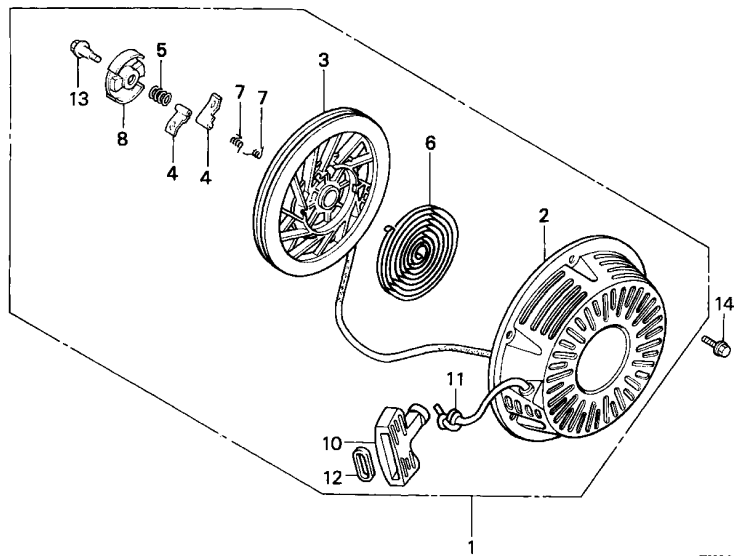

ZK30-E1100

Ref. No.	L.O.N.	(Relative ref. Number) Description	F.R.T.
1	1121B9	STARTER, RECOIL .....	0.1
3	1121B1	REEL, RECOIL STARTER .....	0.3
4	1121B0	RATCHET, STARTER AND/OR SPRING, RATCHET .....	0.2
.NOTE: Same time for two units			
6	1121B7	SPRING, RECOIL STARTER RETURN (5)	0.3
8	1121B2	RETAINER, SPRING .....	0.2
10	1121A3	GRIP, RECOIL STARTER .....	0.1
11	1121B3	ROPE, RECOIL STARTER .....	0.3

Ref. No.	Part No.	Description	Reqd. QTY GX 340K1 (1) (2) (3)	Serial No.	Parts catalogue code
----------	----------	-------------	---	------------	----------------------

1	28400-ZE3-W01ZA	STARTER ASSY., RECOIL *R8*.....BRIGHT RED	1 (1)	-	----- BJ, EDE2, EDS, EDS1, EDS3, EDS6, EDS6/A, EDT1, EDT6, EDT6/A, ED6, ED7, ED8, ED9, EMT, EN, ENT, ES, ES1, ES3, ES4, ET, ETS, ETX, HA, HAQ, HA2, HH, HX, HX2, HX26, LH, LHB1, LHB3, LHC, LHE, LHQ4, LHW, LJ, LJG, LJS, LP, LSX, LT, LX, LXE, LXE2, LXE4, LXE6, LXE8, LXQ4, LXU, LXZ, LX2, LX26, L1, PKT2, PKT4, PKX4, PX, PXE8, P1, QA, QAB2, QAC2, QAE, QAE2, QAE6, QAG, QAH2, QAP, QAPE, QAQ, QA2, QA26, QE, QH, QHB3, QHC, QHE, QHP1, QHQ4, QH2, QKA4, QME0, QME8, QMH, QMT2, QMX2, QNE, QNE2, QNE6, QNE9, QNR2, QNR6, QN18, QP, QT, QTC2, QX, QXB, QXB7, QXC, QXC4, QXC6, QXC9, QXE, QXEB, QXE2, QXE4, QXE6, QXE8, QXQ4, QXU, Q1, SE, SH, SHB1, SHB3, SHE, SHEZ, SHQ4, SHT, SJ, SJG, SKE, SKZ, SME0, SME2, SMX2, STJ, STP, STQ, STR, STR/A, SWX, SX, SXB, SXB7, SXE, SXEB, SXE2, SXE4, SXE8, SXP, SXQ4, SXU, S1, VA, VAA, VAAE, VAD2, VAH1, VAH2, VA2, VC2, VDE, VDE2, VD16, VE, VEB6, VH, VHE, VH12, VH22, VMT, VMX, VNG, VNG1, VNG2, VTE2, VWA, VX, VXA, VXB, VXB2, VXB7, VXE, VXEB, VXE2, VXE4, VXE6, VXE7, VXE8, VXG, VXQ4, VXU, VXU1, VX16, VX8, V1, YJ
---	-----------------	--	-------	---	---



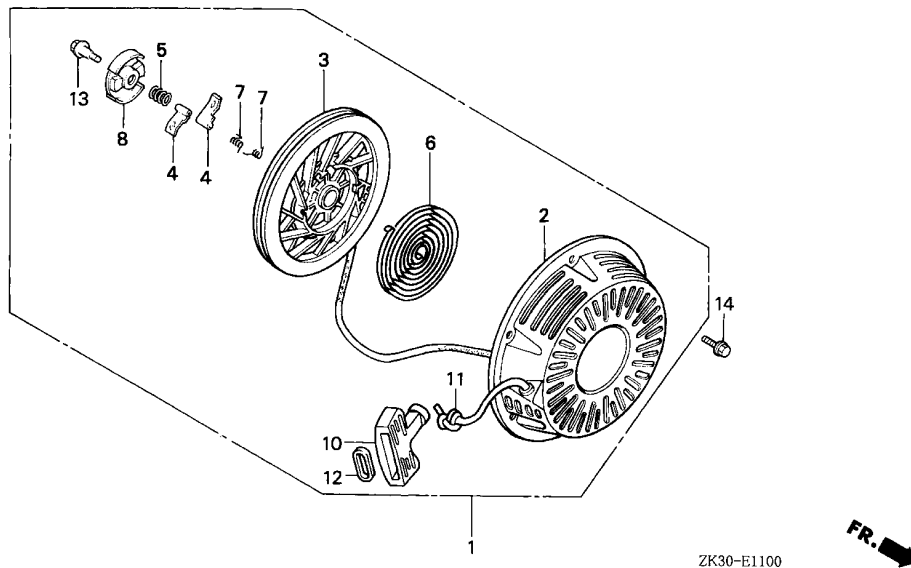

ZK30-E1100



Ref. No.	Part No.	Description	Reqd. QTY			Serial No.	Parts catalogue code
			GX	(1)	(2)		
(1)	28400-ZE3-W01ZA	STARTER ASSY., RECOIL					
	*R8*	.....BRIGHT RED	1	-	-	-----	3658029 PKX2
			1	-	-	-----	3662093 EDE2/A,EDS1/A,EDT1/A,ED6/A,ED8/A,ED9/A,EMT/A,ENT/A,ES1/A,ES3/A,ES4/A,HA2/A,HX26/A,LH/A,LHB3/A,LHB5,LHE/A,LHQ4/A,LJ/A,LJG/A,LJS/A,LT/A,LX/A,LXE/A,LXE2/A,LXE4/A,LXE8/A,LXQ4/A,LXU/A,LX2/A,LX26/A,PKT2/A,PKT4/A,PKX4/A,PX/A,PXE8/A,QAB2/A,QAC2/A,QAE2/A,QAE6/A,QAG/A,QA2/A,QA26/A,QA26/A,QE/A,QH/A,QHB3/A,QHB5,QHE/A,QHP1/A,QHQ4/A,QKA4/A,QME0/A,QME8/A,QMH/A,QMT2/A,QNE2/A,QNE9/A,QNR2/A,QNR6/A,QP/A,QT/A,QTC2/A,QX/A,QXB/A,QXB7/A,QXC/A,QXC4/A,QXC6/A,QXC9/A,QXE/A,QXE4/A,QXE6/A,QXE8/A,QXQ4/A,QXU/A,SE/A,SH/A,SHB3/A,SHQ4/A,SJ/A,SJG/A,SKE/A,SKZ/A,SMEO/A,SMX2/A,STJ/A,STP/A,STQ/A,SWX/A,SX/A,SXB/A,SXB7/A,SXE/A,SXEB/A,SXE4/A,SXE8/A,SXQ4/A,SXU/A,VAD2/A,VA2/A,VC2/A,VDE2/A,VH12/A,VH22/A,VMT/A,VX/A,VXB/A,VXB7/A,VXE/A,VXEB/A,VXE2/A,VXE7/A,VXE8/A,VXQ4/A,VXU/A,VXU1/A,VX16/A,VX8/A
			-	(1)	-	-----	3663624 L1/A,P1/A,Q1/A,S1/A
	28400-ZE3-W01ZB	*NH1*.....BLACK	1	(1)	-	-----	EDE2,EDE2/A,EDK,EDN,EDN2,EDN2/A,EDN5,EDN5/A,EDS1,EDS1/A,EDS2,EDS2/A,EDS3,EDS4,EDS6,EDS6/A,EDT1,EDT1/A,EDT2,EDT3,EDT6,EDT6/A,ED6,ED6/A,ED8,ED8/A,ED9,ED9/A,ENT,ENT/A,ENT2,EN6,EN6/A,ES3/A,ES4/A,HAQ,PKT2/A,PX,PX/A,QAE2,QAE2/A,QAP2,QAP2/A,QAQ,QA2/A,QDW9,QDW9/A,QKA4,QKA4/A,QL2,QMEO,QMEO/A,QMT2,QMT2/A,QMX2,QNE9,QNE9/A,QNR2,QNR2/A,QPE2,QWH2,QWH2/A,QX,QX/A,QXQ4,QXQ4/A,QXU,QXU/A,QX2,Q1,Q1/A,SMEO,SMEO/A,SM2,SMX2,SMX2/A,S1,S1/A,VWC2,VWC2/A
	28400-ZE3-W01ZC	*T34*.....SIMPSON BLUE	1	-	-	-----	QA2,QA2/A
	28400-ZE3-W01ZD	*T39*.....GEKO BLUE	1	-	-	-----	VXE,VXE/A,VXEB,VXEB/A,VXE4
	28400-ZE3-W01ZE	*T41*....BARTELL BLUE METALLIC	1	-	-	-----	QA2,QA2/A,QA26,QA26/A
	28400-ZE3-W01ZH	*NH105*...MAT BLACK (#15-#20)	1	-	-	-----	VAW1,VDE2,VDE2/A,VWA2,VWC,VWC2,VWC2/A,VWE,VWE2,VWE2/A,VWS2,VWS2/A,VW12,VW12/A,VXB7,VXB7/A,VXE,VXE/A,VXE2,VXE2/A,VXE7,VXE7/A

2

Ref. No.	Part No.	Description	Reqd. QTY			Serial No.	Parts catalogue code
			(1)	(2)	(3)		
(1)	28400-ZE3-W01ZK	STARTER ASSY., RECOIL					
		*T68*.....TSURUMI BLUE	1	-	-	-----	EDT,EDT/A,ED6,ED6/A
	28400-ZE3-W01ZL	*Y131*.....LIGHTNING YELLOW	1	-	-	-----	EDE2,EDE2/A,ED6,ED6/A,ENT,ENT/A,ES1,ES1/A,ES3,ES3/A,ES4,ES4/A
	28400-ZE3-W01ZM	*T77*.....SEC WINE RED	1	-	-	-----	ES1,ES1/A,ES3,ES3/A,ES4,ES4/A
	28400-ZE3-W01ZN	*T80*.....BAKELITE ORANGE	1	-	-	-----	ED6,ED6/A,ES3,ES3/A,ES4,ES4/A
	28400-ZE3-W01ZP	*R280*.....POWER RED	1	-	-	-----	EDK,EDS4,EDT3,LJS1,PXA2,VMQ,VSH7,VXK
			1	-	-	3658030	PKX2
			1	-	-	3662094	-----
							EDE2/A,EDS1/A,EDT1/A,ED6/A,ED8/A,ED9/A,EMT/A,ENT/A,ES1/A,ES3/A,ES4/A,HA2/A,HX26/A,LH/A,LHB3/A,LHB5,LHE/A,LHQ4/A,LJ/A,LJG/A,LJS/A,LT/A,LX/A,LXE/A,LXE2/A,LXE4/A,LXE8/A,LXQ4/A,LXU/A,LX2/A,LX26/A,PKT2/A,PKT4/A,PKX4/A,PX/A,PXE8/A,QAB2/A,QAC2/A,QAE2/A,QAE6/A,QAG/A,QA2/A,QA26/A,QA2/A,QA26/A,QE/A,QH/A,QHB3/A,QHB5,QHE/A,QHP1/A,QHQ4/A,QKA4/A,QMEO/A,QME8/A,QMH/A,QMT2/A,QNE2/A,QNE9/A,QNR2/A,QNR6/A,QP/A,QT/A,QTC2/A,QX/A,QXB/A,QXB7/A,QXC/A,QXC4/A,QXC6/A,QXC9/A,QXE/A,QXE4/A,QXE6/A,QXE8/A,QXQ4/A,QXU/A,SE/A,SH/A,SHB3/A,SHQ4/A,SJ/A,SJG/A,SKE/A,SKZ/A,SMEO/A,SMX2/A,STJ/A,STP/A,STQ/A,SWX/A,SX/A,SXB/A,SXB7/A,SXE/A,SXEB/A,SXE4/A,SXE8/A,SXQ4/A,SXU/A,VAD2/A,VA2/A,VC2/A,VDE2/A,VH12/A,VH22/A,VMT/A,VV12/A,VX/A,VXB/A,VXB7/A,VXE/A,VXE8/A,VXE2/A,VXE7/A,VXE8/A,VXQ4/A,VXU/A,VXU1/A,VX16/A,VX8/A
			-	(1)	-	3663625	-----
2	28410-ZE3-W01ZA	CASE COMP., RECOIL STARTER					
		*R8*.....BRIGHT RED	1	(1)	-	-----	BJ,EDE2,EDS,EDS1,EDS3,EDS6,EDS6/A,EDT1,EDT6,EDT6/A,ED6,ED7,ED8,ED9,EMT,EN,ENT,ES,ES1,ES3,ES4,ET,ETS,ETX,HA,HAQ,HA2,HH,HX,HX2,HX26,LH,LHB1,LHB3,LHC,LHE,LHQ4,LHW,LJ,LJG,LJS,LP,LSX,LT,LX,LXE,LXE2,LXE4,LXE6,LXE8,LXQ4,LXU,LXZ,LX2,LX26,L1,PKT2,PKT4,PKX4,PX,PXE8,P1,QA,QAB2,QAC2,QAE,QAE2,QAE6,QAG,QA2,QA26,QA26,QE,QH,QHB3,QHC,QHE,QHP1,QHQ4,QH2,QKA4,QMEO,QME8,QMH,QMT2,QMX2,QNE,QNE2,QNE6,QNE9,QNR2,QNR6,QN18,QP,QT,QTC2,QX,QXB,QXB7,QXC,QXC4,QXC6,QXC9,QXE,QXEB,QXE2,QXE4,QXE6,QXE8,QXQ4,QXU,Q1,SE,SH,SHB1,SHB3,SHE,SHEZ,SHQ4,SHT,SJ,SJG,SKE,SKZ,SMEO,SME2,SMX2,STJ,STP,STQ,STR,STR/A,SWX,SX,SXB,SXB7,SXE,SXEB,SXE2,SXE4,SXE8,SXP,SXQ4,SXU,S1,VA,VAA,VAAE,VAD2,VAH1,VAH2,VA2,VC2,VDE,VDE2,VD16,VE,VEB6,VH,VHE,VH12,VH22,VMT,VMX,VNG,VNG1,VNG2,VTE2,VVA,VX,VXA,VXB,VXB2,VXB7,VXE,VXEB,VXE2,VXE4,VXE6,VXE7,VXE8,VXG,VXQ4,VXU,VXU1,VX16,VX8,V1,YJ
			1	-	-	3658029	PKX2
			1	-	-	3662093	-----
							EDE2/A,EDS1/A,EDT1/A,ED6/A,ED8/A,ED9/A,EMT/A,ENT/A,ES1/A,ES3/A,ES4/A,HA2/A,HX26/A,LH/A,LHB3/A,LHB5,LHE/A,LHQ4/A,LJ/A,LJG/A,LJS/A,LT/A,LX/A,LXE/A,LXE2/A,LXE4/A,LXE8/A,LXQ4/A,LXU/A,LX2/A,LX26/A,PKT2/A,PKT4/A,PKX4/A,PX/A,PXE8/A,QAB2/A,QAC2/A,QAE2/A,QAE6/A,QAG/A,QA2/A,QA26/A,QA2/A,QA26/A,QE/A,QH/A,QHB3/A,QHB5,QHE/A,QHP1/A,QHQ4/A,QKA4/A,QMEO/A,QME8/A,QMH/A,QMT2/A,QNE2/A,QNE9/A,QNR2/A,QNR6/A,QP/A,QT/A,QTC2/A,QX/A,QXB/A,QXB7/A,QXC/A,QXC4/A,QXC6/A,QXC9/A,QXE/A,QXE4/A,QXE6/A,QXE8/A,QXQ4/A,QXU/A,SE/A,SH/A,SHB3/A,SHQ4/A,SJ/A,SJG/A,SKE/A,SKZ/A,SMEO/A,SMX2/A,STJ/A,STP/A,STQ/A,SWX/A,SX/A,SXB/A,SXB7/A,SXE/A,SXEB/A,SXE4/A,SXE8/A,SXQ4/A,SXU/A,VAD2/A,VA2/A,VC2/A,VDE2/A,VH12/A,VH22/A,VMT/A,VX/A,VXB/A,VXB7/A,VXE/A,VXE8/A,VXE2/A,VXE7/A,VXE8/A,VXQ4/A,VXU/A,VXU1/A,VX16/A,VX8/A
			-	(1)	-	3663624	L1/A,P1/A,Q1/A,S1/A
			-	-	1		
	28410-ZE3-W01ZB	*NH1*.....BLACK	1	(1)	-	-----	EDE2,EDE2/A,EDK,EDN,EDN2,EDN2/A,EDN5,EDN5/A,EDS1,EDS1/A,EDS2,EDS2/A,EDS3,EDS4,EDS6,EDS6/A,EDT1,EDT1/A,EDT2,EDT3,EDT6,EDT6/A,ED6,ED6/A,ED8,ED8/A,ED9,ED9/A,ENT,ENT/A,ENT2,EN6,EN6/A,ES3/A,ES4/A,HAQ,PKT2/A,PX,PX/A,QAE2,QAE2/A,QAP2,QAP2/A,QAQ,QA2/A,QDW9,QDW9/A,QKA4,QKA4/A,QL2,QMEO,QMEO/A,QMT2,QMT2/A,QMX2,QNE9,QNE9/A,QNR2,QNR2/A,QPE2,QWH2,QWH2/A,QX,QX/A,QXQ4,QXQ4/A,QXU,QXU/A,QX2,Q1,Q1/A,SMEO,SMEO/A,SME2,SMX2,SMX2/A,S1,S1/A,VWC2,VWC2/A



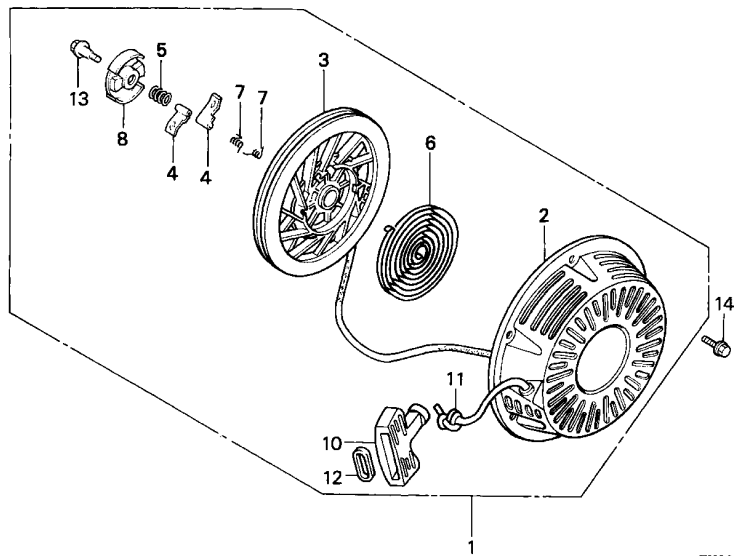

ZK30-E1100



2

Ref. No.	Part No.	Description	Reqd. QTY			Serial No.	Parts catalogue code
			GX	(1)	(2)		
(2)	28410-ZE3-W01ZD	CASE COMP., RECOIL STARTER					
	*T34*	SIMPSON BLUE	1	-	-	QA2,QA2/A,VXE,VXE/A,VXEB,VXEB/A	
	28410-ZE3-W01ZE	*T39* GEKO BLUE	1	-	-	VXE,VXE/A,VXEB,VXEB/A,VXE4	
	28410-ZE3-W01ZF	*T41* BARTELL BLUE METALLIC	1	-	-	QA2,QA2/A,QA26,QA26/A	
	28410-ZE3-W01ZH	*NH105* MAT BLACK (#15-#20)	1	-	-	VAW1,VDE2,VDE2/A,VWA2,VWC,VWC2,VWC2/A,VWE,VWE2,VWE2/A,VWS2,VWS2/A,VW12,VW12/A,VXB7,VXB7/A,VXE,VXE/A,VXE2,VXE2/A,VXE7,VXE7/A	
	28410-ZE3-W01ZK	*T68* TSURUMI BLUE	1	-	-	EDT,EDT/A,ED6,ED6/A	
	28410-ZE3-W01ZL	*Y131* LIGHTNING YELLOW	1	-	-	EDE2,EDE2/A,ED6,ED6/A,ENT,ENT/A,ES1,ES1/A,ES3,ES3/A,ES4,ES4/A	
	28410-ZE3-W01ZM	*T77* SEC WINE RED	1	-	-	ES1,ES1/A,ES3,ES3/A,ES4,ES4/A	
	28410-ZE3-W01ZN	*T80* BAKELITE ORANGE	1	-	-	ED6,ED6/A,ES3,ES3/A,ES4,ES4/A	
	28410-ZE3-W01ZP	*R280* POWER RED	1	-	-	EDK,EDS4,EDT3,LJS1,PXA2,VMQ,VSH7,VXK	
			1	-	-	PKX2	
			1	-	-	3658030	
			1	-	-	3662094	
						EDE2/A,EDS1/A,EDT1/A,ED6/A,ED8/A,ED9/A,EMT/A,ENT/A,ES1/A,ES3/A,ES4/A,HA2/A,HX26/A,LH/A,LHB3/A,LHB5,LHE/A,LHQ4/A,LJ/A,LJG/A,LJS/A,LT/A,LX/A,LXE/A,LXE2/A,LXE4/A,LXE8/A,LXQ4/A,LXU/A,LX2/A,LX26/A,PKT2/A,PKT4/A,PKX4/A,PX/A,PXE8/A,QAB2/A,QAC2/A,QAE2/A,QAE6/A,QAG/A,QA2/A,QAP2/A,QA2/A,QA26/A,QA26/A,QE/A,QH/A,QHB3/A,QHB5,QHE/A,QHP1/A,QHQ4/A,QKA4/A,QME0/A,QME8/A,QMH/A,QMT2/A,QNE2/A,QNE9/A,QNR2/A,QNR6/A,QP/A,QT/A,QTC2/A,QWH2/A,QX/A,QXB/A,QXB7/A,QXC/A,QXC4/A,QXC6/A,QXC9/A,QXE/A,QXE4/A,QXE6/A,QXE8/A,QXQ4/A,QXU/A,SE/A,SH/A,SHB3/A,SHQ4/A,SJ/A,SJG/A,SKE/A,SKZ/A,SMEO/A,SMX2/A,STJ/A,STP/A,STQ/A,SWX/A, SX/A, SXB/A, SXB7/A, SXE/A, SXEB/A, SXE4/A, SXE8/A, SXQ4/A, SXU/A, VAD2/A, VA2/A, VC2/A, VDE2/A, VH12/A, VH22/A, VMT/A, VW12/A, VX/A, VXB7/A, VXE/A, VXE/A, VXE2/A, VXE2/A, VXE7/A, VXE8/A, VXQ4/A, VXU/A, VXU1/A, VX16/A, VX8/A	
			-	1	-	3663625	L1/A,P1/A,Q1/A,S1/A



Ref. No.	Part No.	Description	Reqd. QTY			Serial No.	Parts catalogue code
			GX 340K1 (1)	(2)	(3)		
3	28421-ZE3-W01	PULLEY, RECOIL STARTER .....	1	-	-	-----	BJ,EDE2,EDE2/A,EDK,EDN,EDN2,EDN2/A,EDN5,EDN5/A,EDS,EDS1,EDS1/A,EDS2,EDS2/A,EDS3,EDS4,EDS6,EDS6/A,EDT,EDT/A,EDT1,EDT1/A,EDT2,EDT3,EDT6,EDT6/A,ED6,ED6/A,ED7,ED8,ED8/A,ED9,ED9/A,EMT,EMT/A,EN,ENT,ENT/A,ENT2,EN6,EN6/A,ES,ES1,ES1/A,ES3,ES3/A,ES4,ES4/A,ET,ETS,ETX,HA,HAQ,HA2,HA2/A,HH,HX,HX2,HX26,HX26/A,LH,LH/A,LHB1,LHB3,LHB3/A,LHB5,LHC,LHE,LHE/A,LHQ4,LHQ4/A,LHW,LJ,LJ/A,LJG,LJG/A,LJS,LJS/A,LJS1,LP,LSX,LT,LT/A,LX,LX/A,LXE,LXE/A,LXE2,LXE2/A,LXE4,LXE4/A,LXE6,LXE8,LXE8/A,LXQ4,LXQ4/A,LXU,LXU/A,LXZ,LXZ/A,LX26,LX26/A,PKT2,PKT2/A,PKT4,PKT4/A,PKX2,PKX4,PKX4/A,PX,PX/A,PXA2,PXE8,PXE8/A,QA,QAB2,QAB2/A,QAC2,QAC2/A,QAE,QAE2,QAE2/A,QAE6,QAE6/A,QAG,QAG/A,QA2,QA2/A,QAP,QAPE,QAP2,QAP2/A,QAQ,QA2,QA2/A,QA26,QA26/A,QDW9,QDW9/A,QE,QE/A,QH,QH/A,QHB3,QHB3/A,QHB5,QHC,QHE,QHE/A,QHP1,QHP1/A,QHQ4,QHQ4/A,QHZ,QKA4,QKA4/A,QL2,QMEO,QMEO/A,QME8,QME8/A,QMH,QMH/A,QMT2,QMT2/A,QMX2,QNE,QNE2,QNE2/A,QNE6,QNE9,QNE9/A,QNR2,QNR2/A,QNR6,QNR6/A,QN18,QP,QP/A,QPE2,QT,QT/A,QTC2,QTC2/A,QWH2,QWH2/A,QX,QX/A,QXB,QXB/A,QXB7,QXB7/A,QXC,QXC/A,QXC4,QXC4/A,QXC6,QXC6/A,QXC9,QXC9/A,QXE,QXE/A,QXEB,QXE2,QXE4,QXE4/A,QXE6,QXE6/A,QXE8,QXE8/A,QXQ4,QXQ4/A,QXU,QXU/A,QX2,SE,SE/A,SH,SH/A,SHB1,SHB3,SHB3/A,SHE,SHEZ,SHQ4,SHQ4/A,SHT,SJ,SJ/A,SJG,SJG/A,SKE,SKE/A,SKZ,SKZ/A,SME0,SME0/A,SME2,SMX2,SMX2/A,STJ,STJ/A,STP,STP/A,STQ,STQ/A,STR,STR/A,SWX,SWX/A,SX,SX/A,SXB,SXB/A,SXB7,SXB7/A,SXE,SXE/A,SXEB,SXEB/A,SXE2,SXE4,SXE4/A,SXE8,SXE8/A,SXP,SXQ4,SXQ4/A,SXU,SXU/A,VA,VAE,VAE,VAD2,VAD2/A,VAH1,VAH2,VAW1,VA2,VA2/A,VC2,VC2/A,VDE,VDE2,VDE2/A,VD16,VE,VEB6,VH,VHE,VH12,VH12/A,VH22,VH22/A,VMQ,VMT,VMT/A,VMX,VNG,VNG1,VNG2,VSH7,VTE2,VWA,VWA2,VWC,VWC2,VWC2/A,VWE,VWE2,VWE2/A,VWS2,VWS2/A,VW12,VW12/A,VX,VX/A,VXA,VXB,VXB/A,VXB2,VXB7,VXB7/A,VXE,VXE/A,VXEB,VXEB/A,VXE2,VXE2/A,VXE4,VXE6,VXE7,VXE7/A,VXE8,VXE8/A,VXG,VXK,VXQ4,VXQ4/A,VXU,VXU/A,VXU1,VXU1/A,VX16,VX16/A,VX8,VX8/A,YJ

- (1) 1

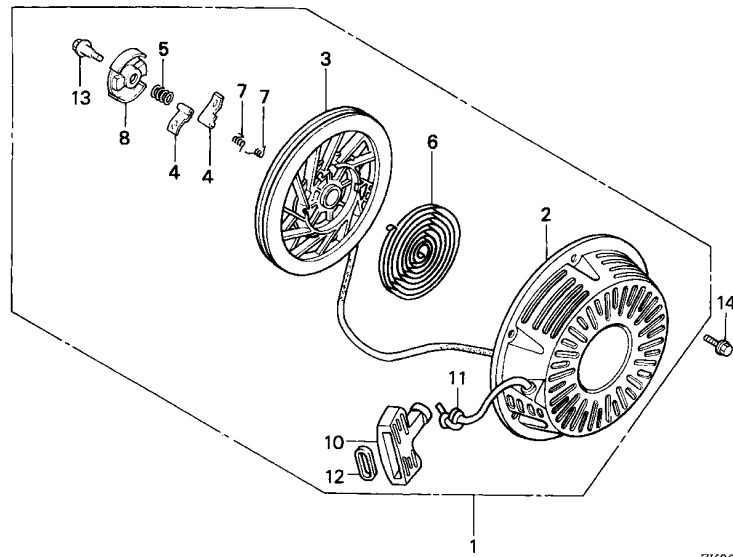

ZK30-E1100



Ref. No.	Part No.	Description	Reqd. QTY			Serial No.	Parts catalogue code
			GX	340K1			
			(1)	(2)	(3)		
4	28422-ZE2-W01	RATCHET, STARTER .....	2	-	-	-----	BJ, EDE2, EDE2/A, EDK, EDN, EDN2, EDN2/A, EDN5, EDN5/A, EDS, EDS1, EDS1/A, EDS2, EDS2/A, EDS3, EDS4, EDS6, EDS6/A, EDT, EDT/A, EDT1, EDT1/A, EDT2, EDT3, EDT6, EDT6/A, ED6, ED6/A, ED7, ED8, ED8/A, ED9, ED9/A, EMT, EMT/A, EN, ENT, ENT/A, ENT2, EN6, EN6/A, ES, ES1, ES1/A, ES3, ES3/A, ES4, ES4/A, ET, ETS, ETX, HA, HAQ, HA2, HA2/A, HH, HX, HX2, HX26, HX26/A, LH, LH/A, LHB1, LHB3, LHB3/A, LHB5, LHC, LHE, LHE/A, LHQ4, LHQ4/A, LHW, LJ, LJ/A, LJG, LJG/A, LJS, LJS/A, LJS1, LP, LSX, LT, LT/A, LX, LX/A, LXE, LXE/A, LXE2, LXE2/A, LXE4, LXE4/A, LXE6, LXE8, LXE8/A, LXQ4, LXQ4/A, LXU, LXU/A, LXZ, LXZ, LX2, LX2/A, LX26, LX26/A, PKT2, PKT2/A, PKT4, PKT4/A, PKX2, PKX4, PKX4/A, PX, PX/A, PXA2, PXE8, PXE8/A, QA, QAB2, QAB2/A, QAC2, QAC2/A, QAE, QAE2, QAE2/A, QAE6, QAE6/A, QAG, QAG/A, QAH2, QAH2/A, QAP, QAPE, QAP2, QAP2/A, QAQ, QA2, QA2/A, QA26, QA26/A, QDW9, QDW9/A, QE, QE/A, QH, QH/A, QHB3, QHB3/A, QHB5, QHC, QHE, QHE/A, QHP1, QHP1/A, QHQ4, QHQ4/A, QH2, QKA4, QKA4/A, QL2, QMED, QMED/A, QME8, QME8/A, QMH, QMH/A, QMT2, QMT2/A, QMX2, QNE, QNE2, QNE2/A, QNE6, QNE9, QNE9/A, QNR2, QNR2/A, QNR6, QNR6/A, QN18, QP, QP/A, QPE2, QT, QT/A, QTC2, QTC2/A, QWH2, QWH2/A, QX, QX/A, QXB, QXB/A, QXB7, QXB7/A, QXC, QXC/A, QXC4, QXC4/A, QXC6, QXC6/A, QXC9, QXC9/A, QXE, QXE/A, QXEB, QXE2, QXE4, QXE4/A, QXE6, QXE6/A, QXE8, QXE8/A, QXQ4, QXQ4/A, QXU, QXU/A, QX2, SE, SE/A, SH, SH/A, SHB1, SHB3, SHB3/A, SHE, SHEZ, SHQ4, SHQ4/A, SHT, SJ, SJ/A, SJG, SJG/A, SKE, SKE/A, SKZ, SKZ/A, SME0, SME0/A, SME2, SMX2, SMX2/A, STJ, STJ/A, STP, STP/A, STQ, STQ/A, STR, STR/A, SWX, SWX/A, SX, SX/A, SXB, SXB/A, SXB7, SXB7/A, SXE, SXE/A, SXEB, SXEB/A, SXE2, SXE4, SXE4/A, SXE8, SXE8/A, SXP, SXQ4, SXQ4/A, SXU, SXU/A, VA, VAA, VAAE, VAD2, VAD2/A, VAH1, VAH2, VAW1, VA2, VA2/A, VC2, VC2/A, VDE, VDE2, VDE2/A, VD16, VE, VEB6, VH, VHE, VH12, VH12/A, VH22, VH22/A, VMQ, VMT, VMT/A, VMX, VNG, VNG1, VNG2, VSH7, VTE2, VVA, VVA2, VVC, VVC2, VVC2/A, VME, VME2, VWE2/A, VWS2, VWS2/A, VW12, VW12/A, VX, VX/A, VXA, VXB, VXB/A, VXB2, VXB7, VXB7/A, VXE, VXE/A, VXE8, VXE8/A, VXE2, VXE2/A, VXE4, VXE4/A, VXE6, VXE6/A, VXE7, VXE7/A, VX8, VX8/A, VVG, VVK, VXQ4, VXQ4/A, VXU, VXU/A, VXU1, VXU1/A, VX16, VX16/A, VX8, VX8/A, YJ

Ref. No.	Part No.	Description	Reqd. QTY			Serial No.	Parts catalogue code
			(1)	(2)	(3)		
(4)	28422-ZE2-W01	RATCHET, STARTER .....	-	(2)	2		
	5 28441-ZE2-W01	SPRING, FRICTION .....	1	-	-	-----	-----
							BJ, EDE2, EDE2/A, EDK, EDN, EDN2, EDN2/A, EDN5, EDN5/A, EDS, EDS1, EDS1/A, EDS2, EDS2/A, EDS3, EDS4, EDS6, EDS6/A, EDT, EDT/A, EDT1, EDT1/A, EDT2, EDT3, EDT6, EDT6/A, ED6, ED6/A, ED7, ED8, ED8/A, ED9, ED9/A, EMT, EMT/A, EN, ENT, ENT/A, ENT2, EN6, EN6/A, ES, ES1, ES1/A, ES3, ES3/A, ES4, ES4/A, ET, ETS, ETX, HA, HAQ, HA2, HA2/A, HH, HX, HX2, HX26, HX26/A, LH, LH/A, LHB1, LHB3, LHB3/A, LHB5, LHC, LHE, LHE/A, LHQ4, LHQ4/A, LHW, LJ, LJ/A, LJG, LJG/A, LJS, LJS/A, LJS1, LP, LSX, LT, LT/A, LX, LX/A, LXE, LXE/A, LXE2, LXE2/A, LXE4, LXE4/A, LXE6, LXE8, LXE8/A, LXQ4, LXQ4/A, LXU, LXU/A, LXZ, LXZ, LX2, LX2/A, LX26, LX26/A, PKT2, PKT2/A, PKT4, PKT4/A, PKX2, PKX4, PKX4/A, PX, PX/A, PXA2, PXE8, PXE8/A, QA, QAB2, QAB2/A, QAC2, QAC2/A, QAE, QAE2, QAE2/A, QAE6, QAE6/A, QAG, QAG/A, QAH2, QAH2/A, QAP, QAPE, QAP2, QAP2/A, QAQ, QA2, QA2/A, QA26, QA26/A, QDW9, QDW9/A, QE, QE/A, QH, QH/A, QHB3, QHB3/A, QHB5, QHC, QHE, QHE/A, QHP1, QHP1/A, QHQ4, QHQ4/A, QH2, QKA4, QKA4/A, QL2, QME0, QME0/A, QME8, QME8/A, QMH, QMH/A, QMT2, QMT2/A, QMX2, QNE, QNE2, QNE2/A, QNE6, QNE9, QNE9/A, QNR2, QNR2/A, QNR6, QNR6/A, QN18, QP, QP/A, QPE2, QT, QT/A, QTC2, QTC2/A, QWH2, QWH2/A, QX, QX/A, QXB, QXB/A, QXB7, QXB7/A, QXC, QXC/A, QXC4, QXC4/A, QXC6, QXC6/A, QXC9, QXC9/A, QXE, QXE/A, QXEB, QXE2, QXE4, QXE4/A, QXE6, QXE6/A, QXE8, QXE8/A, QXQ4, QXQ4/A, QXU, QXU/A, QX2, SE, SE/A, SH, SH/A, SHB1, SHB3, SHB3/A, SHE, SHEZ, SHQ4, SHQ4/A, SHT, SJ, SJ/A, SJG, SJG/A, SKE, SKE/A, SKZ, SKZ/A, SME0, SME0/A, SME2, SMX2, SMX2/A, STJ, STJ/A, STP, STP/A, STQ, STQ/A, STR, STR/A, SWX, SWX/A, SX, SX/A, SXB, SXB/A, SXB7, SXB7/A, SXE, SXE/A, SXEB, SXEB/A, SXE2, SXE4, SXE4/A, SXE8, SXE8/A, SXP, SXQ4, SXQ4/A, SXU, SXU/A, VAA, VAA, VAD2, VAD2/A, VAH1, VAH2, VAW1, VA2, VA2/A, VC2, VC2/A, VDE, VDE2, VDE2/A, VD16, VE, VEB6, VH, VHE, VH12, VH12/A, VH22, VH22/A, VMQ, VMT, VMT/A, VMX, VNG, VNG1, VNG2, VSH7, VTE2, VWA, VWA2, VWC, VWC2, VWC2/A, VWE, VWE2, VWE2/A, VWS2, VWS2/A, VW12, VW12/A, VX, VX/A, VXA, VXB, VXB/A, VXB2, VXB7, VXB7/A, VXE, VXE/A, VXEB, VXEB/A, VXE2, VXE2/A, VXE4, VXE6, VXE7, VXE7/A, VXE8, VXE8/A, VXG, VXX, VXQ4, VXQ4/A, VXU, VXU/A, VXU1, VXU1/A, VX16, VX16/A, VX8, VX8/A, YY
			-	(1)	1		



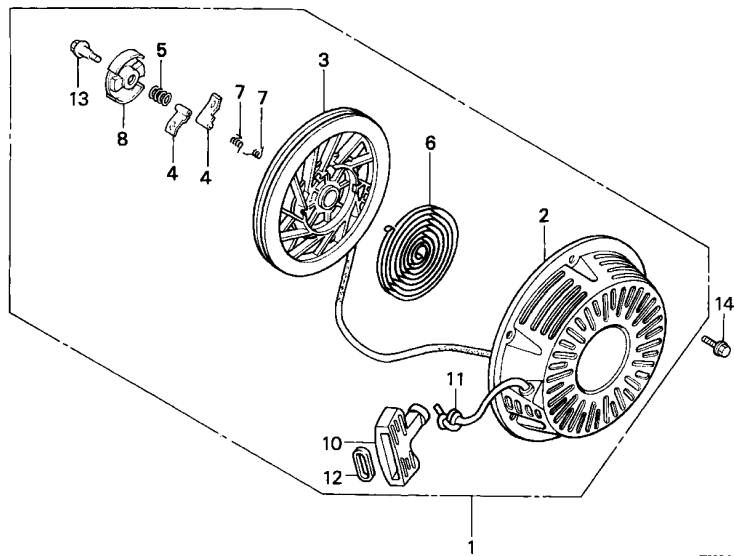

ZK30-E1100



Ref. No.	Part No.	Description	Reqd. QTY			Serial No.	Parts catalogue code
			GX	340K1			
			(1)	(2)	(3)		
6	28442-ZE2-W01	SPRING, STARTER RETURN .....	1	-	-	-----	BJ, EDE2, EDE2/A, EDK, EDN, EDN2, EDN2/A, EDN5, EDN5/A, EDS, EDS1, EDS1/A, EDS2, EDS2/A, EDS3, EDS4, EDS6, EDS6/A, EDT, EDT/A, EDT1, EDT1/A, EDT2, EDT3, EDT6, EDT6/A, ED6, ED6/A, ED7, ED8, ED8/A, ED9, ED9/A, EMT, EMT/A, EN, ENT, ENT/A, ENT2, EN6, EN6/A, ES, ES1, ES1/A, ES3, ES3/A, ES4, ES4/A, ET, ETS, ETX, HA, HAQ, HA2, HA2/A, HH, HX, HX2, HX26, HX26/A, LH, LH/A, LHB1, LHB3, LHB3/A, LHB5, LHC, LHE, LHE/A, LHQ4, LHQ4/A, LHW, LJ, LJ/A, LJG, LJG/A, LJS, LJS/A, LJS1, LP, LSX, LT, LT/A, LX, LX/A, LXE, LXE/A, LXE2, LXE2/A, LXE4, LXE4/A, LXE6, LXE8, LXE8/A, LXQ4, LXQ4/A, LXU, LXU/A, LXZ, LXZ, LX2, LX2/A, LX26, LX26/A, PKT2, PKT2/A, PKT4, PKT4/A, PKX2, PKX4, PKX4/A, PX, PX/A, PXA2, PXE8, PXE8/A, QA, QAB2, QAB2/A, QAC2, QAC2/A, QAE, QAE2, QAE2/A, QAE6, QAE6/A, QAG, QAG/A, QAH2, QAH2/A, QAP, QAPE, QAP2, QAP2/A, QAQ, QA2, QA2/A, QA26, QA26/A, QDW9, QDW9/A, QE, QE/A, QH, QH/A, QHB3, QHB3/A, QHB5, QHC, QHE, QHE/A, QHP1, QHP1/A, QHQ4, QHQ4/A, QH2, QKA4, QKA4/A, QL2, QMED, QMED/A, QME8, QME8/A, QMH, QMH/A, QMT2, QMT2/A, QMX2, QNE, QNE2, QNE2/A, QNE6, QNE9, QNE9/A, QNR2, QNR2/A, QNR6, QNR6/A, QN18, QP, QP/A, QPE2, QT, QT/A, QTC2, QTC2/A, QWH2, QWH2/A, QX, QX/A, QXB, QXB/A, QXB7, QXB7/A, QXC, QXC/A, QXC4, QXC4/A, QXC6, QXC6/A, QXC9, QXC9/A, QXE, QXE/A, QXEB, QXE2, QXE4, QXE4/A, QXE6, QXE6/A, QXE8, QXE8/A, QXQ4, QXQ4/A, QXU, QXU/A, QX2, SE, SE/A, SH, SH/A, SHB1, SHB3, SHB3/A, SHE, SHEZ, SHQ4, SHQ4/A, SHT, SJ, SJ/A, SJG, SJG/A, SKE, SKE/A, SKZ, SKZ/A, SME0, SME0/A, SME2, SMX2, SMX2/A, STJ, STJ/A, STP, STP/A, STQ, STQ/A, STR, STR/A, SWX, SWX/A, SX, SX/A, SXB, SXB/A, SXB7, SXB7/A, SXE, SXE/A, SXEB, SXEB/A, SXE2, SXE4, SXE4/A, SXE8, SXE8/A, SXP, SXQ4, SXQ4/A, SXU, SXU/A, VA, VAA, VAAE, VAD2, VAD2/A, VAH1, VAH2, VAW1, VA2, VA2/A, VC2, VC2/A, VDE, VDE2, VDE2/A, VD16, VE, VEB6, VH, VHE, VH12, VH12/A, VH22, VH22/A, VMQ, VMT, VMT/A, VMX, VNG, VNG1, VNG2, VSH7, VTE2, VVA, VVA2, VVC, VVC2, VVC2/A, VME, VME2, VWE2/A, VWS2, VWS2/A, VW12, VW12/A, VX, VX/A, VXA, VXB, VXB/A, VXB2, VXB7, VXB7/A, VXE, VXE/A, VXE8, VXE8/A, VXE2, VXE2/A, VXE4, VXE4/A, VXE6, VXE6/A, VXE7, VXE7/A, VXE8, VXE8/A, VXG, VXX, VXQ4, VXQ4/A, VXU, VXU/A, VXU1, VXU1/A, VX16, VX16/A, VX8, VX8/A, YJ

Ref. No.	Part No.	Description	Reqd. QTY			Serial No.	Parts catalogue code
			(1)	(2)	(3)		
(6)	28442-ZE2-W01	SPRING, STARTER RETURN .....	-	(1)	1		
	7 28443-ZE2-W01	SPRING, RATCHET .....	2	-	-	-----	----- BJ, EDE2, EDE2/A, EDK, EDN, EDN2, EDN2/A, EDN5, EDN5/A, EDS, EDS1, EDS1/A, EDS2, EDS2/A, EDS3, EDS4, EDS6, EDS6/A, EDT, EDT/A, EDT1, EDT1/A, EDT2, EDT3, EDT6, EDT6/A, ED6, ED6/A, ED7, ED8, ED8/A, ED9, ED9/A, EMT, EMT/A, EN, ENT, ENT/A, ENT2, EN6, EN6/A, ES, ES1, ES1/A, ES3, ES3/A, ES4, ES4/A, ET, ETS, ETX, HA, HAQ, HA2, HA2/A, HH, HX, HX2, HX26, HX26/A, LH, LH/A, LHB1, LHB3, LHB3/A, LHB5, LHC, LHE, LHE/A, LHQ4, LHQ4/A, LHW, LJ, LJ/A, LJG, LJG/A, LJS, LJS/A, LJS1, LP, LSX, LT, LT/A, LX, LX/A, LXE, LXE/A, LXE2, LXE2/A, LXE4, LXE4/A, LXE6, LXE8, LXE8/A, LXQ4, LXQ4/A, LXU, LXU/A, LXZ, LX2, LX2/A, LX26, LX26/A, PKT2, PKT2/A, PKT4, PKT4/A, PKX2, PKX4, PKX4/A, PX, PX/A, PXA2, PXE8, PXE8/A, QA, QAB2, QAB2/A, QAC2, QAC2/A, QAE, QAE2, QAE2/A, QAE6, QAE6/A, QAG, QAG/A, QAH2, QAH2/A, QAP, QAPE, QAP2, QAP2/A, QAQ, QA2, QA2/A, QA26, QA26/A, QDW9, QDW9/A, QE, QE/A, QH, QH/A, QHB3, QHB3/A, QHB5, QHC, QHE, QHE/A, QHP1, QHP1/A, QHQ4, QHQ4/A, QH2, QKA4, QKA4/A, QL2, QMEO, QMEO/A, QME8, QME8/A, QMH, QMH/A, QMT2, QMT2/A, QMX2, QNE, QNE2, QNE2/A, QNE6, QNE9, QNE9/A, QNR2, QNR2/A, QNR6, QNR6/A, QN18, QP, QP/A, QPE2, QT, QT/A, QTC2, QTC2/A, QWH2, QWH2/A, QX, QX/A, QXB, QXB/A, QXB7, QXB7/A, QXC, QXC/A, QXC4, QXC4/A, QXC6, QXC6/A, QXC9, QXC9/A, QXE, QXE/A, QXEB, QXE2, QXE4, QXE4/A, QXE6, QXE6/A, QXE8, QXE8/A, QXQ4, QXQ4/A, QXU, QXU/A, QX2, SE, SE/A, SH, SH/A, SHB1, SHB3, SHB3/A, SHE, SHEZ, SHQ4, SHQ4/A, SHT, SJ, SJ/A, SJG, SJG/A, SKE, SKE/A, SKZ, SKZ/A, SME0, SME0/A, SME2, SMX2, SMX2/A, STJ, STJ/A, STP, STP/A, STQ, STQ/A, STR, STR/A, SWX, SWX/A, SX, SX/A, SXB, SXB/A, SXB7, SXB7/A, SXE, SXE/A, SXEB, SXEB/A, SXE2, SXE4, SXE4/A, SXE8, SXE8/A, SXP, SXQ4, SXQ4/A, SXU, SXU/A, VA, VAA, VAAE, VAD2, VAD2/A, VAH1, VAH2, VAW1, VA2, VA2/A, VC2, VC2/A, VDE, VDE2, VDE2/A, VD16, VE, VEB6, VH, VHE, VH12, VH12/A, VH22, VH22/A, VMQ, VMT, VMT/A, VMX, VNG, VNG1, VNG2, VSH7, VTE2, VWA, VWA2, VWC, VWC2, VWC2/A, VWE, VWE2, VWE2/A, VWS2, VWS2/A, VW12, VW12/A, VX, VX/A, VXA, VXB, VXB/A, VXB2, VXB7, VXB7/A, VXE, VXE/A, VXEB, VXEB/A, VXE2, VXE2/A, VXE4, VXE6, VXE7, VXE7/A, VXE8, VXE8/A, VXG, VXX, VXQ4, VXQ4/A, VXU, VXU/A, VXU1, VXU1/A, VX16, VX16/A, VX8, VX8/A, YY
			-	(2)	2		



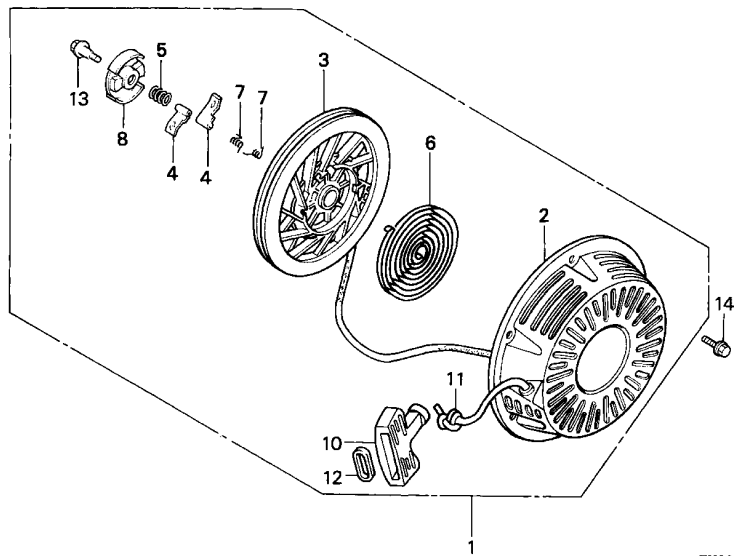

ZK30-E1100



Ref. No.	Part No.	Description	Reqd. QTY			Serial No.	Parts catalogue code
			GX	340K1			
			(1)	(2)	(3)		
8	28444-ZE2-W01	RETAINER, SPRING .....	1	-	-	-----	BJ, EDE2, EDE2/A, EDK, EDN, EDN2, EDN2/A, EDN5, EDN5/A, EDS, EDS1, EDS1/A, EDS2, EDS2/A, EDS3, EDS4, EDS6, EDS6/A, EDT, EDT/A, EDT1, EDT1/A, EDT2, EDT3, EDT6, EDT6/A, ED6, ED6/A, ED7, ED8, ED8/A, ED9, ED9/A, EMT, EMT/A, EN, ENT, ENT/A, ENT2, EN6, EN6/A, ES, ES1, ES1/A, ES3, ES3/A, ES4, ES4/A, ET, ETS, ETX, HA, HAQ, HA2, HA2/A, HH, HX, HX2, HX26, HX26/A, LH, LH/A, LHB1, LHB3, LHB3/A, LHB5, LHC, LHE, LHE/A, LHQ4, LHQ4/A, LHW, LJ, LJ/A, LJG, LJG/A, LJS, LJS/A, LJS1, LP, LSX, LT, LT/A, LX, LX/A, LXE, LXE/A, LXE2, LXE2/A, LXE4, LXE4/A, LXE6, LXE8, LXE8/A, LXQ4, LXQ4/A, LXU, LXU/A, LXZ, LXZ, LX2, LX2/A, LX26, LX26/A, PKT2, PKT2/A, PKT4, PKT4/A, PKX2, PKX4, PKX4/A, PX, PX/A, PXA2, PXE8, PXE8/A, QA, QAB2, QAB2/A, QAC2, QAC2/A, QAE, QAE2, QAE2/A, QAE6, QAE6/A, QAG, QAG/A, QAH2, QAH2/A, QAP, QAPE, QAP2, QAP2/A, QAQ, QA2, QA2/A, QA26, QA26/A, QDW9, QDW9/A, QE, QE/A, QH, QH/A, QHB3, QHB3/A, QHB5, QHC, QHE, QHE/A, QHP1, QHP1/A, QHQ4, QHQ4/A, QH2, QKA4, QKA4/A, QL2, QMED, QMED/A, QME8, QME8/A, QMH, QMH/A, QMT2, QMT2/A, QMX2, QNE, QNE2, QNE2/A, QNE6, QNE9, QNE9/A, QNR2, QNR2/A, QNR6, QNR6/A, QN18, QP, QP/A, QPE2, QT, QT/A, QTC2, QTC2/A, QWH2, QWH2/A, QX, QX/A, QXB, QXB/A, QXB7, QXB7/A, QXC, QXC/A, QXC4, QXC4/A, QXC6, QXC6/A, QXC9, QXC9/A, QXE, QXE/A, QXEB, QXE2, QXE4, QXE4/A, QXE6, QXE6/A, QXE8, QXE8/A, QXQ4, QXQ4/A, QXU, QXU/A, QX2, SE, SE/A, SH, SH/A, SHB1, SHB3, SHB3/A, SHE, SHEZ, SHQ4, SHQ4/A, SHT, SJ, SJ/A, SJG, SJG/A, SKE, SKE/A, SKZ, SKZ/A, SME0, SME0/A, SME2, SMX2, SMX2/A, STJ, STJ/A, STP, STP/A, STQ, STQ/A, STR, STR/A, SWX, SWX/A, SX, SX/A, SXB, SXB/A, SXB7, SXB7/A, SXE, SXE/A, SXEB, SXEB/A, SXE2, SXE4, SXE4/A, SXE8, SXE8/A, SXP, SXQ4, SXQ4/A, SXU, SXU/A, VA, VAA, VAAE, VAD2, VAD2/A, VAH1, VAH2, VAW1, VA2, VA2/A, VC2, VC2/A, VDE, VDE2, VDE2/A, VD16, VE, VEB6, VH, VHE, VH12, VH12/A, VH22, VH22/A, VMQ, VMT, VMT/A, VMX, VNG, VNG1, VNG2, VSH7, VTE2, VVA, VVA2, VVC, VVC2, VVC2/A, VME, VME2, VWE2/A, VWS2, VWS2/A, VW12, VW12/A, VX, VX/A, VXA, VXB, VXB/A, VXB2, VXB7, VXB7/A, VXE, VXE/A, VXE8, VXE8/A, VXE2, VXE2/A, VXE4, VXE4/A, VXE6, VXE6/A, VXE7, VXE7/A, VXE8, VXE8/A, VXG, VXX, VXQ4, VXQ4/A, VXU, VXU/A, VXU1, VXU1/A, VX16, VX16/A, VX8, VX8/A, YJ

Ref. No.	Part No.	Description	Reqd. QTY			Serial No.	Parts catalogue code
			(1)	(2)	(3)		
(8)	28444-ZE2-W01	RETAINER, SPRING .....	-	(1)	1		
10	28461-ZE2-W01	GRIP, STARTER .....	1	(1)	-	2935312	BJ, EDE2, EDN, EDN2, EDN5, EDS, EDS1, EDS2, EDS3, EDS6, EDT, EDT1, EDT2, EDT6, ED6, ED7, ED8, ED9, EMT, EN, ENT, EN6, ES, ES1, ES3, ES4, ET, ETS, ETX, HA, HAQ, HA2, HH, HX, HX2, HX26, LH, LHB1, LHB3, LHC, LHE, LHQ4, LHW, LJ, LJG, LJS, LP, LSX, LT, LX, LXE, LXE2, LXE4, LXE6, LXE8, LXQ4, LXU, LXZ, LX2, LX26, L1, PKT2, PKT4, PKX4, PX, PXE8, P1, QA, QAB2, QAC2, QAE, QAE2, QAE6, QAG, QAH2, QAP, QAPE, QAP2, QAA, QA2, QA26, QDW9, QE, QH, QHB3, QHC, QHE, QHP1, QHQ4, QH2, QKA4, QL2, QME0, QME8, QMH, QMT2, QMX2, QNE, QNE2, QNE6, QNE9, QNR2, QNR6, QN18, QP, QPE2, QT, QTC2, QWH2, QX, QXB, QXB7, QXC, QXC4, QXC6, QXC9, QXE, QXE6, QXE2, QXE4, QXE8, QXQ4, QXU, QX2, Q1, SE, SH, SHB1, SHB3, SHE, SHEZ, SHQ4, SHT, SJ, SJG, SKE, SKZ, SME0, SME2, SMX2, STJ, STP, STQ, STR, SWX, SX, SXB, SXB7, SXE, SXEB, SXE2, SXE4, SXE8, SXP, SXQ4, SXU, S1, VA, VAA, VAAE, VAD2, VAH1, VAH2, VAW1, VA2, VC2, VDE, VDE2, VD16, VE, VEB6, VH, VHE, VH12, VH22, VMT, VMX, VNG, VNG1, VNG2, VTE2, VWA, VWA2, VWC2, VWE2, VWS2, VW12, VX, VXA, VXB, VXB2, VXB7, VXE, VXEB, VXE2, VXE4, VXE6, VXE7, VXE8, VXG, VXQ4, VXU, VXU1, VX16, VX8, V1, YJ
	28461-ZE2-W02	.....	-	-	1		
			1	(1)	-	2935313	EDE2/A, EDK, EDN2/A, EDN5/A, EDS1/A, EDS2/A, EDS4, EDS6/A, EDT/A, EDT1/A, EDT3, EDT6/A, ED6/A, ED8/A, ED9/A, EMT/A, ENT/A, ENT2, EN6/A, ES1/A, ES3/A, ES4/A, HA2/A, HX26/A, LH/A, LHB3/A, LHB5, LHE/A, LHQ4/A, LJ/A, LJG/A, LJS/A, LJS1, LT/A, LX/A, LXE/A, LXE2/A, LXE4/A, LXE8/A, LXQ4/A, LXU/A, LX2/A, LX26/A, L1/A, PKT2/A, PKT4/A, PKX2, PKX4/A, PX/A, PXA2, PXE8/A, P1/A, QAB2/A, QAC2/A, QAE2/A, QAE6/A, QAG/A, QAH2/A, QAP2/A, QA2/A, QA26/A, QDW9/A, QE/A, QH/A, QHB3/A, QHB5, QHE/A, QHP1/A, QHQ4/A, QKA4/A, QME0/A, QME8/A, QMH/A, QMT2/A, QNE2/A, QNE9/A, QNR2/A, QNR6/A, QP/A, QT/A, QTC2/A, QWH2/A, QX/A, QXB/A, QXB7/A, QXC/A, QXC4/A, QXC6/A, QXC9/A, QXE/A, QXE4/A, QXE6/A, QXE8/A, QXQ4/A, QXU/A, Q1/A, SE/A, SH/A, SHB3/A, SHQ4/A, SJ/A, SJG/A, SKE/A, SKZ/A, SME0/A, SMX2/A, STJ/A, STP/A, STQ/A, STR/A, SWX/A, SX/A, SXB/A, SXB7/A, SXE/A, SXEB/A, SXE4/A, SXE8/A, SXQ4/A, SXU/A, S1/A, VAD2/A, VA2/A, VC2/A, VDE2/A, VH12/A, VH22/A, VMQ, VMT/A, VSH7, VWC, VWC2/A, VWE, VWE2/A, VWS2/A, VW12/A, VX/A, VXB/A, VXB7/A, VXE/A, VXEB/A, VXE2/A, VXE7/A, VXE8/A, VXX, VXQ4/A, VXU/A, VXU1/A, VX16/A, VX8/A
			1	(1)	-	2935313	BJ, EDE2, EDN, EDN2, EDN5, EDS, EDS1, EDS2, EDS3, EDS6, EDT, EDT1, EDT2, EDT6, ED6, ED7, ED8, ED9, EMT, EN, ENT, EN6, ES, ES1, ES3, ES4, ET, ETS, ETX, HA, HAQ, HA2, HH, HX, HX2, HX26, LH, LHB1, LHB3, LHC, LHE, LHQ4, LHW, LJ, LJG, LJS, LP, LSX, LT, LX, LXE, LXE2, LXE4, LXE6, LXE8, LXQ4, LXU, LXZ, LX2, LX26, L1, PKT2, PKT4, PKX4, PX, PXE8, P1, QA, QAB2, QAC2, QAE, QAE2, QAE6, QAG, QAH2, QAP, QAPE, QAP2, QAA, QA2, QA26, QDW9, QE, QH, QHB3, QHC, QHE, QHP1, QHQ4, QH2, QKA4, QL2, QME0, QME8, QMH, QMT2, QMX2, QNE, QNE2, QNE6, QNE9, QNR2, QNR6, QN18, QP, QPE2, QT, QTC2, QWH2, QX, QXB, QXB7, QXC, QXC4, QXC6, QXC9, QXE, QXE6, QXE2, QXE4, QXE8, QXQ4, QXU, QX2, Q1, SE, SH, SHB1, SHB3, SHE, SHEZ, SHQ4, SHT, SJ, SJG, SKE, SKZ, SME0, SME2, SMX2, STJ, STP, STQ, STR, SWX, SX, SXB, SXB7, SXE, SXEB, SXE2, SXE4, SXE8, SXP, SXQ4, SXU, S1, VA, VAA, VAAE, VAD2, VAH1, VAH2, VAW1, VA2, VC2, VDE, VDE2, VD16, VE, VEB6, VH, VHE, VH12, VH22, VMT, VMX, VNG, VNG1, VNG2, VTE2, VWA, VWA2, VWC2, VWE2, VWS2, VW12, VX, VXA, VXB, VXB2, VXB7, VXE, VXEB, VXE2, VXE4, VXE6, VXE7, VXE8, VXG, VXQ4, VXU, VXU1, VX16, VX8, V1, YJ



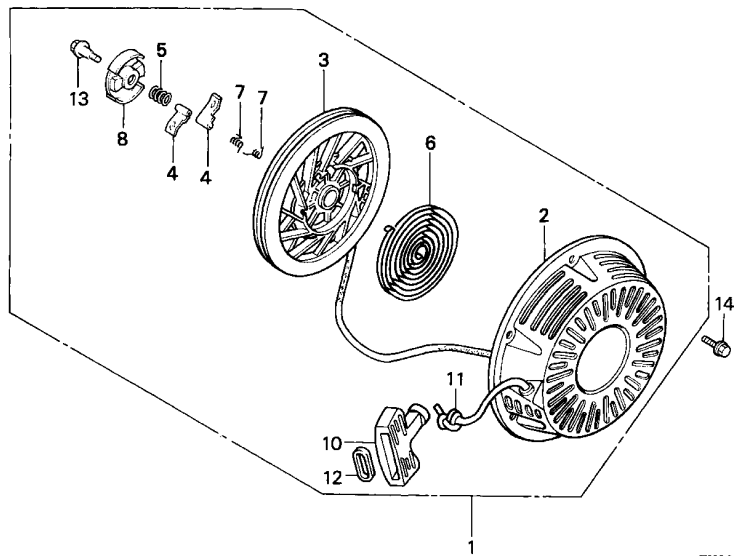

ZK30-E1100



Ref. No.	Part No.	Description	Reqd. QTY			Serial No.	Parts catalogue code
			GX	(1)	(2)		
11	28462-ZE3-W01	ROPE, RECOIL STARTER .....	1	-	-	-	BJ, EDE2, EDE2/A, EDK, EDN, EDN2, EDN2/A, EDN5, EDN5/A, EDS, EDS1, EDS1/A, EDS2, EDS2/A, EDS3, EDS4, EDS6, EDS6/A, EDT, EDT/A, EDT1, EDT1/A, EDT2, EDT3, EDT6, EDT6/A, ED6, ED6/A, ED7, ED8, ED8/A, ED9, ED9/A, EMT, EMT/A, EN, ENT, ENT/A, ENT2, EN6, EN6/A, ES, ES1, ES1/A, ES3, ES3/A, ES4, ES4/A, ET, ETS, ETX, HA, HAQ, HA2, HA2/A, HH, HX, HX2, HX26, HX26/A, LH, LH/A, LHB1, LHB3, LHB3/A, LHB5, LHC, LHE, LHE/A, LHQ4, LHQ4/A, LHW, LJ, LJ/A, LJG, LJG/A, LJS, LJS/A, LJS1, LP, LSX, LT, LT/A, LX, LX/A, LXE, LXE/A, LXE2, LXE2/A, LXE4, LXE4/A, LXE6, LXE8, LXE8/A, LXQ4, LXQ4/A, LXU, LXU/A, LXZ, LXZ, LX2, LX2/A, LX26, LX26/A, PKT2, PKT2/A, PKT4, PKT4/A, PKX2, PKX4, PKX4/A, PX, PX/A, PXA2, PXE8, PXE8/A, QA, QAB2, QAB2/A, QAC2, QAC2/A, QAE, QAE2, QAE2/A, QAE6, QAE6/A, QAG, QAG/A, QAH2, QAH2/A, QAP, QAPE, QAP2, QAP2/A, QAQ, QA2, QA2/A, QA26, QA26/A, QDW9, QDW9/A, QE, QE/A, QH, QH/A, QHB3, QHB3/A, QHB5, QHC, QHE, QHE/A, QHP1, QHP1/A, QHQ4, QHQ4/A, QH2, QKA4, QKA4/A, QL2, QMED, QMED/A, QME8, QME8/A, QMH, QMH/A, QMT2, QMT2/A, QMX2, QNE, QNE2, QNE2/A, QNE6, QNE9, QNE9/A, QNR2, QNR2/A, QNR6, QNR6/A, QN18, QP, QP/A, QPE2, QT, QT/A, QTC2, QTC2/A, QWH2, QWH2/A, QX, QX/A, QXB, QXB/A, QXB7, QXB7/A, QXC, QXC/A, QXC4, QXC4/A, QXC6, QXC6/A, QXC9, QXC9/A, QXE, QXE/A, QXEB, QXE2, QXE4, QXE4/A, QXE6, QXE6/A, QXE8, QXE8/A, QXQ4, QXQ4/A, QXU, QXU/A, QX2, SE, SE/A, SH, SH/A, SHB1, SHB3, SHB3/A, SHE, SHEZ, SHQ4, SHQ4/A, SHT, SJ, SJ/A, SJG, SJG/A, SKE, SKE/A, SKZ, SKZ/A, SME0, SME0/A, SME2, SMX2, SMX2/A, STJ, STJ/A, STP, STP/A, STQ, STQ/A, STR, STR/A, SWX, SWX/A, SX, SX/A, SXB, SXB/A, SXB7, SXB7/A, SXE, SXE/A, SXEB, SXEB/A, SXE2, SXE4, SXE4/A, SXE8, SXE8/A, SXP, SXQ4, SXQ4/A, SXU, SXU/A, VA, VAA, VAAE, VAD2, VAD2/A, VAH1, VAH2, VAW1, VA2, VA2/A, VC2, VC2/A, VDE, VDE2, VDE2/A, VD16, VE, VEB6, VH, VHE, VH12, VH12/A, VH22, VH22/A, VMQ, VMT, VMT/A, VMX, VNG, VNG1, VNG2, VSH7, VTE2, VVA, VVA2, VVC, VVC2, VVC2/A, VME, VME2, VME2/A, VWS2, VWS2/A, VW12, VW12/A, VX, VX/A, VXA, VXB, VXB/A, VXB2, VXB7, VXB7/A, VXE, VXE/A, VXE8, VXE8/A, VXE2, VXE2/A, VXE4, VXE4/A, VXE6, VXE6/A, VXE7, VXE7/A, VXE8, VXE8/A, VXG, VXX, VXQ4, VXQ4/A, VXU, VXU/A, VXU1, VXU1/A, VX16, VX16/A, VX8, VX8/A, YJ



Ref. No.	Part No.	Description	Reqd. QTY			Serial No.	Parts catalogue code
			(1)	(2)	(3)		
11)	28462-ZE3-W01	ROPE, RECOIL STARTER .....	-	(1)	1		
12	28469-ZE2-W01	GRIP, REINFORCEMENT .....	1	(1)	-	----- 2935312	BJ, EDE2, EDN, EDN2, EDN5, EDS, EDS1, EDS2, EDS3, EDT1, EDT2, ED6, ED7, ED8, ED9, EN, ES, ES1, ES3, ES4, ET, ETS, ETX, HA, HAQ, HA2, HH, HX, HX2, HX26, LH, LHB1, LHB3, LHC, LHE, LHQ4, LHW, LJ, LJG, LP, LSX, LX, LXE, LXE2, LXE4, LXE6, LXE8, LXQ4, LXU, LXZ, LX2, LX26, L1, PKT2, PKT4, PKX4, PX, PXE8, P1, QA, QAE, QAE2, QAE6, QAH2, QAP, QAPE, QAP2, QAA, QA2, QA26, QDW9, QE, QH, QHB3, QHC, QHE, QHP1, QHQ4, QH2, QKA4, QMEO, QME8, QMH, QMT2, QMX2, QNE, QNE2, QNE6, QNE9, QNR2, QNR6, QN18, QP, QPE2, QT, QTC2, QX, QXB, QXC, QXC4, QXC6, QXC9, QXE, QXEB, QXE2, QXE4, QXE6, QXE8, QXQ4, QXU, QX2, Q1, SE, SH, SHB1, SHB3, SHE, SHEZ, SHQ4, SHT, SJ, SJG, SKE, SKZ, SMEO, SME2, SMX2, STJ, STP, STQ, STR, SWX, SX, SXB, SXE, SXEB, SXE2, SXE4, SXE8, SXP, SXQ4, SXU, S1, VA, VAA, VAAE, VAD2, VAH1, VAH2, VAW1, VA2, VDE, VDE2, VD16, VE, VEB6, VH, VHE, VH12, VH22, VMX, VNG, VNG1, VNG2, VTE2, VWA, VWA2, VWC2, VWE2, VWS2, VW12, VX, VXA, VXB, VXB2, VXE, VXE6, VXE8, VXE2, VXE4, VXE8, VXG, VXQ4, VXU, VXU1, VX16, VX8, V1, YJ
13	90004-ZE2-W01	SCREW, CENTER .....	1	-	1	-----	BJ, EDE2, EDE2/A, EDK, EDN, EDN2, EDN2/A, EDN5, EDN5/A, EDS, EDS1, EDS1/A, EDS2, EDS2/A, EDS3, EDS4, EDS6, EDS6/A, EDT, EDT/A, EDT1, EDT1/A, EDT2, EDT3, EDT6, EDT6/A, ED6, ED6/A, ED7, ED8, ED8/A, ED9, ED9/A, EMT, EMT/A, EN, ENT, ENT/A, ENT2, EN6, EN6/A, ES, ES1, ES1/A, ES3, ES3/A, ES4, ES4/A, ET, ETS, ETX, HA, HAQ, HA2, HA2/A, HH, HX, HX2, HX26, HX26/A, LH, LH/A, LHB1, LHB3, LHB3/A, LHB5, LHC, LHE, LHE/A, LHQ4, LHQ4/A, LHW, LJ, LJ/A, LJG, LJG/A, LJS, LJS/A, LJS1, LP, LSX, LT, LT/A, LX, LX/A, LXE, LXE/A, LXE2, LXE2/A, LXE4, LXE4/A, LXE6, LXE8, LXE8/A, LXQ4, LXQ4/A, LXU, LXU/A, LXZ, LX2, LX2/A, LX26, LX26/A, PKT2, PKT2/A, PKT4, PKT4/A, PKX2, PKX4, PKX4/A, PX, PX/A, PXA2, PXE8, PXE8/A, QA, QAB2, QAB2/A, QAC2, QAC2/A, QAE, QAE2, QAE2/A, QAG, QAG/A, QAG/A, QAH2, QAH2/A, QAP, QAPE, QAP2, QAP2/A, QAA, QA2, QA2/A, QA26, QA26/A, QDW9, QDW9/A, QE, QE/A, QH, QH/A, QHB3, QHB3/A, QHB5, QHC, QHE, QHE/A, QHP1, QHP1/A, QHQ4, QHQ4/A, QH2, QKA4, QKA4/A, QL2, QMEO, QMEO/A, QME8, QME8/A, QMH, QMH/A, QMT2, QMT2/A, QMX2, QNE, QNE2, QNE2/A, QNE6, QNE9, QNE9/A, QNR2, QNR2/A, QNR6, QNR6/A, QN18, QP, QP/A, QPE2, QT, QT/A, QTC2, QTC2/A, QWH2, QWH2/A, QX, QX/A, QXB, QXB/A, QXB7, QXB7/A, QXC, QXC/A, QXC4, QXC4/A, QXC6, QXC6/A, QXC9, QXC9/A, QXE, QXE/A, QXEB, QXE2, QXE4, QXE4/A, QXE6, QXE6/A, QXE8, QXE8/A, QXQ4, QXQ4/A, QXU, QXU/A, QX2, SE, SE/A, SH, SH/A, SHB1, SHB3, SHB3/A, SHE, SHEZ, SHQ4, SHQ4/A, SHT, SJ, SJ/A, SJG, SJG/A, SKE, SKE/A, SKZ, SKZ/A, SMEO, SMEO/A, SME2, SMX2, SMX2/A, STJ, STJ/A, STP, STP/A, STQ, STQ/A, STR, STR/A, SWX, SWX/A, SX, SX/A, SXB, SXB/A, SXB7, SXB7/A, SXE, SXE/A, SXEB, SXEB/A, SXE2, SXE4, SXE4/A, SXE8, SXE8/A, SXP, SXQ4, SXQ4/A, SXU, SXU/A, VA, VAA, VAAE, VAD2, VAD2/A, VAH1, VAH2, VAW1, VA2, VA2/A, VVC2, VVC2/A, VDE, VDE2, VDE2/A, VD16, VE, VEB6, VH, VHE, VH12, VH12/A, VH22, VH22/A, VMG, VMT, VMT/A, VMX, VNG, VNG1, VNG2, VSH7, VTE2, VWA, VWA2, VWC, VWC2, VWC2/A, VWE, VWE2, VWE2/A, VWS2, VWS2/A, VW12, VW12/A, VX, VX/A, VXA, VXB, VXB/A, VXB2, VXB7, VXB7/A, VXE, VXE/A, VXE6, VXE6/A, VXE2, VXE2/A, VXE4, VXE6, VXE7, VXE7/A, VXE8, VXE8/A, VXG, VXX, VXQ4, VXQ4/A, VXU, VXU/A, VXU1, VXU1/A, VX16, VX16/A, VX8, VX8/A, YJ
14	95701-06008-00	BOLT, FLANGE, 6X8 .....	-	(1)	1	-----	BJ, EDN, EDS, EDS3, EDT2, ED7, EN, ES, ET, ETS, ETX, HA, HAQ, HH, HX, HX2, LHB1, LHC, LHW, LP, LSX, LXE6, LXZ, QA, QAE, QAP, QAPE, QAA, QHC, QH2, QMX2, QNE, QNE6, QN18, QPE2, QXEB, QXE2, QX2, SHE, SHEZ, SHT, SME2, SXE2, SXP, VA, VAA, VAAE, VAH1, VAH2, VAW1, VDE, VD16, VE, VEB6, VH, VHE, VMX, VNG, VNG1, VNG2, VTE2, VWA, VWA2, VXA, VXB2, VXE4, VXE6, VXG, V1, YJ



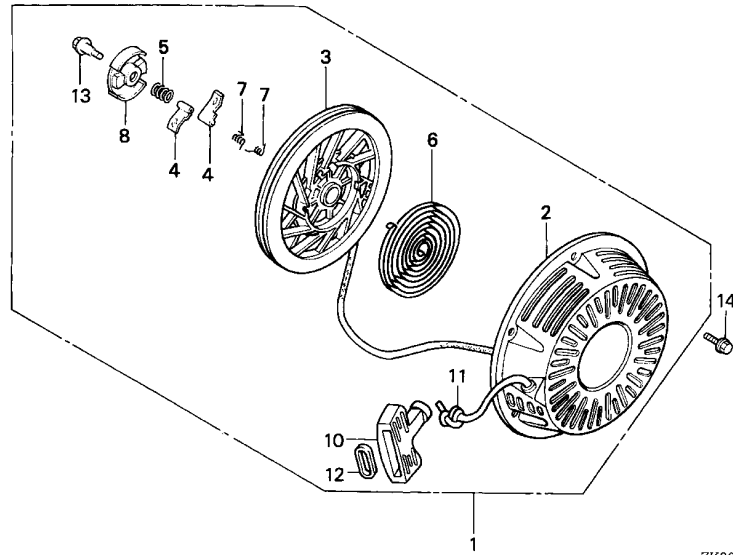

ZK30-E1100



Ref. No.	Part No.	Description	Reqd. QTY			Serial No.	Parts catalogue code
			GX	(1)	(2)		
14)	90008-ZE2-003	BOLT, FLANGE, 6X10	3	(3)	-	-	EDE2,EDE2/A,EDK,EDN2,EDN2/A,EDN5,EDN5/A,EDS1,EDS1/A,EDS2,EDS2/A,EDS4,EDS6,EDS6/A,EDT,EDT/A,EDT1,EDT1/A,EDT3,EDT6,EDT6/A,ED6,ED6/A,ED8,ED8/A,ED9,ED9/A,EMT,EMT/A,ENT,ENT/A,ENT2,EN6,EN6/A,ES1,ES1/A,ES3,ES3/A,ES4,ES4/A,HA2,HA2/A,HX26,HX26/A,LH,LH/A,LHB3,LHB3/A,LHB5,LHE,LHE/A,LHQ4,LHQ4/A,LJ,LJ/A,LJG,LJG/A,LJS,LJS/A,LJS1,LT,LT/A,LX,LX/A,LXE,LXE/A,LXE2,LXE2/A,LXE4,LXE4/A,LXE8,LXE8/A,LXQ4,LXQ4/A,LXU,LXU/A,LX2,LX2/A,LX26,LX26/A,L1,L1/A,PKT2,PKT2/A,PKT4,PKT4/A,PKX2,PKX4,PKX4/A,PX,PX/A,PXA2,PXE8,PXE8/A,P1,P1/A,QAB2,QAB2/A,QAC2,QAC2/A,QAE2,QAE2/A,QAE6,QAE6/A,QAG,QAG/A,QA2,QA2/A,QA26,QA26/A,QDW9,QDW9/A,QE,QE/A,QH,QH/A,QHB3,QHB3/A,QHB5,QHE,QHE/A,QHP1,QHP1/A,QHQ4,QHQ4/A,QKA4,QKA4/A,QL2,QMEO,QMEO/A,QME8,QME8/A,QMH,QMH/A,QMT2,QMT2/A,QNE2,QNE2/A,QNE9,QNE9/A,QNR2,QNR2/A,QNR6,QNR6/A,QP,QP/A,QT,QT/A,QTC2,QTC2/A,QWH2,QWH2/A,QX,QX/A,QXB,QXB/A,QXB7,QXB7/A,QXC,QXC/A,QXC4,QXC4/A,QXC6,QXC6/A,QXC9,QXC9/A,QXE,QXE/A,QXE4,QXE4/A,QXE6,QXE6/A,QXE8,QXE8/A,QXQ4,QXQ4/A,QXU,QXU/A,Q1,Q1/A,SE,SE/A,SH,SH/A,SHB1,SHB3,SHB3/A,SHQ4,SHQ4/A,SJ,SJ/A,SJG,SJG/A,SKE,SKE/A,SKZ,SKZ/A,SMEO,SMEO/A,SMX2,SMX2/A,STJ,STJ/A,STP,STP/A,STQ,STQ/A,STR,STR/A,SWX,SWX/A,SX,SX/A,SXB,SXB/A,SXB7,SXB7/A,SXE,SXE/A,SXEB,SXEB/A,SXE4,SXE4/A,SXE8,SXE8/A,SXQ4,SXQ4/A,SXU,SXU/A,S1,S1/A,VAD2,VAD2/A,VA2,VA2/A,VC2,VC2/A,VDE2,VDE2/A,VH12,VH12/A,VH22,VH22/A,VMQ,VMT,VMT/A,VSH7,VMC,VMC2,VMC2/A,VME,VME2,VME2/A,VMS2,VMS2/A,VW12,VW12/A,VX,VX/A,VXB,VXB/A,VXB7,VXB7/A,VXE,VXE/A,VXE4,VXE4/A,VXE6,VXE6/A,VXE7,VXE7/A,VXE8,VXE8/A,VXK,VXK4,VXK4/A,VXU,VXU/A,VXU1,VXU1/A,VX16,VX16/A,VX8,VX8/A
			-	-	3		

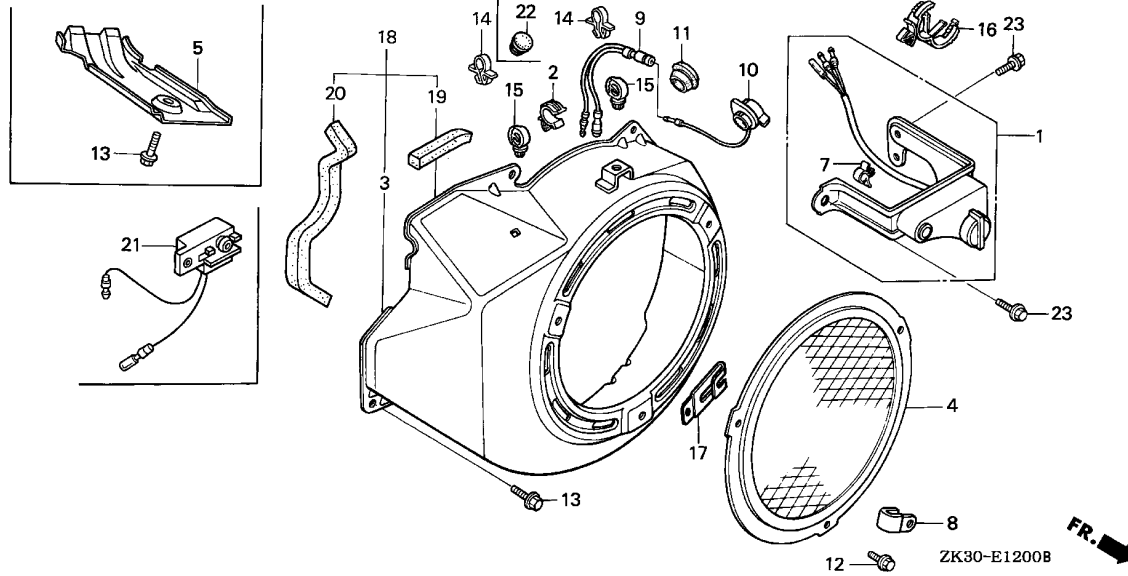

Ref. No.	L.O.N.	(Relative ref. Number) Description	F.R.T.
1	6151C6	SWITCH, OIL ALERT UNIT .....	0.1
4	4141C9	PROTECTOR, FAN COVER .....	0.1
9	6111A3	CORD, ENGINE STOP SWITCH .....	0.1
10	6151D9	SWITCH, ENGINE STOP .....	0.2
18		(3)	
	1141G8	COVER, ENGINE COOLING FAN ....	0.2

Ref. No.	Part No.	Description	Reqd. QTY			Serial No.	Parts catalogue code
			GX	(1)	(2)		
1	15520-ZE2-003	ALERT UNIT, OIL .....	1	(1)	-	2143683 ES1,HA,HX,LX,LXZ,L1,PX,P1,QA,QAP,QX,QXB,QXC,Q1,SWX,SX,SXB,SXP,S1 VA,VAA,VAH1,VNG,VNG1,VX,VXA,VXB,V1	



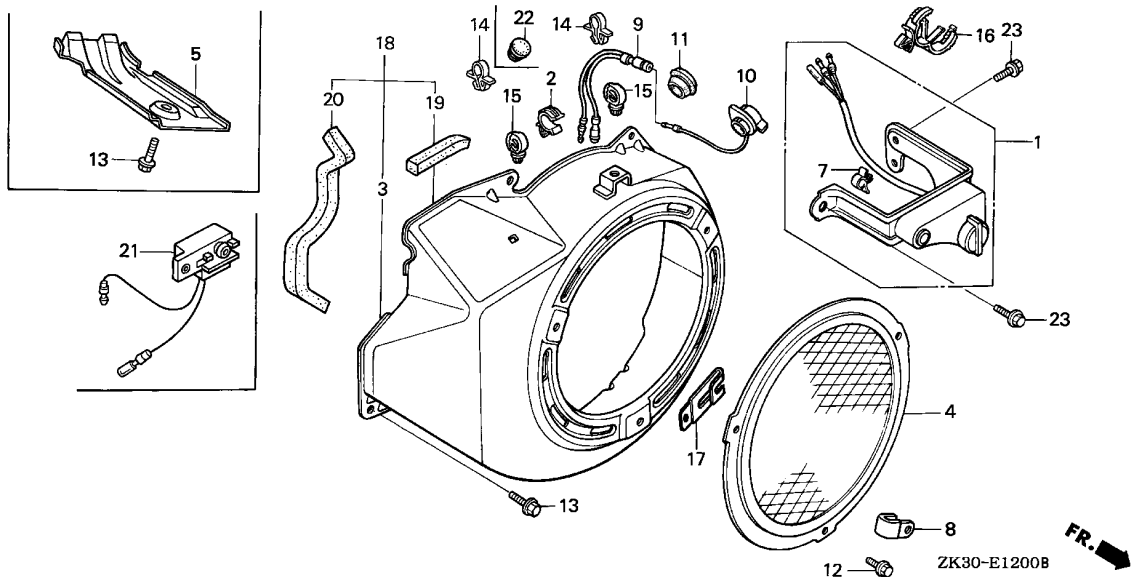

Ref. No.	Part No.	Description	Reqd. QTY			Serial No.	Parts catalogue code						
			GX	(1)	(2)			(3)					
2	16731-ZE2-003	CLIP, TUBE .....	1	-	-	-----	BJ,EDK,EDN5,EDN5/A,ED7,ED8,ED8/A,ED9,ED9/A,EN,ES,ES1,ES1/A,ES2,ETS,ETX,HA,HAQ,HA2,HA2/A,HH,HX,HX2,HX26,HX26/A,LH,LH/A,LHB1,LHB3,LHB3/A,LHB5,LHC,LHE,LHE/A,LHQ4,LHQ4/A,LHW,LJ,LJ/A,LJG,LJG/A,LJS,LJS/A,LJS1,LKE,LKE/A,LP,LSX,LT,LT/A,LWD,LWD1,LWD1/A,LX,LX/A,LXE,LXE/A,LXE2,LXE2/A,LXE4,LXE4/A,LXE6,LXE8,LXE8/A,LXQ4,LXQ4/A,LXU,LXU/A,LXZ,LX2,LX2/A,LX26,LX26/A,PKT2,PKT2/A,PKT4,PKT4/A,PKX2,PKX4,PKX4/A,PX,PX/A,PXA2,PXE8,PXE8/A,QA,QAB2,QAB2/A,QAC2,QAC2/A,QAE,QAE2,QAE2/A,QAE6,QAE6/A,QAG,QAG/A,QA2,QA2/A,QAP,QAPE,QAPE2,QAP2/QAP2/A,QAQ,QA2,QA2/A,QA26,QA26/A,QDW9,QDW9/A,QE,QE/A,QH,QH/A,QHB3,QHB3/A,QHB5,QHC,QHE,QHE/A,QHP1,QHP1/A,QHQ4,QHQ4/A,QH2,QKA4,QKA4/A,QL2,QMEO,QMEO/A,QME8,QME8/A,QMH,QMH/A,QMT2,QMT2/A,QMX2,QNE,QNE2,QNE2/A,QNE6,QNE9,QNE9/A,QNR2,QNR2/A,QNR6,QNR6/A,QN18,QP,QP/A,QPE2,QT,QT/A,QTC2,QTC2/A,QWH2,QWH2/A,QX,QX/A,QXB,QXB/A,QXB7,QXB7/A,QXC,QXC/A,QXC4,QXC4/A,QXC6,QXC6/A,QXC9,QXC9/A,QXE,QXE/A,QXE6,QXE6/A,QXE8,QXE8/A,QXQ4,QXQ4/A,QXU,QXU/A,QX2,SDE,SE,SE/A,SH,SH/A,SHB1,SHB3,SHB3/A,SHE,SHEZ,SHQ4,SHQ4/A,SHT,SJ,SJ/A,SJG,SJG/A,SKE,SKE/A,SKZ,SKZ/A,SME0,SME0/A,SME2,SMX2,SMX2/A,STJ,STJ/A,STP,STP/A,STQ,STQ/A,STR,STR/A,SWX,SWX/A,SX,SX/A,SXB,SXB/A,SXB7,SXB7/A,SXE,SXE/A,SXEB,SXEB/A,SXE2,SXE4,SXE4/A,SXE8,SXE8/A,SXP,SXQ4,SXQ4/A,SXU,SXU/A,VA,VAE,VAE2,VAE2/A,VAH1,VAH1,VAH2,VAH2/A,VA2,VA2/A,VC2,VC2/A,VDE,VDE2,VDE2/A,VD16,VE,VEB6,VH,VHE,VH12,VH12/A,VH22,VH22/A,VMX,VNG,VNG1,VNG2,VSH7,VWC,VWC2/A,VME,VME2,VME2/A,VWS2/A,VW12,VW12/A,VX,VX/A,VXA,VXB,VXB/A,VXB2,VXB7,VXB7/A,VXE,VXE/A,VXEB,VXEB/A,VXE2,VXE2/A,VXE4,VXE6,VXE7,VXE7/A,VXE8,VXE8/A,VXG,VXK,VXQ4,VXQ4/A,VXU,VXU/A,VXU1,VXU1/A,VX16,VX16/A,VX8,VX8/A,YJ	1	-	-	2481978	-----	VWA2,VWC2,VWS2
			-	1	-								

Ref. No.	Part No.	Description	Reqd. QTY			Serial No.	Parts catalogue code	
			GX 340K1 (1)	(2)	(3)			
3	19610-ZE3-000ZA	COVER COMP., FAN *R8*.....BRIGHT RED	1	(1)	-	2177363	BJ, ED7, ED8, ED9, EN, ES, ES1, ET, ETS, ETX, HA, HH, HX, LH, LHC, LHE, LJ, LKE, LP LX, LXE, LXZ, L1, PX, P1, QA, QAE, QAP, QAPE, QE, QH, QHC, QHE, QNE, QP, QT, QX QXC, QXE, Q1, SE, SH, SHE, SHEZ, SJ, STJ, STP, STQ, SWX, SX, SXE, SXP, S1, VA VAH1, VAH2, VE, VH, VHE, VX, VXA, VXE, V1, YJ	
	19610-ZE3-010ZA	*R8*.....BRIGHT RED	1	(1)	-	-----	HAQ, HA2, HX2, HX26, LHB1, LHB3, LHQ4, LHW, LJG, LJS, LSX, LT, LXE2, LXE4, LXE6 LXE8, LXQ4, LXU, LX2, LX26, L1/A, PKT2, PKT4, PKX4, PXE8, P1/A, QAB2, QAC2 QAE2, QAE6, QAG, QAH2, QAP2, QAQ, QA2, QA26, QHB3, QHP1, QHQ4, QH2, QKA4, QMEO QME8, QMH, QMT2, QMX2, QNE2, QNE6, QNE9, QNR2, QNR6, QN18, QTC2, QXC4, QXC6 QXC9, QXE2, QXE4, QXE6, QXE8, QXQ4, QXU, Q1/A, SDE, SHB1, SHB3, SHQ4, SHT, SJG SKE, SKZ, SME0, SME2, SMX2, STR, SXE2, SXE4, SXE8, SXQ4, SXU, S1/A, VAD2, VA2 VC2, VDE, VDE2, VH12, VH22, VMX, VWA, VW12, VXE2, VXE4, VXE6, VXE8, VXQ4, VXU VXU1, VX16, VX8	
			1	(1)	-	2177364	-----	BJ, ED7, ED8, ED9, EN, ES, ES1, ET, ETS, ETX, HA, HH, HX, LH, LHC, LHE, LJ, LKE, LP LX, LXE, LXZ, L1, PX, P1, QA, QAE, QAP, QAPE, QE, QH, QHC, QHE, QNE, QP, QT, QX QXC, QXE, Q1, SE, SH, SHE, SHEZ, SJ, STJ, STP, STQ, SWX, SX, SXE, SXP, S1, VA VAH1, VAH2, VE, VH, VHE, VX, VXA, VXE, V1, YJ
			1	-	-	3658029	PKX2	
			1	-	-	3662093	ED8/A, ED9/A, ES1/A, HA2/A, HX26/A, LH/A, LHB3/A, LHB5, LHE/A, LHQ4/A, LJ/A LJG/A, LJS/A, LKE/A, LT/A, LWD, LX/A, LXE/A, LXE2/A, LXE4/A, LXE8/A, LXQ4/A LXU/A, LX2/A, LX26/A, PKT2/A, PKT4/A, PKX4/A, PX/A, PXE8/A, QAB2/A, QAC2/A QAE2/A, QAE6/A, QAG/A, QAH2/A, QAP2/A, QA2/A, QA26/A, QE/A, QH/A, QHB3/A QHB5, QHE/A, QHP1/A, QHQ4/A, QKA4/A, QMEO/A, QME8/A, QMH/A, QMT2/A, QNE2/A QNE9/A, QNR2/A, QNR6/A, QP/A, QT/A, QTC2/A, QX/A, QXC/A, QXC4/A, QXC6/A QXC9/A, QXE/A, QXE4/A, QXE6/A, QXE8/A, QXQ4/A, QXU/A, SE/A, SH/A, SHB3/A SHQ4/A, SJ/A, SJG/A, SKE/A, SKZ/A, SME0/A, SMX2/A, STJ/A, STP/A, STQ/A STR/A, SWX/A, SX/A, SXE/A, SXE4/A, SXE8/A, SXQ4/A, SXU/A, VAD2/A, VA2/A VC2/A, VDE2/A, VH12/A, VH22/A, VW12/A, VX/A, VXE/A, VXE2/A, VXE8/A, VXQ4/A VXU/A, VXU1/A, VX16/A, VX8/A	
	19610-ZE3-010ZB	*NH1*.....BLACK	1	-	1	-----	EDK, EDN5, EDN5/A, ED8, ED8/A, ED9, ED9/A, QAE2, QAE2/A, QAP2, QAP2/A, QA2 QA2/A, QDW9, QDW9/A, QKA4, QKA4/A, QL2, QMEO, QMEO/A, QMT2, QMT2/A, QMX2 QNR2, QNR2/A, QPE2, QWH2, QWH2/A, QXQ4, QXQ4/A, QXU, QXU/A, QX2, SME0 SME0/A, SME2, SMX2, SMX2/A, VWC2, VWC2/A	
	19610-ZE3-010ZC	*T34*.....SIMPSON BLUE	1	-	-	-----	QA2, QA2/A	
	19610-ZE3-010ZD	*T39*.....GEKO BLUE	1	-	-	-----	VXE4	
	19610-ZE3-010ZE	*T41*.....BARTELL BLUE METALLIC	1	-	-	-----	QA2, QA2/A, QA26, QA26/A	
	19610-ZE3-010ZG	*NH105*...MAT BLACK (#15-#20)	1	-	-	-----	VAW1, VDE2, VDE2/A, VWA2, VWC, VWC2, VWC2/A, VWE, VWE2, VWE2/A, VWS2, VWS2/A VW12, VW12/A, VXE2, VXE2/A	
	19610-ZE3-010ZH	*NH246*.....LOOSEY GRAY	1	-	-	-----	HAQ, QAQ, QNE9, QNE9/A	
	19610-ZE3-010ZJ	*Y131*.....LIGHTNING YELLOW	1	-	-	-----	ES1, ES1/A, ES2	
	19610-ZE3-010ZK	*T77*.....SEC WINE RED	1	-	-	-----	ES1, ES1/A, ES2	
	19610-ZE3-700ZA	*R8*.....BRIGHT RED	1	-	-	-----	EDS, EDS1, EDS3, EDS6, EDT1, EDT6, ED6, EMT, ENT, ES3, ES4, VMT, VTE2	
	19610-ZE3-700ZB	*NH1*.....BLACK	1	-	-	3663164	EDS1/A, EDS6/A, EDT1/A, EDT6/A, ED6/A, EMT/A, ENT/A, ES3/A, ES4/A, VMT/A EDE2, EDE2/A, EDN, EDN2, EDN2/A, EDS1, EDS1/A, EDS2, EDS2/A, EDS4, EDS6 EDS6/A, EDT1, EDT1/A, EDT2, EDT3, EDT6, EDT6/A, ED6, ED6/A, ENT, ENT/A, ENT2 EN6, EN6/A, ES3, ES3/A, ES4, ES4/A, ZK1, ZK1/A	
	19610-ZE3-700ZF	*T68*.....TSURUMI BLUE	1	-	-	-----	EDT, EDT/A, ED6, ED6/A	
	19610-ZE3-700ZG	*Y131*.....LIGHTNING YELLOW	1	-	-	-----	EDE2, EDE2/A, ED6, ED6/A, ENT, ENT/A, ES3, ES3/A, ES4, ES4/A	
	19610-ZE3-700ZH	*T77*.....SEC WINE RED	1	-	-	-----	ES3, ES3/A, ES4, ES4/A	
	19610-ZE3-700ZJ	*T80*.....BAKELITE ORANGE	1	-	-	-----	ED6, ED6/A, ES3, ES3/A, ES4, ES4/A	
	19610-ZE3-W00ZA	COVER COMP., FAN (100DB) *R8*.....BRIGHT RED	1	-	-	2169293	QXB, QXEB, SXB, SXEB, VAA, VAAE, VNG, VNG1, VNG2, VXB, VXEB	
	19610-ZE3-W00ZB	COVER COMP., FAN *T39*.....GEKO BLUE	1	-	-	2169293	VXEB	



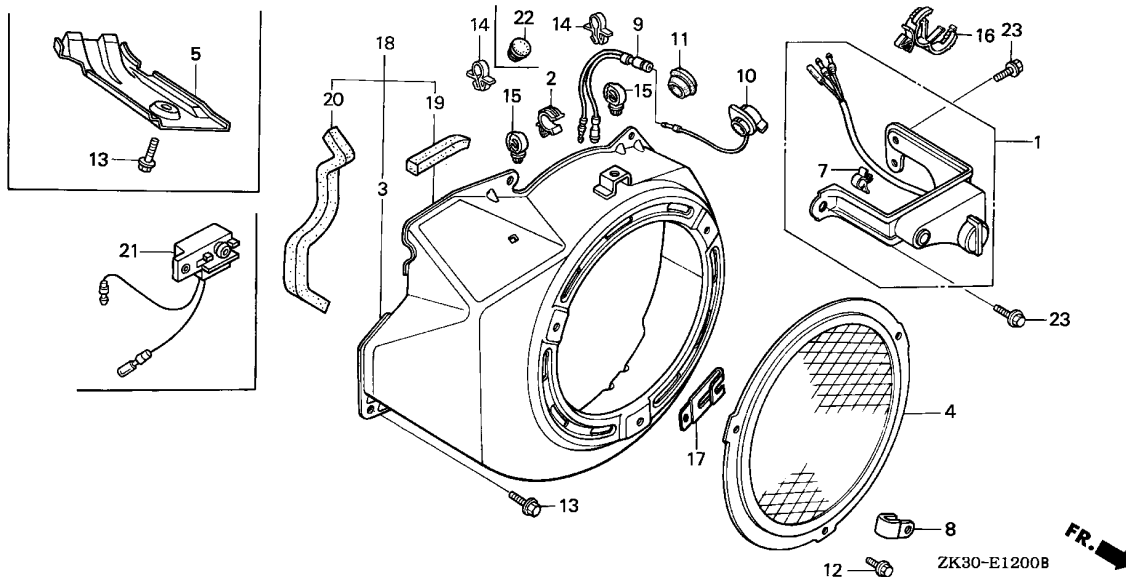

Ref. No.	Part No.	Description	Reqd. QTY			Serial No.	Parts catalogue code
			GX	340K1			
			(1)	(2)	(3)		
(3)	19610-ZE3-W01ZA	COVER COMP., FAN	1	-	-	-----	QXB7, SXB7, VD16, VEB6, VXB2, VXB7, VXE7, VXG
		*R8*.....BRIGHT RED	1	-	-	2169294	QXB, QXEB, SXB, SXEB, VAA, VAAE, VNG, VNG1, VNG2, VXB, VXEB
			1	-	-	3664509	QXB7/A, SXB7/A, VXB7/A, VXE7/A
			1	-	-	3676807	QXB/A, SXB/A, SXEB/A, VXB/A, VXEB/A
	19610-ZE3-W01ZE	*NH105*...MAT BLACK (#15-#20)	1	-	-	-----	VXB7, VXE7
			1	-	-	3961312	VXB7/A, VXE7/A
	19610-ZE3-010ZL	*R280*.....POWER RED	1	-	-	-----	EDK, ES2, LJS1, PXA2, VXK
			1	-	-	3658030	PKX2
			1	-	-	3662094	ED8/A, ED9/A, ES1/A, HA2/A, HX26/A, LH/A, LHB3/A, LHB5, LHE/A, LHQ4/A, LJ/A, LJG/A, LJS/A, LKE/A, LT/A, LWD, LX/A, LXE/A, LXE2/A, LXE4/A, LXE8/A, LXQ4/A, LXU/A, LX2/A, LX26/A, PKT2/A, PKT4/A, PKX4/A, PX/A, PXE8/A, QAB2/A, QAC2/A, QAE2/A, QAE6/A, QAG/A, QAH2/A, QAP2/A, QA2/A, QA26/A, QDW9/A, QE/A, QH/A, QHB3/A, QHB5, QHE/A, QHP1/A, QHQ4/A, QKA4/A, QMEO/A, QME8/A, QMH/A, QMT2/A, QNE2/A, QNE9/A, QNR2/A, QNR6/A, QP/A, QT/A, QTC2/A, QWH2/A, QX/A, QXC/A, QXC4/A, QXC6/A, QXC9/A, QXE/A, QXE4/A, QXE6/A, QXE8/A, QXQ4/A, QXU/A, SE/A, SH/A, SHB3/A, SHQ4/A, SJ/A, SJG/A, SKE/A, SKZ/A, SMEO/A, SMX2/A, STJ/A, STP/A, STQ/A, STR/A, SWX/A, SX/A, SXE/A, SXE4/A, SXEB/A, SXQ4/A, SXU/A, VAD2/A, VA2/A, VC2/A, VDE2/A, VH12/A, VH22/A, VWC2/A, VWE2/A, VWS2/A, VW12/A, VX/A, VXE/A, VXE2/A, VXE8/A, VXQ4/A, VXU/A, VXU1/A, VX16/A, VX8/A
	19610-ZE3-700ZK	*R280*.....POWER RED	1	-	-	-----	EDS4, EDT3, VMQ
			1	-	-	3663165	EDE2/A, EDS1/A, EDS6/A, EDT1/A, EDT6/A, ED6/A, EMT/A, ENT/A, ES3/A, ES4/A, VMT/A, ZK1/A
	19610-ZE3-700ZL	*NH105*...MAT BLACK (#15-#20)	1	-	-	-----	VS2, VS3, VS4, VS5, VS6, VS7
	19610-ZE3-W01ZB	*T39*.....GEKO BLUE	1	-	-	2169294	VXEB
			1	-	-	3961312	VXEB/A

Ref. No.	Part No.	Description	Reqd. QTY			Serial No.	Parts catalogue code
			(1)	(2)	(3)		
(3)	19610-ZE3-W01ZF	COVER COMP., FAN *R280*.....POWER RED	1	-	-	3961312	VSH7
			1	-	-	3664510	3961312 QXB7/A, SXB7/A, VXB7/A, VXE7/A
			1	-	-	3676808	3961312 QXB/A, SXB/A, SXEB/A, VXB/A, VXE7/A
	19610-ZE3-W02ZE	*NH105*...MAT BLACK (#15-#20)	1	-	-	3961313	VXB7/A, VXE7/A
	19610-ZE3-W02ZB	*T39*.....GEKO BLUE	1	-	-	3961313	VXEB/A
	19610-ZE3-W02ZF	*R280*.....POWER RED	1	-	-	3961313	QXB/A, QXB7/A, SXB/A, SXB7/A, SXEB/A, VSH7, VXB/A, VXB7/A, VXE7/A, VXE8/A
4	19620-ZE3-L60ZA	PROTECTOR COMP., FAN COVER *NH1*.....BLACK	1	-	-		ZK1, ZK1/A
	19620-ZE3-810		1	(1)	-		LKE, LWD1, L1, L1/A, P1, P1/A, Q1, Q1/A, SDE, S1, S1/A
			1	-	-	3717867	LKE/A, LWD, LWD1/A
	19620-ZE3-811		1	-	-	3717868	LKE/A, LWD, LWD1/A
5	19631-ZE3-W00	SHROUD .....	1	-	-		BJ, EDE2, EDE2/A, EDK, EDN, EDN2, EDN2/A, EDN5, EDN5/A, EDS, EDS1, EDS1/A, EDS2, EDS2/A, EDS3, EDS4, EDS6, EDS6/A, EDT, EDT/A, EDT1, EDT1/A, EDT2, EDT3, EDT6, EDT6/A, ED6, ED6/A, ED7, ED8, ED8/A, ED9, ED9/A, EMT, EMT/A, EN, ENT, ENT/A, ENT2, EN6, EN6/A, ES, ES1, ES1/A, ES2, ES3, ES3/A, ES4, ES4/A, ET, ETS, ETX, HA, HAQ, HA2, HA2/A, HH, HX, HX2, HX26, HX26/A, LH, LH/A, LHB1, LHB3, LHB3/A, LHB5, LHC, LHE, LHE/A, LHQ4, LHQ4/A, LHW, LJ, LJ/A, LJG, LJG/A, LJS, LJS/A, LJS1, LKE, LKE/A, LP, LSX, LT, LT/A, LWD, LWD1, LWD1/A, LX, LX/A, LXE, LXE/A, LXE2, LXE2/A, LXE4, LXE4/A, LXE6, LXE8, LXE8/A, LXQ4, LXQ4/A, LXU, LXU/A, LXZ, LX2, LX2/A, LX26, LX26/A, PKT2, PKT2/A, PKT4, PKT4/A, PKX2, PKX4, PKX4/A, PX, PX/A, PXA2, PXE8, PXE8/A, QA, QAB2, QAB2/A, QAC2, QAC2/A, QAE, QAE2, QAE2/A, QAE6, QAE6/A, QAG, QAG/A, QAH2, QAH2/A, QAP, QAPE, QAP2, QAP2/A, QAQ, QA2, QA2/A, QA26, QA26/A, QDW9, QDW9/A, QE, QE/A, QH, QH/A, QHB3, QHB3/A, QHB5, QHC, QHE, QHE/A, QHP1, QHP1/A, QHQ4, QHQ4/A, QH2, QKA4, QKA4/A, QL2, QMED, QMED/A, QME8, QME8/A, QMH, QMH/A, QMT2, QMT2/A, QMX2, QNE, QNE2, QNE2/A, QNE6, QNE9, QNE9/A, QNR2, QNR2/A, QNR6, QNR6/A, QN18, QP, QP/A, QPE2, QT, QT/A, QTC2, QTC2/A, QWH2, QWH2/A, QX, QX/A, QXB, QXB/A, QXB7, QXB7/A, QXC, QXC/A, QXC4, QXC4/A, QXC6, QXC6/A, QXC9, QXC9/A, QXE, QXE/A, QXEB, QXE2, QXE4, QXE4/A, QXE6, QXE6/A, QXE8, QXE8/A, QXQ4, QXQ4/A, QXU, QXU/A, QX2, SDE, SE, SE/A, SH, SH/A, SHB1, SHB3, SHB3/A, SHE, SHEZ, SHQ4, SHQ4/A, SHT, SJ, SJ/A, SJG, SJG/A, SKE, SKE/A, SKZ, SKZ/A, SMEO, SMEO/A, SME2, SMX2, SMX2/A, STJ, STJ/A, STP, STP/A, STQ, STQ/A, STR, STR/A, SWX, SWX/A, SX, SX/A, SXB, SXB/A, SXB7, SXB7/A, SXE, SXE/A, SXEB, SXEB/A, SXE2, SXE4, SXE4/A, SXE8, SXE8/A, SXP, SXQ4, SXQ4/A, SXU, SXU/A, VA, VAA, VAAE, VAD2, VAD2/A, VAH1, VAH2, VAW1, VA2, VA2/A, VC2, VC2/A, VDE, VDE2, VDE2/A, VD16, VE, VEB6, VH, VHE, VH12, VH12/A, VH22, VH22/A, VMQ, VMT, VMT/A, VMX, VNG, VNG1, VNG2, VSH7, VS2, VS3, VS4, VS5, VS6, VS7, VTE2, VWA, VWA2, VWC, VWC2, VWC2/A, VWE, VWE2, VWE2/A, VWS2, VWS2/A, VW12, VW12/A, VX, VX/A, VXA, VXB, VXB/A, VXB2, VXB7, VXB7/A, VXE, VXE/A, VXE8, VXE8/A, VXE2, VXE2/A, VXE4, VXE4/A, VXE6, VXE6/A, VXE7, VXE7/A, VXE8, VXE8/A, VXG, VXX, VXQ4, VXQ4/A, VXU, VXU/A, VXU1, VXU1/A, VX16, VX16/A, VX8, VX8/A, YJ, ZK1, ZK1/A
			-	1	1		
7	30701-883-000	CLIP, HIGH TENSION CORD (8MM)	1	(1)	-	2143683	ES1, HA, HX, LX, LXZ, L1, PX, P1, QA, QAP, QX, QXB, QXC, Q1, SWX, SX, SXB, SXP, S1, VA, VAA, VAH1, VNG, VNG1, VX, VXA, VXB, V1
8	32111-426-000	CLAMPER, CORD .....	1	-	-		ZK1, ZK1/A



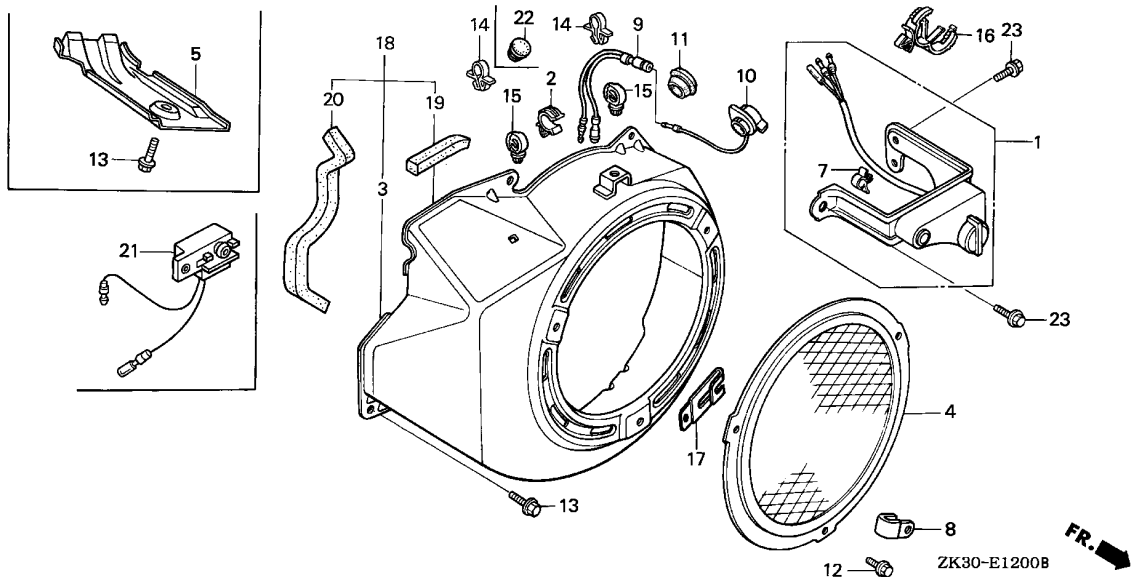

Ref. No.	Part No.	Description	Reqd. QTY			Serial No.	Parts catalogue code
			GX	340K1			
			(1)	(2)	(3)		
9	32197-ZH8-003	SUB HARNESS .....	1	1	-	-----	EDS,EDS1,EDS1/A,EDS2,EDS2/A,EDS3,EDS4,EDS6,EDS6/A,EDT,EDT/A,EDT1 EDT1/A,EDT2,EDT3,EDT6,EDT6/A,ED6,ED6/A,ED9,ED9/A,EMT,EMT/A,ENT ENT/A,ENT2,EN6,EN6/A,ES1/A,ETS,HX26,HX26/A,LSX,LXQ4,LXQ4/A,LXU LXU/A,LX26,LX26/A,L1,L1/A,PX/A,QAC2,QAC2/A,QA2,QA2/A,QA26 QA26/A,QX/A,QXB/A,QXC4,QXC4/A,QXC6,QXC6/A,QXQ4,QXQ4/A,QXU,QXU/A SHT,SKE,SKE/A,SKZ,SKZ/A,SWX/A,SX/A,SXB/A,SXQ4,SXQ4/A,SXU,SXU/A VD16,VX/A,VXB/A,VXB2,VXG,VXQ4,VXQ4/A,VXU,VXU/A,VX16,VX16/A,VX8 VX8/A
			1	1	-	2639737	HAQ,HA2,HX2,LX2,PKT2,P1,QAP2,QAQ,QA2,QDW9,QMT2,QTC2,QXC9,QX2,Q1 SMX2,S1,VAD2,VAW1,VA2,VDE,VDE2,VH12,VWC2,VW12,V1
			1	-	-	2143684	ES1,HX,LXZ,PX,QX,QXB,SWX,SX,SXB,VAA,VNG,VNG1,VX,VXB
			1	-	-	2160981	ETX
			1	-	-	2143684	2639737 HA,LX,QA,QAP,QXC,SXP,VA,VAH1,VXA
			-	-	1	1000020	
10	36100-ZE1-015	SWITCH ASSY., ENGINE STOP ...	1	(1)	-	-----	BJ,ED8,ED8/A,EN,ES,HH,LH,LH/A,LHB1,LHB3,LHB3/A,LHB5,LHC,LHW,LJ LJ/A,LJG,LJG/A,LJS,LJS/A,LJS1,LP,LT,LT/A,L1,L1/A,QH,QH/A,QHB3 QHB3/A,QHB5,QHC,QHP1,QHP1/A,QH2,QMH,QMH/A,QP,QP/A,QT,QT/A,SH,SH/A SHB1,SHB3,SHB3/A,SJ,SJ/A,SJG,SJG/A,SKZ,SKZ/A,STP,STP/A,STQ,STQ/A STR,STR/A,VE,VH,YJ
			1	(1)	-	2639737	ED9,HAQ,HA2,HX2,HX26,LSX,LX2,LX26,PKT2,P1,QAP2,QAQ,QA2,QA26,QDW9 QMT2,QTC2,QXC6,QXC9,QX2,Q1,SHT,SMX2,S1,VAD2,VAW1,VA2,VDE,VDE2 VH12,VWC2,VW12,VXB2,VXU,VX16,V1
			1	-	-	2338539	QE,SE,VXG
			1	-	-	2143684	2338539 QXB,SXB,VNG1,VXB
			1	-	-	2143684	2639737 ES1,HA,HX,LX,LXZ,PX,QA,QAP,QX,QXC,SWX,SX,SXP,VA,VAA,VAH1,VNG,VX VXA
			1	-	-	2338540	2639737 VD16
			-	-	1	1000004	VXP



Ref. No.	Part No.	Description	Reqd. QTY			Serial No.	Parts catalogue code	
			(1)	(2)	(3)			
10)	36100-ZH7-003	SWITCH ASSY., ENGINE STOP ...	1	1	-	-----	EDK,EDN5,EDN5/A,ED9/A,ES1/A,ES2,HA2/A,HX26/A,LX/A,LXU,LXU/A,LX2/A LX26/A,L1/A,PKT2/A,PKX2,PX/A,PKA2,P1/A,QAB2,QAB2/A,QAG,QAH2 QAH2/A,QA26/A,QMT2/A,QMX2,QTC2/A,QWH2,QWH2/A,QX/A,QXC/A,QXC6/A QXU,QXU/A,Q1/A,SMX2/A,SWX/A,SX/A,SXU,SXU/A,S1/A,VAD2/A,VA2/A,VC2 VC2/A,VDE2/A,VH12/A,VMX,VW12/A,VX/A,VXK,VXU/A,VX16/A,VX8,VX8/A ED9,ES1,HA,HAQ,HA2,HX,HX2,HX26,LSX,LX,LXZ,LX2,LX26,L1,PKT2,PX,P1 QA,QAP,QAP2,QAQ,QA2,QA26,QDW9,QMT2,QTC2,QX,QXC,QXC6,QXC9,QX2,Q1 SHT,SMX2,SWX,SX,SXP,S1,VA,VAA,VAD2,VAH1,VAW1,VA2,VDE,VDE2,VD16 VH12,VNG,VWC2,VW12,VX,VXA,VXB2,VXU,VX16,V1 QAG/A,QAP2/A,QA2/A,QDW9/A,QXC9/A,VWC2/A	
			1	1	-	2639738	-----	VXP
	36100-ZF6-P81	.....	-	-	1	1000005	-----	QAG/A,QAP2/A,QA2/A,QDW9/A,QXC9/A,VWC2/A
	36100-ZH8-W41	.....	1	-	-	3930788	-----	LHQ4,LHQ4/A,QE/A,QHQ4,QHQ4/A,SE/A,SHQ4,SHQ4/A
			1	-	-	2338540	-----	QE,SE
			1	-	-	2338539	-----	VD16
			1	-	-	2639737	-----	LXQ4,QXC4,QXQ4,SXQ4,VXQ4
			1	-	-	2338540	-----	2639737 QXB,SXB,VNG1,VXB,VXG
			-	-	1	1000004	-----	VXQP
	36100-ZH7-W41	.....	1	-	-	-----	-----	LXQ4/A,PKT4,PKT4/A,PKX4,PKX4/A,QKA4/A,QXB/A,QXB7,QXB7/A,QXC4/A QXQ4/A,SXB/A,SXB7,SXB7/A,SXQ4/A,VSH7,VXB/A,VXB7,VXB7/A,VXQ4/A
			1	-	-	2639738	-----	LXQ4,QXB,QXC4,QXQ4,SXB,SXQ4,VNG1,VXB,VXG,VXQ4
			1	-	-	3105643	-----	QKA4
			-	-	1	1000005	-----	VXQP
11	81329-567-020	GROMMET, DRAIN HOLE .....	1	-	-	-----	-----	EDE2,EDE2/A,EDN,EDN2,EDN2/A,EDS,EDS1,EDS1/A,EDS2,EDS2/A,EDS3,EDS4 EDS6,EDS6/A,EDT,EDT/A,EDT1,EDT1/A,EDT2,EDT3,EDT6,EDT6/A,ED6,ED6/A ED7,EMT,EMT/A,ENT,ENT/A,ENT2,EN6,EN6/A,ES3,ES3/A,ES4,ES4/A,ET,ETS ETX,LHE,LHE/A,LKE,LKE/A,LP,LWD,LWD1,LWD1/A,LXE,LXE/A,LXE2,LXE2/A LXE4,LXE4/A,LXE6,LXE8,LXE8/A,PXE8,PXE8/A,QAC2,QAC2/A,QAE,QAE2 QAE2/A,QAE6,QAE6/A,QAPE,QHE,QHE/A,QMEO,QMEO/A,QME8,QME8/A,QNE QNE2,QNE2/A,QNE6,QNE9,QNE9/A,QNR2,QNR2/A,QNR6,QNR6/A,QN18,QPE2 QXE,QXE/A,QXEB,QXE2,QXE4,QXE4/A,QXE6,QXE6/A,QXE8,QXE8/A,SDE,SHE SHEZ,SKE,SKE/A,SMEO,SMEO/A,SME2,STJ,STJ/A,STR,STR/A,SXE,SXE/A SXEB,SXEB/A,SXE2,SXE4,SXE4/A,SXE8,SXE8/A,VAAE,VAH2,VEB6,VHE,VH22 VH22/A,VMQ,VMT,VMT/A,VNG2,VS2,VS3,VS4,VS5,VS6,VS7,VTE2,VWA,VWA2 VWC,VWE,VWE2,VWE2/A,VWS2,VWS2/A,VXE,VXE/A,VXEB,VXEB/A,VXE2,VXE2/A VXE4,VXE6,VXE7,VXE7/A,VXE8,VXE8/A,VXU1,VXU1/A,ZK1,ZK1/A
			1	-	-	2143683	-----	ES1,HA,HX,LX,LXZ,PX,QA,QAP,QX,QXB,QXC,SWX,SX,SXB,SXP,VA,VAA,VAH1 VNG,VNG1,VX,VXA,VXB
12	95701-06008-00	BOLT, FLANGE, 6X8 .....	3	(1)	-	-----	-----	LKE,LKE/A,LWD,LWD1,LWD1/A,L1,L1/A,Q1,Q1/A,SDE,S1,S1/A,ZK1,ZK1/A



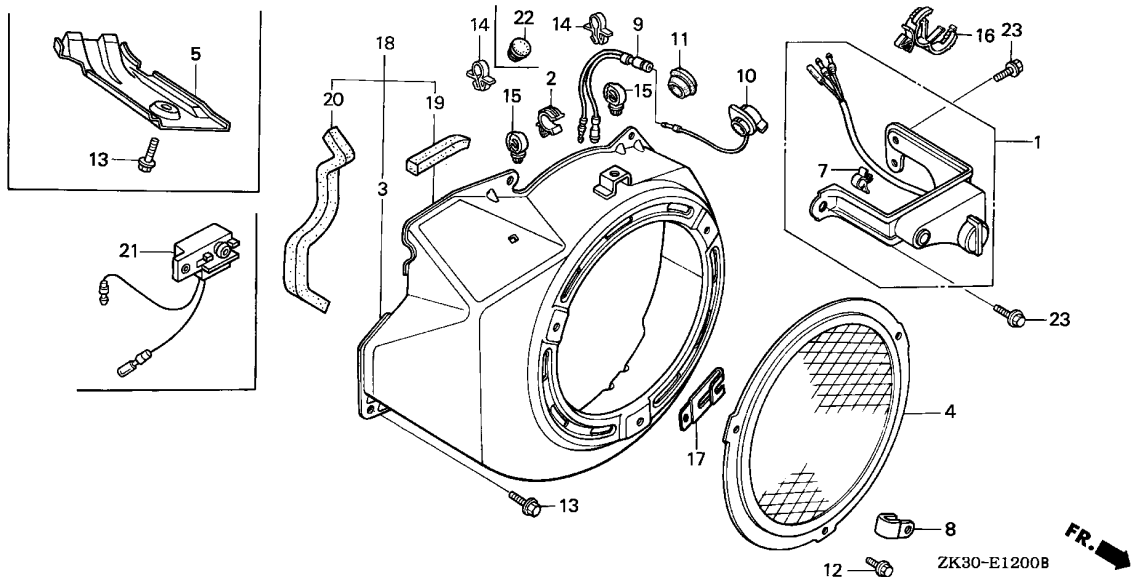

Ref. No.	Part No.	Description	Reqd. QTY			Serial No.	Parts catalogue code
			GX	(1)	(2)		
13	90013-883-000	BOLT, FLANGE, 6X12(CT200) ...	6	-	-	-----	BJ,EDE2,EDE2/A,EDK,EDN,EDN2,EDN2/A,EDN5,EDN5/A,EDS,EDS1,EDS1/A,EDS2,EDS2/A,EDS3,EDS4,EDS6,EDS6/A,EDT,EDT/A,EDT1,EDT1/A,EDT2,EDT3,EDT6,EDT6/A,ED6,ED6/A,ED7,ED8,ED8/A,ED9,ED9/A,EN,ENT,ENT/A,ENT2,EN6,EN6/A,ES,ES1,ES1/A,ES2,ES3,ES3/A,ES4,ES4/A,ET,ETS,ETX,HA,HAQ,HA2,HA2/A,HH,HX,HX2,HX26,HX26/A,LH,LH/A,LHB1,LHB3,LHB3/A,LHC,LHE,LHE/A,LHQ4,LHQ4/A,LHW,LJ,LJ/A,LJG,LJG/A,LJS,LJS1,LKE,LKE/A,LP,LSX,LT,LT/A,LWD,LWD1,LWD1/A,LX,LX/A,LXE,LXE/A,LXE2,LXE2/A,LXE4,LXE4/A,LXE6,LXE8,LXE8/A,LXQ4,LXQ4/A,LXU,LXU/A,LXZ,LX2,LX2/A,LX26,LX26/A,PKT2,PKT2/A,PKT4,PKT4/A,PKX2,PKX4,PKX4/A,PX,PX/A,PXA2,PXE8,PXE8/A,QA,QAB2,QAB2/A,QAC2,QAC2/A,QAE,QAE2,QAE2/A,QAE6,QAE6/A,QAG,QAG/A,QA2,QA2/A,QAP,QAPE,QAPE2,QAPE2/A,QAQ,QA2,QA2/A,QA26,QA26/A,QDW9,QDW9/A,QE,QE/A,QH,QH/A,QHB3,QHB3/A,QHC,QHE,QHE/A,QHP1,QHP1/A,QHQ4,QHQ4/A,QH2,QKA4,QKA4/A,QL2,QMEO,QMEO/A,QME8,QME8/A,QMH,QMH/A,QMT2,QMT2/A,QMX2,QNE,QNE2,QNE2/A,QNE6,QNE9,QNE9/A,QNR2,QNR2/A,QNR6,QNR6/A,QN18,QP,QP/A,QPE2,QT,QT/A,QTC2,QTC2/A,QWH2,QWH2/A,QX,QX/A,QXB,QXB/A,QXB7,QXB7/A,QXC,QXC/A,QXC4,QXC4/A,QXC6,QXC6/A,QXC9,QXC9/A,QXE,QXE/A,QXEB,QXE2,QXE4,QXE4/A,QXE6,QXE6/A,QXE8,QXE8/A,QXQ4,QXQ4/A,QXU,QXU/A,QX2,SDE,SE,SE/A,SH,SH/A,SHB1,SHB3,SHB3/A,SHE,SHEZ,SHQ4,SHQ4/A,SHT,SJ,SJ/A,SJG,SJG/A,SKE,SKE/A,SKZ,SKZ/A,SME0,SME0/A,SME2,SMX2,SMX2/A,STJ,STJ/A,STP,STP/A,STQ,STQ/A,STR,STR/A,SWX,SWX/A,SX,SX/A,SXB,SXB/A,SXB7,SXB7/A,SXE,SXE/A,SXEB,SXEB/A,SXE2,SXE4,SXE4/A,SXE8,SXE8/A,SXP,SXQ4,SXQ4/A,SXU,SXU/A,VA,VA,VA,VAE,VAD2,VAD2/A,VAH1,VAH2,VAW1,VA2,VA2/A,VC2,VC2/A,VDE,VDE2,VDE2/A,VD16,VE,VEB6,VH,VHE,VH12,VH12/A,VH22,VH22/A,VMQ,VMQ,VMQ/A,VMX,VNG,VNG1,VNG2,VSH7,VS2,VS3,VS4,VS5,VS6,VST,VTE2,VVA,VVA2,VVC,VVC2,VVC2/A,VVE,VVE2,VVE2/A,VVS2,VVS2/A,VV12,VV12/A,VX,VX/A,VXA,VXB,VXB/A,VXB2,VXB7,VXB7/A,VXE,VXE/A,VXEB,VXEB/A,VXE2,VXE2/A,VXE4,VXE6,VXE7,VXE7/A,VXE8,VXE8/A,VXG,VXK,VXQ4,VXQ4/A,VXU,VXU/A,VXU1,VXU1/A,VX16,VX16/A,VX8,VX8/A,YJ,ZK1,ZK1/A

Ref. No.	Part No.	Description	Reqd. QTY			Serial No.	Parts catalogue code	
			(1)	(2)	(3)			
13)	90013-883-000	BOLT, FLANGE, 6X12(CT200) ...	-	6	6			
14	90654-SA4-003	CLIP, WIRE HARNESS, 6MM(WHITE)	2	-	-	-----	EDE2,EDE2/A,EDN,EDN2,EDN2/A,EDS,EDS1,EDS1/A,EDS2,EDS2/A,EDS3,EDS4,EDS6,EDS6/A,EDT,EDT/A,EDT1,EDT1/A,EDT2,EDT3,EDT6,EDT6/A,ED6,ED6/A,EMT,EMT/A,ENT,ENT/A,ENT2,EN6,EN6/A,ES3,ES3/A,ES4,ES4/A,VMQ,VMT,VMT/A,VS2,VS3,VS4,VS5,VS6,VS7,VTE2,ZK1/A	
15	90683-SAO-003	CLIP, WIRE HARNESS, 25MM ....	2	-	-	2335944	ZK1	
			2	-	-	-----	2335943 ZK1	
16	90684-ZA0-601	CLIP, HARNESS .....	1	-	-	-----	EDK,EDS2,EDS2/A,EDT1,EDT1/A,EDT2,EDT3,EDT6,EDT6/A,ED6,ED6/A,ED9,ED9/A,EN6,EN6/A,ES1,ES1/A,ES2,HA,HAQ,HA2,HA2/A,HX,HX2,HX26,HX26/A,LX,LX/A,LXQ4,LXQ4/A,LXU,LXU/A,LXZ,LX2,LX2/A,LX26,LX26/A,PKT2,PKT2/A,PX,PX/A,QA,QAB2,QAB2/A,QAC2,QAC2/A,QAG,QAG/A,QAHT,QAHT/A,QAP,QAP2,QAP2/A,QAQ,QA2,QA2/A,QA26,QA26/A,QDW9,QDW9/A,QMT2,QMT2/A,QMX2,QTC2,QTC2/A,QWH2,QWH2/A,QX,QX/A,QXB,QXB/A,QXC,QXC/A,QXC4,QXC4/A,QXC6,QXC6/A,QXC9,QXC9/A,QXQ4,QXQ4/A,QXU,QXU/A,QX2,SHT,SMX2,SMX2/A,SWX,SWX/A,SX,SX/A,SXB,SXB/A,SXP,SXQ4,SXQ4/A,SXU,SXU/A,VA,VAA,VAD2,VAD2/A,VAH1,VAW1,VA2,VA2/A,VC2,VC2/A,VDE,VDE2,VDE2/A,VD16,VH12,VH12/A,VMX,VNG,VNG1,VWC,VWC2,VWC2/A,VWS2,VWS2/A,VW12,VW12/A,VX,VX/A,VXA,VXB,VXB/A,VXB2,VXG,VXK,VXQ4,VXQ4/A,VXU,VXU/A,VX16,VX16/A,VX8,VX8/A	
			1	-	-	2160982	-----	ETX
			-	(1)	1			
17	91406-166-000	CLIP, WIRE .....	1	-	-	-----	ZK1,ZK1/A	
18	19610-ZE3-H51ZA	COVER COMP., FAN *R8*.....BRIGHT RED	1	-	-	-----	LWD1	
	19610-ZE3-H51ZD	*R280*.....POWER RED	1	-	-	3730178	LWD1/A	
			1	-	-	3730179	LWD1/A	
19	19613-ZE3-H50	SEAL, FAN COVER .....	1	-	-	-----	LWD1,LWD1/A	
20	28403-ZE3-H60	SEAL, RECOIL .....	1	-	-	-----	LWD1,LWD1/A	
21	15520-ZB2-003	ALERT UNIT, OIL .....	1	-	-	-----	2143683 ES3	
22	50317-254-000	PLUG, USELESS HOLE .....	-	-	1			
23	90013-883-000	BOLT, FLANGE, 6X12(CT200) ...	2	(2)	-	-----	2143683 ES1,HA,HX,LX,LXZ,L1,PX,P1,QA,QAP,QX,QXB,QXC,Q1,SWX,SX,SXB,SXP,S1,VA,VAA,VAH1,VNG,VNG1,VX,VXA,VXB,V1	



# E-12-1

# FAN COVER(2)

**K 2**

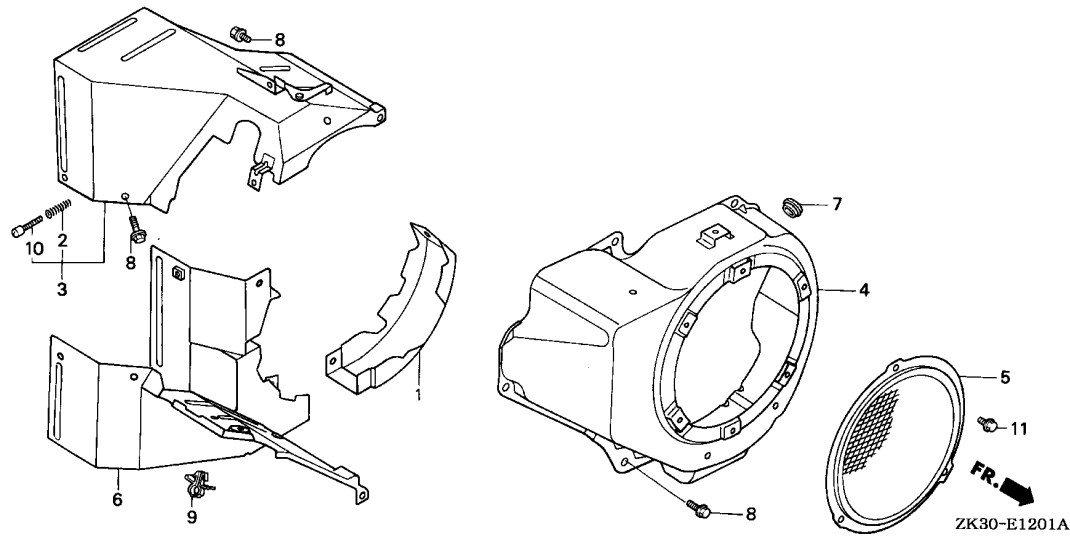

Ref. No.	L.O.N.	(Relative ref. Number) Description	F.R.T.
3	4141E2	SHROUD, ENGINE :UPPER .....	0.3
4	1141G8	COVER, ENGINE COOLING FAN ....	0.2
5	4141C9	PROTECTOR, FAN COVER .....	0.1
6	4141E0	SHROUD, ENGINE :LOWER .....	0.3

**2**

Ref. No.	Part No.	Description	Reqd. QTY			Serial No.	Parts catalogue code
			GX	340K1			
			(1)	(2)	(3)		
1	11315-ZB8-000	SCROLL, GENERATOR FAN .....	1	-	-	-----	EDS5
2	16584-883-300	SPRING, CONTROL ADJUSTING ...	1	-	-	-----	EDS5
3	19602-ZE3-E40	SHROUD ASSY., UPPER .....	1	-	-	-----	EDS5
4	19610-ZB8-000	COVER COMP., FAN .....	1	-	-	-----	EDS5
5	19620-ZE3-810	PROTECTOR COMP., FAN COVER ..	1	-	-	-----	EDS5
6	19630-ZB8-000	SHROUD COMP., LOWER .....	1	-	-	-----	EDS5
7	81329-567-020	GROMMET, DRAIN HOLE .....	1	-	-	-----	EDS5
8	90013-883-000	BOLT, FLANGE, 6X12(CT200) ...	7	-	-	-----	EDS5
9	90654-SA4-003	CLIP, WIRE HARNESS, 6MM(WHITE)	1	-	-	-----	EDS5
10	93500-05032-0A	SCREW, PAN, 5X32 .....	1	-	-	-----	EDS5
11	95701-06008-00	BOLT, FLANGE, 6X8 .....	3	-	-	-----	EDS5

E-14

CARBURETOR(1)

K 3

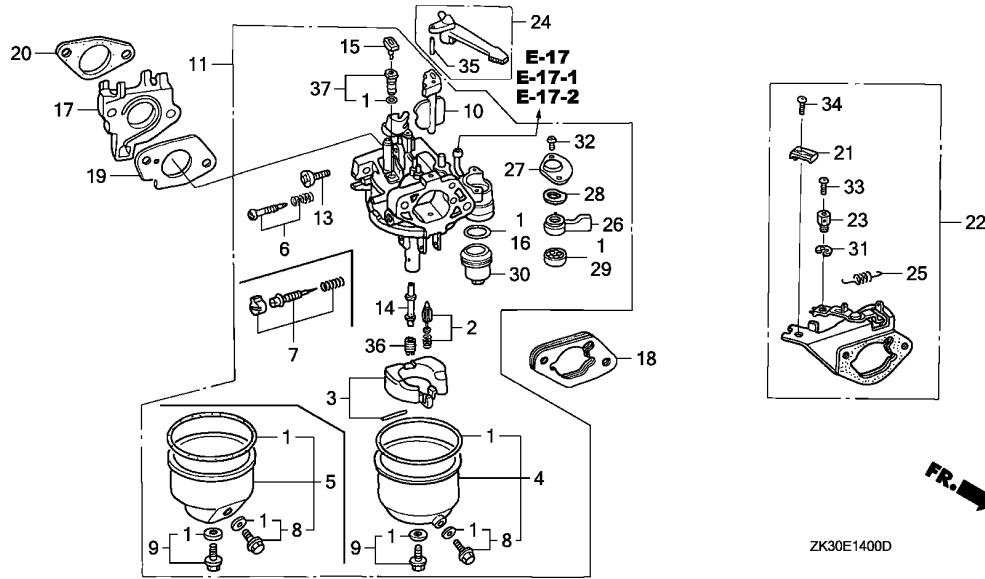

Ref. No.	L.O.N.	(Relative ref. Number) Description	F.R.T.
1	3111B1	GASKET SET, CARBURETOR (3)	0.3
2	3111E1	VALVE SET, FLOAT AND/OR FLOAT SET (5)	0.3
4	3111A3	CHAMBER SET, FLOAT AND/OR GASKET, FLOAT CHAMBER (7)	0.2
6	3111D7	SCREW SET, PILOT	0.2
11	3111F3	CARBURETOR (30)	0.2
16	3101L6	PACKING, FUEL STRAINER CUP (20)	0.2
17	3111C0	INSULATOR, CARBURETOR AND/OR PACKING, INSULATOR	0.2
18	3111D9	SPACER, CARBURETOR	0.2
19	3111C8	PACKING, CARBURETOR	0.2
22	3111G3	STAY, CHOKE CONTROL	0.2
24	8101F9	LEVER, CARBURETOR CHOKE	0.2
25	3111M8	SPRING, CHOKE CONTROL STAY RETURN (26,27,28)	0.1
29	3101C5	PACKING, FUEL COCK	0.2
36	3111C3	JET, MAIN	0.3

Ref. No.	Part No.	Description	Reqd. QTY GX 340K1 (1) (2) (3)	Serial No.	Parts catalogue code		
1	16010-ZE2-812	GASKET SET (INCLUDE 16173-001-004)	1 - -	-----	BJ, EDK, EDN5, EDN5/A, ED7, ED8, ED8/A, ED9, ED9/A, EN, ES, ES1, ES1/A, ES2, ET, ETS, ETX, HA, HAQ, HA2, HA2/A, HH, HX, HX2, HX26, HX26/A, LH, LH/A, LHB1, LHB3, LHB3/A, LHB5, LHC, LHE, LHE/A, LHQ4, LHQ4/A, LHW, LJ, LJ/A, LJG, LJG/A, LJS, LJS/A, LJS1, LKE, LKE/A, LP, LSX, LT, LT/A, LWD, LX, LX/A, LXE, LXE/A, LXE2, LXE2/A, LXE4, LXE4/A, LXE6, LXE8, LXE8/A, LXQ4, LXQ4/A, LXU, LXU/A, LXZ, LXZ/A, LX2/A, LX26, LX26/A, PKT2, PKT2/A, PKT4, PKT4/A, PKX2, PKX4, PKX4/A, PX, PX/A, PXA2, PXE8, PXE8/A, QA, QAB2, QAB2/A, QAC2, QAC2/A, QAE, QAE2, QAE2/A, QAE6, QAE6/A, QAG, QAG/A, QAH2, QAH2/A, QAP, QAPE, QAP2, QAP2/A, QAQ, QA2, QA2/A, QA26, QA26/A, QDW9, QDW9/A, QE, QE/A, QH, QH/A, QHB3, QHB3/A, QHB5, QHC, QHE, QHE/A, QHP1, QHP1/A, QHQ4, QHQ4/A, QH2, QKA4, QKA4/A, QL2, QMEO, QMEO/A, QME8, QME8/A, QMH, QMH/A, QMT2, QMT2/A, QMX2, QNE, QNE2, QNE2/A, QNE6, QNE9, QNE9/A, QNR2, QNR2/A, QNR6, QNR6/A, QN18, QP, QP/A, QPE2, QT, QT/A, QTC2, QTC2/A, QWH2, QWH2/A, QX, QX/A, QXB, QXB/A, QXB7, QXB7/A, QXC, QXC/A, QXC4, QXC4/A, QXC6, QXC6/A, QXC9, QXC9/A, QXE, QXE/A, QXEB, QXE2, QXE4, QXE4/A, QXE6, QXE6/A, QXE8, QXE8/A, QXQ4, QXQ4/A, QXU, QXU/A, QX2, SDE, SE, SE/A, SH, SH/A, SHB1, SHB3, SHB3/A, SHE, SHEZ, SHQ4, SHQ4/A, SHT, SJ, SJ/A, SJG, SJG/A, SKE, SKE/A, SKZ, SKZ/A, SMEO, SMEO/A, SME2, SMX2, SMX2/A, STJ, STJ/A, STP, STP/A, STQ, STQ/A, STR, STR/A, SWX, SWX/A, SX, SX/A, SXB, SXB/A, SXB7, SXB7/A, SXE, SXE/A, SXEB, SXEB/A, SXE2, SXE4, SXE4/A, SXE8, SXE8/A, SXP, SXQ4, SXQ4/A, SXU, SXU/A, VA, VAA, VAAE, VAD2, VAD2/A, VAH1, VAH2, VAW1, VA2, VA2/A, VDE, VDE2, VDE2/A, VD16, VE, VEB6, VH, VHE, VH12, VH12/A, VH22, VH22/A, VMX, VNG, VNG1, VNG2, VSH7, VWA, VWA2, VWC2, VWC2/A, VWE2, VWE2/A, VWS2, VWS2/A, VW12, VW12/A, VX, VX/A, VXA, VXB, VXB/A, VXB2, VXB7, VXB7/A, VXE, VXE/A, VXEB, VXEB/A, VXE2, VXE2/A, VXE4, VXE6, VXE7, VXE7/A, VXE8, VXE8/A, VXG, VXX, VXQ4, VXQ4/A, VXU, VXU/A, VXU1, VXU1/A, VX16, VX16/A, VX8, VX8/A, YJ	- (1) -	

2

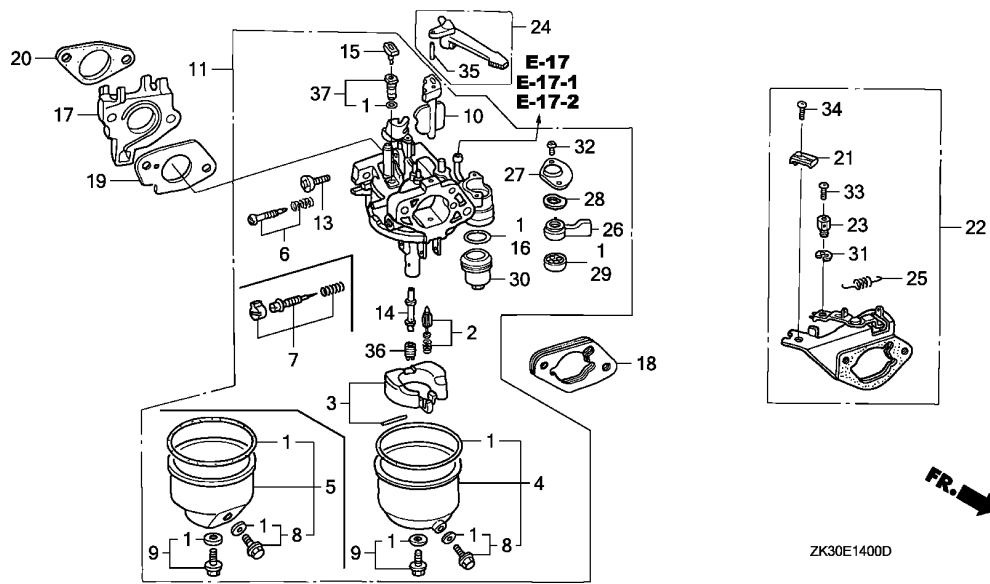

Ref. No.	Part No.	Description	Reqd. QTY			Serial No.	Parts catalogue code
			GX	340K1	(3)		
2	16011-ZA0-931	VALVE SET, FLOAT .....	1	-	-	-----	BJ,EDK,EDN5,EDN5/A,ED7,ED8,ED8/A,ED9,ED9/A,EN,ES,ES1,ES1/A,ES2,ET ETS,ETX,HA,HAQ,HA2,HA2/A,HH,HX,HX2,HX26,HX26/A,LH,LH/A,LHB1,LHB3 LHB3/A,LHB5,LHC,LHE,LHE/A,LHQ4,LHQ4/A,LHW,LJ,LJ/A,LJG,LJG/A,LJS LJS/A,LJS1,LKE,LKE/A,LP,LSX,LT,LT/A,LWD,LX,LX/A,LXE,LXE/A,LXE2 LXE2/A,LXE4,LXE4/A,LXE6,LXE8,LXE8/A,LXQ4,LXQ4/A,LXU,LXU/A,LXZ,LX2 LX2/A,LX26,LX26/A,PKT2,PKT2/A,PKT4,PKT4/A,PKX2,PKX4,PKX4/A,PX PX/A,PXA2,PXE8,PXE8/A,QA,QAB2,QAB2/A,QAC2,QAC2/A,QAE,QAE2,QAE2/A QAE6,QAE6/A,QAG,QAG/A,QA2,QA2/A,QAH2,QAH2/A,QAP,QAPE,QAPE2,QAPE2/A,QAQ,QA2 QA2/A,QA26,QA26/A,QDW9,QDW9/A,QE,QE/A,QH,QH/A,QHB3,QHB3/A,QHB5 QHC,QHE,QHE/A,QHP1,QHP1/A,QHQ4,QHQ4/A,QH2,QKA4,QKA4/A,QL2,QMEO QMEO/A,QME8,QME8/A,QMH,QMH/A,QMT2,QMT2/A,QMX2,QNE,QNE2,QNE2/A QNE6,QNE9,QNE9/A,QNR2,QNR2/A,QNR6,QNR6/A,QN18,QP,QP/A,QPE2,QT QT/A,QTC2,QTC2/A,QWH2,QWH2/A,QX,QX/A,QXB,QXB/A,QXB7,QXB7/A,QXC QXC/A,QXC4,QXC4/A,QXC6,QXC6/A,QXC9,QXC9/A,QXE,QXE/A,QXEB,QXE2 QXE4,QXE4/A,QXE6,QXE6/A,QXE8,QXE8/A,QXQ4,QXQ4/A,QXU,QXU/A,QX2,SDE SE,SE/A,SH,SH/A,SHB1,SHB3,SHB3/A,SHE,SHEZ,SHQ4,SHQ4/A,SHT,SJ,SJ/A SJG,SJG/A,SKE,SKE/A,SKZ,SKZ/A,SMEO,SMEO/A,SMX2,SMX2/A,STJ STJ/A,STP,STP/A,STQ,STQ/A,STR,STR/A,SWX,SWX/A,SX,SX/A,SXB,SXB/A SXB7,SXB7/A,SXE,SXE/A,SXEB,SXEB/A,SXE2,SXE4,SXE4/A,SXE8,SXE8/A SXP,SXQ4,SXQ4/A,SXU,SXU/A,VA,VAA,VAE,VAD2,VAD2/A,VAH1,VAH2,VAW1 VA2,VA2/A,VDE,VDE2,VDE2/A,VD16,VE,VEB6,VH,VHE,VH12,VH12/A,VH22 VH22/A,VMX,VNG,VNG1,VNG2,VSH7,VVA,VVA2,VWC2,VWC2/A,VWE2,VWE2/A VWS2,VWS2/A,VW12,VW12/A,VX,VX/A,VXA,VXB,VXB/A,VXB2,VXB7/VXB7/A VXE,VXE/A,VXEB,VXEB/A,VXE2,VXE2/A,VXE4,VXE6,VXE7,VXE7/A,VXE8 VXE8/A,VXG,VXK,VXQ4,VXQ4/A,VXU,VXU/A,VXU1,VXU1/A,VX16,VX16/A,VX8 VX8/A,YJ

Ref. No.	Part No.	Description	Reqd. QTY			Serial No.	Parts catalogue code
			(1)	(2)	(3)		
3	16013-ZA0-931	FLOAT SET .....	1	-	-	BJ, EDK, EDN5, EDN5/A, ED7, ED8, ED8/A, ED9, ED9/A, EN, ES, ES1, ES1/A, ES2, ET, ETS, ETX, HA, HAQ, HA2, HA2/A, HH, HX, HX2, HX26, HX26/A, LH, LH/A, LHB1, LHB3, LHB3/A, LHB5, LHC, LHE, LHE/A, LHQ4, LHQ4/A, LHW, LJ, LJ/A, LJG, LJG/A, LJS, LJS/A, LJS1, LKE, LKE/A, LP, LSX, LT, LT/A, LWD, LX, LX/A, LXE, LXE/A, LXE2, LXE2/A, LXE4, LXE4/A, LXE6, LXE8, LXE8/A, LXQ4, LXQ4/A, LXU, LXU/A, LXZ, LXZ/A, LX26, LX26/A, PKT2, PKT2/A, PKT4, PKT4/A, PKX2, PKX4, PKX4/A, PX, PX/A, PXA2, PXE8, PXE8/A, QA, QAB2, QAB2/A, QAC2, QAC2/A, QAE, QAE2, QAE2/A, QAE6, QAE6/A, QAG, QAG/A, QAH2, QAH2/A, QAP, QAPE, QAP2, QAP2/A, QAG, QA2, QA2/A, QA26, QA26/A, QDW9, QDW9/A, QE, QE/A, QH, QH/A, QHB3, QHB3/A, QHB5, QHC, QHE, QHE/A, QHP1, QHP1/A, QHQ4, QHQ4/A, QH2, QKA4, QKA4/A, QL2, QMED, QMED/A, QME8, QME8/A, QMH, QMH/A, QMT2, QMT2/A, QMX2, QNE, QNE2, QNE2/A, QNE6, QNE9, QNE9/A, QNR2, QNR2/A, QNR6, QNR6/A, QN18, QP, QP/A, QPE2, QT, QT/A, QTC2, QTC2/A, QWH2, QWH2/A, QX, QX/A, QXB, QXB/A, QXB7, QXB7/A, QXC, QXC/A, QXC4, QXC4/A, QXC6, QXC6/A, QXC9, QXC9/A, QXE, QXE/A, QXEB, QXE2, QXE4, QXE4/A, QXE6, QXE6/A, QXE8, QXE8/A, QXQ4, QXQ4/A, QXU, QXU/A, QX2, SDE, SE, SE/A, SH, SH/A, SHB1, SHB3, SHB3/A, SHE, SHEZ, SHQ4, SHQ4/A, SHT, SJ, SJ/A, SJG, SJG/A, SKE, SKE/A, SKZ, SKZ/A, SMEO, SMEO/A, SME2, SMX2, SMX2/A, STJ, STJ/A, STP, STP/A, STQ, STQ/A, STR, STR/A, SWX, SWX/A, SX, SX/A, SXB, SXB/A, SXB7, SXB7/A, SXE, SXE/A, SXEB, SXEB/A, SXE2, SXE4, SXE4/A, SXE8, SXE8/A, SXP, SXQ4, SXQ4/A, SXU, SXU/A, VA, VAA, VAAE, VAD2, VAD2/A, VAH1, VAH2, VAW1, VA2, VA2/A, VDE, VDE2, VDE2/A, VD16, VE, VEB6, VH, VHE, VH12, VH12/A, VH22, VH22/A, VMX, VNG, VNG1, VNG2, VSH7, VWA, VWA2, VWC2, VWC2/A, VWE2, VWE2/A, VWS2, VWS2/A, VW12, VW12/A, VX, VX/A, VXA, VXB, VXB/A, VXB2, VXB7, VXB7/A, VXE, VXE/A, VXEB, VXEB/A, VXE2, VXE2/A, VXE4, VXE6, VXE7, VXE7/A, VXE8, VXE8/A, VXG, VXX, VXQ4, VXQ4/A, VXU, VXU/A, VXU1, VXU1/A, VX16, VX16/A, VX8, VX8/A, YJ	
4	16015-ZE2-005	CHAMBER SET, FLOAT .....	-	(1)	-		
		(CARBURETOR NO.)	1	(1)	-	BE47A A LHC, L1, P1, QHC, QXC, QXC4, Q1, SHT, S1, V1	
		//	1	-	-	BE34B B BJ, ED7, ED8, ED9, EN, ES, ES1, ET, ETS, ETX, HA, HH, HX, LH, LHB1, LHB3, LHE, LHQ4, LJ, LJG, LKE, LP, LX, LXE, LXE4, LXQ4, LXZ, PX, QA, QAE, QAP, QAPE, QE, QH, QHB3, QHE, QHQ4, QMED, QNE, QN18, QP, QT, QX, QXB, QXE, QXEB, QXE4, QXQ4, SDE, SE, SH, SHB1, SHB3, SHE, SHEZ, SHQ4, SJ, SJG, SKZ, SMEO, STJ, STP, STQ, SWX, SX, SXB, SXE, SXEB, SXE4, SXP, SXQ4, VA, VAA, VAAE, VAH1, VAH2, VAW1, VDE, VD16, VEB6, VH, VHE, VNG, VNG1, VNG2, VWA, VX, VXA, VXB, VXE, VXEB, VXE4, VXG, VXQ4, VXU, VXU1, VX16, YJ	
		//	1	-	-	BE80A A HAQ, QAQ, QNE9	
		//	1	-	-	BE80B A HA2, HX2, HX26, LXE2, LXE6, LX2, LX26, PKT2, QAE2, QAE6, QAP2, QA2, QA26, QH2, QMT2, QNE2, QNE6, QNR2, QNR6, QPE2, QTC2, QXE2, QXE6, QX2, SME2, SMX2, SXE2, VAD2, VA2, VDE2, VH12, VH22, VWA2, VWC2, VWE2, VWS2, VW12, VXB2, VXE2, VXE6	
		//	1	-	-	BE80C A QDW9, QXC6, QXC9	



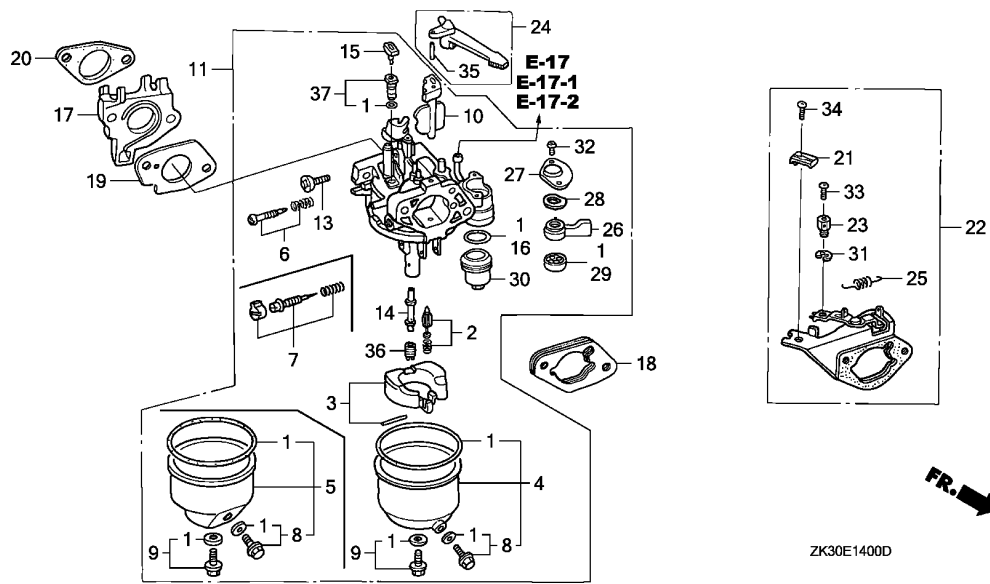

Ref. No.	Part No.	Description	Reqd. QTY			Serial No.	Parts catalogue code
			GX	340K1			
			(1)	(2)	(3)		
5	16015-ZE8-005	CHAMBER SET, FLOAT .....	1	(1)	-	-----	EDK,EDN5,EDN5/A,ED8/A,ED9/A,ES1/A,ES2,HA2/A,HX26/A,LH/A,LHB3/A,LHB5,LHE/A,LHQ4/A,LHW,LJ/A,LJG/A,LJS,LJS/A,LJS1,LKE/A,LSX,LT,LT/A,LWD,LX/A,LXE/A,LXE2/A,LXE4/A,LXE8,LXE8/A,LXQ4/A,LXU,LXU/A,LX2/A,LX26/A,L1/A,PKT2/A,PKT4,PKT4/A,PKX2,PKX4,PKX4/A,PX/A,PXA2,PXE8,PXE8/A,P1/A,QAB2,QAB2/A,QAC2,QAC2/A,QAE2/A,QAE6/A,QAG,QAG/A,QA2,QA2/A,QAP2/A,QA2/A,QA26/A,QDW9/A,QE/A,QH/A,QHB3/A,QHB5,QHE/A,QHP1,QHP1/A,QHQ4/A,QKA4,QKA4/A,QL2,QMEO/A,QME8,QME8/A,QMH,QMH/A,QMT2/A,QMX2,QNE2/A,QNE9/A,QNR2/A,QNR6/A,QP/A,QT/A,QTC2/A,QWH2,QWH2/A,QX/A,QXB/A,QXB7,QXB7/A,QXC/A,QXC4/A,QXC6/A,QXC9/A,QXE/A,QXE4/A,QXE6/A,QXE8,QXE8/A,QXQ4/A,QXU,QXU/A,Q1/A,SE/A,SH/A,SHB3/A,SHQ4/A,SJ/A,SJG/A,SKE,SKE/A,SKZ/A,SMEO/A,SMX2/A,STJ/A,STP/A,STQ/A,STR,STR/A,SWX/A,SX/A,SXB/A,SXB7,SXB7/A,SXE/A,SXEB/A,SXE4/A,SXE8,SXE8/A,SXQ4/A,SXU,SXU/A,S1/A,VAD2/A,VA2/A,VDE2/A,VH12/A,VH22/A,VMX,VSH7,VWC2/A,VWE2/A,VWS2/A,VW12/A,VX/A,VXB/A,VXB7,VXB7/A,VXE/A,VXE8/A,VXE8/A,VXE7,VXE7/A,VXE8,VXE8/A,VXK,VXQ4/A,VXU/A,VXU1/A,VX16/A,VX8,VX8/A



Ref. No.	Part No.	Description	Reqd. QTY			Serial No.	Parts catalogue code
			(1)	(2)	(3)		
(5)	16015-ZE8-005	CHAMBER SET, FLOAT ..... (CARBURETOR NO.) //	1	(1)	-	BE47A B -----	LHC,L1,P1,QHC,QXC,QXC4,Q1,SHT,S1,V1
			1	-	-	BE34B C -----	BJ,ED7,ED8,ED9,EN,ES,ES1,ET,ETS,ETX,HA,HH,HX,LH,LHB1,LHB3,LHE LHQ4,LJ,LJG,LKE,LP,LX,LXE,LXE4,LXQ4,LXZ,PX,QA,QAE,QAP,QAPE,QE,QH QHB3,QHE,QHQ4,QMED,QNE,QN18,QP,QT,QX,QXB,QXE,QXEB,QXE4,QXQ4,SDE SE,SH,SHB1,SHB3,SHE,SHEZ,SHQ4,SJ,SJG,SKZ,SMED,STJ,STP,STQ,SWX,SX SXB,SXE,SXEB,SXE4,SXP,SXQ4,VA,VAA,VAAE,VAH1,VAH2,VAW1,VDE,VD16,VE VEB6,VH,VHE,VNG,VNG1,VNG2,VWA,VX,VXA,VXB,VXE,VXEB,VXE4,VXG,VXQ4 VXU,VXU1,VX16,YJ
		//	1	-	-	BE80A B -----	HAQ,QAQ,QNE9
		//	1	-	-	BE80B B -----	HA2,HX2,HX26,LXE2,LXE6,LX2,LX26,PKT2,QAE2,QAE6,QAP2,QA2,QA26,QH2 QMT2,QNE2,QNE6,QNR2,QNR6,QPE2,QTC2,QXE2,QXE6,QX2,SME2,SMX2,SXE2 VAD2,VA2,VDE2,VH12,VH22,VWA2,VWC2,VWE2,VWS2,VW12,VXB2,VXE2,VXE6 QDW9,QXC6,QXC9
		//	1	-	-	BE80C B -----	QDW9,QXC6,QXC9
6	16016-ZE0-005	SCREW SET, PILOT ..... (CARBURETOR NO.) //	1	(1)	-	-----	BJ,HA,HH,HX,LHC,LHW,LSX,LT,LXZ,L1,PXE8,P1,QA,QAE,QAP,QAPE,QHC QKA4,QME8,QNE,QP,QT,QXC4,QXEB,Q1,SHEZ,STJ,SWX,SXP,S1,VAH1,VAH2 VAW1,VDE,VWA,V1,YJ
		//	1	(1)	-	BE47A B -----	L1/A,P1/A,QXC,QXC4/A,Q1/A,S1/A
		//	1	-	-	BE34B C -----	ED7,ED8,ED9,EN,ES,ES1,ET,ETS,ETX,LH,LHB1,LHB3,LHE,LHQ4,LJ,LJG,LKE LT/A,LX,LXE,LXE4,LXE8,LXQ4,LXU,PKX4,PX,PXE8/A,QE,QH,QHB3,QHE,QHP1 QHQ4,QKA4/A,QMED,QME8/A,QMH,QN18,QP/A,QT/A,QX,QXB,QXE,QXE4,QXE8 QXQ4,QXU,SDE,SE,SH,SHB1,SHB3,SHE,SHQ4,SHT,SJ,SJG,SKE,SKZ,SMED STJ/A,STP,STQ,STR,SWX/A,SX,SXB,SXE,SXEB,SXE4,SXE8,SXQ4,SXU,VA,VAA VAAE,VD16,VE,VEB6,VH,VHE,VNG,VNG1,VNG2,VX,VXA,VXB,VXE,VXEB,VXE4 VXG,VXQ4,VXU,VXU1,VX16
		//	-	(1)	-	BE34B C -----	L1/A,P1/A,Q1/A,S1/A
	16016-ZF6-005	SCREW SET ..... (CARBURETOR NO.) //	1	-	-	BE34C B -----	ED7,ED9,EN,ES,ET,ETS,ETX,VA,VAA,VAAE,VD16,VE,VEB6,VH,VHE,VNG,VNG1 VNG2,VXA,VXE4,VXG
		//	1	-	-	BE34C B -----	EDN5,ED9/A,VMX,VXE8,VX8
		//	1	-	-	BE34C B -----	BE34C B ED8,ES1,VX,VXB,VXE,VXEB,VXQ4,VXU,VXU1,VX16
	16016-ZA0-931	SCREW SET, PILOT ..... //	1	-	-	-----	LP



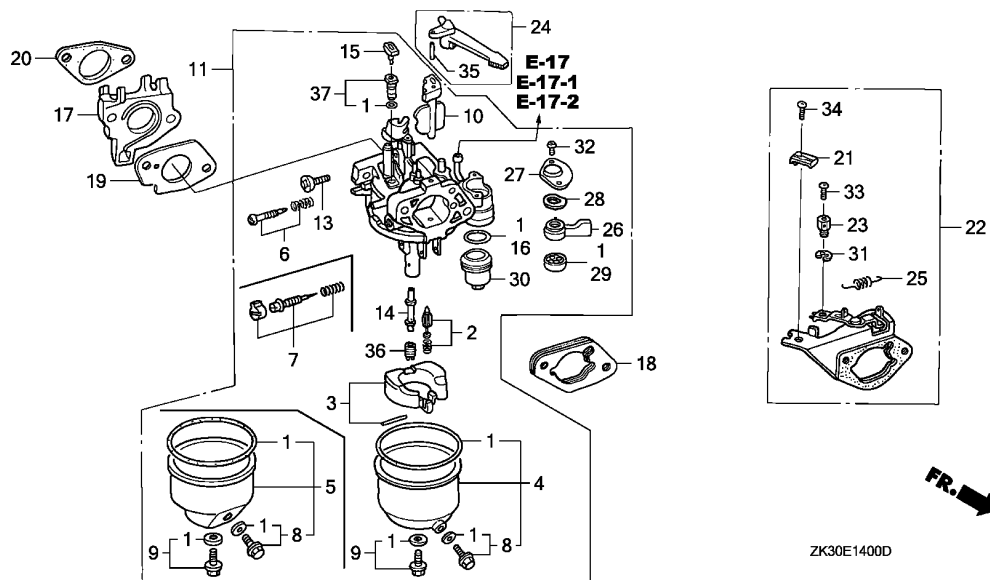

2

Ref. No.	Part No.	Description	Reqd. QTY			Serial No.	Parts catalogue code
			GX	340K1	(3)		
7	16016-ZH7-W01	SCREW SET, PILOT (CARBURETOR NO.)	1	(1)	-	BE34B D	LT/A, L1/A, PXE8/A, P1/A, QKA4/A, QME8/A, QP/A, QT/A, Q1/A, STJ/A, SWX/A, S1/A
			1	-	-		EDK, EDN5/A, ED8/A, ES1/A, ES2, HAQ, HA2, HA2/A, HX2, HX26, HX26/A, LH/A, LHB3/A, LHB5, LHE/A, LHQ4/A, LJ/A, LJG/A, LJS, LJS/A, LJS1, LKE/A, LWD, LX/A, LXE/A, LXE2, LXE2/A, LXE4/A, LXE6, LXE8/A, LXQ4/A, LXU/A, LX2, LX2/A, LX26, LX26/A, PKT2, PKT2/A, PKT4, PKT4/A, PKX2, PKX4/A, PX/A, PXA2, QAB2, QAB2/A, QAC2, QAC2/A, QAE2, QAE2/A, QAE6, QAE6/A, QAG, QAG/A, QAH2, QAH2/A, QAP2, QAP2/A, QAQ, QA2, QA2/A, QA26, QA26/A, QDW9, QDW9/A, QE/A, QH/A, QHB3/A, QHB5, QHE/A, QHP1/A, QHQ4/A, QH2, QL2, QMED/A, QMH/A, QMT2, QMT2/A, QMX2, QNE2, QNE2/A, QNE6, QNE9, QNE9/A, QNR2, QNR2/A, QNR6, QNR6/A, QPE2, QTC2, QTC2/A, QWH2, QWH2/A, QX/A, QXB/A, QXB7, QXB7/A, QXC/A, QXC6, QXC6/A, QXC9, QXC9/A, QXE/A, QXE2, QXE4/A, QXE6, QXE6/A, QXE8/A, QXQ4/A, QXU/A, QX2, SE/A, SH/A, SHB3/A, SHQ4/A, SJ/A, SJG/A, SKE/A, SKZ/A, SMED/A, SME2, SMX2, SMX2/A, STP/A, STQ/A, STR/A, SX/A, SXB/A, SXB7, SXB7/A, SXE/A, SXEB/A, SXE2, SXE4/A, SXE8/A, SXQ4/A, SXU/A, VAD2, VAD2/A, VA2, VA2/A, VDE2, VDE2/A, VH12, VH12/A, VH22, VH22/A, VSH7, VMA2, VWC2, VWC2/A, VWE2, VWE2/A, VWS2, VWS2/A, VW12, VW12/A, VX/A, VXB/A, VXB7, VXB7/A, VXE/A, VXEB/A, VXE2, VXE2/A, VXE6, VXE7, VXE7/A, VXE8/A, VXX, VXQ4/A, VXU/A, VXU1/A, VX16/A, VX8/A
		(CARBURETOR NO.)	1	-	-	BE34C C	ED9/A
		//	1	-	-	BE47A C	QXC4/A
		//	1	-	-	BE80B B	LH, LHB3, LHE, LHQ4, LJ, LJG, LKE, LX, LXE, LXE4, LXE8, LXQ4, LXU, PKX4, PX, QE, QH, QHB3, QHE, QHP1, QHQ4, QMED, QMH, QN18, QX, QXE, QXE4, QXE8, QXQ4, QXU, SDE, SE, SH, SHB1, SHB3, SHE, SHQ4, SJ, SJG, SKE, SKZ, SMED, STP, STQ, STR, SX, SXE, SXE4, SXE8, SXQ4, SXU, VD16, VEB6, VX16
		//	1	-	-	BE80C B	QXC
		//	1	-	-	BE80D B	EDN5, ED7, ED8, ES1, QXB, SXB, SXEB, VH, VMX, VX, VXB, VXE, VXEB, VXE4, VXE8, VXQ4, VXU, VXU1, VX8
		//	-	(1)	-	BE47A C	L1/A, P1/A, Q1/A, S1/A

Ref. No.	Part No.	Description	Reqd. QTY			Serial No.	Parts catalogue code
			(1)	(2)	(3)		
8	16024-ZE1-811	SCREW SET, DRAIN .....	1	-	-	-----	BJ, EDK, EDN5, EDN5/A, ED7, ED8, ED8/A, ED9, ED9/A, EN, ES, ES1, ES1/A, ES2, ET, ETS, ETX, HA, HAQ, HA2, HA2/A, HH, HX, HX2, HX26, HX26/A, LH, LH/A, LHB1, LHB3, LHB3/A, LHB5, LHC, LHE, LHE/A, LHQ4, LHQ4/A, LHW, LJ, LJ/A, LJG, LJG/A, LJS, LJS/A, LJS1, LKE, LKE/A, LP, LSX, LT, LT/A, LWD, LX, LX/A, LXE, LXE/A, LXE2, LXE2/A, LXE4, LXE4/A, LXE6, LXE8, LXE8/A, LXQ4, LXQ4/A, LXU, LXU/A, LXZ, LXZ/A, LX2/A, LX26, LX26/A, PKT2, PKT2/A, PKT4, PKT4/A, PKX2, PKX4, PKX4/A, PX, PX/A, PXA2, PXE8, PXE8/A, QA, QAB2, QAB2/A, QAC2, QAC2/A, QAE, QAE2, QAE2/A, QAE6, QAE6/A, QAG, QAG/A, QAH2, QAH2/A, QAP, QAPE, QAP2, QAP2/A, QAQ, QA2, QA2/A, QA26, QA26/A, QDW9, QDW9/A, QE, QE/A, QH, QH/A, QHB3, QHB3/A, QHB5, QHC, QHE, QHE/A, QHP1, QHP1/A, QHQ4, QHQ4/A, QH2, QKA4, QKA4/A, QL2, QMEO, QMEO/A, QME8, QME8/A, QMH, QMH/A, QMT2, QMT2/A, QMX2, QNE, QNE2, QNE2/A, QNE6, QNE9, QNE9/A, QNR2, QNR2/A, QNR6, QNR6/A, QN18, QP, QP/A, QPE2, QT, QT/A, QTC2, QTC2/A, QWH2, QWH2/A, QX, QX/A, QXB, QXB/A, QXB7, QXB7/A, QXC, QXC/A, QXC4, QXC4/A, QXC6, QXC6/A, QXC9, QXC9/A, QXE, QXE/A, QXEB, QXE2, QXE4, QXE4/A, QXE6, QXE6/A, QXE8, QXE8/A, QXQ4, QXQ4/A, QXU, QXU/A, QX2, SDE, SE, SE/A, SH, SH/A, SHB1, SHB3, SHB3/A, SHE, SHEZ, SHQ4, SHQ4/A, SHT, SJ, SJ/A, SJG, SJG/A, SKE, SKE/A, SKZ, SKZ/A, SMEO, SMEO/A, SME2, SMX2, SMX2/A, STJ, STJ/A, STP, STP/A, STQ, STQ/A, STR, STR/A, SWX, SWX/A, SX, SX/A, SXB, SXB/A, SXB7, SXB7/A, SXE, SXE/A, SXEB, SXEB/A, SXE2, SXE4, SXE4/A, SXE8, SXE8/A, SXP, SXQ4, SXQ4/A, SXU, SXU/A, VA, VAA, VAAE, VAD2, VAD2/A, VAH1, VAH2, VAW1, VA2, VA2/A, VDE, VDE2, VDE2/A, VD16, VE, VEB6, VH, VHE, VH12, VH12/A, VH22, VH22/A, VMX, VNG, VNG1, VNG2, VSH7, VWA, VWA2, VWC2, VWC2/A, VWE2, VWE2/A, VWS2, VWS2/A, VW12, VW12/A, VX, VX/A, VXA, VXB, VXB/A, VXB2, VXB7, VXB7/A, VXE, VXE/A, VXE8, VXE8/A, VXE2, VXE2/A, VXE4, VXE6, VXE7, VXE7/A, VXE8, VXE8/A, VXG, VXX, VXQ4, VXQ4/A, VXU, VXU/A, VXU1, VXU1/A, VX16, VX16/A, VX8, VX8/A, YJ
9	16028-ZE0-005	SCREW SET .....	1	(1)	-	-----	BJ, EDK, EDN5, EDN5/A, ED7, ED8, ED8/A, ED9, ED9/A, EN, ES, ES1, ES1/A, ES2, ET, ETS, ETX, HA, HAQ, HA2, HA2/A, HH, HX, HX2, HX26, HX26/A, LH, LH/A, LHB1, LHB3, LHB3/A, LHB5, LHC, LHE, LHE/A, LHQ4, LHQ4/A, LHW, LJ, LJ/A, LJG, LJG/A, LJS, LJS/A, LJS1, LKE, LKE/A, LP, LSX, LT, LT/A, LWD, LX, LX/A, LXE, LXE/A, LXE2, LXE2/A, LXE4, LXE4/A, LXE6, LXE8, LXE8/A, LXQ4, LXQ4/A, LXU, LXU/A, LXZ, LXZ/A, LX2/A, LX26, LX26/A, PKT2, PKT2/A, PKT4, PKT4/A, PKX2, PKX4, PKX4/A, PX, PX/A, PXA2, PXE8, PXE8/A, QA, QAB2, QAB2/A, QAC2, QAC2/A, QAE, QAE2, QAE2/A, QAE6, QAE6/A, QAG, QAG/A, QAH2, QAH2/A, QAP, QAPE, QAP2, QAP2/A, QAQ, QA2, QA2/A, QA26, QA26/A, QDW9, QDW9/A, QE, QE/A, QH, QH/A, QHB3, QHB3/A, QHB5, QHC, QHE, QHE/A, QHP1, QHP1/A, QHQ4, QHQ4/A, QH2, QKA4, QKA4/A, QL2, QMEO, QMEO/A, QME8, QME8/A, QMH, QMH/A, QMT2, QMT2/A, QMX2, QNE, QNE2, QNE2/A, QNE6, QNE9, QNE9/A, QNR2, QNR2/A, QNR6, QNR6/A, QN18, QP, QP/A, QPE2, QT, QT/A, QTC2, QTC2/A, QWH2, QWH2/A, QX, QX/A, QXB, QXB/A, QXB7, QXB7/A, QXC, QXC/A, QXC4, QXC4/A, QXC6, QXC6/A, QXC9, QXC9/A, QXE, QXE/A, QXEB, QXE2, QXE4, QXE4/A, QXE6, QXE6/A, QXE8, QXE8/A, QXQ4, QXQ4/A, QXU, QXU/A, QX2, SDE, SE, SE/A, SH, SH/A, SHB1, SHB3, SHB3/A, SHE, SHEZ, SHQ4, SHQ4/A, SHT, SJ, SJ/A, SJG, SJG/A, SKE, SKE/A, SKZ, SKZ/A, SMEO, SMEO/A, SME2, SMX2, SMX2/A, STJ, STJ/A, STP, STP/A, STQ, STQ/A, STR, STR/A, SWX, SWX/A, SX, SX/A, SXB, SXB/A, SXB7, SXB7/A, SXE, SXE/A, SXEB, SXEB/A, SXE2, SXE4, SXE4/A, SXE8, SXE8/A, SXP, SXQ4, SXQ4/A, SXU, SXU/A, VA, VAA, VAAE, VAD2, VAD2/A, VAH1, VAH2, VAW1, VA2, VA2/A, VDE, VDE2, VDE2/A, VD16, VE, VEB6, VH, VHE, VH12, VH12/A, VH22, VH22/A, VMX, VNG, VNG1, VNG2, VSH7, VWA, VWA2, VWC2, VWC2/A, VWE2, VWE2/A, VWS2, VWS2/A, VW12, VW12/A, VX, VX/A, VXA, VXB, VXB/A, VXB2, VXB7, VXB7/A, VXE, VXE/A, VXE8, VXE8/A, VXE2, VXE2/A, VXE4, VXE6, VXE7, VXE7/A, VXE8, VXE8/A, VXG, VXX, VXQ4, VXQ4/A, VXU, VXU/A, VXU1, VXU1/A, VX16, VX16/A, VX8, VX8/A, YJ
10	16044-ZE2-005	CHOKE SET .....	1	(1)	-	-----	LP



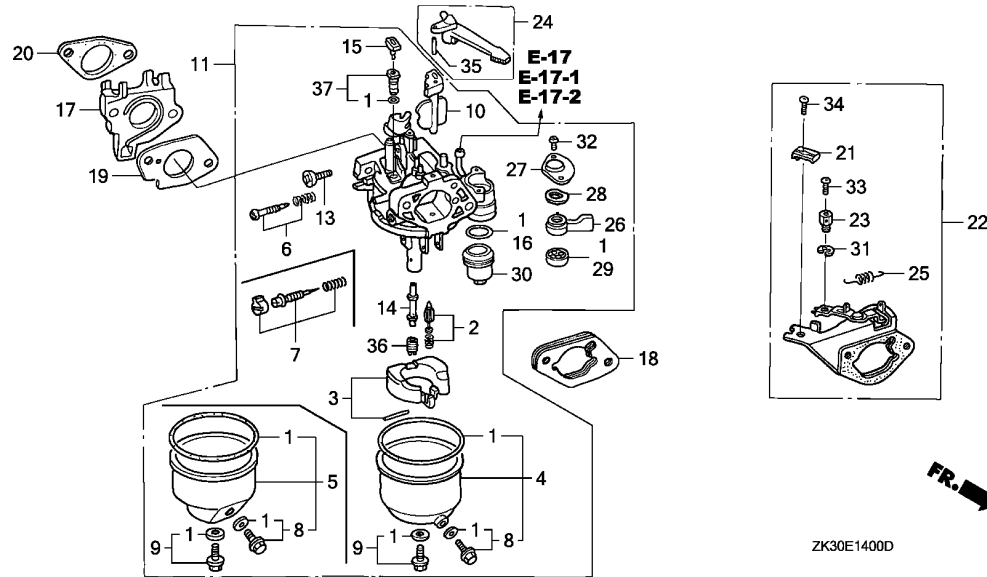

Ref. No.	Part No.	Description	Reqd. QTY			Serial No.	Parts catalogue code
			GX	340K1			
			(1)	(2)	(3)		
10)	16044-ZE3-W20	CHOKE SET .....	1	-	-	-----	BJ,HA,HH,HX,LHB1,LHC,LHW,LSX,LT,LT/A,LXZ,PXE8,PXE8/A,QA,QAE,QAP,QAPE,QHC,QKA4,QKA4/A,QME8,QME8/A,QNE,QP,QP/A,QT,QT/A,QXC4,QXC4/A,QXEB,SHEZ,SHT,STJ,STJ/A,SWX,SWX/A,SXP,VAH1,VAH2,VAW1,VDE,VWA,YJ,ED7,ED8,ED9,EN,ES,ES1,ET,ETS,ETX,LH,LHB3,LHE,LHQ4,LJ,LJG,LKE,LX,LXE,LXE4,LXE8,LXQ4,LXU,PKX4,PX,QE,QH,QHB3,QHE,QHP1,QHQ4,QMEO,QMH,QN18,QX,QXB,QXE,QXE4,QXE8,QXQ4,QXU,SDE,SE,SH,SHB1,SHB3,SHE,SHQ4,SJ,SJG,SKE,SKZ,SME0,STP,STQ,STR,SX,SXB,SXE,SXEB,SXE4,SXE8,SXQ4,SXU,VA,VAA,VAAE,VD16,VE,VEB6,VH,VHE,VNG,VNG1,VNG2,VX,VXA,VXB,VXE,VXEB,VXE4,VXG,VXQ4,VXU,VXU1,VX16
		(CARBURETOR NO.)	1	-	-	-----	BE34B C
		..	1	-	-	-----	BE47A B QXC
			-	(1)	-	-----	

Ref. No.	Part No.	Description	Reqd. QTY			Serial No.	Parts catalogue code
			(1)	(2)	(3)		
10)	16044-ZE3-811	CHOKE SET .....	1	-	-	-----	EDN5/A,ED8/A,ES1/A,ES2,HAQ,HA2,HA2/A,HX2,HX26,HX26/A,LH/A,LHB3/A,LHB5,LHE/A,LHQ4/A,LJ/A,LJG/A,LJS,LJS/A,LJS1,LKE/A,LWD,LX/A,LXE/A,LXE2,LXE2/A,LXE4/A,LXE6,LXE8/A,LXQ4/A,LXU/A,LX2,LX2/A,LX26,LX26/A,PKT2,PKT2/A,PKT4,PKT4/A,PKX2,PKX4/A,PX/A,PXA2,QAB2,QAB2/A,QAC2,QAC2/A,QAE2,QAE2/A,QAE6,QAE6/A,QAG,QAG/A,QA2,QA2/A,QAP2,QAP2/A,QAQ,QA2,QA2/A,QA26,QA26/A,QDW9,QDW9/A,QE/A,QH/A,QHB3/A,QHB5,QHE/A,QHP1/A,QHQ4/A,QH2,QL2,QMEO/A,QMH/A,QMT2,QMT2/A,QMX2,QNE2,QNE2/A,QNE6,QNE9,QNE9/A,QNR2,QNR2/A,QNR6,QNR6/A,QPE2,QTC2,QTC2/A,QWH2,QWH2/A,QX/A,QXB/A,QXB7,QXB7/A,QXC/A,QXC6,QXC6/A,QXC9,QXC9/A,QXE/A,QXE2,QXE4/A,QXE6,QXE6/A,QXE8/A,QXQ4/A,QXU/A,QX2,SE/A,SH/A,SHB3/A,SHQ4/A,SJ/A,SJG/A,SKE/A,SKZ/A,SMEO/A,SME2,SMX2,SMX2/A,STP/A,STQ/A,STR/A,SX/A,SXB/A,SXB7,SXB7/A,SXE/A,SXEB/A,SXE2,SXE4/A,SXE8/A,SXQ4/A,SXU/A,VAD2,VAD2/A,VA2,VA2/A,VDE2,VDE2/A,VH12,VH12/A,VH22,VH22/A,VSH7,VWA2,VWC2,VWC2/A,VWE2,VWE2/A,VWS2,VWS2/A,VW12,VW12/A,VX/A,VXB/A,VXB2,VXB7,VXB7/A,VXE/A,VXEB/A,VXE2,VXE2/A,VXE6,VXE7,VXE7/A,VXE8/A,VXK,VXQ4/A,VXU/A,VXU1/A,VX16/A,VX8/A
		(CARBURETOR NO.)	1	-	-	BE80B B -----	LH,LHB3,LHE,LHQ4,LJ,LJG,LKE,LX,LXE,LXE4,LXE8,LXQ4,LXU,PKX4,PX,QE,QH,QHB3,QHE,QHP1,QHQ4,QMEO,QMH,QN18,QX,QXE,QXE4,QXE8,QXQ4,QXU,SDE,SE,SH,SHB1,SHB3,SHE,SHQ4,SJ,SJG,SKE,SKZ,SMEO,STP,STQ,STR,SX,SXE,SXE4,SXE8,SXQ4,SXU,VD16,VEB6,VX16
		//	1	-	-	BE80C B -----	QXC
		//	1	-	-	BE80D B -----	EDN5,ED7,ED8,ES1,QXB,SXB,SXEB,VH,VMX,VX,VXB,VXE,VXEB,VXE4,VXE8,VXQ4,VXU,VXU1,VX8
11	16100-ZE3-V00	CARBURETOR ASSY. (BE80B A) ..	1	-	-	-----	2519695 HA2,HX2,HX26,LXE2,LXE6,LX2,LX26,PKT2,QAE2,QAE6,QAP2,QA2,QA26,QH2,QMT2,QNE2,QNE6,QNR2,QNR6,QPE2,QTC2,QXE2,QXE6,QX2,SME2,SMX2,SXE2,VAD2,VA2,VDE2,VH12,VH22,VWA2,VWC2,VWE2,VWS2,VW12,VXB2,VXE2,VXE6
	16100-ZE3-W10	CARBURETOR ASSY. (BE47A A) ..	1	(1)	-	-----	2519621 LHC,QHC,QXC,QXC4,Q1,SHT,S1
	16100-ZE3-W11	CARBURETOR ASSY. (BE47A B) ..	1	(1)	-	-----	2519622 LHC,QHC,QXC4,Q1,SHT,S1
			1	-	-	-----	3852703 QXC4/A
			1	-	-	-----	3032023 QXC
			1	(1)	-	-----	3858557 Q1/A,S1/A
	16100-ZE3-W30	CARBURETOR ASSY. (BE34B B) ..	1	(1)	-	-----	2521202 BJ,ED7,ED8,ED9,EN,ES,ES1,ET,ETS,ETX,HA,HH,HX,LH,LHB1,LHB3,LHE,LHQ4,LJ,LJG,LKE,LX,LXE,LXE4,LXQ4,LXZ,L1,PX,P1,QA,QAE,QAP,QAPE,QE,QH,QHB3,QHE,QHQ4,QMEO,QNE,QN18,QP,QT,QX,QXB,QXE,QXEB,QXE4,QXQ4,Q1,SDE,SE,SH,SHB1,SHB3,SHE,SHEZ,SHQ4,SJ,SJG,SKZ,SMEO,STJ,STP,STQ,SWX,SX,SXB,SXE,SXEB,SXE4,SXP,SXQ4,S1,VA,VAA,VAE,VAH1,VAH2,VAW1,VDE,VD16,VE,VEB6,VH,VHE,VNG,VNG1,VNG2,VWA,VX,VXA,VXB,VXE,VXEB,VXE4,VXG,VXQ4,VXU,VXU1,VX16,V1,YJ
	16100-ZE3-W31	CARBURETOR ASSY. (BE34B C) ..	1	(1)	-	-----	2521203 BJ,HA,HH,HX,LHB1,LXZ,L1,P1,QA,QAE,QAP,QAPE,QNE,QP,QT,QXEB,Q1,SHEZ,STJ,SWX,SXP,S1,VAH1,VAH2,VAW1,VDE,VWA,V1,YJ
			1	(1)	-	-----	3852703 LT/A,L1/A,PXE8/A,P1/A,QKA4/A,QME8/A,QP/A,QT/A,Q1/A,STJ/A,SWX/A,S1/A
			1	-	-	-----	LHW,LSX,LT,PXE8,QKA4,QME8
			1	-	-	-----	3032023 LXE8,LXU,QHP1,QMH,QXE8,QXU,SKE,STR,SXE8,SXU
			1	-	-	-----	3129573 PKX4
			1	-	-	-----	2521203 2589543 ED7,ED8,ED9,EN,ES,ES1,ET,ETS,ETX,VA,VAA,VAE,VD16,VE,VEB6,VH,VHE,VNG,VNG1,VNG2,VX,VXA,VXB,VXE,VXEB,VXE4,VXG,VXQ4,VXU,VXU1,VX16
			1	-	-	-----	2521203 3032023 LH,LHB3,LHE,LHQ4,LJ,LJG,LKE,LX,LXE,LXE4,LXQ4,PX,QE,QH,QHB3,QHE,QHQ4,QMEO,QN18,QX,QXB,QXE,QXE4,QXQ4,SDE,SE,SH,SHB1,SHB3,SHE,SHQ4,SJ,SJG,SKZ,SMEO,STP,STQ,SX,SXB,SXE,SXEB,SXE4,SXQ4
	16100-ZE3-W50	CARBURETOR ASSY. (BE80A A) ..	1	-	-	-----	2521899 HAQ,QAQ,QNE9
	16100-ZE3-W51	CARBURETOR ASSY. (BE80A B) ..	1	-	-	-----	QNE9/A
			1	-	-	-----	2521900 HAQ,QAQ,QNE9



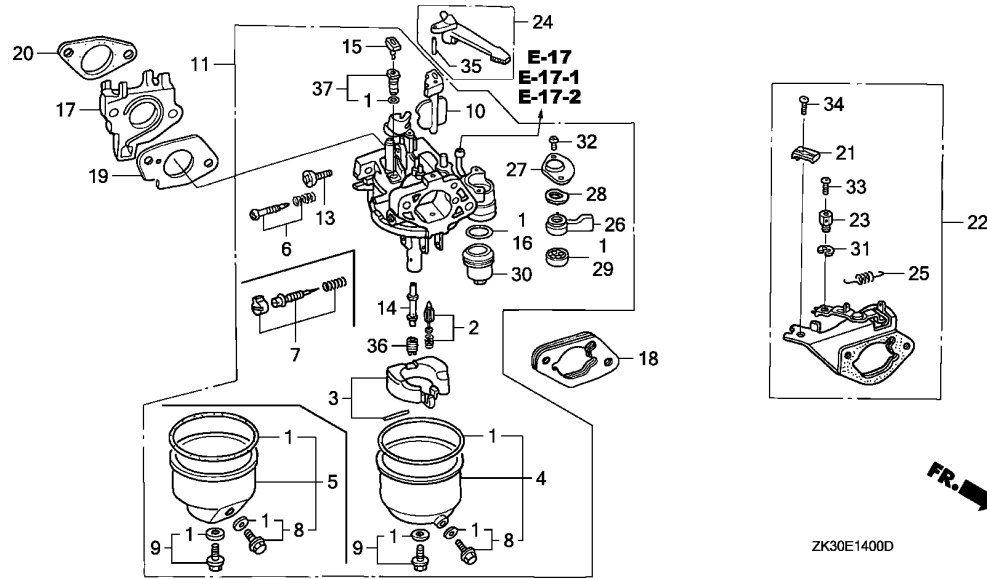

Ref. No.	Part No.	Description	Reqd. QTY			Serial No.	Parts catalogue code
			GX	(1)	(2)		
11)	16100-ZE3-D51	CARBURETOR ASSY. (BE34C B) ..	1	-	-	2589544	ED9,EN,ES,ET,ETS,ETX,VA,VAA,VA AE,VE,VHE,VNG,VNG1,VNG2,VXA,VXG
			1	-	-	3032023	EDN5,VMX,VXE8,VX8
			1	-	-	3858557	ED9/A
			1	-	-	2589544	2701601
			1	-	-	2589544	3032023
	16100-ZE3-V01	CARBURETOR ASSY. (BE80B B) ..	1	-	-		ED7,ED8,ES1,VH,VX,VXB,VXE,VXE B,VXE4,VXQ4,VXU,VXU1
			1	-	-		HA2/A,HX26/A,LH/A,LHB3/A,LHB5,LHE/A,LHQ4/A,LJ/A,LJG/A,LJS,LJS/A
			1	-	-		LX26/A,PKT2/A,PKT4,PKT4/A,PKX2,PKX4/A,PX/A,PXA2,QAB2,QAB2/A,QAC2
			1	-	-		QAC2/A,QAE2/A,QAE6/A,QAG,QAG/A,QA H2,QA H2/A,QAP2/A,QA2/A,QA26/A
			1	-	-		QE/A,QH/A,QHB3/A,QHB5,QHE/A,QHP1/A,QHQ4/A,QL2,QME0/A,QMH/A,QMT2/A
			1	-	-		QMX2,QNE2/A,QNR2/A,QNR6/A,QTC2/A,QX/A,QXB/A,QXB7,QXB7/A,QXE/A
			1	-	-		QXE4/A,QXE6/A,QXE8/A,QXQ4/A,QXU/A,SE/A,SH/A,SHB3/A,SHQ4/A,SJ/A
			1	-	-		SJG/A,SKE/A,SKZ/A,SMEO/A,SMX2/A,STP/A,STQ/A,STR/A,SX/A,SXB/A,SXB7
			1	-	-		SXB7/A,SXE/A,SXEB/A,SXE4/A,SXE8/A,SXQ4/A,SXU/A,VWC2/A,VWS2/A
			1	-	-		VX16/A
			1	-	-	2519696	HA2,HX2,HX26,LXE2,LXE6,LX2,LX26,PKT2,QAE2,QAE6,QAP2,QA2,QA26,QH2
			1	-	-	2701602	QMT2,QNE2,QNE6,QNR2,QNR6,QPE2,QTC2,QXE2,QXE6,QX2,SME2,SMX2,SXE2
			1	-	-	3032024	VD16,VEB6,VX16
			1	-	-		LH,LHB3,LHE,LHQ4,LJ,LJG,LKE,LX,LXE,LXE4,LXE8,LXQ4,LXU,PX,QE,QH
			1	-	-		QHB3,QHE,QHP1,QHQ4,QME0,QMH,QN18,QX,QXE,QXE4,QXE8,QXQ4,QXU,SDE,SE
			1	-	-		SH,SHB1,SHB3,SHE,SHQ4,SJ,SJG,SKE,SKZ,SMEO,STP,STQ,STR,SX,SXE,SXE4
			1	-	-		SXE8,SXQ4,SXU
			1	-	-	3129574	PKX4
			1	-	-	2519696	2588534
			1	-	-	3852704	VAD2,VA2,VDE2,VH12,VH22,VWA2,VWC2,VWE2,VWS2,VW12,VXB2,VXE2,VXE6
	16100-ZE3-W12	CARBURETOR ASSY. (BE47A C) ..	1	-	-		QXC4/A
			-	(1)	-		Q1/A,S1/A
	16100-ZE3-W32	CARBURETOR ASSY. (BE34B D) ..	1	(1)	-	3852704	LT/A,L1/A,PXE8/A,P1/A,QKA4/A,QME8/A,QP/A,QT/A,Q1/A,STJ/A,SWX/A
							S1/A

Ref. No.	Part No.	Description	Reqd. QTY			Serial No.	Parts catalogue code
			(1)	(2)	(3)		
11)	16100-ZE3-D52	CARBURETOR ASSY. (BE34C C) ..	1	-	-	-----	EDK
			1	-	-	3858558	ED9/A
	16100-ZE3-F31	CARBURETOR ASSY. (BE80D B/C)	1	-	-	-----	EDN5/A, ED8/A, ES1/A, ES2, VAD2/A, VA2/A, VDE2/A, VH12/A, VH22/A, VSH7 VWE2/A, VW12/A, VX/A, VXB/A, VXB7, VXB7/A, VXE/A, VXEB/A, VXE2/A, VXE7 VXE7/A, VXE8/A, VXX, VXQ4/A, VXU/A, VXU1/A, VX8/A
			1	-	-	2588535	VAD2, VA2, VDE2, VH12, VH22, VWA2, VWE2, VW12, VXB2, VXE2, VXE6
			1	-	-	3032024	EDN5, ED7, ED8, ES1, VH, VMX, VX, VXB, VXE, VXEB, VXE4, VXE8, VXQ4, VXU, VXU1 VX8
			1	-	-	2588535	VWC2, VWS2
			1	-	-	3032024	3211411 QXB, SXB, SXEB
	16100-ZE3-V01	CARBURETOR ASSY. (BE80B B) ..	1	-	-	3030650	VWC2, VWS2
			1	-	-	3211412	QXB, SXB, SXEB
	16100-ZE3-V20	CARBURETOR ASSY. (BE80C A) ..	1	-	-	2526725	QDW9, QXC6, QXC9
	16100-ZE3-V21	CARBURETOR ASSY. (BE80C B) ..	1	-	-	-----	QDW9/A, QWH2, QWH2/A, QXC/A, QXC6/A, QXC9/A
			1	-	-	2526726	QDW9, QXC6, QXC9
			1	-	-	3032024	QXC
	16100-ZH9-W30	CARBURETOR ASSY. (BE21C A) ..	1	-	-	2521899	LP
	16100-ZH9-W31	CARBURETOR ASSY. (BE21C B) ..	1	-	-	2521900	LP
13	16124-ZE0-005	SCREW, THROTTLE STOP .....	1	-	-	-----	BJ, EDK, EDN5, EDN5/A, ED7, ED8, ED8/A, ED9, ED9/A, EN, ES, ES1, ES1/A, ES2, ET ETS, ETX, HA, HAQ, HA2, HA2/A, HH, HX, HX2, HX26, HX26/A, LH, LH/A, LHB1, LHB3 LHB3/A, LHB5, LHC, LHE, LHE/A, LHQ4, LHQ4/A, LHW, LJ, LJ/A, LJG, LJG/A, LJS LJS/A, LJS1, LKE, LKE/A, LP, LSX, LT, LT/A, LWD, LX, LX/A, LXE, LXE/A, LXE2 LXE2/A, LXE4, LXE4/A, LXE6, LXE8, LXE8/A, LXQ4, LXQ4/A, LXU, LXU/A, LXZ, LXZ LX2/A, LX26, LX26/A, PKT2, PKT2/A, PKT4, PKT4/A, PKX2, PKX4, PKX4/A, PX PX/A, PXA2, PXE8, PXE8/A, QA, QAB2, QAB2/A, QAC2, QAC2/A, QAE, QAE2, QAE2/A QAE6, QAE6/A, QAG, QAG/A, QAH2, QAH2/A, QAP, QAPE, QAP2, QAP2/A, QAQ, QA2 QA2/A, QA26, QA26/A, QDW9, QDW9/A, QE, QE/A, QH, QH/A, QHB3, QHB3/A, QHB5 QHC, QHE, QHE/A, QHP1, QHP1/A, QHQ4, QHQ4/A, QH2, QKA4, QKA4/A, QL2, QMEO QMEO/A, QME8, QME8/A, QMH, QMH/A, QMT2, QMT2/A, QMX2, QNE, QNE2, QNE2/A QNE6, QNE9, QNE9/A, QNR2, QNR2/A, QNR6, QNR6/A, QN18, QP, QP/A, QPE2, QT QT/A, QTC2, QTC2/A, QWH2, QWH2/A, QX, QX/A, QXB, QXB/A, QXB7, QXB7/A, QXC QXC/A, QXC4, QXC4/A, QXC6, QXC6/A, QXC9, QXC9/A, QXE, QXE/A, QXEB, QXE2 QXE4, QXE4/A, QXE6, QXE6/A, QXE8, QXE8/A, QXQ4, QXQ4/A, QXU, QXU/A, QX2, SDE SE, SE/A, SH, SH/A, SHB1, SHB3, SHB3/A, SHE, SHEZ, SHQ4, SHQ4/A, SHT, SJ, SJ/A SJG, SJG/A, SKE, SKE/A, SKZ, SKZ/A, SMEO, SMEO/A, SME2, SMX2, SMX2/A, STJ STJ/A, STP, STP/A, STQ, STQ/A, STR, STR/A, SWX, SWX/A, SX, SX/A, SXB, SXB/A SXB7, SXB7/A, SXE, SXE/A, SXEB, SXEB/A, SXE2, SXE4, SXE4/A, SXE8, SXE8/A SXP, SXQ4, SXQ4/A, SXU, SXU/A, VA, VAA, VAAE, VAD2, VAD2/A, VAH1, VAH2, VAW1 VA2, VA2/A, VDE, VDE2, VDE2/A, VD16, VE, VEB6, VH, VHE, VH12, VH12/A, VH22 VH22/A, VMX, VNG, VNG1, VNG2, VSH7, VWA, VWA2, VWC2, VWC2/A, VWE2, VWE2/A VWS2, VWS2/A, VW12, VW12/A, VX, VX/A, VXA, VXB, VXB/A, VXB2, VXB7, VXB7/A VXE, VXE/A, VXEB, VXEB/A, VXE2, VXE2/A, VXE4, VXE6, VXE7, VXE7/A, VXE8 VXE8/A, VXG, VXX, VXQ4, VXQ4/A, VXU, VXU/A, VXU1, VXU1/A, VX16, VX16/A, VX8 VX8/A, YJ
			-	(1)	-	-----	
			1	-	-	-----	LHC, QHC, QXC4, QXC4/A, SHT
			1	-	-	-----	BE47A B QXC
			-	(1)	-	-----	
14	16166-ZE3-W10	NOZZLE, MAIN .....					
		(CARBURETOR NO.)					



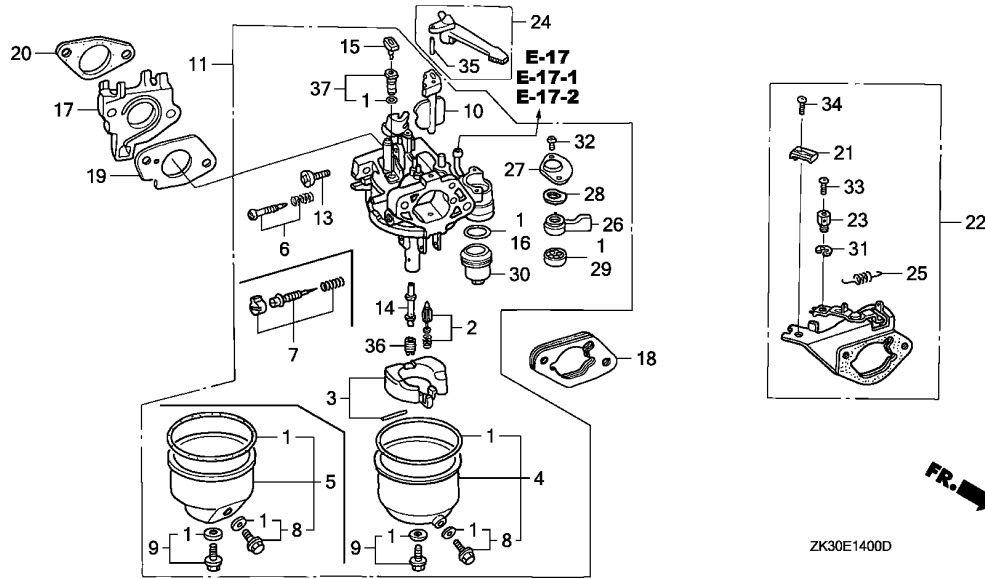

2

Ref. No.	Part No.	Description	Reqd. QTY			Serial No.	Parts catalogue code
			GX	340K1			
			(1)	(2)	(3)		
14)	16166-ZE3-W20	NOZZLE, MAIN .....	1	-	-	-----	BJ,EDK,ED9,ED9/A,EN,ES,ET,ETS,ETX,HA,HH,HX,LHB1,LHW,LSX,LT,LT/A,LXZ,PXE8,PXE8/A,QA,QAE,QAP,QAPE,QKA4,QKA4/A,QME8,QME8/A,QNE,QP,QP/A,QT,QT/A,QXEB,SHEZ,STJ,STJ/A,SWX,SWX/A,SXP,VA,VAA,VAAE,VAH1,VAH2,VAW1,VDE,VE,VHE,VNG,VNG1,VNG2,VWA,VXA,VXG,YJ
		(CARBURETOR NO.)	1	-	-	-----	BE34B C LH,LHB3,LHE,LHQ4,LJ,LJG,LKE,LX,LXE,LXE4,LXE8,LXQ4,LXU,PKX4,PX,QE,QH,QHB3,QHE,QHP1,QHQ4,QMEO,QMH,QN18,QX,QXB,QXE,QXE4,QXE8,QXQ4,QXSDE,SE,SH,SHB1,SHB3,SHE,SHQ4,SJ,SJG,SKE,SKZ,SMEO,STP,STQ,STR,SXSXB,SXE,SXEB,SXE4,SXE8,SXQ4,SXU
		//	1	-	-	-----	BE34C B EDN5,ED7,ED8,ES1,VD16,VEB6,VH,VMX,VX,VXB,VXE,VXEB,VXE4,VXE8,VXQ4,VXU,VXU1,VX16,VX8
			-	(1)	-		





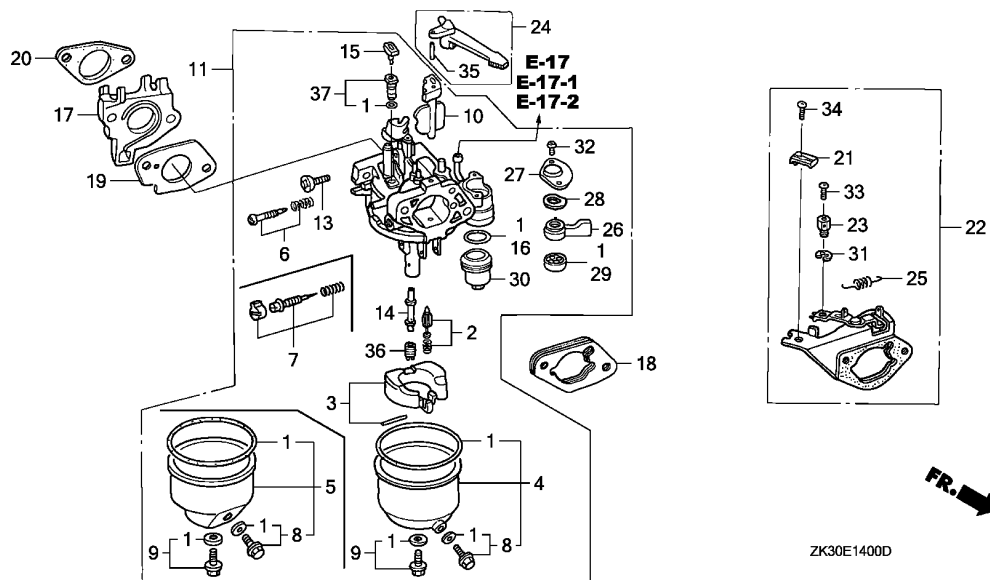

2

Ref. No.	Part No.	Description	Reqd. QTY			Serial No.	Parts catalogue code
			GX	340K1	(3)		
16	16173-001-004	PACKING, FUEL STRAINER CUP ..	1	-	-	-----	BJ,EDK,EDN5,EDN5/A,ED7,ED8,ED8/A,ED9,ED9/A,EN,ES,ES1,ES1/A,ES2,ETS,ETX,HA,HAQ,HA2,HA2/A,HH,HX,HX2,HX26,HX26/A,LH,LH/A,LHB1,LHB3,LHB3/A,LHB5,LHC,LHE,LHE/A,LHQ4,LHQ4/A,LHW,LJ,LJ/A,LJG,LJG/A,LJS,LJS/A,LJS1,LKE,LKE/A,LP,LSX,LT,LT/A,LWD,LX,LX/A,LXE,LXE/A,LXE2,LXE2/A,LXE4,LXE4/A,LXE6,LXE8,LXE8/A,LXQ4,LXQ4/A,LXU,LXU/A,LXZ,LX2,LX2/A,LX26,LX26/A,PKT2,PKT2/A,PKT4,PKT4/A,PKX2,PKX4,PKX4/A,PX,PX/A,PXA2,PXE8,PXE8/A,QA,QAB2,QAB2/A,QAC2,QAC2/A,QAE,QAE2,QAE2/A,QAE6,QAE6/A,QAG,QAG/A,QA2,QA2/A,QAH2,QAH2/A,QAP,QAPE,QAPE2,QAPE2/A,QAQ,QA2,QA2/A,QA26,QA26/A,QDW9,QDW9/A,QE,QE/A,QH,QH/A,QHB3,QHB3/A,QHB5,QHC,QHE,QHE/A,QHP1,QHP1/A,QHQ4,QHQ4/A,QH2,QKA4,QKA4/A,QL2,QMEO,QMEO/A,QME8,QME8/A,QMH,QMH/A,QMT2,QMT2/A,QMX2,QNE,QNE2,QNE2/A,QNE6,QNE9,QNE9/A,QNR2,QNR2/A,QNR6,QNR6/A,QN18,QP,QP/A,QPE2,QT,QT/A,QTC2,QTC2/A,QWH2,QWH2/A,QX,QX/A,QXB,QXB/A,QXB7,QXB7/A,QXC,QXC/A,QXC4,QXC4/A,QXC6,QXC6/A,QXC9,QXC9/A,QXE,QXE/A,QXEB,QXE2,QXE4,QXE4/A,QXE6,QXE6/A,QXE8,QXE8/A,QXQ4,QXQ4/A,QXU,QXU/A,QX2,SDE,SE,SE/A,SH,SH/A,SHB1,SHB3,SHB3/A,SHE,SHEZ,SHQ4,SHQ4/A,SHT,SJ,SJ/A,SJG,SJG/A,SKE,SKE/A,SKZ,SKZ/A,SMEO,SMEO/A,SMX2,SMX2/A,STJ,STJ/A,STP,STP/A,STQ,STQ/A,STR,STR/A,SWX,SWX/A,SX,SX/A,SXB,SXB/A,SXB7,SXB7/A,SXE,SXE/A,SXEB,SXEB/A,SXE2,SXE4,SXE4/A,SXE8,SXE8/A,SXP,SXQ4,SXQ4/A,SXU,SXU/A,VA,VAA,VAAE,VAD2,VAD2/A,VAH1,VAH2,VAW1,VA2,VA2/A,VDE,VDE2,VDE2/A,VD16,VE,VEB6,VH,VHE,VH12,VH12/A,VH22,VH22/A,VMX,VNG,VNG1,VNG2,VSH7,VVA,VVA2,VWC2,VWC2/A,VWE2,VWE2/A,VWS2,VWS2/A,VW12,VW12/A,VX,VX/A,VXA,VXB,VXB/A,VXB2,VXB7/VXB7/A,VXE,VXE/A,VXEB,VXEB/A,VXE2,VXE2/A,VXE4,VXE6,VXE7,VXE7/A,VXE8,VXE8/A,VXG,VXK,VXQ4,VXQ4/A,VXU,VXU/A,VXU1,VXU1/A,VX16,VX16/A,VX8,VX8/A,YJ
17	16211-ZE2-000	INSULATOR, CARBURETOR .....	1	-	-	-----	LP

Ref. No.	Part No.	Description	Reqd. QTY			Serial No.	Parts catalogue code
			(1)	(2)	(3)		
17)	16211-ZF6-000	INSULATOR, CARBURETOR .....	1	-	-	-----	BJ,EDK,ED9,ED9/A,EN,ES,ET,ETS,ETX,HA,HH,HX,LHB1,LHC,LHW,LSX,LT LT/A,LXZ,PXE8,PXE8/A,QA,QAE,QAP,QAPE,QHC,QKA4,QKA4/A,QME8,QME8/A QNE,QP,QP/A,QT,QT/A,QXC4,QXC4/A,QXEB,SHEZ,SHT,STJ,STJ/A,SWX,SWX/A SXP,VA,VAA,VAAE,VAH1,VAH2,VAW1,VDE,VE,VHE,VNG,VNG1,VNG2,VWA,VXA VXG,YJ
			1	-	-	-----	2701601 VD16,VEB6,VX16
			1	-	-	-----	3032023 EDN5,ED7,ED8,ES1,LH,LHB3,LHE,LHQ4,LJ,LJG,LKE,LX,LXE,LXE4,LXE8 LXQ4,LXU,PX,QE,QH,QHB3,QHE,QHP1,QHQ4,QMEO,QMH,QN18,QX,QXB,QXC,QXE QXE4,QXE8,QXQ4,QXU,SDE,SE,SH,SHB1,SHB3,SHE,SHQ4,SJ,SJG,SKE,SKZ SMEO,STP,STQ,STR,SX,SXB,SXE,SXEB,SXE4,SXE8, SXQ4,SXU,VH,VMX,VX,VXB VXE,VXEB,VXE4,VXE8,VXQ4,VXU,VXU1,VX8
			1	-	-	-----	3129573 PKX4
	16211-ZE3-000	.....	1	-	-	-----	EDN5/A,ED8/A,ES1/A,ES2,HAQ,HA2,HA2/A,HX2,HX26,HX26/A,LH/A,LHB3/A LHB5,LHE/A,LHQ4/A,LJ/A,LJG/A,LJS,LJS/A,LJS1,LKE/A,LWD,LX/A,LXE/A LXE2,LXE2/A,LXE4/A,LXE6,LXE8/A,LXQ4/A,LXU/A,LX2,LX2/A,LX26,LX26/A PKT2,PKT2/A,PKT4,PKT4/A,PKX2,PKX4/A,PX/A,PXA2,QAB2,QAB2/A,QAC2 QAC2/A,QAE2,QAE2/A,QAE6,QAE6/A,QAG,QAG/A,QA2,QA2/A,QAP2,QAP2/A QAQ,QA2,QA2/A,QA26,QA26/A,QDW9,QDW9/A,QE/A,QH/A,QHB3/A,QHB5,QHE/A QHP1/A,QHQ4/A,QH2,QL2,QMEO/A,QMH/A,QMT2,QMT2/A,QMX2,QNE2,QNE2/A QNE6,QNE9,QNE9/A,QNR2,QNR2/A,QNR6,QNR6/A,QPE2,QTC2,QTC2/A,QWH2 QWH2/A,QX/A,QXB/A,QXB7,QXB7/A,QXC/A,QXC6,QXC6/A,QXC9,QXC9/A,QXE/A QXE2,QXE4/A,QXE6,QXE6/A,QXE8/A,QXQ4/A,QXU/A,QX2,SE/A,SH/A,SHB3/A SHQ4/A,SJ/A,SJG/A,SKE/A,SKZ/A,SMEO/A,SME2,SMX2,SMX2/A,STP/A,STQ/A STR/A,SX/A,SXB/A,SXB7,SXB7/A,SXE/A,SXEB/A,SXE2,SXE4/A,SXE8/A SXQ4/A,SXU/A,VAD2,VAD2/A,VA2,VA2/A,VDE2,VDE2/A,VH12,VH12/A,VH22 VH22/A,VSH7,VWA2,VWC2,VWC2/A,VWE2,VWE2/A,VWS2,VWS2/A,VW12,VW12/A VX/A,VXB/A,VXB2,VXB7,VXB7/A,VXE/A,VXEB/A,VXE2,VXE2/A,VXE6,VXE7 VXE7/A,VXE8/A,VXK,VXQ4/A,VXU/A,VXU1/A,VX16/A,VX8/A
			1	-	-	-----	2701602 VD16,VEB6,VX16
			1	-	-	-----	3032024 EDN5,ED7,ED8,ES1,LH,LHB3,LHE,LHQ4,LJ,LJG,LKE,LX,LXE,LXE4,LXE8 LXQ4,LXU,PX,QE,QH,QHB3,QHE,QHP1,QHQ4,QMEO,QMH,QN18,QX,QXB,QXC,QXE QXE4,QXE8,QXQ4,QXU,SDE,SE,SH,SHB1,SHB3,SHE,SHQ4,SJ,SJG,SKE,SKZ SMEO,STP,STQ,STR,SX,SXB,SXE,SXEB,SXE4,SXE8, SXQ4,SXU,VH,VMX,VX,VXB VXE,VXEB,VXE4,VXE8,VXQ4,VXU,VXU1,VX8
			1	-	-	-----	3129574 PKX4



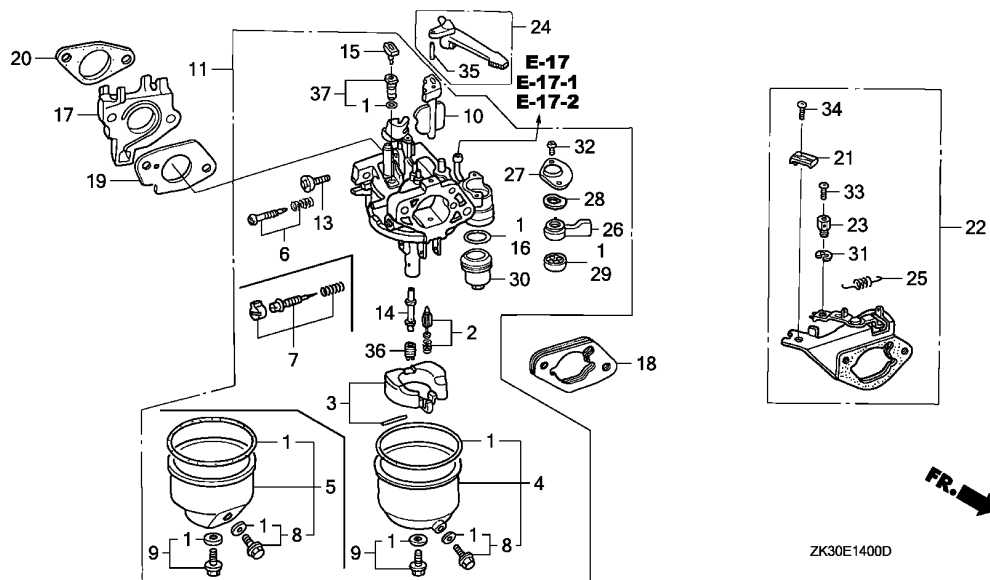

2

Ref. No.	Part No.	Description	Reqd. QTY			Serial No.	Parts catalogue code
			GX	340K1	(3)		
18	16220-ZA0-702	SPACER COMP., CARBURETOR	1	-	-	-----	BJ,EDK,EDN5,EDN5/A,ED7,ED8,ED8/A,ED9,ED9/A,EN,ES,ES1,ES1/A,ES2,ETS,ETX,HA,HAQ,HA2,HA2/A,HH,HX,HX2,HX26,HX26/A,LH,LH/A,LHB1,LHB3,LHB3/A,LHB5,LHC,LHE,LHE/A,LHQ4,LHQ4/A,LHW,LJ,LJ/A,LJG,LJG/A,LJS,LJS/A,LJS1,LSX,LT,LT/A,LX,LX/A,LXE,LXE/A,LXE2,LXE2/A,LXE4,LXE4/A,LXE6,LXE8,LXE8/A,LXQ4,LXQ4/A,LXU,LXU/A,LXZ,LX2,LX2/A,LX26,LX26/A,PKT2,PKT2/A,PKT4,PKT4/A,PKX2,PKX4,PKX4/A,PX,PX/A,PXA2,PXE8,PXE8/A,QA,QAB2,QAB2/A,QAC2,QAC2/A,QAE,QAE2,QAE2/A,QAE6,QAE6/A,QAG,QAG/A,QAH2,QAH2/A,QAP,QAPE,QAP2,QAP2/A,QAQ,QA2,QA2/A,QA26,QA26/A,QDW9,QDW9/A,QE,QE/A,QH,QH/A,QHB3,QHB3/A,QHB5,QHC,QHE,QHE/A,QHP1,QHP1/A,QHQ4,QHQ4/A,QH2,QKA4,QKA4/A,QL2,QMED,QMED/A,QME8,QME8/A,QMH,QMH/A,QMT2,QMT2/A,QMX2,QNE,QNE2,QNE2/A,QNE6,QNE9,QNE9/A,QNR2,QNR2/A,QNR6,QNR6/A,QN18,QP,QP/A,QPE2,QT,QT/A,QTC2,QTC2/A,QWH2,QWH2/A,QX,QX/A,QXB,QXB/A,QXB7,QXB7/A,QXC,QXC/A,QXC4,QXC4/A,QXC6,QXC6/A,QXC9,QXC9/A,QXE,QXE/A,QXEB,QXE2,QXE4,QXE4/A,QXE6,QXE6/A,QXE8,QXE8/A,QXQ4,QXQ4/A,QXU,QXU/A,QX2,SE,SE/A,SH,SH/A,SHB1,SHB3,SHB3/A,SHE,SHEZ,SHQ4,SHQ4/A,SHT,SJ,SJ/A,SJG,SJG/A,SKE,SKE/A,SKZ,SKZ/A,SMED,SMED/A,SME2,SMX2,SMX2/A,STP,STP/A,STQ,STQ/A,STR,STR/A,SWX,SWX/A,SX,SX/A,SXB,SXB/A,SXB7,SXB7/A,SXE,SXE/A,SXEB,SXEB/A,SXE2,SXE4,SXE4/A,SXE8,SXE8/A,SXP,SXQ4,SXQ4/A,SXU,SXU/A,VA,VAA,VAE,VAD2,VAD2/A,VAH1,VAH2,VAW1,VA2,VA2/A,VDE,VDE2,VDE2/A,VD16,VE,VEB6,VH,VHE,VH12,VH12/A,VH22,VH22/A,VMX,VNG,VNG1,VNG2,VSH7,VVA,VVA2,VWC2,VWC2/A,VWE2,VWE2/A,VWS2,VWS2/A,VW12,VW12/A,VX,VX/A,VXA,VXB,VXB/A,VXB2,VXB7,VXB7/A,VXE,VXE/A,VXEB,VXEB/A,VXE2,VXE2/A,VXE4,VXE6,VXE7,VXE7/A,VXE8,VXE8/A,VXG,VXK,VXQ4,VXQ4/A,VXU,VXU/A,VXU1,VXU1/A,VX16,VX16/A,VX8,VX8/A,YJ
19	16221-ZA0-700 16221-ZA0-800	PACKING, CARBURETOR	1	-	-	-----	2188577 LP ----- LP

Ref. No.	Part No.	Description	Reqd. QTY			Serial No.	Parts catalogue code	
			(1)	(2)	(3)			
19)	16221-ZE3-800	PACKING, CARBURETOR .....	1	-	-	-----	EDN5/A,ED8/A,ES1/A,ES2,HAQ,HA2,HA2/A,HX2,HX26,HX26/A,LH/A,LHB3/A,LHB5,LHE/A,LHQ4/A,LJ/A,LJG,LJG/A,LJS,LJS/A,LJS1,LKE/A,LWD,LX/A,LXE/A,LXE2,LXE2/A,LXE4/A,LXE6,LXE8/A,LXQ4/A,LXU/A,LX2,LX2/A,LX26/LX26/A,PKT2,PKT2/A,PKT4,PKT4/A,PKX2,PKX4/A,PX/A,PXA2,QAB2,QAB2/A,QAC2,QAC2/A,QAE2,QAE2/A,QAE6,QAE6/A,QAG,QAG/A,QA2,QA2/A,QAP2,QAP2/A,QAQ,QA2,QA2/A,QA26,QA26/A,QDW9,QDW9/A,QE/A,QH/A,QHB3/A,QHB5,QHE/A,QHP1/A,QHQ4/A,QH2,QL2,QMEO/A,QMH/A,QMT2,QMT2/A,QMX2,QNE2,QNE2/A,QNE6,QNE9,QNE9/A,QNR2,QNR2/A,QNR6,QNR6/A,QPE2,QTC2,QTC2/A,QWH2,QWH2/A,QX/A,QXB/A,QXB7,QXB7/A,QXC/A,QXC6,QXC6/A,QXC9,QXC9/A,QXE/A,QXE2,QXE4/A,QXE6,QXE6/A,QXE8/A,QXQ4/A,QXU/A,QX2,SE/A,SH/A,SHB3/A,SHQ4/A,SJ/A,SJG,SJG/A,SKE/A,SKZ/A,SMEO/A,SME2,SMX2,SMX2/A,STP,STP/A,STQ,STQ/A,STR,STR/A,SX/A,SXB/A,SXB7,SXB7/A,SXE/A,SXE2,SXE4/A,SXE8/A,SXQ4/A,SXU/A,VAD2,VAD2/A,VA2,VA2/A,VDE2,VDE2/A,VH12,VH12/A,VH22,VH22/A,VSH7,VWA2,VWC2,VWC2/A,VWE2,VWE2/A,VWS2,VWS2/A,VW12,VW12/A,VX/A,VXB/A,VXB2,VXB7,VXB7/A,VXE/A,VXEB/A,VXE2,VXE2/A,VXE6,VXE7,VXE7/A,VXE8/A,VXK,VXQ4/A,VXU/A,VXU1/A,VX16/A,VX8/A	
			1	-	-	2701602	-----	VD16,VEB6,VX16
			1	-	-	3032024	-----	EDN5,ED7,ED8,ES1,LH,LHB3,LHE,LHQ4,LJ,LKE,LX,LXE,LXE4,LXE8,LXQ4,LXU,PX,QE,QH,QHB3,QHE,QHP1,QHQ4,QMEO,QMH,QN18,QX,QXB,QXC,QXE,QXE4,QXE8,QXQ4,QXU,SE,SH,SHB1,SHB3,SHE,SHQ4,SJ,SKE,SKZ,SMEO,SX,SXB,SXE,SXEB,SXE4,SXE8,SXQ4,SXU,VH,VMX,VX,VXB,VXE,VXEB,VXE4,VXE8,VXQ4,VXU1,VX8
			1	-	-	3129574	-----	PKX4
	16221-ZF6-000	.....	1	(1)	-	2178372	-----	BJ,EN,ET,ETS,ETX,LJ,LXZ,L1,P1,QT,Q1,SHEZ,SJ,STJ,SWX,S1,V1,YJ
	16221-ZF6-800	.....	1	(1)	-	-----	-----	EDK,ED9,ED9/A,ES,HA,HH,HX,LHB1,LHC,LHW,LSX,LT,LT/A,L1/A,PXE8,PXE8/A,P1/A,QA,QAE,QAP,QAPE,QHC,QKA4,QKA4/A,QME8,QME8/A,QNE,QP,QP/A,QT/A,QXC4,QXC4/A,QXEB,Q1/A,SDE,SHT,STJ/A,SWX/A,SXP,S1/A,VA,VAA,VAE,VAH1,VAH2,VAW1,VDE,VE,VHE,VNG,VNG1,VNG2,VWA,VXA,VXG
			1	(1)	-	2178373	-----	BJ,EN,ET,ETS,ETX,LXZ,L1,P1,QT,Q1,SHEZ,STJ,SWX,S1,V1,YJ
			1	-	-	2701601	-----	VD16,VEB6,VX16
			1	-	-	3032023	-----	EDN5,ED7,ED8,ES1,LH,LHB3,LHE,LHQ4,LKE,LX,LXE,LXE4,LXE8,LXQ4,LXU,PX,QE,QH,QHB3,QHE,QHP1,QHQ4,QMEO,QMH,QN18,QX,QXB,QXC,QXE,QXE4,QXE8,QXQ4,QXU,SE,SH,SHB1,SHB3,SHE,SHQ4,SKE,SKZ,SMEO,SX,SXB,SXE,SXEB,SXE4,SXE8,SXQ4,SXU,VH,VMX,VX,VXB,VXE,VXEB,VXE4,VXE8,VXQ4,VXU1,VX8
			1	-	-	3129573	-----	PKX4
			1	-	-	2178373	-----	3032023 LJ,SJ
			1	-	-	2188577	-----	LP
			1	-	-	2188578	-----	LP
	16223-ZA0-700	PACKING, INSULATOR .....	1	(1)	-	2178372	-----	BJ,EN,ET,ETS,ETX,LJ,LXZ,L1,P1,QT,Q1,SHEZ,SJ,STJ,SWX,S1,V1,YJ
	16223-ZA0-800	.....	1	(1)	-	-----	-----	EDK,ED9,ED9/A,ES,HA,HH,HX,LHB1,LHC,LHW,LSX,LT,LT/A,L1/A,PXE8,PXE8/A,P1/A,QA,QAE,QAP,QAPE,QHC,QKA4,QKA4/A,QME8,QME8/A,QNE,QP,QP/A,QT/A,QXC4,QXC4/A,QXEB,Q1/A,SHT,STJ/A,SWX/A,SXP,S1/A,VA,VAA,VAE,VAH1,VAH2,VAW1,VDE,VE,VHE,VNG,VNG1,VNG2,VWA,VXA,VXG
	16223-ZF6-000	.....	1	(1)	-	2178373	-----	BJ,EN,ET,ETS,ETX,LXZ,L1,P1,QT,Q1,SHEZ,STJ,SWX,S1,V1,YJ
	16223-ZE3-800	.....	1	(1)	-	3032023	-----	EDN5,ED7,ED8,ES1,LH,LHB3,LHE,LHQ4,LJG,LKE,LX,LXE,LXE4,LXE8,LXQ4,LXU,PX,QE,QH,QHB3,QHE,QHP1,QHQ4,QMEO,QMH,QN18,QX,QXB,QXC,QXE,QXE4,QXE8,QXQ4,QXU,SDE,SE,SH,SHB1,SHB3,SHE,SHQ4,SJG,SKE,SKZ,SMEO,STP,STQ,STR,SX,SXB,SXE,SXEB,SXE4,SXE8,SXQ4,SXU,VH,VMX,VX,VXB,VXE,VXEB,VXE4,VXE8,VXQ4,VXU1,VX8
			1	-	-	3129573	-----	PKX4
			1	-	-	2178373	-----	3032023 LJ,SJ

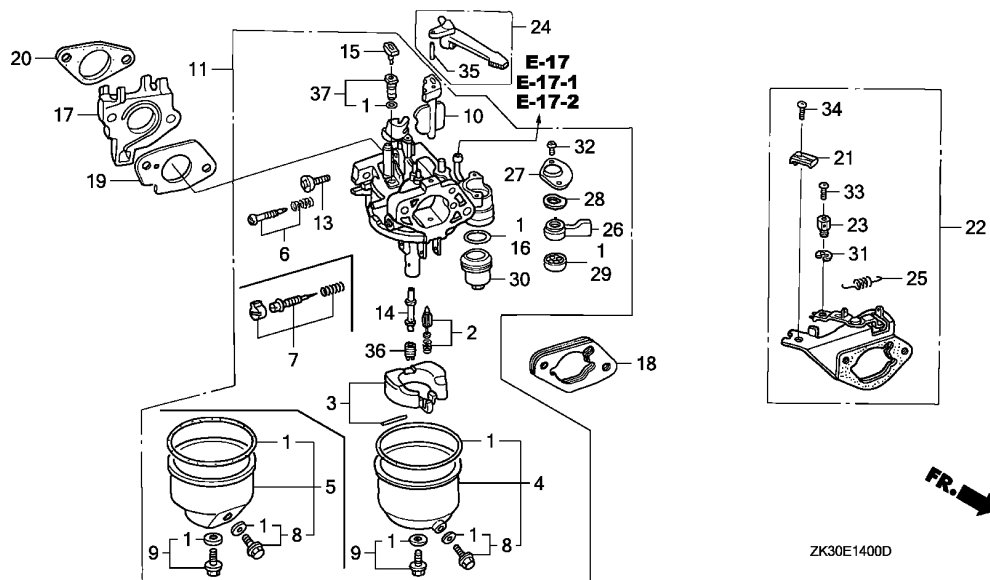

2

Ref. No.	Part No.	Description	Reqd. QTY			Serial No.	Parts catalogue code	
			GX	340K1	(3)			
20)	16223-ZE3-800	PACKING, INSULATOR .....	1	-	-	-----	EDN5/A,ED8/A,ES1/A,ES2,HAQ,HA2,HA2/A,HX2,HX26,HX26/A,LH/A,LHB3/A,LHB5,LHE/A,LHQ4/A,LJ/A,LJG/A,LJS,LJS/A,LJS1,LKE/A,LWD,LX/A,LXE/A,LXE2,LXE2/A,LXE4/A,LXE6,LXE8/A,LXQ4/A,LXU/A,LX2,LX2/A,LX26,LX26/A,PKT2,PKT2/A,PKT4,PKT4/A,PKX2,PKX4/A,PX/A,PXA2,QAB2,QAB2/A,QAC2,QAC2/A,QAE2,QAE2/A,QAE6,QAE6/A,QAG,QAG/A,QA2,QA2/A,QAP2,QAP2/A,QAQ,QA2,QA2/A,QA26,QA26/A,QDW9,QDW9/A,QE/A,QH/A,QHB3/A,QHB5,QHE/A,QHP1/A,QHQ4/A,QH2,QL2,QME0/A,QMH/A,QMT2,QMT2/A,QMX2,QNE2,QNE2/A,QNE6,QNE9,QNE9/A,QNR2,QNR2/A,QNR6,QNR6/A,QPE2,QTC2,QTC2/A,QWH2,QWH2/A,QX/A,QXB/A,QXB7,QXB7/A,QXC/A,QXC6,QXC6/A,QXC9,QXC9/A,QXE/A,QXE2,QXE4/A,QXE6,QXE6/A,QXE8/A,QXQ4/A,QXU/A,QX2,SE/A,SH/A,SHB3/A,SHQ4/A,SJ/A,SJG/A,SKE/A,SKZ/A,SMEO/A,SME2,SMX2,SMX2/A,STP/A,STQ/A,STR/A,SX/A,SXB/A,SXB7,SXB7/A,SXE/A,SXEB/A,SXE2,SXE4/A,SXE8/A,SXQ4/A,SXU/A,VAD2,VAD2/A,VA2,VA2/A,VDE2,VDE2/A,VD16,VEB6,VH12,VH12/A,VH22,VH22/A,VSH7,VWA2,VWC2,VWC2/A,VWE2,VWE2/A,VWS2,VWS2/A,VW12,VW12/A,VX/A,VXB/A,VXB2,VXB7,VXB7/A,VXE/A,VXEB/A,VXE2,VXE2/A,VXE6,VXE7,VXE7/A,VXE8/A,VXK,VXQ4/A,VXU/A,VXU1/A,VX16,VX16/A,VX8/A	
			1	-	-	3032024	-----	EDN5,ED7,ED8,ES1,LH,LHB3,LHE,LHQ4,LJ,LJG,LKE,LX,LXE,LXE4,LXE8,LXQ4,LXU,PX,QE,QH,QHB3,QHE,QHP1,QHQ4,QME0,QMH,QN18,QX,QXB,QXC,QXE,QXE4,QXE8,QXQ4,QXU,SDE,SE,SH,SHB1,SHB3,SHE,SHQ4,SJ,SJG,SKE,SKZ,SMEO,STP,STQ,STR,SX,SXB,SXE,SXEB,SXE4,SXE8,SXQ4,SXU,VH,VMX,VX,VXB,VXE,VXEB,VXE4,VXE8,VXQ4,VXU,VXU1,VX8
			1	-	-	3129574	-----	PKX4
21	16576-891-000	HOLDER, CABLE .....	1	-	-	-----	LKE,LKE/A,LWD,SDE,STJ,STJ/A	
			-	(1)	-	-----		
22	16590-ZE2-812	STAY ASSY., CHOKE CONTROL (REMOTE)	1	-	-	-----	LKE,LKE/A,LWD,SDE,STJ,STJ/A	
			-	(1)	-	-----		

Ref. No.	Part No.	Description	Reqd. QTY			Serial No.	Parts catalogue code
			(1)	(2)	(3)		
23	16594-883-010	HOLDER, WIRE .....	1	-	-	LKE,LKE/A,LWD,SDE,STJ,STJ/A	
			-	(1)	-		
24	16610-ZE1-000	LEVER COMP., CHOKE (STD.) ...	1	-	-	BJ,EDK,EDN5,EDN5/A,ED7,ED8,ED8/A,ED9,ED9/A,EN,ES,ES1,ES1/A,ES2,ETS,ETX,HA,HAQ,HA2,HA2/A,HH,HX,HX2,HX26,HX26/A,LH,LH/A,LHB1,LHB3,LHB3/A,LHB5,LHC,LHE,LHE/A,LHQ4,LHQ4/A,LHW,LJ,LJ/A,LJG,LJG/A,LJS,LJS/A,LJS1,LP,LSX,LT,LT/A,LX,LX/A,LXE,LXE/A,LXE2,LXE2/A,LXE4,LXE4/A,LXE6,LXE8,LXE8/A,LXQ4,LXQ4/A,LXU,LXU/A,LXZ,LX2,LX2/A,LX26,LX26/A,PKT2,PKT2/A,PKT4,PKT4/A,PKX2,PKX4,PKX4/A,PX,PX/A,PXA2,PXE8,PXE8/A,QA,QAB2,QAB2/A,QAC2,QAC2/A,QAE,QAE2,QAE2/A,QAE6,QAE6/A,QAG,QAG/A,QAQ2,QAQ2/A,QAP,QAPE,QAP2,QAP2/A,QAQ,QA2,QA2/A,QA26,QA26/A,QDW9,QDW9/A,QE,QE/A,QH,QH/A,QHB3,QHB3/A,QHB5,QHC,QHE,QHE/A,QHP1,QHP1/A,QHQ4,QHQ4/A,QH2,QKA4,QKA4/A,QL2,QMEO,QMEO/A,QME8,QME8/A,QMH,QMH/A,QMT2,QMT2/A,QMX2,QNE,QNE2,QNE2/A,QNE6,QNE9,QNE9/A,QNR2,QNR2/A,QNR6,QNR6/A,QN18,QP,QP/A,QPE2,QT,QT/A,QTC2,QTC2/A,QWH2,QWH2/A,QX,QX/A,QXB,QXB/A,QXB7,QXB7/A,QXC,QXC/A,QXC4,QXC4/A,QXC6,QXC6/A,QXC9,QXC9/A,QXE,QXE/A,QXEB,QXE2,QXE4,QXE4/A,QXE6,QXE6/A,QXE8,QXE8/A,QXQ4,QXQ4/A,QXU,QXU/A,QX2,SE,SE/A,SH,SH/A,SHB1,SHB3,SHB3/A,SHE,SHEZ,SHQ4,SHQ4/A,SHT,SJ,SJ/A,SJG,SJG/A,SKE,SKE/A,SKZ,SKZ/A,SME0,SME0/A,SME2,SMX2,SMX2/A,STP,STP/A,STQ,STQ/A,STR,STR/A,SWX,SWX/A,SX,SX/A,SXB,SXB/A,SXB7,SXB7/A,SXE,SXE/A,SXEB,SXEB/A,SXE2,SXE4,SXE4/A,SXE8,SXE8/A,SXP,SXQ4,SXQ4/A,SXU,SXU/A,VA,VAA,VAAE,VAD2,VAD2/A,VAH1,VAH2,VAW1,VA2,VA2/A,VDE,VDE2,VDE2/A,VD16,VE,VEB6,VH,VHE,VH12,VH12/A,VH22,VH22/A,VMX,VNG,VNG1,VNG2,VSH7,VWA,VWA2,VWC2,VWC2/A,VWE2,VWE2/A,VWS2,VWS2/A,VW12,VW12/A,VX,VX/A,VXA,VXB,VXB/A,VXB2,VXB7,VXB7/A,VXE,VXE/A,VXEB,VXEB/A,VXE2,VXE2/A,VXE4,VXE6,VXE7,VXE7/A,VXE8,VXE8/A,VXG,VXK,VXQ4,VXQ4/A,VXU,VXU/A,VXU1,VXU1/A,VX16,VX16/A,VX8,VX8/A,YJ	
			-	(1)	-		
25	16615-ZE2-810	SPRING, RETURN .....	1	-	-	LKE,LKE/A,LWD,SDE,STJ,STJ/A	
			-	(1)	-		
26	16953-ZE1-811	LEVER, COCK .....	1	(1)	-	BE47A A LHC,L1,P1,QHC,QXC,QXC4,Q1,SHT,S1,V1	
		(CARBURETOR NO.)	1	-	-	BE34B B BJ,ED7,ED8,ED9,EN,ES,ES1,ET,ETS,ETX,HA,HH,HX,LH,LHB1,LHB3,LHE,LHQ4,LJ,LJG,LKE,LP,LX,LXE,LXE4,LXQ4,LXZ,PX,QA,QAE,QAP,QAPE,QE,QH,QHB3,QHE,QHQ4,QMEO,QNE,QN18,QP,QT,QX,QXB,QXE,QXEB,QXE4,QXQ4,SDE,SE,SH,SHB1,SHB3,SHE,SHEZ,SHQ4,SJ,SJG,SKZ,SME0,STJ,STP,STQ,SWX,SX,SXB,SXE,SXEB,SXE4,SXP,SXQ4,VA,VAA,VAAE,VAH1,VAH2,VAW1,VDE,VD16,VE,VEB6,VH,VHE,VNG,VNG1,VNG2,VWA,VX,VXA,VXB,VXE,VXEB,VXE4,VXG,VXQ4,VXU,VXU1,VX16,YJ	
		//	1	-	-	BE80A A HAQ,QAQ,QNE9	
		//	1	-	-	BE80B A HA2,HX2,HX26,LXE2,LXE6,LX2,LX26,PKT2,QAE2,QAE6,QAP2,QA2,QA26,QH2,QMT2,QNE2,QNE6,QNR2,QNR6,QPE2,QTC2,QXE2,QXE6,QX2,SME2,SMX2,SXE2,VAD2,VA2,VDE2,VH12,VH22,VWA2,VWC2,VWE2,VWS2,VW12,VXB2,VXE2,VXE6	
		//	1	-	-	BE80C A QDW9,QXC6,QXC9	



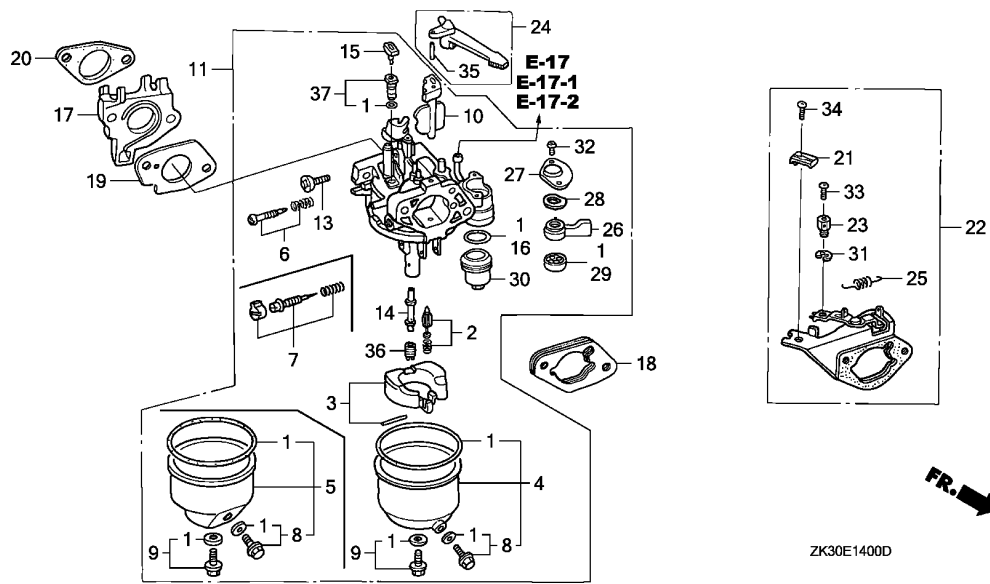

2

Ref. No.	Part No.	Description	Reqd. QTY			Serial No.	Parts catalogue code
			GX	340K1			
26)	16953-ZE1-812	LEVER, COCK .....	1	(1)	(3)	-----	EDK,EDN5,EDN5/A,ED8/A,ED9/A,ES1/A,ES2,HA2/A,HX26/A,LH/A,LHB3/A,LHB5,LHE/A,LHQ4/A,LHW,LJ/A,LJG/A,LJS,LJS/A,LJS1,LKE/A,LSX,LT,LT/A,LWD,LX/A,LXE/A,LXE2/A,LXE4/A,LXE8,LXE8/A,LXQ4/A,LXU,LXU/A,LX2/A,LX26/A,L1/A,PKT2/A,PKT4,PKT4/A,PKX2,PKX4,PKX4/A,PX/A,PXA2,PXE8,PXE8/A,P1/A,QAB2,QAB2/A,QAC2,QAC2/A,QAE2/A,QAE6/A,QAG,QAG/A,QA2,QA2/A,QAP2/A,QA2/A,QA26/A,QDW9/A,QE/A,QH/A,QHB3/A,QHB5,QHE/A,QHP1,QHP1/A,QHQ4/A,QKA4,QKA4/A,QL2,QMEO/A,QME8,QME8/A,QMH,QMH/A,QMT2/A,QMX2,QNE2/A,QNE9/A,QNR2/A,QNR6/A,QP/A,QT/A,QTC2/A,QWH2,QWH2/A,QX/A,QXB/A,QXB7,QXB7/A,QXC/A,QXC4/A,QXC6/A,QXC9/A,QXE/A,QXE4/A,QXE6/A,QXE8,QXE8/A,QXQ4/A,QXU,QXU/A,Q1/A,SE/A,SH/A,SHB3/A,SHQ4/A,SJ/A,SJG/A,SKE,SKE/A,SKZ/A,SMEO/A,SMX2/A,STJ/A,STP/A,STQ/A,STR,STR/A,SWX/A,SX/A,SXB/A,SXB7,SXB7/A,SXE/A,SXEB/A,SXE4/A,SXE8,SXE8/A,SXQ4/A,SXU,SXU/A,S1/A,VAD2/A,VA2/A,VDE2/A,VH12/A,VH22/A,VMX,VSH7,VWC2/A,VWE2/A,VWS2/A,VW12/A,VX/A,VXB/A,VXB7,VXB7/A,VXE/A,VXE8/A,VXE2/A,VXE7,VXE7/A,VXE8,VXE8/A,VXK,VXQ4/A,VXU/A,VXU1/A,VX16/A,VX8,VX8/A



Ref. No.	Part No.	Description	Reqd. QTY			Serial No.	Parts catalogue code
			(1)	(2)	(3)		
26)	16953-ZE1-812	LEVER, COCK ..... (CARBURETOR NO.)	1	(1)	-	BE34B C	----- BJ, ED7, ED8, ED9, EN, ES, ES1, ET, ETS, ETX, HA, HH, HX, LH, LHB1, LHB3, LHE, LHQ4, LJ, LJG, LKE, LP, LX, LXE, LXE4, LXQ4, LXZ, L1, PX, P1, QA, QAE, QAP, QAPE, QE, QH, QHB3, QHE, QHQ4, QMEO, QNE, QN18, QP, QT, QX, QXB, QXE, QXEB, QXE4, QXQ4, Q1, SDE, SE, SH, SHB1, SHB3, SHE, SHEZ, SHQ4, SJ, SJG, SKZ, SMEO, STJ, STP, STQ, SWX, SX, SXB, SXE, SXEB, SXE4, SXP, SXQ4, S1, VA, VAA, VAAE, VAH1, VAH2, VAW1, VDE, VD16, VE, VEB6, VH, VHE, VNG, VNG1, VNG2, VWA, VX, VXA, VXB, VXE, VXEB, VXE4, VXG, VXQ4, VXU, VXU1, VX16, V1, YJ
		//	1	-	-	BE47A B	----- LHC, QHC, QXC, QXC4, SHT
		//	1	-	-	BE80A B	----- HAQ, QAQ, QNE9
		//	1	-	-	BE80B B	----- HA2, HX2, HX26, LXE2, LXE6, LX2, LX26, PKT2, QAE2, QAE6, QAP2, QA2, QA26, QH2, QMT2, QNE2, QNE6, QNR2, QNR6, QPE2, QTC2, QXE2, QXE6, QX2, SME2, SMX2, SXE2, VAD2, VA2, VDE2, VH12, VH22, VWA2, VWC2, VWE2, VWS2, VW12, VXB2, VXE2, VXE6, QDW9, QXC6, QXC9
		//	1	-	-	BE80C B	-----
27	16954-ZE1-811	PLATE, LEVER SETTING ..... (CARBURETOR NO.)	1	-	-	BE34B B	ED7, ED8, ED9, EN, ES, ES1, ET, ETS, ETX, HH, HX, LH, LHB1, LHB3, LHE, LHQ4, LKE, LP, LXE, LXE4, LXQ4, LXZ, PX, QE, QH, QHB3, QHE, QHQ4, QMEO, QP, QT, QX, QXB, QXE, QXEB, QXE4, QXQ4, SE, SH, SHB1, SHB3, SHE, SHEZ, SHQ4, SMEO, SWX, SX, SXB, SXE, SXEB, SXE4, SXQ4, VAA, VAAE, VD16, VE, VEB6, VH, VHE, VNG, VNG1, VNG2, VX, VXB, VXEB, VXE4, VXG, VXQ4, VXU, VXU1, VX16
		//	1	-	-	BE47A A	LHC, QHC, QXC4, SHT
		//	1	-	-	BE80B A	HX26, LXE2, LXE6, LX26, PKT2, QAE6, QA26, QMT2, QNE6, QNR2, QNR6, QTC2, QXE6, SME2, SMX2, SXE2, VAD2, VDE2, VH22, VWA2, VWC2, VWE2, VWS2, VW12, VXB2, VXE6
		//	1	-	-	BE80B B	HA2, HX2, LX2, QAE2, QAP2, QA2, QH2, QNE2, QPE2, QXE2, QX2, VA2, VH12, VXE2
	16954-ZE1-812	..... (CARBURETOR NO.)	1	-	-	-----	BJ, EDK, EDN5, EDN5/A, ED8/A, ED9/A, ES1/A, ES2, HA, HA2, HA2/A, HX26/A, LH/A, LHB3/A, LHB5, LHE/A, LHQ4/A, LHW, LJ, LJ/A, LJG, LJG/A, LJS, LJS/A, LJS1, LKE/A, LSX, LT, LT/A, LWD, LX, LX/A, LXE/A, LXE2/A, LXE4/A, LXEB, LXEB/A, LXQ4/A, LXU, LXU/A, LX2/A, LX26/A, PKT2/A, PKT4, PKT4/A, PKX2, PKX4, PX/A, PXA2, PXE8, PXE8/A, QA, QAB2, QAB2/A, QAC2, QAC2/A, QAE, QAE2/A, QAE6/A, QAG, QAG/A, QAH2, QAH2/A, QAP, QAPE, QAP2/A, QA2/A, QA26/A, QDW9/A, QE/A, QH/A, QHB3/A, QHB5, QHE/A, QHP1, QHP1/A, QHQ4/A, QKA4, QKA4/A, QL2, QMEO/A, QME8, QME8/A, QMH, QMH/A, QMT2/A, QMX2, QNE, QNE2/A, QNE9/A, QNR2/A, QNR6/A, QN18, QP/A, QT/A, QTC2/A, QWH2, QWH2/A, QX/A, QXB/A, QXB7, QXB7/A, QXC, QXC/A, QXC4/A, QXC6/A, QXC9/A, QXE/A, QXE4/A, QXE6/A, QXE8, QXE8/A, QXQ4/A, QXU, QXU/A, SDE, SE/A, SH/A, SHB3/A, SHQ4/A, SJ, SJ/A, SJG, SJG/A, SKE, SKE/A, SKZ, SKZ/A, SMEO/A, SMX2/A, STJ, STJ/A, STP, STP/A, STQ, STQ/A, STR, STR/A, SWX/A, SX/A, SXB/A, SXB7, SXB7/A, SXE/A, SXEB/A, SXE4/A, SXE8, SXE8/A, SXP, SXQ4/A, SXU, SXU/A, VA, VAD2/A, VAH1, VAH2, VAW1, VA2/A, VDE, VDE2/A, VH12/A, VH22/A, VMX, VSH7, VWA, VWC2/A, VWE2/A, VWS2/A, VW12/A, VX/A, VXA, VXB/A, VXB7, VXB7/A, VXE, VXE/A, VXEB/A, VXEB7/A, VXE7, VXE7/A, VXE8, VXE8/A, VXE, VXQ4/A, VXU/A, VXU1/A, VX16/A, VX8, VX8/A, YJ
		//	1	-	-	BE34B C	----- ED7, ED8, ED9, EN, ES, ES1, ET, ETS, ETX, HH, HX, LH, LHB1, LHB3, LHE, LHQ4, LKE, LP, LXE, LXE4, LXQ4, LXZ, PX, QE, QH, QHB3, QHE, QHQ4, QMEO, QP, QT, QX, QXB, QXE, QXEB, QXE4, QXQ4, SE, SH, SHB1, SHB3, SHE, SHEZ, SHQ4, SMEO, SWX, SX, SXB, SXE, SXEB, SXE4, SXQ4, VAA, VAAE, VD16, VE, VEB6, VH, VHE, VNG, VNG1, VNG2, VX, VXB, VXEB, VXE4, VXG, VXQ4, VXU, VXU1, VX16
		//	1	-	-	BE47A B	LHC, QHC, QXC4, SHT
		//	1	-	-	BE80A B	HAQ, QAQ, QNE9
		//	1	-	-	BE80B B	HA2, HX2, HX26, LXE2, LXE6, LX2, LX26, PKT2, QAE2, QAE6, QAP2, QA2, QA26, QH2, QMT2, QNE2, QNE6, QNR2, QNR6, QPE2, QTC2, QXE2, QXE6, QX2, SME2, SMX2, SXE2, VAD2, VA2, VDE2, VH12, VH22, VWA2, VWC2, VWE2, VWS2, VW12, VXB2, VXE2, VXE6, QDW9, QXC6, QXC9
		//	1	-	-	BE80C B	-----
		//	-	(1)	-	-----	
	16954-ZF0-841	..... (CARBURETOR NO.)	1	-	-	BE80A A	HAQ, QAQ, QNE9
		//	1	-	-	BE80C A	QDW9, QXC6, QXC9



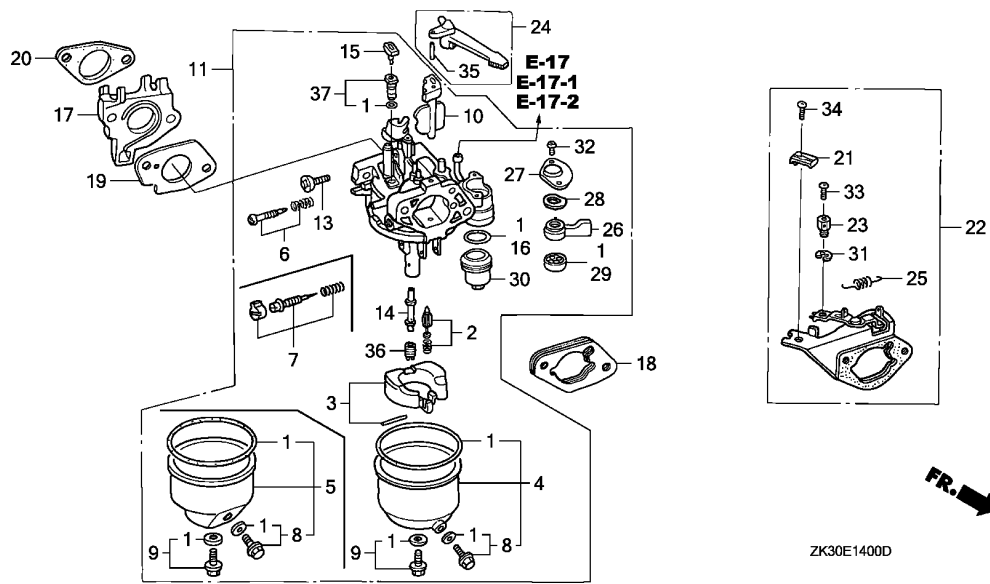

2

Ref. No.	Part No.	Description	Reqd. QTY			Serial No.	Parts catalogue code
			GX	340K1			
			(1)	(2)	(3)		
28	16956-ZE1-811	SPRING, COCK LEVER .....	1	-	-	-----	BJ,EDK,EDN5,EDN5/A,ED7,ED8,ED8/A,ED9,ED9/A,EN,ES,ES1,ES1/A,ES2,ETS,ETX,HA,HAQ,HA2,HA2/A,HH,HX,HX2,HX26,HX26/A,LH,LH/A,LHB1,LHB3,LHB3/A,LHB5,LHC,LHE,LHE/A,LHQ4,LHQ4/A,LHW,LJ,LJ/A,LJG,LJG/A,LJS,LJS/A,LJS1,LKE,LKE/A,LP,LSX,LT,LT/A,LWD,LX,LX/A,LXE,LXE/A,LXE2,LXE2/A,LXE4,LXE4/A,LXE6,LXE8,LXE8/A,LXQ4,LXQ4/A,LXU,LXU/A,LXZ,LX2,LX2/A,LX26,LX26/A,PKT2,PKT2/A,PKT4,PKT4/A,PKX2,PKX4,PKX4/A,PX,PX/A,PXA2,PXE8,PXE8/A,QA,QAB2,QAB2/A,QAC2,QAC2/A,QAE,QAE2,QAE2/A,QAE6,QAE6/A,QAG,QAG/A,QA2,QA2/A,QAH2,QAH2/A,QAP,QAPE,QAPE2,QAPE2/A,QAQ,QA2,QA2/A,QA26,QA26/A,QDW9,QDW9/A,QE,QE/A,QH,QH/A,QHB3,QHB3/A,QHB5,QHC,QHE,QHE/A,QHP1,QHP1/A,QHQ4,QHQ4/A,QH2,QKA4,QKA4/A,QL2,QMEO,QMEO/A,QME8,QME8/A,QMH,QMH/A,QMT2,QMT2/A,QMX2,QNE,QNE2,QNE2/A,QNE6,QNE9,QNE9/A,QNR2,QNR2/A,QNR6,QNR6/A,QN18,QP,QP/A,QPE2,QT,QT/A,QTC2,QTC2/A,QWH2,QWH2/A,QX,QX/A,QXB,QXB/A,QXB7,QXB7/A,QXC,QXC/A,QXC4,QXC4/A,QXC6,QXC6/A,QXC9,QXC9/A,QXE,QXE/A,QXEB,QXE2,QXE4,QXE4/A,QXE6,QXE6/A,QXE8,QXE8/A,QXQ4,QXQ4/A,QXU,QXU/A,QX2,SDE,SE,SE/A,SH,SH/A,SHB1,SHB3,SHB3/A,SHE,SHEZ,SHQ4,SHQ4/A,SHT,SJ,SJ/A,SJG,SJG/A,SKE,SKE/A,SKZ,SKZ/A,SMEO,SMEO/A,SMX2,SMX2/A,STJ,STJ/A,STP,STP/A,STQ,STQ/A,STR,STR/A,SWX,SWX/A,SX,SX/A,SXB,SXB/A,SXB7,SXB7/A,SXE,SXE/A,SXEB,SXEB/A,SXE2,SXE4,SXE4/A,SXE8,SXE8/A,SXP,SXQ4,SXQ4/A,SXU,SXU/A,VA,VAA,VAE,VAD2,VAD2/A,VAH1,VAH2,VAW1,VA2,VA2/A,VDE,VDE2,VDE2/A,VD16,VE,VEB6,VH,VHE,VH12,VH12/A,VH22,VH22/A,VMX,VNG,VNG1,VNG2,VSH7,VVA,VVA2,VWC2,VWC2/A,VWE2,VWE2/A,VWS2,VWS2/A,VW12,VW12/A,VX,VX/A,VXA,VXB,VXB/A,VXB2,VXB7/VXB7/A,VXE,VXE/A,VXEB,VXEB/A,VXE2,VXE2/A,VXE4,VXE6,VXE7,VXE7/A,VXE8,VXE8/A,VXG,VXK,VXQ4,VXQ4/A,VXU,VXU/A,VXU1,VXU1/A,VX16,VX16/A,VX8,VX8/A,YJ

- (1) -

Ref. No.	Part No.	Description	Reqd. QTY			Serial No.	Parts catalogue code
			(1)	(2)	(3)		
29	16957-ZE1-812	PACKING, FUEL COCK .....	1	-	-	-----	BJ,EDK,EDN5,EDN5/A,ED7,ED8,ED8/A,ED9,ED9/A,EN,ES,ES1,ES1/A,ES2,ETS,ETX,HA,HAQ,HA2,HA2/A,HH,HX,HX2,HX26,HX26/A,LH,LH/A,LHB1,LHB3,LHB3/A,LHB5,LHC,LHE,LHE/A,LHQ4,LHQ4/A,LHW,LJ,LJ/A,LJG,LJG/A,LJS,LJS/A,LJS1,LKE,LKE/A,LP,LSX,LT,LT/A,LWD,LX,LX/A,LXE,LXE/A,LXE2,LXE2/A,LXE4,LXE4/A,LXE6,LXE8,LXE8/A,LXQ4,LXQ4/A,LXU,LXU/A,LXZ,LXZ/A,LX2/A,LX26,LX26/A,PKT2,PKT2/A,PKT4,PKT4/A,PKX2,PKX4,PKX4/A,PX,PX/A,PXA2,PXE8,PXE8/A,QA,QAB2,QAB2/A,QAC2,QAC2/A,QAQ,QAQ2,QAQ2/A,QAQ,QA2,QA2/A,QA26,QA26/A,QDW9,QDW9/A,QE,QE/A,QH,QH/A,QHB3,QHB3/A,QHB5,QHC,QHE,QHE/A,QHP1,QHP1/A,QHQ4,QHQ4/A,QH2,QKA4,QKA4/A,QL2,QMEO,QMEO/A,QME8,QME8/A,QMH,QMH/A,QMT2,QMT2/A,QMX2,QNE,QNE2,QNE2/A,QNE6,QNE9,QNE9/A,QNR2,QNR2/A,QNR6,QNR6/A,QN18,QP,QP/A,QPE2,QT,QT/A,QTC2,QTC2/A,QWH2,QWH2/A,QX,QX/A,QXB,QXB/A,QXB7,QXB7/A,QXC,QXC/A,QXC4,QXC4/A,QXC6,QXC6/A,QXC9,QXC9/A,QXE,QXE/A,QXEB,QXE2,QXE4,QXE4/A,QXE6,QXE6/A,QXE8,QXE8/A,QXQ4,QXQ4/A,QXU,QXU/A,QX2,SDE,SE,SE/A,SH,SH/A,SHB1,SHB3,SHB3/A,SHE,SHEZ,SHQ4,SHQ4/A,SHT,SJ,SJ/A,SJG,SJG/A,SKE,SKE/A,SKZ,SKZ/A,SMEO,SMEO/A,SMZ2,SMX2,SMX2/A,STJ,STJ/A,STP,STP/A,STQ,STQ/A,STR,STR/A,SWX,SWX/A,SX,SX/A,SXB,SXB/A,SXB7,SXB7/A,SXE,SXE/A,SXEB,SXEB/A,SXE2,SXE4,SXE4/A,SXE8,SXE8/A,SXP,SXQ4,SXQ4/A,SXU,SXU/A,VA,VAA,VAAE,VAD2,VAD2/A,VAH1,VAH2,VAW1,VA2,VA2/A,VDE,VDE2,VDE2/A,VD16,VE,VEB6,VH,VHE,VH12,VH12/A,VH22,VH22/A,VMX,VNG,VNG1,VNG2,VSH7,VWA,VWA2,VWC2,VWC2/A,VWE2,VWE2/A,VWS2,VWS2/A,VW12,VW12/A,VX,VX/A,VXA,VXB,VXB/A,VXB2,VXB7,VXB7/A,VXE,VXE/A,VXEB,VXEB/A,VXE2,VXE2/A,VXE4,VXE6,VXE7,VXE7/A,VXE8,VXE8/A,VXG,VXK,VXQ4,VXQ4/A,VXU,VXU/A,VXU1,VXU1/A,VX16,VX16/A,VX8,VX8/A,YJ
			-	(1)	-		
30	16967-ZE0-811	CUP, FUEL STRAINER .....	1	-	-	-----	BJ,EDK,EDN5,EDN5/A,ED7,ED8,ED8/A,ED9,ED9/A,EN,ES,ES1,ES1/A,ES2,ETS,ETX,HA,HAQ,HA2,HA2/A,HH,HX,HX2,HX26,HX26/A,LH,LH/A,LHB1,LHB3,LHB3/A,LHB5,LHC,LHE,LHE/A,LHQ4,LHQ4/A,LHW,LJ,LJ/A,LJG,LJG/A,LJS,LJS/A,LJS1,LKE,LKE/A,LP,LSX,LT,LT/A,LWD,LX,LX/A,LXE,LXE/A,LXE2,LXE2/A,LXE4,LXE4/A,LXE6,LXE8,LXE8/A,LXQ4,LXQ4/A,LXU,LXU/A,LXZ,LXZ/A,LX2/A,LX26,LX26/A,PKT2,PKT2/A,PKT4,PKT4/A,PKX2,PKX4,PKX4/A,PX,PX/A,PXA2,PXE8,PXE8/A,QA,QAB2,QAB2/A,QAC2,QAC2/A,QAQ,QAQ2,QAQ2/A,QAQ,QA2,QA2/A,QA26,QA26/A,QDW9,QDW9/A,QE,QE/A,QH,QH/A,QHB3,QHB3/A,QHB5,QHC,QHE,QHE/A,QHP1,QHP1/A,QHQ4,QHQ4/A,QH2,QKA4,QKA4/A,QL2,QMEO,QMEO/A,QME8,QME8/A,QMH,QMH/A,QMT2,QMT2/A,QMX2,QNE,QNE2,QNE2/A,QNE6,QNE9,QNE9/A,QNR2,QNR2/A,QNR6,QNR6/A,QN18,QP,QP/A,QPE2,QT,QT/A,QTC2,QTC2/A,QWH2,QWH2/A,QX,QX/A,QXB,QXB/A,QXB7,QXB7/A,QXC,QXC/A,QXC4,QXC4/A,QXC6,QXC6/A,QXC9,QXC9/A,QXE,QXE/A,QXEB,QXE2,QXE4,QXE4/A,QXE6,QXE6/A,QXE8,QXE8/A,QXQ4,QXQ4/A,QXU,QXU/A,QX2,SDE,SE,SE/A,SH,SH/A,SHB1,SHB3,SHB3/A,SHE,SHEZ,SHQ4,SHQ4/A,SHT,SJ,SJ/A,SJG,SJG/A,SKE,SKE/A,SKZ,SKZ/A,SMEO,SMEO/A,SMZ2,SMX2,SMX2/A,STJ,STJ/A,STP,STP/A,STQ,STQ/A,STR,STR/A,SWX,SWX/A,SX,SX/A,SXB,SXB/A,SXB7,SXB7/A,SXE,SXE/A,SXEB,SXEB/A,SXE2,SXE4,SXE4/A,SXE8,SXE8/A,SXP,SXQ4,SXQ4/A,SXU,SXU/A,VA,VAA,VAAE,VAD2,VAD2/A,VAH1,VAH2,VAW1,VA2,VA2/A,VDE,VDE2,VDE2/A,VD16,VE,VEB6,VH,VHE,VH12,VH12/A,VH22,VH22/A,VMX,VNG,VNG1,VNG2,VSH7,VWA,VWA2,VWC2,VWC2/A,VWE2,VWE2/A,VWS2,VWS2/A,VW12,VW12/A,VX,VX/A,VXA,VXB,VXB/A,VXB2,VXB7,VXB7/A,VXE,VXE/A,VXEB,VXEB/A,VXE2,VXE2/A,VXE4,VXE6,VXE7,VXE7/A,VXE8,VXE8/A,VXG,VXK,VXQ4,VXQ4/A,VXU,VXU/A,VXU1,VXU1/A,VX16,VX16/A,VX8,VX8/A,YJ
			-	(1)	-		
31	90605-230-000	CIRCLIP, 5MM .....	1	-	-	-----	LKE,LKE/A,LWD,SDE,STJ,STJ/A
			-	(1)	-		



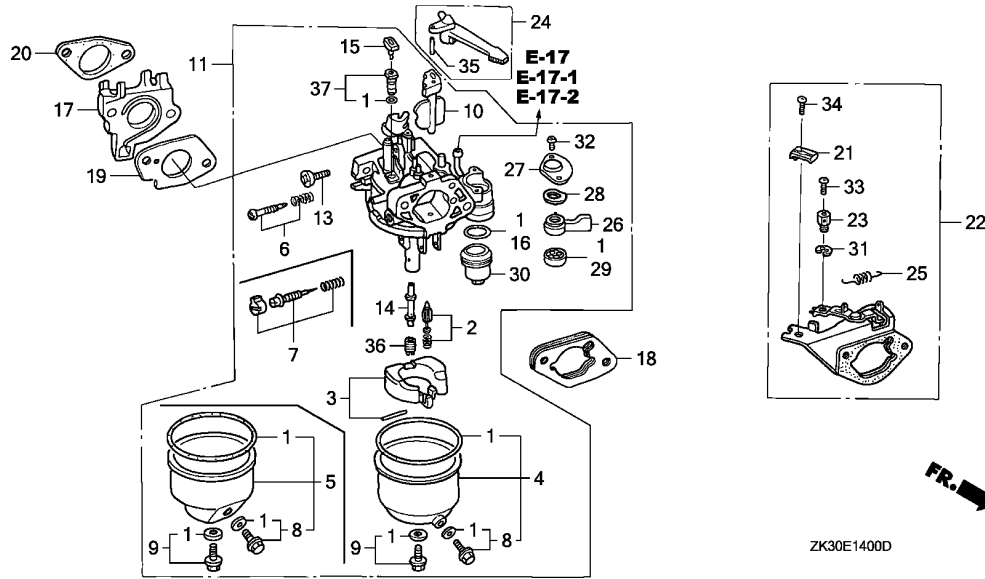

2

Ref. No.	Part No.	Description	Reqd. QTY			Serial No.	Parts catalogue code
			GX	340K1	(3)		
	32 93500-03008-1G	SCREW, PAN, 3X8 (CARBURETOR NO.)	2	(2)	-	BE34B B BJ, ED7, ED8, ED9, EN, ES, ES1, ET, ETS, ETX, HA, HH, HX, LH, LHB1, LHB3, LHE LHQ4, LJ, LJG, LKE, LP, LX, LXE, LXE4, LXQ4, LXZ, L1, PX, P1, QA, QAE, QAP, QAPE QE, QH, QHB3, QHE, QHQ4, QMED, QNE, QN18, QP, QT, QX, QXB, QXE, QXEB, QXE4, QXQ4 Q1, SDE, SE, SH, SHB1, SHB3, SHE, SHEZ, SHQ4, SJ, SJG, SKZ, SMEO, STJ, STP, STQ SWX, SX, SXB, SXE, SXEB, SXE4, SXP, SXQ4, S1, VA, VAA, VAAE, VAH1, VAH2, VAW1 VDE, VD16, VE, VEB6, VH, VHE, VNG, VNG1, VNG2, VWA, VX, VXA, VXB, VXE, VXEB VXE4, VXG, VXQ4, VXU, VXU1, VX16, V1, YJ	
	//		2	-	-	BE47A A LHC, QHC, QXC, QXC4, SHT	
	//		2	-	-	BE80A A HAQ, QAQ, QNE9	
	//		2	-	-	BE80B A HA2, HX2, HX26, LXE2, LXE6, LX2, LX26, PKT2, QAE2, QAE6, QAP2, QA2, QA26, QH2 QMT2, QNE2, QNE6, QNR2, QNR6, QPE2, QTC2, QXE2, QXE6, QX2, SME2, SMX2, SXE2 VAD2, VA2, VDE2, VH12, VH22, VWA2, VMC2, VWE2, VWS2, VW12, VXB2, VXE2, VXE6	
	//		2	-	-	BE80C A QDW9, QXC6, QXC9	

Ref. No.	Part No.	Description	Reqd. QTY			Serial No.	Parts catalogue code	
			(1)	(2)	(3)			
32)	93500-03006-1H	SCREW, PAN, 3X6 .....	2	(2)	-	-----	EDK,EDN5,EDN5/A,ED8/A,ED9/A,ES1/A,ES2,HA2/A,HX26/A,LH/A,LHB3/A,LHB5,LHE/A,LHQ4/A,LHW,LJ/A,LJG/A,LJS,LJS/A,LJS1,LKE/A,LSX,LT,LT/A,LWD,LX/A,LXE/A,LXE2/A,LXE4/A,LXE8,LXE8/A,LXQ4/A,LXU,LXU/A,LX2/A,LX26/A,L1/A,PKT2/A,PKT4,PKT4/A,PKX2,PKX4,PKX4/A,PX/A,PXA2,PXE8,PXE8/A,P1/A,QAB2,QAB2/A,QAC2,QAC2/A,QAE2/A,QAE6/A,QAG,QAG/A,QA2,QA2/A,QAP2/A,QA2/A,QA26/A,QDW9/A,QE/A,QH/A,QHB3/A,QHB5,QHE/A,QHP1,QHP1/A,QHQ4/A,QKA4,QKA4/A,QL2,QMEO/A,QME8,QME8/A,QMH,QMH/A,QMT2/A,QMX2,QNE2/A,QNE9/A,QNR2/A,QNR6/A,QP/A,QT/A,QTC2/A,QWH2,QWH2/A,QX/A,QXB/A,QXB7,QXB7/A,QXC/A,QXC4/A,QXC6/A,QXC9/A,QXE/A,QXE4/A,QXE6/A,QXE8,QXE8/A,QXQ4/A,QXU,QXU/A,Q1/A,SE/A,SH/A,SHB3/A,SHQ4/A,SJ/A,SJG/A,SKE,SKE/A,SKZ/A,SMEO/A,SMX2/A,STJ/A,STP/A,STQ/A,STR,STR/A,SWX/A,SX/A,SXB/A,SXB7,SXB7/A,SXE/A,SXEB/A,SXE4/A,SXE8,SXE8/A,SXQ4/A,SXU,SXU/A,S1/A,VAD2/A,VA2/A,VDE2/A,VH12/A,VH22/A,VMX,VSH7,VWC2/A,VWE2/A,VWS2/A,VW12/A,VX/A,VXB/A,VXB7,VXB7/A,VXE/A,VXEB/A,VXE2/A,VXE7,A,VXE8,VXE8/A,VXK,VXQ4/A,VXU/A,VXU1/A,VX16/A,VX8,VX8/A	
		(CARBURETOR NO.)	2	(2)	-	BE34B C	-----	BJ,ED7,ED8,ED9,EN,ES,ES1,ET,ETS,ETX,HA,HH,HX,LH,LHB1,LHB3,LHE,LHQ4,LJ,LJG,LKE,LP,LX,LXE,LXE4,LXQ4,LXZ,L1,PX,P1,QA,QAQ,QAP,QAPE,QE,QH,QHB3,QHE,QHQ4,QMEO,QNE,QN18,QP,QT,QX,QXB,QXE,QXEB,QXE4,QXQ4,Q1,SDE,SE,SH,SHB1,SHB3,SHE,SHEZ,SHQ4,SJ,SJG,SKZ,SMEO,STJ,STP,STQ,SWX,SX,SXB,SXE,SXEB,SXE4,SXP,SXQ4,S1,VA,VAA,VAE,VAH1,VAH2,VAW1,VDE,VD16,VE,VEB6,VH,VHE,VNG,VNG1,VNG2,VWA,VX,VXA,VXB,VXE,VXEB,VXE4,VXG,VXQ4,VXU,VXU1,VX16,V1,YJ
		//	2	-	-	BE47A B	-----	LHC,QHC,QXC,QXC4,SHT
		//	2	-	-	BE80A B	-----	HAQ,QAQ,QNE9
		//	2	-	-	BE80B B	-----	HA2,HX2,HX26,LXE2,LXE6,LX2,LX26,PKT2,QAE2,QAE6,QAP2,QA2,QA26,QH2,QMT2,QNE2,QNE6,QNR2,QNR6,QPE2,QTC2,QXE2,QXE6,QX2,SMEO,SMX2,SXE2,VAD2,VA2,VDE2,VH12,VH22,VWA2,VWC2,VWE2,VWS2,VW12,VXB2,VXE2,VXE6,QDW9
		//	2	-	-	BE80C A	-----	QXC6,QXC9
		//	2	-	-	BE80C B	-----	LKE,LKE/A,LWD,SDE,STJ,STJ/A
33	93500-04006-0H	SCREW, PAN, 4X6 .....	1	-	-	-----	-----	LKE,LKE/A,LWD,SDE,STJ,STJ/A
34	93893-05016-00	SCREW-WASHER, 5X16 .....	1	-	-	-----	-----	LKE,LKE/A,LWD,SDE,STJ,STJ/A
			-	(1)	-	-----	-----	



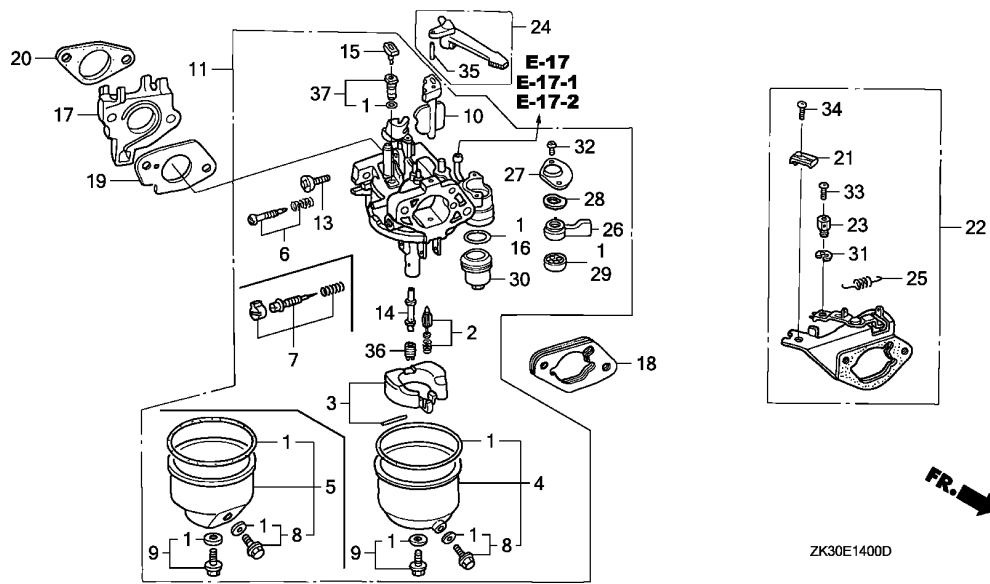

2

Ref. No.	Part No.	Description	Reqd. QTY			Serial No.	Parts catalogue code
			GX	340K1	(3)		
			(1)	(2)	(3)		
35	94305-20122	PIN, SPRING, 2X12 .....	1	-	-	-----	BJ,EDK,EDN5,EDN5/A,ED7,ED8,ED8/A,ED9,ED9/A,EN,ES,ES1,ES1/A,ES2,ETS,ETX,HA,HAQ,HA2,HA2/A,HH,HX,HX2,HX26,HX26/A,LH,LH/A,LHB1,LHB3,LHB3/A,LHB5,LHC,LHE,LHE/A,LHQ4,LHQ4/A,LHW,LJ,LJ/A,LJG,LJG/A,LJS,LJS/A,LJS1,LP,LSX,LT,LT/A,LX,LX/A,LXE,LXE/A,LXE2,LXE2/A,LXE4,LXE4/A,LXE6,LXE8,LXE8/A,LXQ4,LXQ4/A,LXU,LXU/A,LXZ,LXZ/A,LX26,LX26/A,PKT2,PKT2/A,PKT4,PKT4/A,PKX2,PKX4,PKX4/A,PX,PX/A,PXA2,PXE8,PXE8/A,QA,QAB2,QAB2/A,QAC2,QAC2/A,QAE,QAE2,QAE2/A,QAE6,QAE6/A,QAG,QAG/A,QA2,QA2/A,QAP,QAPE,QAP2,QAP2/A,QAQ,QA2,QA2/A,QA26,QA26/A,QDW9,QDW9/A,QE,QE/A,QH,QH/A,QHB3,QHB3/A,QHB5,QHC,QHE,QHE/A,QHP1,QHP1/A,QHQ4,QHQ4/A,QH2,QKA4,QKA4/A,QL2,QMEO,QMED/A,QME8,QME8/A,QMH,QMH/A,QMT2,QMT2/A,QMX2,QNE,QNE2,QNE2/A,QNE6,QNE9,QNE9/A,QNR2,QNR2/A,QNR6,QNR6/A,QN18,QP,QP/A,QPE2,QT,QT/A,QTC2,QTC2/A,QWH2,QWH2/A,QX,QX/A,QXB,QXB/A,QXB7,QXB7/A,QXC,QXC/A,QXC4,QXC4/A,QXC6,QXC6/A,QXC9,QXC9/A,QXE,QXE/A,QXEB,QXE2,QXE4,QXE4/A,QXE6,QXE6/A,QXE8,QXE8/A,QXQ4,QXQ4/A,QXU,QXU/A,QX2,SE,SE/A,SH,SH/A,SHB1,SHB3,SHB3/A,SHE,SHEZ,SHQ4,SHQ4/A,SHT,SJ,SJ/A,SJG,SJG/A,SKE,SKE/A,SKZ,SKZ/A,SME0,SME0/A,SME2,SMX2,SMX2/A,STP,STP/A,STQ,STQ/A,STR,STR/A,SWX,SWX/A,SX,SX/A,SXB,SXB/A,SXB7,SXB7/A,SXE,SXE/A,SXEB,SXEB/A,SXE2,SXE4,SXE4/A,SXE8,SXE8/A,SXP,SXQ4,SXQ4/A,SXU,SXU/A,VA,VA,VAA,VAE,VAD2,VAD2/A,VAH1,VAH2,VAW1,VA2,VA2/A,VDE,VDE2,VDE2/A,VD16,VE,VEB6,VH,VHE,VH12,VH12/A,VH22,VMX,VNG,VNG1,VNG2,VSH7,VWA,VWA2,VWC2,VWC2/A,VWE2,VWE2/A,VWS2,VWS2/A,VW12,VW12/A,VX,VX/A,VXA,VXB,VXB/A,VXB2,VXB7,VXB7/A,VXE,VXE/A,VXEB,VXEB/A,VXE2,VXE2/A,VXE4,VXE6,VXE7,VXE7/A,VXE8,VXE8/A,VXG,VXK,VXQ4,VXQ4/A,VXU,VXU/A,VXU1,VXU1/A,VX16,VX16/A,VX8,VX8/A,YJ
			-	(1)	-		
36	99101-ZH8-1020	JET, MAIN, #102 .....	(1)	(1)	-	-----	LHC,QHC,QXC4,QXC4/A,Q1,Q1/A,SHT,S1,S1/A
		(CARBURETOR NO.)	(1)	-	-	-----	BE47A B QXC

Ref. No.	Part No.	Description	Reqd. QTY			Serial No.	Parts catalogue code
			(1)	(2)	(3)		
36)	99101-ZH8-1050	JET, MAIN, #105 (CARBURETOR NO.)	(1)	(1)	-	-----	LHC,QHC,QXC4,QXC4/A,Q1,Q1/A,SHT,S1,S1/A
	99101-ZH8-1080	JET, MAIN, #108 (CARBURETOR NO.)	(1)	(1)	-	-----	BE47A B QXC
	99101-ZF5-0920	JET, MAIN, #92 (CARBURETOR NO.)	1	-	-	-----	LHC,QHC,QXC4,QXC4/A,Q1,Q1/A,SHT,S1,S1/A
			1	-	-	-----	BE47A B QXC
	99101-ZF5-0950	JET, MAIN, #95 (CARBURETOR NO.)	(1)	(1)	-	-----	BE34B B BJ,ED7,ED8,ED9,EN,ES,ES1,ET,ETS,ETX,HA,HH,HX,LH,LHB1,LHB3,LHE LHQ4,LJ,LJG,LKE,LX,LXE,LXE4,LXQ4,LXZ,L1,PX,P1,QA,QAE,QAP,QAPE,QE QH,QHB3,QHE,QHQ4,QMEO,QNE,QN18,QP,QT,QX,QXB,QXE,QXEB,QXE4,QXQ4,Q1 SDE,SE,SH,SHB1,SHB3,SHE,SHEZ,SHQ4,SJ,SJG,SKZ,SMEO,STJ,STP,STQ,SWX SX,SBX,SXE,SXEB,SXE4,SXP,SXQ4,S1,VA,VAA,VAE,VAH1,VAH2,VAW1,VDE VD16,VE,VEB6,VH,VHE,VNG,VNG1,VNG2,VVA,VX,VXA,VXB,VXE,VXEB,VXE4 VXG,VXQ4,VXU,VXU1,VX16,V1,YJ
	99101-ZF5-0980	JET, MAIN, #98 (CARBURETOR NO.)	1	(1)	-	-----	BE34B B BJ,ED7,ED8,ED9,EN,ES,ES1,ET,ETS,ETX,HA,HH,HX,LH,LHB1,LHB3,LHE LHQ4,LJ,LJG,LKE,LX,LXE,LXE4,LXQ4,LXZ,L1,PX,P1,QA,QAE,QAP,QAPE,QE QH,QHB3,QHE,QHQ4,QMEO,QNE,QN18,QP,QT,QX,QXB,QXE,QXEB,QXE4,QXQ4,Q1 SDE,SE,SH,SHB1,SHB3,SHE,SHEZ,SHQ4,SJ,SJG,SKZ,SMEO,STJ,STP,STQ,SWX SX,SBX,SXE,SXEB,SXE4,SXP,SXQ4,S1,VA,VAA,VAE,VAH1,VAH2,VAW1,VDE VD16,VE,VEB6,VH,VHE,VNG,VNG1,VNG2,VVA,VX,VXA,VXB,VXE,VXEB,VXE4 VXG,VXQ4,VXU,VXU1,VX16,V1,YJ
	99101-ZH8-0920	JET, MAIN, #92 (CARBURETOR NO.)	(1)	(1)	-	-----	LHW,LSX,LT,LT/A,L1/A,PXE8,PXE8/A,P1/A,QKA4,QKA4/A,QME8,QME8/A QP/A,QT/A,Q1/A,STJ/A,SWX/A,S1/A
	//		(1)	-	-	-----	BE34B C BJ,HA,HH,HX,LHB1,LXZ,L1,P1,QA,QAE,QAP,QAPE,QNE,QP,QT,QXEB,Q1,SHEZ STJ,SWX,SXP,S1,VAH1,VAH2,VAW1,VDE,VVA,V1,YJ
	//		(1)	-	-	-----	BE34B C LXE8,LXU,PKX4,QHP1,QMH,QXE8,QXU,SKE,STR,SXE8,SXU
	//		(1)	-	-	-----	BE34B C BE34B C ED7,ED8,ED9,EN,ES,ES1,ET,ETS,ETX,LH,LHB3,LHE,LHQ4,LJ,LJG,LKE,LX LXE,LXE4,LXQ4,PX,QE,QH,QHB3,QHE,QHQ4,QMEO,QN18,QX,QXB,QXE,QXE4 QXQ4,SDE,SE,SH,SHB1,SHB3,SHE,SHQ4,SJ,SJG,SKZ,SMEO,STP,STQ,SX,SBX SXE,SXEB,SXE4,SXQ4,VA,VAA,VAE,VD16,VE,VEB6,VH,VHE,VNG,VNG1,VNG2 VX,VXA,VXB,VXE,VXEB,VXE4,VXG,VXQ4,VXU,VXU1,VX16
	99101-ZH8-0950	JET, MAIN, #95 (CARBURETOR NO.)	(1)	(1)	-	-----	LHW,LSX,LT,LT/A,L1/A,PXE8,PXE8/A,P1/A,QKA4,QKA4/A,QME8,QME8/A QP/A,QT/A,Q1/A,STJ/A,SWX/A,S1/A
	//		(1)	-	-	-----	BE34B C BJ,HA,HH,HX,LHB1,LXZ,L1,P1,QA,QAE,QAP,QAPE,QNE,QP,QT,QXEB,Q1,SHEZ STJ,SWX,SXP,S1,VAH1,VAH2,VAW1,VDE,VVA,V1,YJ
	//		(1)	-	-	-----	BE34B C BE34B C ED7,ED8,ED9,EN,ES,ES1,ET,ETS,ETX,LH,LHB3,LHE,LHQ4,LJ,LJG,LKE,LX LXE,LXE4,LXQ4,PX,QE,QH,QHB3,QHE,QHQ4,QMEO,QN18,QX,QXB,QXE,QXE4 QXQ4,SDE,SE,SH,SHB1,SHB3,SHE,SHQ4,SJ,SJG,SKZ,SMEO,STP,STQ,SX,SBX SXE,SXEB,SXE4,SXQ4,VA,VAA,VAE,VD16,VE,VEB6,VH,VHE,VNG,VNG1,VNG2 VX,VXA,VXB,VXE,VXEB,VXE4,VXG,VXQ4,VXU,VXU1,VX16
	99101-ZH8-0980	JET, MAIN, #98 (CARBURETOR NO.)	1	(1)	-	-----	LHW,LSX,LT,LT/A,L1/A,PXE8,PXE8/A,P1/A,QKA4,QKA4/A,QME8,QME8/A QP/A,QT/A,Q1/A,STJ/A,SWX/A,S1/A
	//		1	(1)	-	-----	BE34B C BJ,HA,HH,HX,LHB1,LXZ,L1,P1,QA,QAE,QAP,QAPE,QNE,QP,QT,QXEB,Q1,SHEZ STJ,SWX,SXP,S1,VAH1,VAH2,VAW1,VDE,VVA,V1,YJ
	//		1	-	-	-----	BE34B C LXE8,LXU,PKX4,QHP1,QMH,QXE8,QXU,SKE,STR,SXE8,SXU
	//		1	-	-	-----	BE34B C BE34B C ED7,ED8,ED9,EN,ES,ES1,ET,ETS,ETX,LH,LHB3,LHE,LHQ4,LJ,LJG,LKE,LX LXE,LXE4,LXQ4,PX,QE,QH,QHB3,QHE,QHQ4,QMEO,QN18,QX,QXB,QXE,QXE4 QXQ4,SDE,SE,SH,SHB1,SHB3,SHE,SHQ4,SJ,SJG,SKZ,SMEO,STP,STQ,SX,SBX SXE,SXEB,SXE4,SXQ4,VA,VAA,VAE,VD16,VE,VEB6,VH,VHE,VNG,VNG1,VNG2 VX,VXA,VXB,VXE,VXEB,VXE4,VXG,VXQ4,VXU,VXU1,VX16



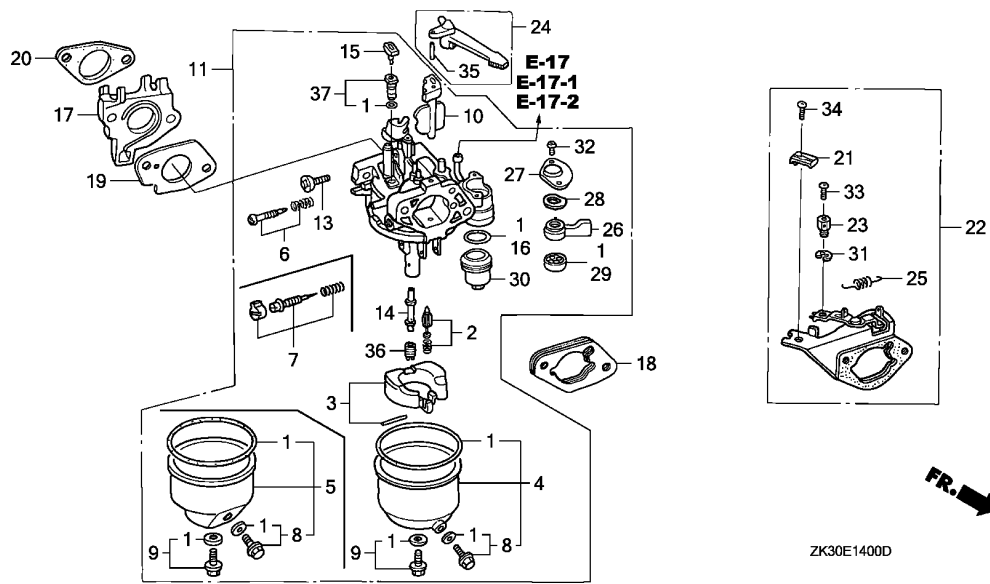

Ref. No.	Part No.	Description	Reqd. QTY			Serial No.	Parts catalogue code
			GX	340K1	(3)		
36)	99101-ZH7-0920	JET, MAIN, #92 (CARBURETOR NO.)	(1)	-	-	-----	BE80A A HAQ,QAQ,QNE9
	99101-ZH7-0950	JET, MAIN, #95 (CARBURETOR NO.)	(1)	-	-	-----	BE80A A HAQ,QAQ,QNE9
	99101-ZH7-0980	JET, MAIN, #98 (CARBURETOR NO.)	1	-	-	-----	BE80A A HAQ,QAQ,QNE9
	99101-ZH8-0920	JET, MAIN, #92 (CARBURETOR NO.)	(1)	-	-	-----	QNE9/A
	99101-ZH8-0950	JET, MAIN, #95 (CARBURETOR NO.)	(1)	-	-	BE80A B	----- HAQ,QAQ,QNE9
			1	-	-	-----	EDK,VXK
			(1)	-	-	-----	QNE9/A
	99101-ZH8-0980	JET, MAIN, #98 (CARBURETOR NO.)	(1)	-	-	BE80A B	----- HAQ,QAQ,QNE9
			1	-	-	-----	QNE9/A
	99101-ZH8-0900	JET, MAIN, #90 (CARBURETOR NO.)	(1)	-	-	BE80A B	----- HAQ,QAQ,QNE9
			(1)	-	-	-----	ED9/A
	99101-ZH8-0920	JET, MAIN, #92 (CARBURETOR NO.)	(1)	-	-	-----	ED9/A
			(1)	-	-	BE34C B	----- ED9,EN,ES,ET,ETS,ETX,VA,VAA,VA AE,VE,VHE,VNG,VNG1,VNG2,VXA,VXG
			(1)	-	-	BE34C B	BE34C B EDN5,ED7,ED8,ES1,VD16,VEB6,VH,VMX,VX,VXB,VXE,VXEB,VXE4,VXE8,VXQ4
				-	-	-----	VXU,VXU1,VX16,VX8
	99101-ZH8-0950	JET, MAIN, #95 (CARBURETOR NO.)	1	-	-	-----	EDK,ED9/A,VSH7,VXK
			1	-	-	BE34C B	----- ED9,EN,ES,ET,ETS,ETX,VA,VAA,VA AE,VE,VHE,VNG,VNG1,VNG2,VXA,VXG
			1	-	-	BE34C B	BE34C B EDN5,ED7,ED8,ES1,VD16,VEB6,VH,VMX,VX,VXB,VXE,VXEB,VXE4,VXE8,VXQ4
				-	-	-----	VXU,VXU1,VX16,VX8



Ref. No.	Part No.	Description	Reqd. QTY			Serial No.	Parts catalogue code	
			(1)	(2)	(3)			
36)	99101-ZH8-0900	JET, MAIN, #90 (CARBURETOR NO.)	(1)	-	-	EDN5/A, ED8/A, ES1/A, VAD2/A, VA2/A, VDE2/A, VH12/A, VH22/A, VSH7, VWE2/A, VW12/A, VX/A, VXB/A, VXB7/A, VX8/A, VXE/A, VXE8/A, VXE2/A, VXE7, VXE7/A, VXQ4/A, VXU/A, VXU1/A, VX8/A		
			(1)	-	-	BE80D B	EDN5, ED7, ED8, ES1, VAD2, VA2, VDE2, VH, VH12, VH22, VMX, VWA2, VWE2, VW12, VV, VXB, VXB2, VXE, VXE8, VXE2, VXE4, VXE6, VXE8, VXQ4, VXU, VXU1, VX8	
	99101-ZH8-0920	JET, MAIN, #92 (CARBURETOR NO.)	(1)	-	-	BE80D B	EDN5/A, ED8/A, ES1/A, VAD2/A, VA2/A, VDE2/A, VH12/A, VH22/A, VSH7, VWE2/A, VW12/A, VX/A, VXB/A, VXB7/A, VXE/A, VXE8/A, VXE2/A, VXE7, VXE7/A, VXQ4/A, VXU/A, VXU1/A, VX8/A	
			(1)	-	-	BE80D B	EDN5, ED7, ED8, ES1, VAD2, VA2, VDE2, VH, VH12, VH22, VMX, VWA2, VWE2, VW12, VV, VXB, VXB2, VXE, VXE8, VXE2, VXE4, VXE6, VXE8, VXQ4, VXU, VXU1, VX8	
	99101-ZH8-0950	JET, MAIN, #95 (CARBURETOR NO.)	1	-	-	BE80D B	EDN5/A, ED8/A, ES1/A, VAD2/A, VA2/A, VDE2/A, VH12/A, VH22/A, VSH7, VWE2/A, VW12/A, VX/A, VXB/A, VXB7/A, VXE/A, VXE8/A, VXE2/A, VXE7, VXE7/A, VXQ4/A, VXU/A, VXU1/A, VX8/A	
			1	-	-	BE80D B	EDN5, ED7, ED8, ES1, VAD2, VA2, VDE2, VH, VH12, VH22, VMX, VWA2, VWE2, VW12, VV, VXB, VXB2, VXE, VXE8, VXE2, VXE4, VXE6, VXE8, VXQ4, VXU, VXU1, VX8	
	99101-ZH7-0880	JET, MAIN, #88 (CARBURETOR NO.)	(1)	-	-	BE80B A	EDN5/A, ED8/A, ES1/A, VAD2/A, VA2/A, VDE2/A, VH12/A, VH22/A, VSH7, VWE2/A, VW12/A, VX/A, VXB/A, VXB7/A, VXE/A, VXE8/A, VXE2/A, VXE7, VXE7/A, VXQ4/A, VXU/A, VXU1/A, VX8/A	
			(1)	-	-	BE80B A	EDN5, ED7, ED8, ES1, VAD2, VA2, VDE2, VH, VH12, VH22, VMX, VWA2, VWE2, VW12, VV, VXB, VXB2, VXE, VXE8, VXE2, VXE4, VXE6, VXE8, VXQ4, VXU, VXU1, VX8	
	99101-ZH7-0900	JET, MAIN, #90 (CARBURETOR NO.)	(1)	-	-	BE80B A	HA2, HX2, HX26, LX2, LX26, PKT2, QAE2, QAE6, QAP2, QA2, QA26, QH2, QMT2, QNE2, QNE6, QNR2, QNR6, QPE2, QTC2, QXE2, QXE6, QX2, SME2, SMX2, SXE2, VAD2, VA2, VDE2, VH12, VH22, VWA2, VWC2, VWE2, VWS2, VW12, VXB2, VXE2, VXE6	
	99101-ZH7-0920	JET, MAIN, #92 (CARBURETOR NO.)	1	-	-	BE80B A	HA2, HX2, HX26, LX2, LX26, PKT2, QAE2, QAE6, QAP2, QA2, QA26, QH2, QMT2, QNE2, QNE6, QNR2, QNR6, QPE2, QTC2, QXE2, QXE6, QX2, SME2, SMX2, SXE2, VAD2, VA2, VDE2, VH12, VH22, VWA2, VWC2, VWE2, VWS2, VW12, VXB2, VXE2, VXE6	
	99101-ZH8-0880	JET, MAIN, #88 (CARBURETOR NO.)	(1)	-	-	BE80B B	HA2, HX2, HX26, LH, LHB3, LHE, LHQ4, LJ, LJG, LKE, LX, LXE, LXE2, LXE4, LXE6, LXQ4, LXU, LX2, LX26, PKT2, PKX4, PX, QAE2, QAE6, QAP2, QA2, QA26, QE, QH, QHB3, QHE, QHP1, QHQ4, QH2, QMEO, QMH, QMT2, QNE2, QNE6, QNR2, QNR6, QN18, QPE2, QTC2, QX, QXB, QXE, QXE2, QXE4, QXE6, QXE8, QXQ4, QXU, QX2, SDE, SE, SH, SHB1, SHB3, SHE, SHQ4, SJ, SJG, SKE, SKZ, SMEO, SME2, SMX2, STP, STQ, STR, SX, SXB, SXE, SXEB, SXE2, SXE4, SXE8, SXQ4, SXU, VD16, VEB6, VWC2, VWS2, VX16	
			(1)	-	-	BE80B B	VAD2, VA2, VDE2, VH12, VH22, VWA2, VWE2, VW12, VXB2, VXE2, VXE6	

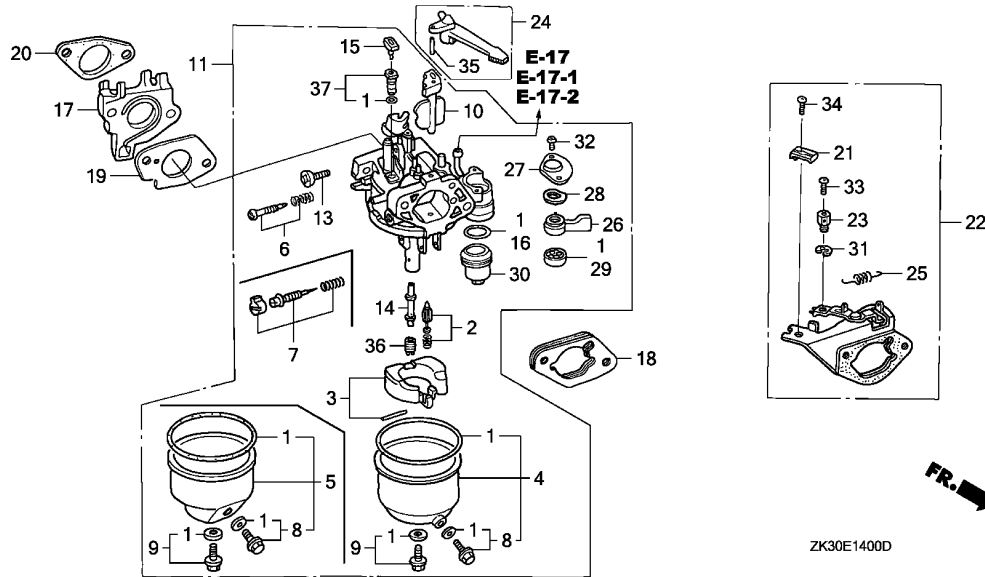

2

Ref. No.	Part No.	Description	Reqd. QTY			Serial No.	Parts catalogue code
			GX	340K1	(3)		
36)	99101-ZH8-0900	JET, MAIN, #90 .....	(1)	-	-	-----	EDK,ES2,HA2/A,HX26/A,LH/A,LHB3/A,LHB5,LHE/A,LHQ4/A,LJ/A,LJG/A,LJS LJS/A,LJS1,LKE/A,LWD,LX/A,LXE/A,LXE2/A,LXE4/A,LXE8/A,LXQ4/A,LXU/A LX2/A,LX26/A,PKT2/A,PKT4,PKT4/A,PKX2,PKX4/A,PX/A,PXA2,QAB2,QAB2/A QAC2,QAC2/A,QAE2/A,QAE6/A,QAG,QAG/A,QA2,QA2/A,QAP2/A,QA2/A QA26/A,QE/A,QH/A,QHB3/A,QHB5,QHE/A,QHP1/A,QHQ4/A,QL2,QMEO/A,QMH/A QMT2/A,QMX2,QNE2/A,QNR2/A,QNR6/A,QTC2/A,QX/A,QXB/A,QXB7,QXB7/A QXE/A,QXE4/A,QXE6/A,QXE8/A,QXQ4/A,QXU/A,SE/A,SH/A,SHB3/A,SHQ4/A SJ/A,SJG/A,SKE/A,SKZ/A,SME0/A,SMX2/A,STP/A,STQ/A,STR/A,SX/A,SXB/A SXB7,SXB7/A,SXE/A,SXEB/A,SXE4/A,SXE8/A,SXQ4/A,SXU/A,VWC2/A,VVS2/A VXX,VX16/A
		(CARBURETOR NO.)	(1)	-	-	BE80B B -----	HA2,HX2,HX26,LH,LHB3,LHE,LHQ4,LJ,LJG,LKE,LX,LXE,LXE2,LXE4,LXE6 LXE8,LXQ4,LXU,LX2,LX26,PKT2,PKX4,PX,QAE2,QAE6,QAP2,QA2,QA26,QE,QH QHB3,QHE,QHP1,QHQ4,QH2,QMEO,QMH,QMT2,QNE2,QNE6,QNR2,QNR6,QN18 QPE2,QTC2,QX,QXB,QXE,QXE2,QXE4,QXE6,QXE8,QXQ4,QXU,QX2,SDE,SE,SH SHB1,SHB3,SHE,SHQ4,SJ,SJG,SKE,SKZ,SME0,SME2,SMX2,STP,STQ,STR,SX SXB,SXE,SXEB,SXE2,SXE4,SXE8,SXQ4,SXU,VD16,VEB6,VWC2,VVS2,VX16
		..	(1)	-	-	BE80B B BE80B B	VAD2,VA2,VDE2,VH12,VH22,VWA2,VWE2,VW12,VXB2,VXE2,VXE6

Ref. No.	Part No.	Description	Reqd. QTY			Serial No.	Parts catalogue code
			(1)	(2)	(3)		
36)	99101-ZH8-0920	JET, MAIN, #92	1	-	-	HA2/A, HX26/A, LH/A, LHB3/A, LHB5, LHE/A, LHQ4/A, LJ/A, LJG/A, LJS, LJS/A, LJS1, LKE/A, LWD, LX/A, LXE/A, LXE2/A, LXE4/A, LXE8/A, LXQ4/A, LXU/A, LX2/A, LX26/A, PKT2/A, PKT4, PKT4/A, PKX2, PKX4/A, PX/A, PXA2, QAB2, QAB2/A, QAC2, QAC2/A, QAE2/A, QAE6/A, QAG, QAG/A, QAH2, QAH2/A, QAP2/A, QA2/A, QA26/A, QE/A, QH/A, QHB3/A, QHB5, QHE/A, QHP1/A, QHQ4/A, QL2, QMEO/A, QMH/A, QMT2/A, QMX2, QNE2/A, QNR2/A, QNR6/A, QTC2/A, QX/A, QXB/A, QXB7, QXB7/A, QXE/A, QXE4/A, QXE6/A, QXE8/A, QXQ4/A, QXU/A, SE/A, SH/A, SHB3/A, SHQ4/A, SJ/A, SJG/A, SKE/A, SKZ/A, SMEO/A, SMX2/A, STP/A, STQ/A, STR/A, SX/A, SXB/A, SXB7, SXB7/A, SXE/A, SXEB/A, SXE4/A, SXE8/A, SXQ4/A, SXU/A, VWC2/A, VWS2/A, VX16/A	
	(CARBURETOR NO.)		1	-	-	BE80B B	HA2, HX2, HX26, LH, LHB3, LHE, LHQ4, LJ, LJG, LKE, LX, LXE, LXE2, LXE4, LXE6, LXE8, LXQ4, LXU, LX2, LX26, PKT2, PKX4, PX, QAE2, QAE6, QAP2, QA2, QA26, QE, QH, QHB3, QHE, QHP1, QHQ4, QH2, QMEO, QMH, QMT2, QNE2, QNE6, QNR2, QNR6, QN18, QPE2, QTC2, QX, QXB, QXE, QXE2, QXE4, QXE6, QXE8, QXQ4, QXU, QX2, SDE, SE, SH, SHB1, SHB3, SHE, SHQ4, SJ, SJG, SKE, SKZ, SMEO, SME2, SMX2, STP, STQ, STR, SX, SXB, SXE, SXEB, SXE2, SXE4, SXE8, SXQ4, SXU, VD16, VEB6, VWC2, VWS2, VX16
	“		1	-	-	BE80B B	VAD2, VA2, VDE2, VH12, VH22, VWA2, VWE2, VW12, VXB2, VXE2, VXE6
	99101-ZH7-0950	JET, MAIN, #95	(1)	-	-	EDK, ES2, VXX	EDK, ES2, VXX
	(CARBURETOR NO.)		(1)	-	-	BE80C A	QDW9, QXC6, QXC9
	99101-ZH7-0980	JET, MAIN, #98	(1)	-	-	BE80C A	QDW9, QXC6, QXC9
	(CARBURETOR NO.)		(1)	-	-	BE80C A	QDW9, QXC6, QXC9
	99101-ZH7-1000	JET, MAIN, #100	1	-	-	BE80C A	QDW9, QXC6, QXC9
	(CARBURETOR NO.)		(1)	-	-	EDK, VXX	EDK, VXX
	99101-ZH8-0950	JET, MAIN, #95	(1)	-	-	BE80C B	ENT2, QDW9/A, QWH2, QWH2/A, QXC/A, QXC6/A, QXC9/A
	(CARBURETOR NO.)		(1)	-	-	BE80C B	QDW9, QXC, QXC6, QXC9
	99101-ZH8-0980	JET, MAIN, #98	(1)	-	-	BE80C B	ENT2, QDW9/A, QWH2, QWH2/A, QXC/A, QXC6/A, QXC9/A
	(CARBURETOR NO.)		(1)	-	-	BE80C B	QDW9, QXC, QXC6, QXC9
	99101-ZH8-1000	JET, MAIN, #100	1	-	-	BE80C B	ENT2, QDW9/A, QWH2, QWH2/A, QXC/A, QXC6/A, QXC9/A
	(CARBURETOR NO.)		1	-	-	BE80C B	QDW9, QXC, QXC6, QXC9
	99101-ZH7-0920	JET, MAIN, #92	1	-	-	BE21C A	LP
	(CARBURETOR NO.)		1	-	-	BE21C B	LP
	99101-ZH8-0920	JET, MAIN, #92	1	-	-	BE21C B	LP
	(CARBURETOR NO.)		1	-	-	BE47A B	QXC
37	99204-ZA0-0400	JET SET, PILOT, #40	1	-	-	BE47A B	QXC
	(CARBURETOR NO.)		1	-	-	BE47A B	QXC
	99204-ZA0-0450	JET SET, PILOT, #45	-	(1)	-		L1/A, P1/A, Q1/A, S1/A
	(CARBURETOR NO.)		-	(1)	-	BE34B C	L1, P1, Q1, S1



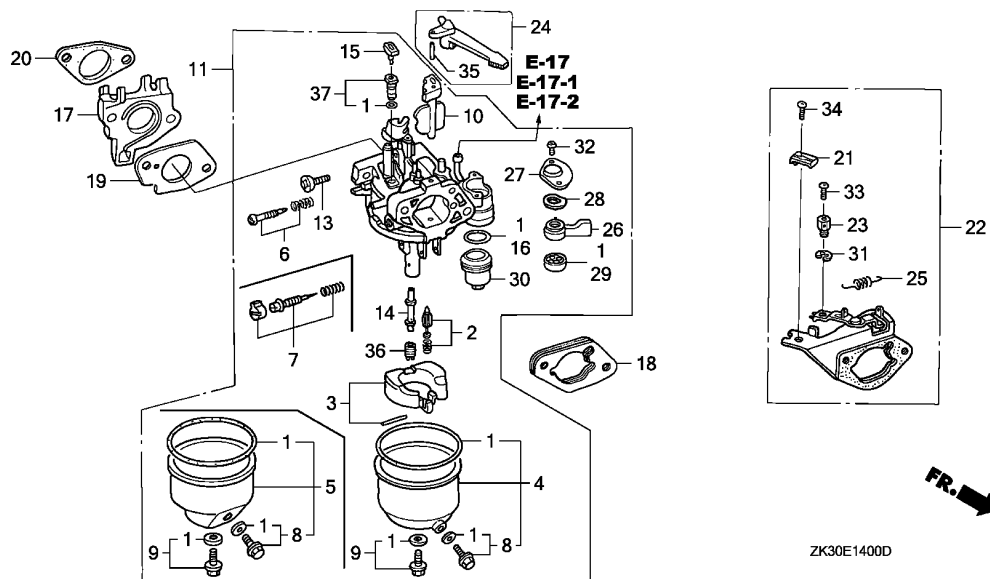

Ref. No.	Part No.	Description	Reqd. QTY			Serial No.	Parts catalogue code
			GX	340K1			
			(1)	(2)	(3)		
37)	99204-ZE0-0350	JET SET, PILOT, #35 .....	1	-	-	-----	EDN5/A, ED8/A, ES1/A, ES2, HAQ, HA2, HA2/A, HX2, HX26, HX26/A, LH/A, LHB3/A, LHB5, LHE/A, LHQ4/A, LJ/A, LJG/A, LJS, LJS/A, LJS1, LKE/A, LWD, LX/A, LXE/A, LXE2, LXE2/A, LXE4/A, LXE6, LXE8/A, LXQ4/A, LXU/A, LX2, LX2/A, LX26, LX26/A, PKT2, PKT2/A, PKT4, PKT4/A, PKX2, PKX4/A, PX/A, PXA2, QAB2, QAB2/A, QAC2, QAC2/A, QAE2, QAE2/A, QAE6, QAE6/A, QAG, QAG/A, QAH2, QAH2/A, QAP2, QAP2/A, QAQ, QA2, QA2/A, QA26, QA26/A, QDW9, QDW9/A, QE/A, QH/A, QHB3/A, QHB5, QHE/A, QHP1/A, QHQ4/A, QH2, QL2, QMEO/A, QMH/A, QMT2, QMT2/A, QMX2, QNE2, QNE2/A, QNE6, QNE9, QNE9/A, QNR2, QNR2/A, QNR6, QNR6/A, QPE2, QTC2, QTC2/A, QWH2, QWH2/A, QX/A, QXB/A, QXB7, QXB7/A, QXC/A, QXC6, QXC6/A, QXC9, QXC9/A, QXE/A, QXE2, QXE4/A, QXE6, QXE6/A, QXE8/A, QXQ4/A, QXU/A, QX2, SE/A, SH/A, SHB3/A, SHQ4/A, SJ/A, SJG/A, SKE/A, SKZ/A, SMEO/A, SME2, SMX2, SMX2/A, STP/A, STQ/A, STR/A, SX/A, SXB/A, SXB7, SXB7/A, SXE/A, SXEB/A, SXE2, SXE4/A, SXE8/A, SXQ4/A, SXU/A, VAD2, VAD2/A, VA2, VA2/A, VDE2, VDE2/A, VH12, VH12/A, VH22, VH22/A, VSH7, VWA2, VWC2, VWC2/A, VWE2, VWE2/A, VWS2, VWS2/A, VW12, VW12/A, VX/A, VXB/A, VXB2, VXB7, VXB7/A, VXE/A, VXEB/A, VXE2, VXE2/A, VXE6, VXE7, VXE7/A, VXE8/A, VXX, VXQ4/A, VXU/A, VXU1/A, VX16/A, VX8/A
		(CARBURETOR NO.)	1	-	-	BE80B B -----	LH, LHB3, LHE, LHQ4, LJ, LJG, LKE, LX, LXE, LXE4, LXE8, LXQ4, LXU, PKX4, PX, QE, QH, QHB3, QHE, QHP1, QHQ4, QMEO, QMH, QN18, QX, QXE, QXE4, QXE8, QXQ4, QXU, SDE, SE, SH, SHB1, SHB3, SHE, SHQ4, SJ, SJG, SKE, SKZ, SMEO, STP, STQ, STR, SX, SXE, SXE4, SXE8, SXQ4, SXU, VD16, VEB6, VX16
		//	1	-	-	BE80C B -----	QXC
		//	1	-	-	BE80D B -----	EDN5, ED7, ED8, ES1, QXB, SXB, SXEB, VH, VMX, VX, VXB, VXE, VXEB, VXE4, VXE8, VXQ4, VXU, VXU1, VX8

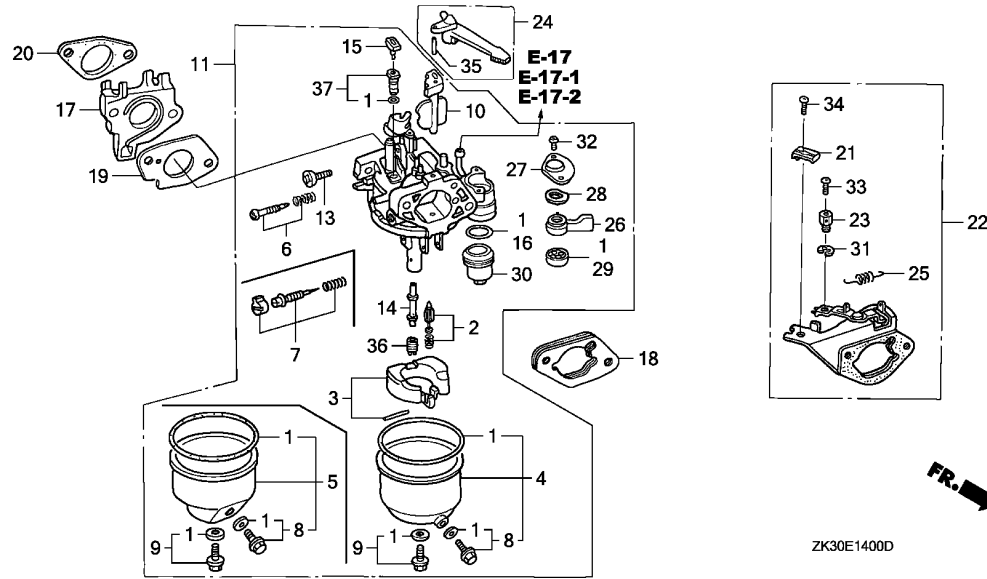

Ref. No.	Part No.	Description	Reqd. QTY			Serial No.	Parts catalogue code
			GX	340K1			
			(1)	(2)	(3)		
37)	99204-ZE0-0450	JET SET, PILOT, #45	1	(1)	-	-----	BJ,EDK,ED9,ED9/A,EN,ES,ET,ETS,ETX,HA,HH,HX,LHB1,LHW,LSX,LT,LT/A,LXZ,PXE8,PXE8/A,QA,QAE,QAP,QAPE,QKA4,QKA4/A,QME8,QME8/A,QNE,QP,QP/A,QT,QT/A,QXEB,SHEZ,STJ,STJ/A,SWX,SWX/A,SXP,VA,VAA,VAAE,VAH1,VAH2,VAW1,VDE,VE,VHE,VNG,VNG1,VNG2,VWA,VXA,VXG,V1,YJ
		(CARBURETOR NO.)	1	-	-	-----	BE34B C LH,LHB3,LHE,LHQ4,LJ,LJG,LKE,LX,LXE,LXE4,LXE8,LXQ4,LXU,PKX4,PX,QE,QH,QHB3,QHE,QHP1,QHQ4,QMEO,QMH,QN18,QX,QXB,QXE,QXE4,QXE8,QXQ4,QXU,SDE,SE,SH,SHB1,SHB3,SHE,SHQ4,SJ,SJG,SKE,SKZ,SMEO,STP,STQ,STR,SX,SXB,SXE,SXEB,SXE4,SXE8,SXQ4,SXU
		//	1	-	-	-----	BE34C B EDN5,ED7,ED8,ES1,VD16,VEB6,VH,VMX,VX,VXB,VXE,VXEB,VXE4,VXE8,VXQ4,VXU,VXU1,VX16,VX8
	99204-ZE2-0400	JET SET, PILOT, #40	-	(1)	-	-----	BE34B B L1,P1,Q1,S1
		//	1	-	-	-----	LP



# E-14-1

# CARBURETOR(2)

**M 4**

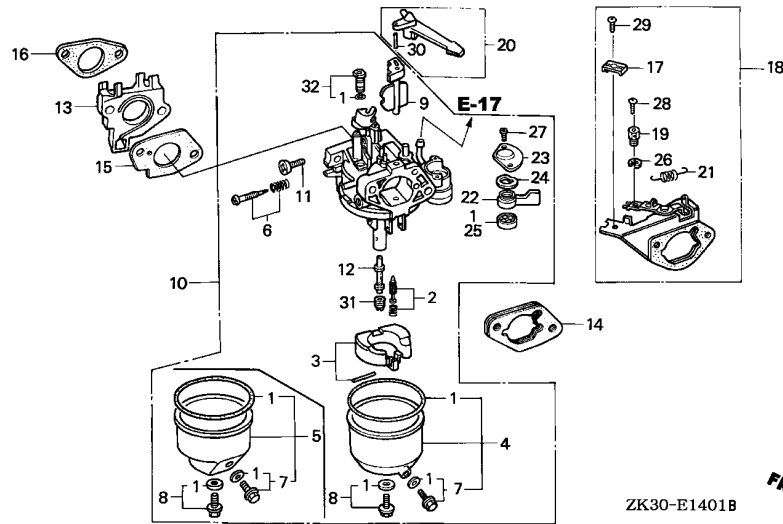

ZK30-E1401B **FR.**

Ref. No.	L.O.N.	(Relative ref. Number) Description	F.R.T.
1	3111B1	GASKET SET, CARBURETOR (3)	0.3
2	3111E1	VALVE SET, FLOAT AND/OR FLOAT SET (5)	0.3
4	3111A3	CHAMBER SET, FLOAT AND/OR GASKET, FLOAT CHAMBER	0.2
6	3111D7	SCREW SET, PILOT	0.2
10	3111F3	CARBURETOR (16)	0.2
13	3111C0	INSULATOR, CARBURETOR AND/OR PACKING, INSULATOR	0.2
14	3111D9	SPACER, CARBURETOR	0.2
15	3111C8	PACKING, CARBURETOR	0.2
18	3111G3	STAY, CHOKE CONTROL	0.2
20	8101F9	LEVER, CARBURETOR CHOKE	0.2
21	3111M8	SPRING, CHOKE CONTROL STAY RETURN (22,23,24)	0.1
25	3101C5	PACKING, FUEL COCK	0.2
31	3111C3	JET, MAIN	0.3

Ref. No.	Part No.	Description	Reqd. QTY			Serial No.	Parts catalogue code
			GX	340K1			
			(1)	(2)	(3)		
1	16010-ZE2-015	GASKET SET (EXCEPT 16173-001-004)	-	(1)	-		
2	16011-ZA0-931	VALVE SET, FLOAT	-	(1)	-		
3	16013-ZA0-931	FLOAT SET	-	(1)	-		
4	16015-ZE2-005	CHAMBER SET, FLOAT (CARBURETOR NO.)	-	(1)	-	BE34A A	L1,P1,Q1,S1,V1
5	16015-ZE8-005	CHAMBER SET, FLOAT (CARBURETOR NO.)	-	(1)	-	BE34A B	L1/A,P1/A,Q1/A,S1/A
6	16016-ZE0-005	SCREW SET, PILOT	-	(1)	-		
7	16024-ZE1-811	SCREW SET, DRAIN	-	(1)	-		
8	16028-ZE0-005	SCREW SET	-	(1)	-		
9	16044-ZE3-W20	CHOKE SET	-	(1)	-		
10	16100-ZE3-W20	CARBURETOR ASSY. (BE34A A)	-	(1)	-	2519532	L1
			-	(1)	-	2521889	P1,Q1,S1,V1
	16100-ZE3-W21	CARBURETOR ASSY. (BE34A B)	-	(1)	-		L1/A,P1/A,Q1/A,S1/A
			-	(1)	-	2519533	L1
			-	(1)	-	2521890	P1,Q1,S1,V1
11	16124-ZE0-005	SCREW, THROTTLE STOP	-	(1)	-		
12	16166-ZE3-W20	NOZZLE, MAIN	-	(1)	-		
13	16211-ZF6-000	INSULATOR, CARBURETOR	-	(1)	-		
14	16220-ZA0-702	SPACER COMP., CARBURETOR	-	(1)	-		
15	16221-ZF6-000	PACKING, CARBURETOR	-	(1)	-	2178372	L1,P1,Q1,S1,V1
	16221-ZF6-800		-	(1)	-		L1/A,P1/A,Q1/A,S1/A
			-	(1)	-	2178373	L1,P1,Q1,S1,V1
16	16223-ZF6-000	PACKING, INSULATOR	-	(1)	-	2178372	L1,P1,Q1,S1,V1

**2**

E-14-1

CARBURETOR(2)

M 5

Ref. No.	Part No.	Description	Reqd. QTY			Serial No.	Parts catalogue code
			(1)	(2)	(3)		
16)	16223-ZE3-W00	PACKING, INSULATOR .....	-	(1)	-	-----	L1/A,P1/A,Q1/A,S1/A
17	16576-891-000	HOLDER, CABLE .....	-	(1)	-	2178373	----- L1,P1,Q1,S1,V1
18	16590-ZE2-812	STAY ASSY., CHOKE CONTROL (REMOTE)	-	(1)	-		
19	16594-883-010	HOLDER, WIRE .....	-	(1)	-		
20	16610-ZE1-000	LEVER COMP., CHOKE (STD.) ...	-	(1)	-		
21	16615-ZE2-810	SPRING, RETURN .....	-	(1)	-		
22	16953-ZE1-811	LEVER, COCK .....	-	(1)	-		
	16953-ZE1-812	(CARBURETOR NO.) .....	-	(1)	-	----- BE34A A	L1,P1,Q1,S1,V1
		(CARBURETOR NO.) .....	-	(1)	-	-----	L1/A,P1/A,Q1/A,S1/A
23	16954-ZE1-811	PLATE, LEVER SETTING .....	-	(1)	-	----- BE34A B	L1,P1,Q1,S1,V1
	16954-ZE1-812	(CARBURETOR NO.) .....	-	(1)	-	-----	L1/A,P1/A,Q1/A,S1/A
		(CARBURETOR NO.) .....	-	(1)	-	----- BE34A B	L1,P1,Q1,S1,V1
24	16956-ZE1-811	SPRING, COCK LEVER .....	-	(1)	-		
25	16957-ZE1-812	PACKING, FUEL COCK .....	-	(1)	-		
26	90605-230-000	CIRCLIP, 5MM .....	-	(1)	-		
27	93500-03008-1G	SCREW, PAN, 3X8 .....	-	(2)	-	----- BE34A A	L1,P1,Q1,S1,V1
	93500-03006-1H	(CARBURETOR NO.) .....	-	(2)	-	-----	L1/A,P1/A,Q1/A,S1/A
		(CARBURETOR NO.) .....	-	(2)	-	----- BE34A B	L1,P1,Q1,S1,V1
28	93500-04006-0H	SCREW, PAN, 4X6 .....	-	(1)	-		
29	93893-05016-00	SCREW-WASHER, 5X16 .....	-	(1)	-		
30	94305-20122	PIN, SPRING, 2X12 .....	-	(1)	-		
31	99101-ZF5-0920	JET, MAIN, #92 .....	-	(1)	-	----- BE34A A	L1,P1,Q1,S1,V1
	99101-ZF5-0950	(CARBURETOR NO.) .....	-	(1)	-	-----	L1/A,P1/A,Q1/A,S1/A
	99101-ZF5-0980	JET, MAIN, #95 .....	-	(1)	-	----- BE34A A	L1,P1,Q1,S1,V1
		(CARBURETOR NO.) .....	-	(1)	-	-----	L1/A,P1/A,Q1/A,S1/A
	99101-ZH8-0920	JET, MAIN, #98 .....	-	(1)	-	----- BE34A A	L1,P1,Q1,S1,V1
		(CARBURETOR NO.) .....	-	(1)	-	-----	L1/A,P1/A,Q1/A,S1/A
	99101-ZH8-0950	JET, MAIN, #92 .....	-	(1)	-	----- BE34A B	L1,P1,Q1,S1,V1
		(CARBURETOR NO.) .....	-	(1)	-	-----	L1/A,P1/A,Q1/A,S1/A
	99101-ZH8-0980	JET, MAIN, #95 .....	-	(1)	-	----- BE34A B	L1,P1,Q1,S1,V1
		(CARBURETOR NO.) .....	-	(1)	-	-----	L1/A,P1/A,Q1/A,S1/A
32	99204-ZE0-0450	JET SET, PILOT, #45 .....	-	(1)	-	----- BE34A A	L1,P1,Q1,S1,V1
	99204-ZA0-0450	(CARBURETOR NO.) .....	-	(1)	-	-----	L1/A,P1/A,Q1/A,S1/A
		(CARBURETOR NO.) .....	-	(1)	-	----- BE34A B	L1,P1,Q1,S1,V1

2

# E-14-2

# CARBURETOR(3)

M 6

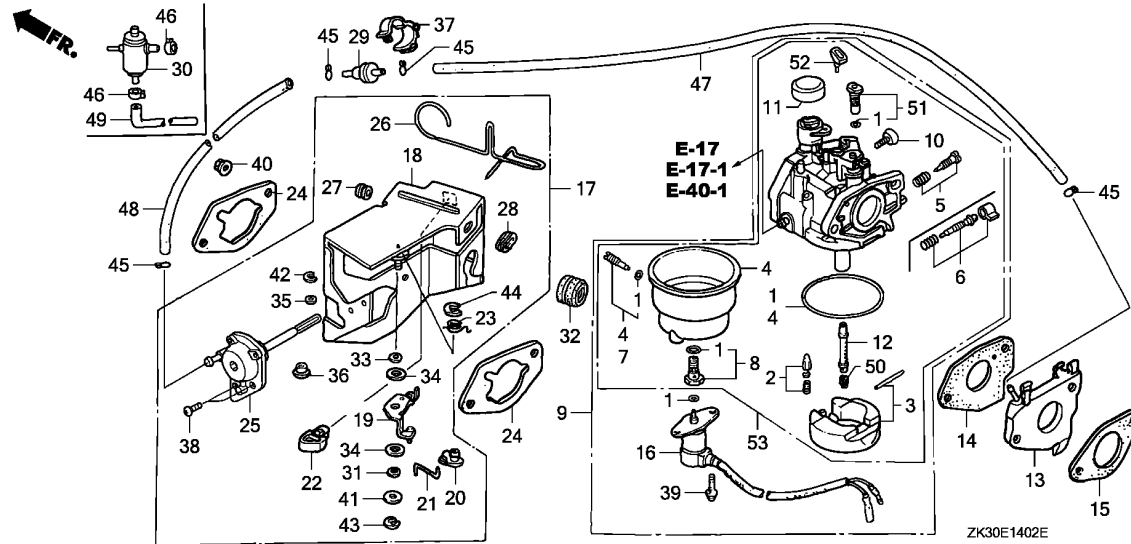

Ref. No.	L.O.N.	(Relative ref. Number) Description	F.R.T.
1	3111G1	GASKET SET, CARBURETOR(A) (3)	0.4
2	3111G6	VALVE SET, FLOAT AND/OR FLOAT SET(A)	0.4
4	3111M2	CHAMBER SET, FLOAT AND/OR GASKET, FLOAT CHAMBER(A) (6)	0.3
5	3111D7	SCREW SET, PILOT	0.2
9	3111G7	CARBURETOR(A) (15)	0.3
13	3111G2	INSULATOR, CARBURETOR AND/OR PACKING, INSULATOR(A)	0.3
14	3111G5	PACKING, CARBURETOR(A)	0.3
16	6211C0	VALVE, CARBURETOR SOLENOID	0.2
17	8101R1	STAY, MANUAL CHOKE (20)	0.3
21	8101J8	ROD, CARBURETOR CHOKE	0.2
24	3121H2	PACKING, AIR CLEANER(A)	0.3
25	3111A7	DIAPHRAGM, CARBURETOR	0.3
29	311175	VALVE, DASHPOT CHECK	0.1
50	3111G4	JET, MAIN(A)	0.4

Ref. No.	Part No.	Description	Reqd. QTY			Serial No.	Parts catalogue code
			GX 340K1	(1)	(2)		
1	16010-ZE3-701	GASKET SET	1	-	-	-----	EDE2,EDE2/A,EDN,EDN2,EDN2/A,EDS,EDS1,EDS1/A,EDS2,EDS2/A,EDS3,EDS4,EDS6,EDS6/A,EDT,EDT/A,EDT1,EDT1/A,EDT2,EDT3,EDT6,EDT6/A,ED6,ED6/A,EMT,EMT/A,ENT,ENT/A,ENT2,EN6,EN6/A,ES3,ES3/A,ES4,ES4/A,VMQ,VMT,VMT/A,VS2,VS3,VS4,VS5,VS6,VS7,VTE2,VWE
	16010-ZA0-921	(CARBURETOR NO.)	1	-	-	-----	BE82B B VC2
	16010-ZA0-921	(CARBURETOR NO.)	1	-	-	-----	VC2/A,VWC
2	16011-ZA0-931	VALVE SET, FLOAT	1	-	-	-----	VC2
3	16013-ZA0-931	FLOAT SET	1	-	-	-----	EDE2,EDE2/A,EDN,EDN2,EDN2/A,EDS,EDS1,EDS1/A,EDS2,EDS2/A,EDS3,EDS4,EDS6,EDS6/A,EDT,EDT/A,EDT1,EDT1/A,EDT2,EDT3,EDT6,EDT6/A,ED6,ED6/A,EMT,EMT/A,ENT,ENT/A,ENT2,EN6,EN6/A,ES3,ES3/A,ES4,ES4/A,VC2,VC2/A,VMQ,VMT,VMT/A,VS2,VS3,VS4,VS5,VS6,VS7,VTE2,VWC,VWE
4	16015-ZA0-931	CHAMBER SET, FLOAT	1	-	-	-----	EDE2,EDE2/A,EDN,EDN2,EDN2/A,EDS,EDS1,EDS1/A,EDS2,EDS2/A,EDS3,EDS4,EDS6,EDS6/A,EDT,EDT/A,EDT1,EDT1/A,EDT2,EDT3,EDT6,EDT6/A,ED6,ED6/A,EMT,EMT/A,ENT,ENT/A,ENT2,EN6,EN6/A,ES3,ES3/A,ES4,ES4/A,VC2,VC2/A,VMQ,VMT,VMT/A,VS2,VS3,VS4,VS5,VS6,VS7,VTE2,VWC,VWE
5	16016-ZE0-005	SCREW SET, PILOT (CARBURETOR NO.)	1	-	-	-----	BE37B B ED6
	16016-ZE0-005	SCREW SET, PILOT (CARBURETOR NO.)	1	-	-	-----	BE37B C EDN,EDS,EDS1,EDS3,EDT1,ES3,ES4,VMT
6	16016-ZH7-W01	SCREW SET, PILOT (CARBURETOR NO.)	1	-	-	-----	EDE2,EDE2/A,EDN2,EDN2/A,EDS1/A,EDS2,EDS2/A,EDS4,EDS6,EDS6/A,EDT,EDT/A,EDT1/A,EDT2,EDT3,EDT6,EDT6/A,ED6/A,EMT,EMT/A,ENT,ENT/A,ENT2,EN6,EN6/A,ES3/A,ES4/A,VC2,VC2/A,VMQ,VMT/A,VS2,VS3,VS4,VS5,VS6,VS7,VTE2,VWC,VWE
	16016-ZH7-W01	SCREW SET, PILOT (CARBURETOR NO.)	1	-	-	-----	EDN,EDS,EDS1,EDS3,EDT1,ED6,ES3,ES4,VMT



Ref. No.	Part No.	Description	Reqd. QTY			Serial No.	Parts catalogue code
			(1)	(2)	(3)		
7	16024-124-761	SCREW SET, DRAIN .....	1	-	-	-----	EDE2,EDE2/A,EDN,EDN2,EDN2/A,EDS,EDS1,EDS2,EDS2/A,EDS3,EDS6,EDS6/A,EDT,EDT/A,EDT1,EDT2,EDT6,EDT6/A,ED6,ED6/A,EMT,ENT,ENT/A,ENT2,EN6,EN6/A,ES3,ES4,VC2,VC2/A,VMT,VTE2,VWC,VWE
		(CARBURETOR NO.) .....	1	-	-	-----	BE82B B EDS1/A,EDT1/A,EMT/A,ES3/A,ES4/A,VMQ,VMT/A,VS3,VS5
	16024-124-760	.....	1	-	-	-----	EDS4,EDT3,VS2,VS4,VS6,VS7
		(CARBURETOR NO.) .....	1	-	-	-----	BE82M A EDS1/A,EDT1/A,EMT/A,ES3/A,ES4/A,VMQ,VMT/A,VS3,VS5
8	16028-ZA0-931	SCREW SET .....	1	-	-	-----	EDE2,EDE2/A,EDN,EDN2,EDN2/A,EDS,EDS1,EDS1/A,EDS2,EDS2/A,EDS3,EDS4,EDS6,EDS6/A,EDT,EDT/A,EDT1,EDT1/A,EDT2,EDT3,EDT6,EDT6/A,ED6,ED6/A,EMT,EMT/A,ENT,ENT/A,ENT2,EN6,EN6/A,ES3,ES3/A,ES4,ES4/A,VMQ,VMT,VMT/A,VS2,VS3,VS4,VS5,VS6,VS7,VTE2,VWE
		(CARBURETOR NO.) .....	1	-	-	-----	BE82B B VC2
	16028-ZA0-701	.....	1	-	-	-----	VC2/A
		(CARBURETOR NO.) .....	1	-	-	-----	VWC
		.....	1	-	-	-----	BE82E A VC2
9	16100-ZE3-D00	CARBURETOR ASSY. (BE37B A) ..	1	-	-	-----	2340658 EDN,EDS,EDS1,EDS3,EDT1,ED6,ES3,ES4
	16100-ZE3-D01	CARBURETOR ASSY. (BE37B B) ..	1	-	-	-----	2374605 ED6
		.....	1	-	-	-----	2340659 2522217 EDN,EDS,EDS1,EDS3,EDT1,ES3,ES4
	16100-ZE3-D02	CARBURETOR ASSY. (BE37B C) ..	1	-	-	-----	3129573 VMT
		.....	1	-	-	-----	2522218 EDN,EDS,EDS1,EDS3,EDT1,ES3,ES4
	16100-ZE3-F10	CARBURETOR ASSY. (BE82B A) ..	1	-	-	-----	2521477 EDE2,EDN2
		.....	1	-	-	-----	2374606 2521477 ED6
	16100-ZE3-F11	CARBURETOR ASSY. (BE82B B) ..	1	-	-	-----	EDS2,EDS6,EDT,EDT2,EDT6,EMT,ENT,EN6,VC2,VTE2
		.....	1	-	-	-----	2521478 EDE2,EDN2,ED6
		.....	1	-	-	-----	3032024 EDN,EDS,EDS1,EDS3,EDT1,ES3,ES4
		.....	1	-	-	-----	3129574 VMT
		.....	1	-	-	-----	4004529 EDS1/A,EDT1/A,EMT/A,ES3/A,ES4/A,VMQ,VMT/A,VS3,VS5
		.....	1	-	-	-----	4004577 EDE2/A,EDN2/A,EDS2/A,EDS6/A,EDT/A,EDT6/A,ED6/A,ENT/A,ENT2,EN6/A,VWE
	16100-ZE3-F12	CARBURETOR ASSY. (BE82B C) ..	1	-	-	-----	4004578 EDE2/A,EDN2/A,EDS2/A,EDS6/A,EDT/A,EDT6/A,ED6/A,ENT/A,ENT2,EN6/A,VWE
	16100-Z5L-F11	CARBURETOR ASSY. (BE82M A/B)	1	-	-	-----	4075028 EDS4,VS4,VS6
		.....	1	-	-	-----	4004530 4075028 EDS1/A,EDT1/A,EMT/A,ES3/A,ES4/A,VMQ,VMT/A,VS3,VS5
	16100-Z5L-F12	CARBURETOR ASSY. (BE82M B) ..	1	-	-	-----	EDT3,VS2,VS7
		.....	1	-	-	-----	4075029 EDS1/A,EDS4,EDT1/A,EMT/A,ES3/A,ES4/A,VMQ,VMT/A,VS3,VS4,VS5,VS6
10	16124-ZE0-005	SCREW, THROTTLE STOP .....	1	-	-	-----	EDE2,EDE2/A,EDN,EDN2,EDN2/A,EDS,EDS1,EDS1/A,EDS2,EDS2/A,EDS3,EDS4,EDS6,EDS6/A,EDT,EDT/A,EDT1,EDT1/A,EDT2,EDT3,EDT6,EDT6/A,ED6,ED6/A,EMT,EMT/A,ENT,ENT/A,ENT2,EN6,EN6/A,ES3,ES3/A,ES4,ES4/A,VC2,VC2/A,VMQ,VMT,VMT/A,VS2,VS3,VS4,VS5,VS6,VS7,VTE2,VWC,VWE
11	16148-141-881	CAP, CHOKE DUST .....	1	-	-	-----	EDE2,EDE2/A,EDN,EDN2,EDN2/A,EDS,EDS1,EDS1/A,EDS2,EDS2/A,EDS3,EDS4,EDS6,EDS6/A,EDT,EDT/A,EDT1,EDT1/A,EDT2,EDT3,EDT6,EDT6/A,ED6,ED6/A,EMT,EMT/A,ENT,ENT/A,ENT2,EN6,EN6/A,ES3,ES3/A,ES4,ES4/A,VC2,VC2/A,VMQ,VMT,VMT/A,VS2,VS3,VS4,VS5,VS6,VS7,VTE2,VWC,VWE
12	16166-ZE3-701	NOZZLE, MAIN .....	1	-	-	-----	BE37B A EDN,EDS,EDS1,EDS3,EDT1,ED6,ES3,ES4
	16166-ZE3-F10	.....	1	-	-	-----	EDE2,EDE2/A,EDN2,EDN2/A,EDS1/A,EDS2,EDS2/A,EDS4,EDS6,EDS6/A,EDT,EDT/A,EDT1/A,EDT2,EDT3,EDT6,EDT6/A,ED6/A,EMT,EMT/A,ENT,ENT/A,ENT2,EN6,EN6/A,ES3/A,ES4/A,VC2,VC2/A,VMQ,VMT,VMT/A,VS2,VS3,VS4,VS5,VS6,VS7,VTE2,VWC,VWE
		(CARBURETOR NO.) .....	1	-	-	-----	BE37B B EDN,EDS,EDS1,EDS3,EDT1,ED6,ES3,ES4
13	16211-ZE3-700	INSULATOR, CARBURETOR .....	1	-	-	-----	EDE2,EDE2/A,EDN,EDN2,EDN2/A,EDS,EDS1,EDS1/A,EDS2,EDS2/A,EDS3,EDS4,EDS6,EDS6/A,EDT,EDT/A,EDT1,EDT1/A,EDT2,EDT3,EDT6,EDT6/A,ED6,ED6/A,EMT,EMT/A,ENT,ENT/A,ENT2,EN6,EN6/A,ES3,ES3/A,ES4,ES4/A,VC2,VC2/A,VMQ,VMT,VMT/A,VS2,VS3,VS4,VS5,VS6,VS7,VTE2,VWC,VWE
14	16221-ZE3-800	PACKING, CARBURETOR .....	1	-	-	-----	EDE2,EDE2/A,EDN,EDN2,EDN2/A,EDS,EDS1,EDS1/A,EDS2,EDS2/A,EDS3,EDS4,EDS6,EDS6/A,EDT,EDT/A,EDT1,EDT1/A,EDT2,EDT3,EDT6,EDT6/A,ED6,ED6/A,EMT,EMT/A,ENT,ENT/A,ENT2,EN6,EN6/A,ES3,ES3/A,ES4,ES4/A,VC2,VC2/A,VMQ,VMT,VMT/A,VS2,VS3,VS4,VS5,VS6,VS7,VTE2,VWC,VWE



E-14-2

CARBURETOR(3)

M 8

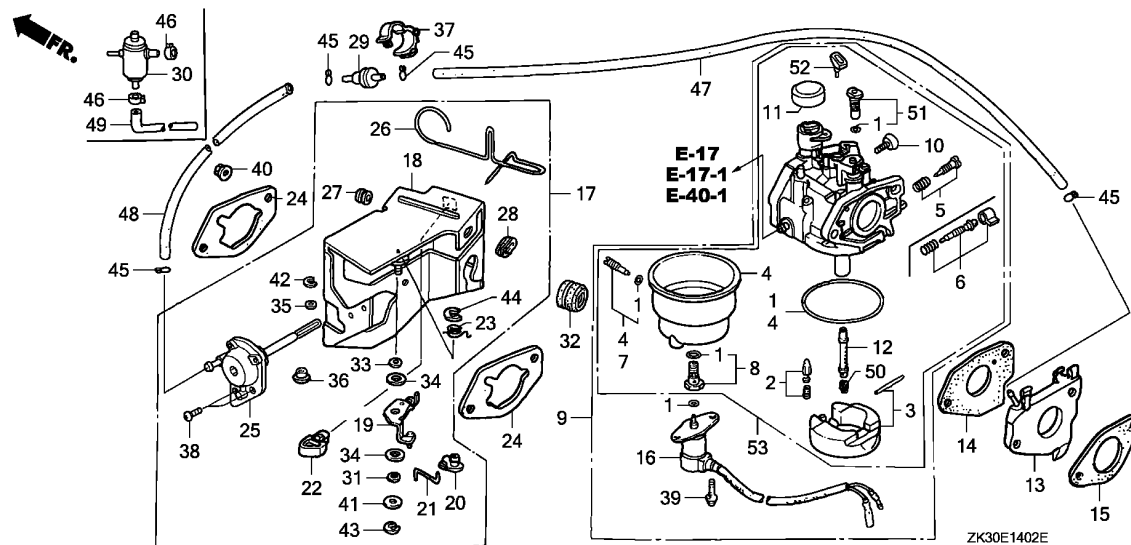

Ref. No.	Part No.	Description	Reqd. QTY			Serial No.	Parts catalogue code
			GX	(1)	(2)		
15	16223-ZE3-800	PACKING, INSULATOR .....	1	-	-	-	EDE2,EDE2/A,EDN,EDN2,EDN2/A,EDS,EDS1,EDS1/A,EDS2,EDS2/A,EDS3,EDS4,EDS6,EDS6/A,EDT,EDT/A,EDT1,EDT1/A,EDT2,EDT3,EDT6,EDT6/A,ED6,ED6/A,EMT,EMT/A,ENT,ENT/A,ENT2,EN6,EN6/A,ES3,ES3/A,ES4,ES4/A,VC2,VC2/A,VMQ,VMT,VMT/A,VS2,VS3,VS4,VS5,VS6,VS7,VTE2,VWC,VWE
16	16230-ZE3-701	VALVE ASSY., SOLENOID .....	1	-	-	-	EDE2,EDE2/A,EDN,EDN2,EDN2/A,EDS,EDS1,EDS2,EDS2/A,EDS3,EDS6,EDS6/A,EDT,EDT/A,EDT1,EDT2,EDT6,EDT6/A,ED6,ED6/A,EMT,ENT,ENT/A,ENT2,EN6,EN6/A,ES3,ES4,VMT,VTE2,VWE
		(CARBURETOR NO.)	1	-	-	4075028	EDS1/A,EDS4,EDT1/A,EMT/A,ES3/A,ES4/A,VMQ,VMT/A,VS3,VS4,VS5,VS6
	16230-ZE3-702	.....	1	-	-	BE82B B	VC2
		.....	1	-	-	-	EDT3,VS2,VS7
17	16260-ZE2-722	STAY ASSY., MANUAL CHOKE ....	1	-	-	4075029	EDS1/A,EDS4,EDT1/A,EMT/A,ES3/A,ES4/A,VMQ,VMT/A,VS3,VS4,VS5,VS6
		.....	1	-	-	-	EDE2,EDE2/A,EDN,EDN2,EDN2/A,EDS,EDS1,EDS2,EDS2/A,EDS3,EDS6,EDS6/A,EDT,EDT/A,EDT1,EDT2,EDT6,EDT6/A,ED6,ED6/A,EMT,ENT,ENT/A,ENT2,EN6,EN6/A,ES3,ES4,VC2,VC2/A,VMT,VTE2
	16260-ZE3-D21	.....	1	-	-	4074558	EDS1/A,EDS4,EDT1/A,EMT/A,ES3/A,ES4/A,VMQ,VMT/A,VS3,VS4,VS5,VS6
	16260-ZE2-723	.....	1	-	-	-	VWC,VWE
		.....	1	-	-	-	EDT3,VS2,VS7
		.....	1	-	-	4074559	EDS1/A,EDS4,EDT1/A,EMT/A,ES3/A,ES4/A,VMQ,VMT/A,VS3,VS4,VS5,VS6
18	16261-ZE2-702	STAY COMP., SOLENOID .....	1	-	-	-	EDE2,EDE2/A,EDN,EDN2,EDN2/A,EDS,EDS1,EDS1/A,EDS2,EDS2/A,EDS3,EDS4,EDS6,EDS6/A,EDT,EDT/A,EDT1,EDT1/A,EDT2,EDT3,EDT6,EDT6/A,ED6,ED6/A,EMT,EMT/A,ENT,ENT/A,ENT2,EN6,EN6/A,ES3,ES3/A,ES4,ES4/A,VC2,VC2/A,VMQ,VMT,VMT/A,VS2,VS3,VS4,VS5,VS6,VS7,VTE2,VWC,VWE
19	16262-ZE2-711	LEVER, CHOKE .....	1	-	-	-	EDE2,EDE2/A,EDN,EDN2,EDN2/A,EDS,EDS1,EDS1/A,EDS2,EDS2/A,EDS3,EDS4,EDS6,EDS6/A,EDT,EDT/A,EDT1,EDT1/A,EDT2,EDT3,EDT6,EDT6/A,ED6,ED6/A,EMT,EMT/A,ENT,ENT/A,ENT2,EN6,EN6/A,ES3,ES3/A,ES4,ES4/A,VC2,VC2/A,VMQ,VMT,VMT/A,VS2,VS3,VS4,VS5,VS6,VS7,VTE2,VWC,VWE

Ref. No.	Part No.	Description	Reqd. QTY			Serial No.	Parts catalogue code
			(1)	(2)	(3)		
20	16263-ZA0-000	JOINT, ROD .....	1	-	-	EDE2,EDE2/A,EDN,EDN2,EDN2/A,EDS,EDS1,EDS1/A,EDS2,EDS2/A,EDS3,EDS4,EDS6,EDS6/A,EDT,EDT/A,EDT1,EDT1/A,EDT2,EDT3,EDT6,EDT6/A,ED6,ED6/A,EMT,EMT/A,ENT,ENT/A,ENT2,EN6,EN6/A,ES3,ES3/A,ES4,ES4/A,VC2,VC2/A,VMQ,VMT,VMT/A,VS2,VS3,VS4,VS5,VS6,VS7,VTE2,VWC,VWE	
21	16264-ZE2-701	ROD, CHOKE .....	1	-	-	EDE2,EDE2/A,EDN,EDN2,EDN2/A,EDS,EDS1,EDS1/A,EDS2,EDS2/A,EDS3,EDS4,EDS6,EDS6/A,EDT,EDT/A,EDT1,EDT1/A,EDT2,EDT3,EDT6,EDT6/A,ED6,ED6/A,EMT,EMT/A,ENT,ENT/A,ENT2,EN6,EN6/A,ES3,ES3/A,ES4,ES4/A,VC2,VC2/A,VMQ,VMT,VMT/A,VS2,VS3,VS4,VS5,VS6,VS7,VTE2,VWC,VWE	
22	16265-ZE2-721	STOPPER, CHOKE ROD .....	1	-	-	EDE2,EDE2/A,EDN,EDN2,EDN2/A,EDS,EDS1,EDS1/A,EDS2,EDS2/A,EDS3,EDS4,EDS6,EDS6/A,EDT,EDT/A,EDT1,EDT1/A,EDT2,EDT3,EDT6,EDT6/A,ED6,ED6/A,EMT,EMT/A,ENT,ENT/A,ENT2,EN6,EN6/A,ES3,ES3/A,ES4,ES4/A,VC2,VC2/A,VMQ,VMT,VMT/A,VS2,VS3,VS4,VS5,VS6,VS7,VTE2,VWC,VWE	
23	16268-ZE2-721	SPRING, MANUAL CHOKE .....	1	-	-	EDE2,EDE2/A,EDN,EDN2,EDN2/A,EDS,EDS1,EDS1/A,EDS2,EDS2/A,EDS3,EDS4,EDS6,EDS6/A,EDT,EDT/A,EDT1,EDT1/A,EDT2,EDT3,EDT6,EDT6/A,ED6,ED6/A,EMT,EMT/A,ENT,ENT/A,ENT2,EN6,EN6/A,ES3,ES3/A,ES4,ES4/A,VC2,VC2/A,VMQ,VMT,VMT/A,VS2,VS3,VS4,VS5,VS6,VS7,VTE2,VWC,VWE	
24	16269-ZA0-800	PACKING, AIR CLEANER .....	2	-	-	EDE2,EDE2/A,EDN,EDN2,EDN2/A,EDS,EDS1,EDS1/A,EDS2,EDS2/A,EDS3,EDS4,EDS6,EDS6/A,EDT,EDT/A,EDT1,EDT1/A,EDT2,EDT3,EDT6,EDT6/A,ED6,ED6/A,EMT,EMT/A,ENT,ENT/A,ENT2,EN6,EN6/A,ES3,ES3/A,ES4,ES4/A,VC2,VC2/A,VMQ,VMT,VMT/A,VS2,VS3,VS4,VS5,VS6,VS7,VTE2,VWC,VWE	
25	16400-ZE2-703	DIAPHRAGM ASSY. ....	1	-	-	EDE2,EDE2/A,EDN,EDN2,EDN2/A,EDS,EDS1,EDS2,EDS2/A,EDS3,EDS6,EDS6/A,EDT,EDT/A,EDT1,EDT2,EDT6,EDT6/A,ED6,ED6/A,EMT,ENT,ENT/A,ENT2,EN6,EN6/A,ES3,ES4,VC2,VC2/A,VMT,VTE2,VWC,VWE	
	16400-ZE2-704	.....	1	-	-	EDS1/A,EDS4,EDT1/A,EMT/A,ES3/A,ES4/A,VMQ,VMT/A,VS3,VS4,VS5,VS6	
		.....	1	-	-	EDT3,VS2,VS7	
		.....	1	-	4074559	EDS1/A,EDS4,EDT1/A,EMT/A,ES3/A,ES4/A,VMQ,VMT/A,VS3,VS4,VS5,VS6	
26	16611-ZE2-711	ROD, CHOKE CONTROL .....	1	-	-	EDE2,EDE2/A,EDN,EDN2,EDN2/A,EDS,EDS1,EDS1/A,EDS2,EDS2/A,EDS3,EDS4,EDS6,EDS6/A,EDT,EDT/A,EDT1,EDT1/A,EDT2,EDT3,EDT6,EDT6/A,ED6,ED6/A,EMT,EMT/A,ENT,ENT/A,ENT2,EN6,EN6/A,ES3,ES3/A,ES4,ES4/A,VC2,VC2/A,VMQ,VMT,VMT/A,VS2,VS3,VS4,VS5,VS6,VS7,VTE2	
	16611-ZE3-D21	.....	1	-	-	VWC,VWE	
27	16613-893-000	GROMMET, CHOKE ROD .....	1	-	-	EDE2,EDE2/A,EDN,EDN2,EDN2/A,EDS,EDS1,EDS1/A,EDS2,EDS2/A,EDS3,EDS4,EDS6,EDS6/A,EDT,EDT/A,EDT1,EDT1/A,EDT2,EDT3,EDT6,EDT6/A,ED6,ED6/A,EMT,EMT/A,ENT,ENT/A,ENT2,EN6,EN6/A,ES3,ES3/A,ES4,ES4/A,VC2,VC2/A,VMQ,VMT,VMT/A,VS2,VS3,VS4,VS5,VS6,VS7,VTE2,VWC,VWE	
28	16615-893-000	GUIDE, CHOKE ROD .....	1	-	-	EDE2,EDE2/A,EDN,EDN2,EDN2/A,EDS,EDS1,EDS1/A,EDS2,EDS2/A,EDS3,EDS4,EDS6,EDS6/A,EDT,EDT/A,EDT1,EDT1/A,EDT2,EDT3,EDT6,EDT6/A,ED6,ED6/A,EMT,EMT/A,ENT,ENT/A,ENT2,EN6,EN6/A,ES3,ES3/A,ES4,ES4/A,VC2,VC2/A,VMQ,VMT,VMT/A,VS2,VS3,VS4,VS5,VS6,VS7,VTE2,VWC,VWE	
29	36135-ZV1-003	VALVE, DASHPOT CHECK .....	1	-	-	2362349 EDN,EDS,EDS1,EDS3,EDT1,ED6,ES3,ES4	
	36135-ZF6-D41	.....	1	-	-	EDE2,EDE2/A,EDN2,EDN2/A,EDS1/A,EDS2,EDS2/A,EDS4,EDS6,EDS6/A,EDT,EDT/A,EDT1/A,EDT2,EDT3,EDT6,EDT6/A,ED6/A,EMT,EMT/A,ENT,ENT/A,ENT2,EN6,EN6/A,ES3/A,ES4/A,VC2,VC2/A,VMQ,VMT,VMT/A,VS2,VS3,VS4,VS5,VS6,VS7,VTE2,VWC,VWE	
		.....	1	-	2362350	EDN,EDS,EDS1,EDS3,EDT1,ED6,ES3,ES4	
30	36170-ZB4-003	VALVE ASSY., SOLENOID .....	1	-	-	EDS3	
31	53149-964-003	BUSH, ARM PIVOT .....	1	-	-	EDE2,EDE2/A,EDN,EDN2,EDN2/A,EDS,EDS1,EDS1/A,EDS2,EDS2/A,EDS3,EDS4,EDS6,EDS6/A,EDT,EDT/A,EDT1,EDT1/A,EDT2,EDT3,EDT6,EDT6/A,ED6,ED6/A,EMT,EMT/A,ENT,ENT/A,ENT2,EN6,EN6/A,ES3,ES3/A,ES4,ES4/A,VC2,VC2/A,VMQ,VMT,VMT/A,VS2,VS3,VS4,VS5,VS6,VS7,VTE2,VWC,VWE	
32	88911-MJ3-000	GROMMET, FENDER .....	1	-	-	EDE2,EDE2/A,EDN,EDN2,EDN2/A,EDS,EDS1,EDS1/A,EDS2,EDS2/A,EDS3,EDS4,EDS6,EDS6/A,EDT,EDT/A,EDT1,EDT1/A,EDT2,EDT3,EDT6,EDT6/A,ED6,ED6/A,EMT,EMT/A,ENT,ENT/A,ENT2,EN6,EN6/A,ES3,ES3/A,ES4,ES4/A,VC2,VC2/A,VMQ,VMT,VMT/A,VS2,VS3,VS4,VS5,VS6,VS7,VTE2,VWC,VWE	



E-14-2

CARBURETOR(3)

M10

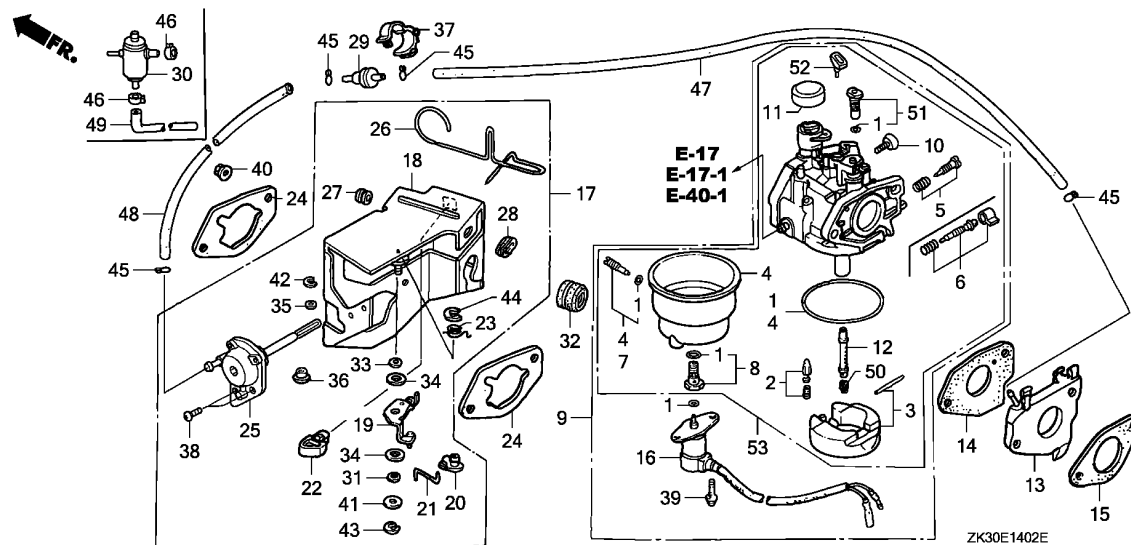

ZK30E1402E

Ref. No.	Part No.	Description	Reqd. QTY			Serial No.	Parts catalogue code
			GX	(1)	(2)		
33	90431-ZE2-700	WASHER, CHOKE LEVER .....	1	-	-	-	EDE2,EDE2/A,EDN,EDN2,EDN2/A,EDS,EDS1,EDS1/A,EDS2,EDS2/A,EDS3,EDS4,EDS6,EDS6/A,EDT,EDT/A,EDT1,EDT1/A,EDT2,EDT3,EDT6,EDT6/A,ED6,ED6/A,EMT,EMT/A,ENT,ENT/A,ENT2,EN6,EN6/A,ES3,ES3/A,ES4,ES4/A,VC2,VC2/A,VMQ,VMT,VMT/A,VS2,VS3,VS4,VS5,VS6,VS7,VTE2,VWC,VWE
34	90432-ZE2-700	SEAL, CHOKE LEVER .....	2	-	-	-	EDE2,EDE2/A,EDN,EDN2,EDN2/A,EDS,EDS1,EDS1/A,EDS2,EDS2/A,EDS3,EDS4,EDS6,EDS6/A,EDT,EDT/A,EDT1,EDT1/A,EDT2,EDT3,EDT6,EDT6/A,ED6,ED6/A,EMT,EMT/A,ENT,ENT/A,ENT2,EN6,EN6/A,ES3,ES3/A,ES4,ES4/A,VC2,VC2/A,VMQ,VMT,VMT/A,VS2,VS3,VS4,VS5,VS6,VS7,VTE2,VWC,VWE
35	90433-ZE2-700	WASHER, THRUST, 2.7X8 .....	1	-	-	-	EDE2,EDE2/A,EDN,EDN2,EDN2/A,EDS,EDS1,EDS1/A,EDS2,EDS2/A,EDS3,EDS4,EDS6,EDS6/A,EDT,EDT/A,EDT1,EDT1/A,EDT2,EDT3,EDT6,EDT6/A,ED6,ED6/A,EMT,EMT/A,ENT,ENT/A,ENT2,EN6,EN6/A,ES3,ES3/A,ES4,ES4/A,VC2,VC2/A,VMQ,VMT,VMT/A,VS2,VS3,VS4,VS5,VS6,VS7,VTE2,VWC,VWE
36	90434-ZE2-700	COLLAR, LEVER .....	1	-	-	-	EDE2,EDE2/A,EDN,EDN2,EDN2/A,EDS,EDS1,EDS1/A,EDS2,EDS2/A,EDS3,EDS4,EDS6,EDS6/A,EDT,EDT/A,EDT1,EDT1/A,EDT2,EDT3,EDT6,EDT6/A,ED6,ED6/A,EMT,EMT/A,ENT,ENT/A,ENT2,EN6,EN6/A,ES3,ES3/A,ES4,ES4/A,VC2,VC2/A,VMQ,VMT,VMT/A,VS2,VS3,VS4,VS5,VS6,VS7,VTE2,VWC,VWE
37	90650-SD9-003	CLIP, WIRE HARNESS .....	1	-	-	-	EDE2,EDE2/A,EDN,EDN2,EDN2/A,EDS,EDS1,EDS1/A,EDS2,EDS2/A,EDS4,EDS6,EDS6/A,EDT,EDT/A,EDT1,EDT1/A,EDT2,EDT3,EDT6,EDT6/A,ED6,ED6/A,EMT,EMT/A,ENT,ENT/A,ENT2,EN6,EN6/A,ES3,ES3/A,ES4,ES4/A,VC2,VC2/A,VMQ,VMT,VMT/A,VS2,VS3,VS4,VS5,VS6,VS7,VTE2,VWC,VWE
38	93500-05012-0A	SCREW, PAN, 5X12 .....	2	-	-	-	EDE2,EDE2/A,EDN,EDN2,EDN2/A,EDS,EDS1,EDS1/A,EDS2,EDS2/A,EDS3,EDS4,EDS6,EDS6/A,EDT,EDT/A,EDT1,EDT1/A,EDT2,EDT3,EDT6,EDT6/A,ED6,ED6/A,EMT,EMT/A,ENT,ENT/A,ENT2,EN6,EN6/A,ES3,ES3/A,ES4,ES4/A,VC2,VC2/A,VMQ,VMT,VMT/A,VS2,VS3,VS4,VS5,VS6,VS7,VTE2,VWC,VWE
39	93892-05012-08	SCREW-WASHER, 5X12 .....	2	-	-	-	EDE2,EDE2/A,EDN2,EDN2/A,EDS2,EDS2/A,EDS6,EDS6/A,EDT,EDT/A,EDT2,EDT6,EDT6/A,ED6,ED6/A,EMT,ENT,ENT/A,ENT2,EN6,EN6/A,VTE2,VWE
	(CARBURETOR NO.)		2	-	-	BE82B B VC2	

**E-14-2**

**CARBURETOR(3)**



Ref. No.	Part No.	Description	Reqd. QTY			Serial No.	Parts catalogue code
			(1)	(2)	(3)		
39)	93892-05012-18	SCREW-WASHER, 5X12 .....	2	-	-	-----	EDN,EDS,EDS1,EDS1/A,EDS3,EDS4,EDT1,EDT1/A,EDT3,EMT/A,ES3,ES3/A,ES4,ES4/A,VMQ,VMT,VMT/A,VS2,VS3,VS4,VS5,VS6,VS7
40	94050-06000	NUT, FLANGE, 6MM .....	2	-	-	-----	EDE2,EDE2/A,EDN,EDN2,EDN2/A,EDS,EDS1,EDS1/A,EDS2,EDS2/A,EDS3,EDS4,EDS6,EDS6/A,EDT,EDT/A,EDT1,EDT1/A,EDT2,EDT3,EDT6,EDT6/A,ED6,ED6/A,EMT,EMT/A,ENT,ENT/A,ENT2,EN6,EN6/A,ES3,ES3/A,ES4,ES4/A,VC2,VC2/A,VMQ,VMT,VMT/A,VS2,VS3,VS4,VS5,VS6,VS7,VTE2,VWC,VWE
41	94103-05000	WASHER, PLAIN, 5MM .....	1	-	-	-----	EDE2,EDE2/A,EDN,EDN2,EDN2/A,EDS,EDS1,EDS1/A,EDS2,EDS2/A,EDS3,EDS4,EDS6,EDS6/A,EDT,EDT/A,EDT1,EDT1/A,EDT2,EDT3,EDT6,EDT6/A,ED6,ED6/A,EMT,EMT/A,ENT,ENT/A,ENT2,EN6,EN6/A,ES3,ES3/A,ES4,ES4/A,VC2,VC2/A,VMQ,VMT,VMT/A,VS2,VS3,VS4,VS5,VS6,VS7,VTE2,VWC,VWE
42	94540-02010	E-RING, 2MM .....	1	-	-	-----	EDE2,EDE2/A,EDN,EDN2,EDN2/A,EDS,EDS1,EDS1/A,EDS2,EDS2/A,EDS3,EDS4,EDS6,EDS6/A,EDT,EDT/A,EDT1,EDT1/A,EDT2,EDT3,EDT6,EDT6/A,ED6,ED6/A,EMT,EMT/A,ENT,ENT/A,ENT2,EN6,EN6/A,ES3,ES3/A,ES4,ES4/A,VC2,VC2/A,VMQ,VMT,VMT/A,VS2,VS3,VS4,VS5,VS6,VS7,VTE2,VWC,VWE
43	94540-04010	E-RING, 4MM .....	1	-	-	-----	EDE2,EDE2/A,EDN,EDN2,EDN2/A,EDS,EDS1,EDS1/A,EDS2,EDS2/A,EDS3,EDS4,EDS6,EDS6/A,EDT,EDT/A,EDT1,EDT1/A,EDT2,EDT3,EDT6,EDT6/A,ED6,ED6/A,EMT,EMT/A,ENT,ENT/A,ENT2,EN6,EN6/A,ES3,ES3/A,ES4,ES4/A,VC2,VC2/A,VMQ,VMT,VMT/A,VS2,VS3,VS4,VS5,VS6,VS7,VTE2,VWC,VWE
44	94540-07010	E-RING, 7MM .....	1	-	-	-----	EDE2,EDE2/A,EDN,EDN2,EDN2/A,EDS,EDS1,EDS1/A,EDS2,EDS2/A,EDS3,EDS4,EDS6,EDS6/A,EDT,EDT/A,EDT1,EDT1/A,EDT2,EDT3,EDT6,EDT6/A,ED6,ED6/A,EMT,EMT/A,ENT,ENT/A,ENT2,EN6,EN6/A,ES3,ES3/A,ES4,ES4/A,VC2,VC2/A,VMQ,VMT,VMT/A,VS2,VS3,VS4,VS5,VS6,VS7,VTE2,VWC,VWE
45	95002-02070	CLIP, TUBE (B7) .....	4	-	-	-----	EDE2,EDE2/A,EDN,EDN2,EDN2/A,EDS,EDS1,EDS1/A,EDS2,EDS2/A,EDS3,EDS4,EDS6,EDS6/A,EDT,EDT/A,EDT1,EDT1/A,EDT2,EDT3,EDT6,EDT6/A,ED6,ED6/A,EMT,EMT/A,ENT,ENT/A,ENT2,EN6,EN6/A,ES3,ES3/A,ES4,ES4/A,VC2,VC2/A,VMQ,VMT,VMT/A,VS2,VS3,VS4,VS5,VS6,VS7,VTE2,VWC,VWE
46	95002-40800-08	CLAMP, TUBE (D8) .....	2	-	-	-----	EDS3
47	95005-35075-10	TUBE, 3.5X75(95005-35001-10M)	1	-	-	-----	EDE2,EDE2/A,EDN,EDN2,EDN2/A,EDS,EDS1,EDS1/A,EDS2,EDS2/A,EDS4,EDS6,EDS6/A,EDT,EDT/A,EDT1,EDT1/A,EDT2,EDT3,EDT6,EDT6/A,ED6,ED6/A,EMT,EMT/A,ENT,ENT/A,ENT2,EN6,EN6/A,ES3,ES3/A,ES4,ES4/A,VC2,VC2/A,VMQ,VMT,VMT/A,VS2,VS3,VS4,VS5,VS6,VS7,VTE2,VWC,VWE
	95005-35495-11	TUBE, 3.5X495(95005-35001-10M)	1	-	-	-----	EDS3
48	95005-35130-10	TUBE, 3.5X130(95005-35001-10M)	1	-	-	-----	EDE2,EDE2/A,EDN,EDN2,EDN2/A,EDS,EDS1,EDS1/A,EDS2,EDS2/A,EDS4,EDS6,EDS6/A,EDT,EDT/A,EDT1,EDT1/A,EDT2,EDT3,EDT6,EDT6/A,ED6,ED6/A,EMT,EMT/A,ENT,ENT/A,ENT2,EN6,EN6/A,ES3,ES3/A,ES4,ES4/A,VC2,VC2/A,VMQ,VMT,VMT/A,VS2,VS3,VS4,VS5,VS6,VS7,VTE2,VWC,VWE
	95005-35030-10	TUBE, 3.5X30(95005-35001-10M)	1	-	-	-----	EDS3
49	95005-35695-10	TUBE, 3.5X695(95005-35001-10M)	1	-	-	-----	EDS3
50	99101-ZF5-0920	JET, MAIN, #92 .....	(1)	-	-	-----	BE37B A EDN,EDS,EDS1,EDS3,EDT1,ED6,ES3,ES4
	(CARBURETOR NO.)						
	99101-ZF5-0950	JET, MAIN, #95 .....	(1)	-	-	-----	BE37B A EDN,EDS,EDS1,EDS3,EDT1,ED6,ES3,ES4
	(CARBURETOR NO.)						
	99101-ZF5-0980	JET, MAIN, #98 .....	1	-	-	-----	BE37B A EDN,EDS,EDS1,EDS3,EDT1,ED6,ES3,ES4
	(CARBURETOR NO.)						
	99101-ZH7-0950	JET, MAIN, #95 .....	(1)	-	-	-----	VTE2
	99101-ZH7-0980	JET, MAIN, #98 .....	(1)	-	-	-----	VTE2
	99101-ZH7-1000	JET, MAIN, #100 .....	1	-	-	-----	VTE2
	99101-ZH8-0950	JET, MAIN, #95 .....	(1)	-	-	-----	EDE2,EDE2/A,EDN2,EDN2/A,EDS1/A,EDS2,EDS2/A,EDS4,EDS6,EDS6/A,EDT,EDT/A,EDT1/A,EDT2,EDT3,EDT6,EDT6/A,ED6/A,EMT,EMT/A,ENT,ENT/A,ENT2,EN6,EN6/A,ES3/A,ES4/A,VC2,VC2/A,VMQ,VMT,VMT/A,VS2,VS3,VS4,VS5,VS6,VS7,VWC,VWE
	(CARBURETOR NO.)		(1)	-	-	-----	EDN,EDS,EDS1,EDS3,EDT1,ED6,ES3,ES4



E-14-2

CARBURETOR(3)

M12

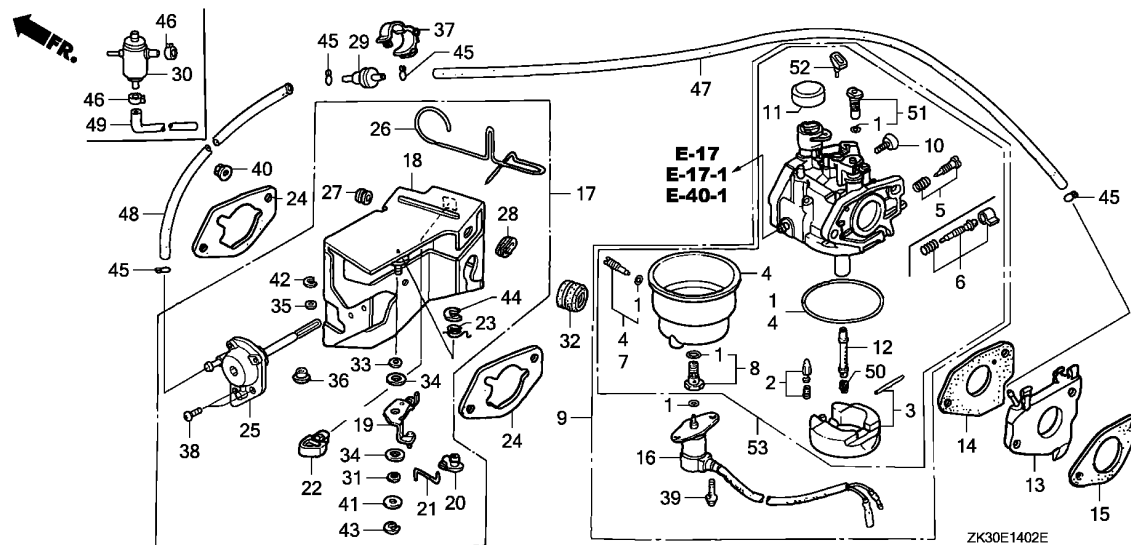

Ref. No.	Part No.	Description	Reqd. QTY			Serial No.	Parts catalogue code	
			GX	340K1				
			(1)	(2)	(3)			
50)	99101-ZH8-0980	JET, MAIN, #98 .....	(1)	-	-	-----	EDE2,EDE2/A,EDN2,EDN2/A,EDS1/A,EDS2,EDS2/A,EDS4,EDS6,EDS6/A,EDT EDT/A,EDT1/A,EDT2,EDT3,EDT6,EDT6/A,ED6/A,EMT,EMT/A,ENT,ENT/A,ENT2 EN6,EN6/A,ES3/A,ES4/A,VC2,VC2/A,VMQ,VMT,VMT/A,VS2,VS3,VS4,VS5,VS6 VS7,VWC,VWE	
		(CARBURETOR NO.)	(1)	-	-	BE37B B	-----	EDN,EDS,EDS1,EDS3,EDT1,ED6,ES3,ES4
	99101-ZH8-1000	JET, MAIN, #100 .....	1	-	-	-----	EDE2,EDE2/A,EDN2,EDN2/A,EDS1/A,EDS2,EDS2/A,EDS4,EDS6,EDS6/A,EDT EDT/A,EDT1/A,EDT2,EDT3,EDT6,EDT6/A,ED6/A,EMT,EMT/A,ENT,ENT/A,ENT2 EN6,EN6/A,ES3/A,ES4/A,VC2,VC2/A,VMQ,VMT,VMT/A,VS2,VS3,VS4,VS5,VS6 VS7,VWC,VWE	
		(CARBURETOR NO.)	1	-	-	BE37B B	-----	EDN,EDS,EDS1,EDS3,EDT1,ED6,ES3,ES4
51	99204-ZE0-0450	JET SET, PILOT, #45 .....	1	-	-	-----	BE37B A EDN,EDS,EDS1,EDS3,EDT1,ED6,ES3,ES4	
		(CARBURETOR NO.)	1	-	-	-----	-----	EDN,EDS,EDS1,EDS3,EDT1,ED6,ES3,ES4
	99204-ZE0-0350	JET SET, PILOT, #35 .....	1	-	-	-----	EDE2,EDE2/A,EDN2,EDN2/A,EDS1/A,EDS2,EDS2/A,EDS4,EDS6,EDS6/A,EDT EDT/A,EDT1/A,EDT2,EDT3,EDT6,EDT6/A,ED6/A,EMT,EMT/A,ENT,ENT/A,ENT2 EN6,EN6/A,ES3/A,ES4/A,VC2,VC2/A,VMQ,VMT,VMT/A,VS2,VS3,VS4,VS5,VS6 VS7,VTE2,VWC,VWE	
		(CARBURETOR NO.)	1	-	-	BE37B B	-----	EDN,EDS,EDS1,EDS3,EDT1,ED6,ES3,ES4
52	16172-ZE3-W10	COLLAR, SETTING .....	1	-	-	-----	EDE2,EDE2/A,EDN2,EDN2/A,EDS1/A,EDS2,EDS2/A,EDS4,EDS6,EDS6/A,EDT EDT/A,EDT1/A,EDT2,EDT3,EDT6,EDT6/A,ED6/A,EMT,EMT/A,ENT,ENT/A,ENT2 EN6,EN6/A,ES3/A,ES4/A,VC2,VC2/A,VMQ,VMT,VMT/A,VS2,VS3,VS4,VS5,VS6 VS7,VTE2,VWC,VWE	
		(CARBURETOR NO.)	1	-	-	BE37B B	-----	EDN,EDS,EDS1,EDS3,EDT1,ED6,ES3,ES4
53	16100-ZK3-S61	CARBURETOR ASSY. (BE82E A) ..	1	-	-	-----	-----	EDN,EDS,EDS1,EDS3,EDT1,ED6,ES3,ES4 VC2/A,VWC

# E-14-3

# CARBURETOR(4)

**M13**

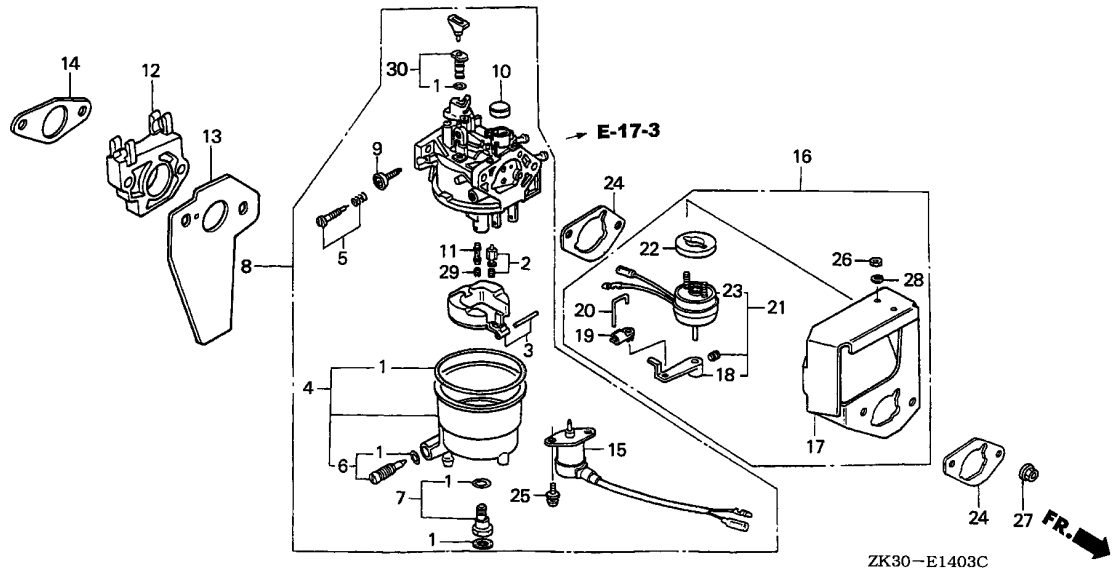

Ref. No.	L.O.N.	(Relative ref. Number) Description	F.R.T.
1	3111G1	GASKET SET, CARBURETOR(A) .... (3)	0.4
2	3111G6	VALVE SET, FLOAT AND/OR FLOAT SET(A) .....	0.4
4	3111M2	CHAMBER SET, FLOAT AND/OR GASKET, FLOAT CHAMBER(A) ....	0.3
5	3111D7	SCREW SET, PILOT .....	0.2
8	3111G7	CARBURETOR(A) .....	0.3
12	3111G2	INSULATOR, CARBURETOR AND/OR PACKING, INSULATOR(A) .....	0.3
13	3111G5	PACKING, CARBURETOR(A) .....	0.3
15	6211C0	VALVE, CARBURETOR SOLENOID ...	0.2
16	8101BH	STAY ASSEMBLY, ROTARY CHOKE SOLENOID .....	0.2
17	8101R2	STAY, ROTARY CHOKE SOLENOID ..	0.3
20	8101J8	ROD, CARBURETOR CHOKE .....	0.2
23	8101R0	SOLENOID, ROTARY CHOKE .....	0.3
24	3121H2	PACKING, AIR CLEANER(A) .....	0.3
29	3111G4	JET, MAIN(A) .....	0.4

Ref. No.	Part No.	Description	Reqd. QTY			Serial No.	Parts catalogue code
			GX	340K1			
			(1)	(2)	(3)		
1	16010-ZE3-701	GASKET SET .....	1	-	-	EDS5	
2	16011-ZA0-931	VALVE SET, FLOAT .....	1	-	-	EDS5	
3	16013-ZA0-931	FLOAT SET .....	1	-	-	EDS5	
4	16015-ZA0-931	CHAMBER SET, FLOAT .....	1	-	-	EDS5	
5	16016-ZE0-005	SCREW SET, PILOT .....	1	-	-	EDS5	
6	16024-124-760	SCREW SET, DRAIN .....	1	-	-	EDS5	
7	16028-ZE3-701	SCREW SET .....	1	-	-	EDS5	
8	16100-ZB8-035	CARBURETOR ASSY. (BE38A D/E)	1	-	-	EDS5	
9	16124-ZE0-005	SCREW, THROTTLE STOP .....	1	-	-	EDS5	
10	16148-141-881	CAP, CHOKE DUST .....	1	-	-	EDS5	
11	16166-ZE3-701	NOZZLE, MAIN .....	1	-	-	EDS5	
12	16211-ZB8-000	INSULATOR, CARBURETOR .....	1	-	-	EDS5	
13	16221-ZB7-800	PACKING, CARBURETOR .....	1	-	-	2362400	EDS5
14	16223-ZE3-800	PACKING, INSULATOR .....	1	-	-	EDS5	
15	16230-ZE3-701	VALVE ASSY., SOLENOID .....	1	-	-	EDS5	
16	16260-ZB7-000	STAY ASSY., SOLENOID .....	1	-	-	EDS5	
17	16261-ZB7-000	STAY COMP., CHOKE SOLENOID ..	1	-	-	EDS5	
18	16262-ZB7-000	LEVER, CHOKE SOLENOID .....	1	-	-	EDS5	
19	16263-ZA0-000	JOINT, ROD .....	1	-	-	EDS5	
20	16264-ZB7-000	ROD, CHOKE SOLENOID .....	1	-	-	EDS5	
21	16265-ZB7-000	SOLENOID ASSY., CHOKE .....	1	-	-	EDS5	
22	16266-ZB7-000	SPACER, CHOKE SOLENOID .....	1	-	-	EDS5	
23	16267-ZB7-003	SOLENOID, ROTARY CHOKE .....	1	-	-	EDS5	
24	16269-ZA0-800	PACKING, AIR CLEANER .....	2	-	-	EDS5	
25	93892-05012-08	SCREW-WASHER, 5X12 .....	2	-	-	EDS5	

**2**

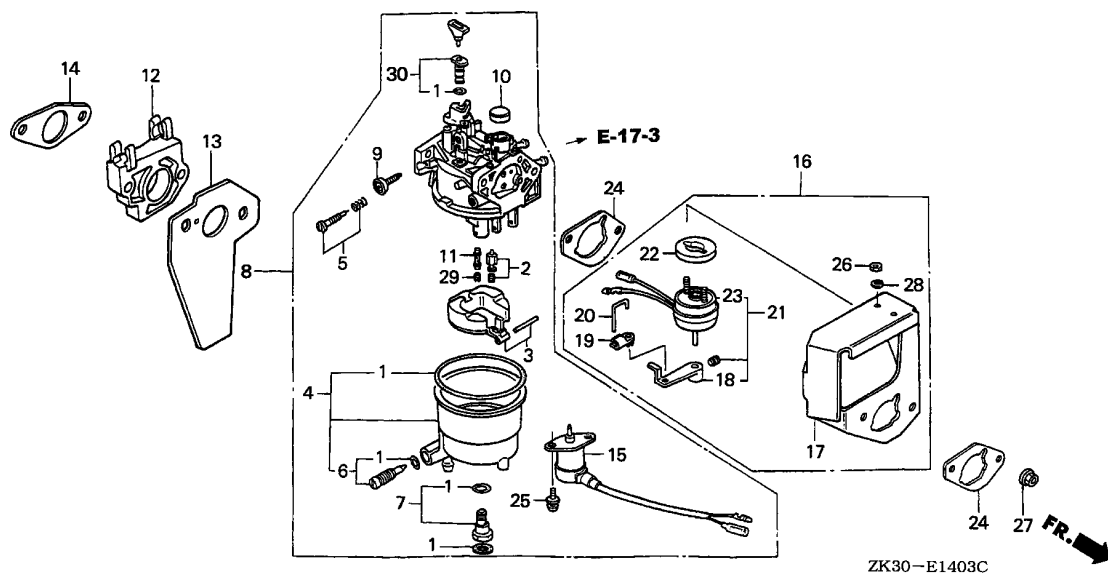

Ref. No.	Part No.	Description	Reqd. QTY			Serial No.	Parts catalogue code
			GX	340K1			
			(1)	(2)	(3)		
26	94001-03000-0S	NUT, HEX., 3MM .....	2	-	-	-----	EDS5
27	94050-06000	NUT, FLANGE, 6MM .....	2	-	-	-----	EDS5
28	94111-03800	WASHER, SPRING, 3MM .....	2	-	-	-----	EDS5
29	99101-ZH8-0920	JET, MAIN, #92 .....	(1)	-	-	-----	EDS5
	99101-ZH8-0950	JET, MAIN, #95 .....	(1)	-	-	-----	EDS5
	99101-ZH8-0980	JET, MAIN, #98 .....	1	-	-	-----	EDS5
30	99204-ZE2-0380	JET SET, PILOT, #38 .....	1	-	-	-----	EDS5



E-14-4

CARBURETOR(5)

M15

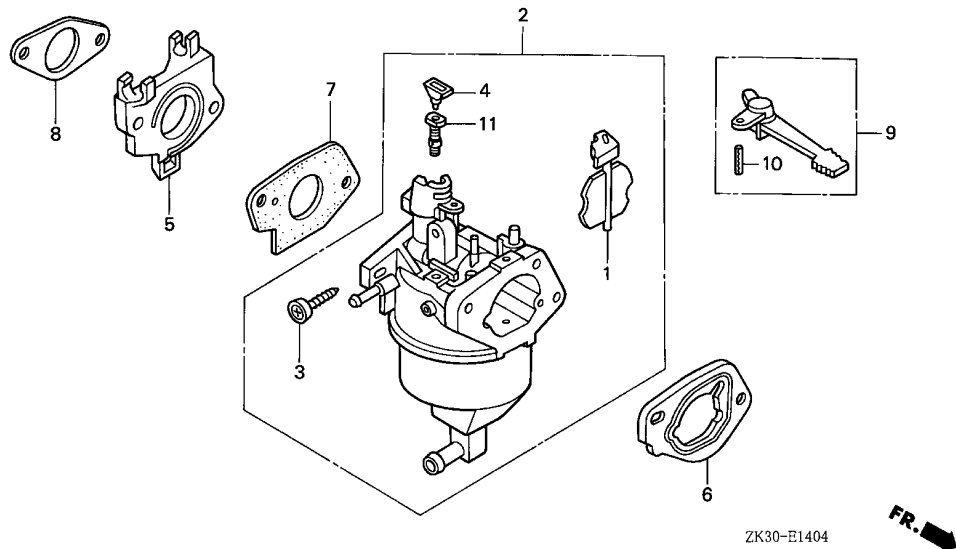

Ref. No.	L.O.N.	(Relative ref. Number) Description	F.R.T.
1	8101C5	CHOKE SET, CARBURETOR .....	0.2
2	3111F3	CARBURETOR .....	0.2
5	3111C0	INSULATOR, CARBURETOR AND/OR PACKING, INSULATOR .....	0.2
6	3111D9	SPACER, CARBURETOR .....	0.2
7	3111C8	PACKING, CARBURETOR .....	0.2
9	8101F9	LEVER, CARBURETOR CHOKE .....	0.2

Ref. No.	Part No.	Description	Reqd. QTY			Serial No.	Parts catalogue code
			GX	340K1	(3)		
			(1)	(2)	(3)		
1	16044-ZE3-W61	CHOKE SET .....	-	-	1		
2	16100-ZE3-W61	CARBURETOR ASSY. (BEL4A A) ..	-	-	1		
3	16124-ZE0-005	SCREW, THROTTLE STOP .....	-	-	1		
4	16172-ZE3-W10	COLLAR, SETTING .....	-	-	1		
5	16211-ZF6-000	INSULATOR, CARBURETOR .....	-	-	1		
6	16220-ZA0-702	SPACER COMP., CARBURETOR .....	-	-	1		
7	16221-ZF6-800	PACKING, CARBURETOR .....	-	-	1		
8	16223-ZE3-W00	PACKING, INSULATOR .....	-	-	1		
9	16610-ZE1-000	LEVER COMP., CHOKE (STD.) .....	-	-	1		
10	94305-20122	PIN, SPRING, 2X12 .....	-	-	1		
11	99104-ZE0-0450	JET, PILOT, #45 .....	-	-	1		

2

# E-14-5

# CARBURETOR(6)

M16

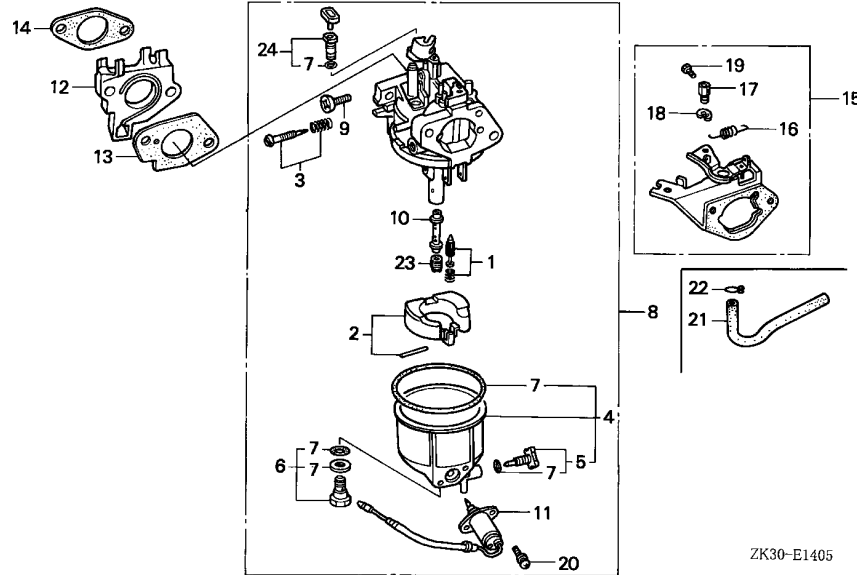

Ref. No.	L.O.N.	(Relative ref. Number) Description	F.R.T.
1		(2)	
3111E1		VALVE SET, FLOAT AND/OR FLOAT SET .....	0.3
3	3111D7	SCREW SET, PILOT .....	0.2
4	3111A3	CHAMBER SET, FLOAT AND/OR GASKET, FLOAT CHAMBER .....	0.2
8	3111F3	CARBURETOR .....	0.2
11	6211C0	VALVE, CARBURETOR SOLENOID (14)	0.2
12	3111C0	INSULATOR, CARBURETOR AND/OR PACKING, INSULATOR .....	0.2
13	3111C8	PACKING, CARBURETOR .....	0.2
15	3111D0	STAY, CHOKE CONTROL(A) .....	0.3
16	3111M8	SPRING, CHOKE CONTROL STAY RETURN .....	0.1
21	3101F6	TUBE, FUEL .....	0.1
23	3111C3	JET, MAIN .....	0.3

Ref. No.	Part No.	Description	Reqd. QTY			Serial No.	Parts catalogue code
			GX	340K1	(3)		
1	16011-ZA0-931	VALVE SET, FLOAT .....	1	-	-	ZK1,ZK1/A	
2	16013-ZA0-931	FLOAT SET .....	1	-	-	ZK1,ZK1/A	
3	16016-ZE0-005	SCREW SET, PILOT .....	1	-	-	ZK1,ZK1/A	
4	16023-ZE3-L60	CHAMBER SET, FLOAT .....	1	-	-	ZK1,ZK1/A	
5	16024-ZE3-L60	SCREW SET, DRAIN .....	1	-	-	ZK1,ZK1/A	
6	16028-ZA0-981	SCREW SET .....	1	-	-	ZK1,ZK1/A	
7	16040-ZA0-702	GASKET SET .....	1	-	-	ZK1,ZK1/A	
8	16100-ZE3-L60	CARBURETOR ASSY. (BE30D A) ..	1	-	-	2527183 ZK1	
	16100-ZE3-L62	CARBURETOR ASSY. (BE30D D) ..	1	-	-	2527184 2767218 ZK1	
	16100-ZE3-L63	CARBURETOR ASSY. (BE30D E) ..	1	-	-	ZK1/A	
9	16124-ZE0-005	SCREW, THROTTLE STOP .....	1	-	-	2767219 ZK1	
10	16166-ZE3-811	NOZZLE, MAIN .....	1	-	-	ZK1,ZK1/A	
11	16200-ZJ1-003	VALVE ASSY., SOLENOID .....	1	-	-	ZK1,ZK1/A	
12	16211-ZE3-000	INSULATOR, CARBURETOR .....	1	-	-	ZK1,ZK1/A	
13	16221-ZE3-800	PACKING, CARBURETOR .....	1	-	-	ZK1,ZK1/A	
14	16223-ZE3-W00	PACKING, INSULATOR .....	1	-	-	ZK1,ZK1/A	
15	16590-ZE3-L60	STAY ASSY., CHOKE CONTROL (REMOTE)	1	-	-	2375015 ZK1	
	16590-ZE3-L62	.....	1	-	-	2375016 2492684 ZK1	
	16590-ZE3-L63	.....	1	-	-	ZK1/A	
		.....	1	-	-	2492685 ZK1	
16	16615-ZE2-810	SPRING, RETURN .....	1	-	-	ZK1,ZK1/A	
17	16617-ZE3-H00	HOLDER, WIRE .....	1	-	-	2375015 ZK1	
	16594-883-010	.....	1	-	-	ZK1/A	
		.....	1	-	-	2375016 ZK1	

2

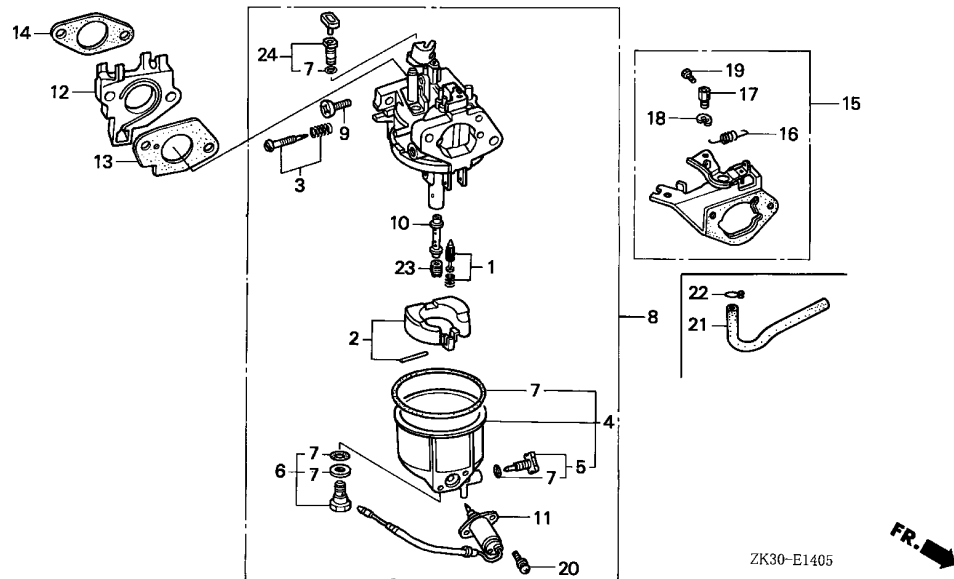

Ref. No.	Part No.	Description	Reqd. QTY			Serial No.	Parts catalogue code
			GX 340K1 (1)	(2)	(3)		
18	90605-230-000	CIRCLIP, 5MM .....	1	-	-	-----	ZK1,ZK1/A
19	92301-04006-0A	BOLT, RECESSED, 4X6 .....	1	-	-	-----	ZK1,ZK1/A
20	93892-05012-18	SCREW-WASHER, 5X12 .....	2	-	-	-----	ZK1,ZK1/A
21	95001-45260-40	TUBE, FUEL, 4.5X260 (95001-45001-60M)	1	-	-	-----	ZK1/A
			1	-	-	2616064	ZK1
22	95002-02080	CLIP, TUBE (B8) .....	1	-	-	-----	ZK1/A
			1	-	-	2616064	ZK1
23	99101-ZH7-0950	JET, MAIN, #95 .....	1	-	-	-----	BE30D A ZK1
	99101-ZH7-0980	JET, MAIN, #98 .....	1	-	-	-----	ZK1/A
		(CARBURETOR NO.)	1	-	-	BE30D D	ZK1
24	99204-ZE0-0350	JET SET, PILOT, #35 .....	1	-	-	-----	BE30D D ZK1
	99204-ZA0-0400	JET SET, PILOT, #40 .....	1	-	-	-----	ZK1/A
		(CARBURETOR NO.)	1	-	-	BE30D E	ZK1



E-14-6

CARBURETOR(7)

N 2

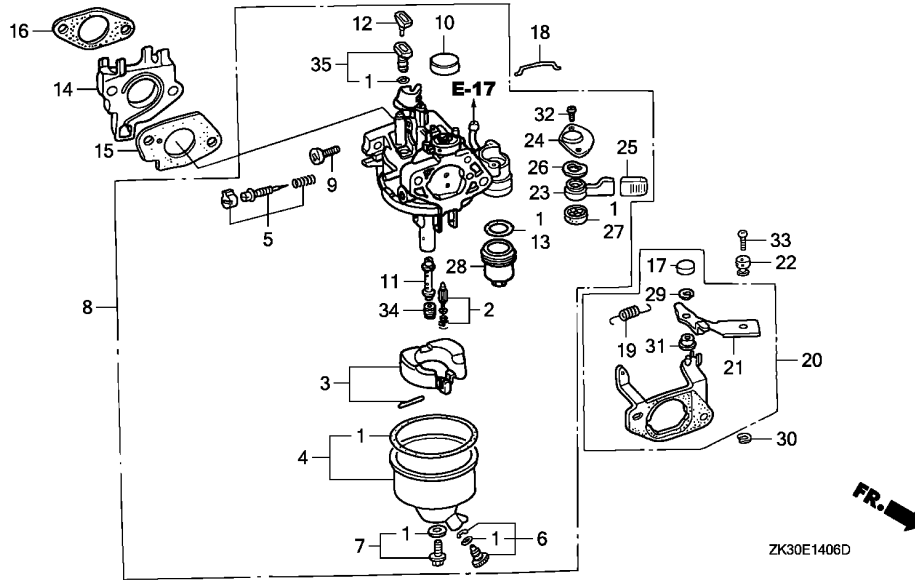

Ref. No.	L.O.N.	(Relative ref. Number) Description	F.R.T.
1	3111B1	GASKET SET, CARBURETOR .....	0.3
2	3111E1	VALVE SET, FLOAT AND/OR FLOAT SET .....	0.3
4	3111A3	CHAMBER SET, FLOAT AND/OR GASKET, FLOAT CHAMBER .....	0.2
5	3111D7	SCREW SET, PILOT .....	0.2
8	3111F3	CARBURETOR .....	0.2
13	3101L6	PACKING, FUEL STRAINER CUP ... (16)	0.2
14	3111C0	INSULATOR, CARBURETOR AND/OR PACKING, INSULATOR .....	0.2
15	3111C8	PACKING, CARBURETOR .....	0.2
18	8101J8	ROD, CARBURETOR CHOKE .....	0.2
19	3131J6	SPRING, CARBURETOR THROTTLE RETURN .....	0.1
20	3111D0	STAY, CHOKE CONTROL(A) .....	0.3
27	3101C5	PACKING, FUEL COCK .....	0.2
34	3111C3	JET, MAIN .....	0.3

ZK30E1406D

FR. →

Ref. No.	Part No.	Description	Reqd. QTY			Serial No.	Parts catalogue code
			GX	340K1			
			(1)	(2)	(3)		
1	16010-ZE2-A20	GASKET SET (INCLUDE 16173-001-004)	1	-	-	-----	LWD1,LWD1/A
2	16011-ZA0-931	VALVE SET, FLOAT .....	1	-	-	-----	LWD1,LWD1/A
3	16013-ZA0-931	FLOAT SET .....	1	-	-	-----	LWD1,LWD1/A
4	16015-ZE2-A20	CHAMBER SET, FLOAT .....	1	-	-	-----	LWD1,LWD1/A
5	16016-ZH7-W01	SCREW SET, PILOT .....	1	-	-	-----	LWD1,LWD1/A
6	16024-ZH7-A20	SCREW SET, DRAIN .....	1	-	-	-----	LWD1,LWD1/A
7	16028-ZE0-005	SCREW SET .....	1	-	-	-----	LWD1,LWD1/A
8	16100-ZE3-H61	CARBURETOR ASSY. (BE80E A) ..	1	-	-	-----	LWD1,LWD1/A
9	16124-ZE0-005	SCREW, THROTTLE STOP .....	1	-	-	-----	LWD1,LWD1/A
10	16148-141-881	CAP, CHOKE DUST .....	1	-	-	-----	LWD1,LWD1/A
11	16166-ZE3-H61	NOZZLE, MAIN .....	1	-	-	-----	LWD1,LWD1/A
12	16172-ZE3-W10	COLLAR, SETTING .....	1	-	-	-----	LWD1,LWD1/A
13	16173-001-004	PACKING, FUEL STRAINER CUP ..	1	-	-	-----	LWD1,LWD1/A
14	16211-ZE3-000	INSULATOR, CARBURETOR .....	1	-	-	-----	LWD1,LWD1/A
15	16221-ZE3-800	PACKING, CARBURETOR .....	1	-	-	-----	LWD1,LWD1/A
16	16223-ZE3-W00	PACKING, INSULATOR .....	1	-	-	-----	LWD1,LWD1/A
17	16252-ZA1-010	CAP, CHOKE LEVER .....	1	-	-	-----	LWD1,LWD1/A
18	16264-ZE2-780	ROD, CHOKE .....	1	-	-	-----	LWD1,LWD1/A
19	16562-896-000	SPRING, THROTTLE RETURN .....	1	-	-	-----	LWD1,LWD1/A
20	16590-ZE2-772	STAY ASSY., CHOKE CONTROL (REMOTE)	1	-	-	-----	LWD1,LWD1/A
21	16610-ZE2-780	LEVER, CHOKE .....	1	-	-	-----	LWD1,LWD1/A
22	16617-ZE3-H00	HOLDER, WIRE .....	1	-	-	-----	LWD1,LWD1/A
23	16953-ZE1-712	LEVER, COCK .....	1	-	-	-----	LWD1,LWD1/A

2

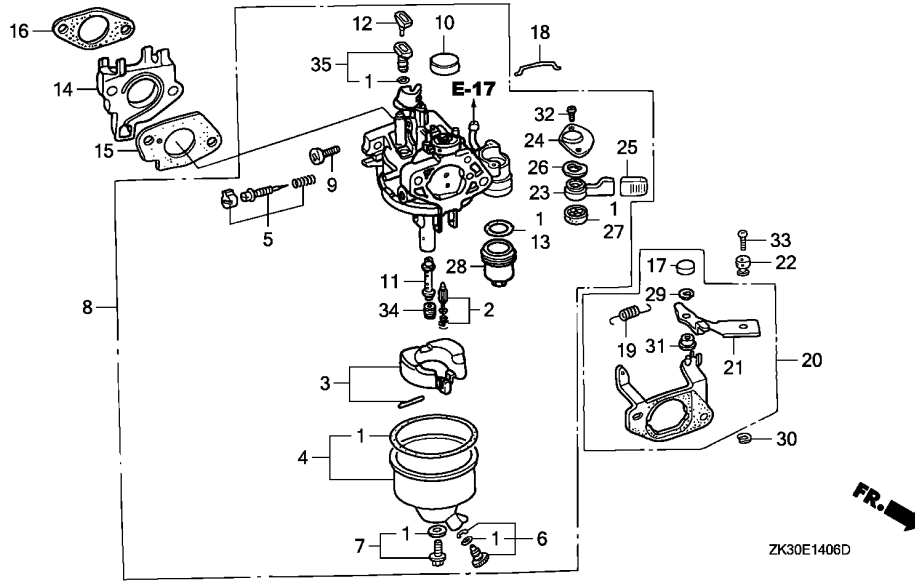

ZK30E1406D

Ref. No.	Part No.	Description	Reqd. QTY			Serial No.	Parts catalogue code
			GX	340K1			
			(1)	(2)	(3)		
24	16954-ZE1-812	PLATE, LEVER SETTING .....	1	-	-	-----	LWD1,LWD1/A
25	16955-ZE2-H21	CAP, LEVER .....	1	-	-	-----	LWD1,LWD1/A
26	16956-ZE1-811	SPRING, COCK LEVER .....	1	-	-	-----	LWD1,LWD1/A
27	16957-ZE1-812	PACKING, FUEL COCK .....	1	-	-	-----	LWD1,LWD1/A
28	16967-ZE0-811	CUP, FUEL STRAINER .....	1	-	-	-----	LWD1,LWD1/A
29	38689-680-960	E-RING, 4MM .....	1	-	-	-----	LWD1,LWD1/A
30	90605-230-000	CIRCLIP, 5MM .....	1	-	-	-----	LWD1,LWD1/A
31	91502-ZA0-310	BUSH, CHOKE LEVER .....	1	-	-	-----	LWD1,LWD1/A
32	93500-03006-1H	SCREW, PAN, 3X6 .....	2	-	-	-----	LWD1,LWD1/A
33	93500-04006-0H	SCREW, PAN, 4X6 .....	1	-	-	-----	LWD1,LWD1/A
34	99101-ZH8-0920	JET, MAIN, #92 .....	(1)	-	-	-----	LWD1,LWD1/A
	99101-ZH8-0950	JET, MAIN, #95 .....	(1)	-	-	-----	LWD1,LWD1/A
	99101-ZH8-0980	JET, MAIN, #98 .....	1	-	-	-----	LWD1,LWD1/A
35	99204-ZE0-0350	JET SET, PILOT, #35 .....	1	-	-	-----	LWD1,LWD1/A



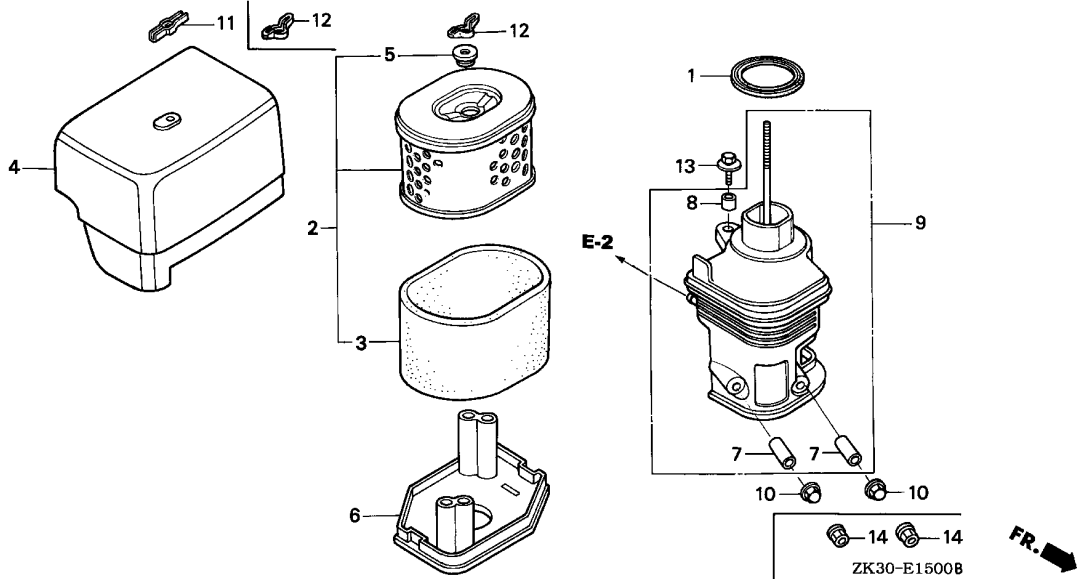

Ref. No.	L.O.N.	(Relative ref. Number) Description	F.R.T.
1	3121E1	PACKING, ELBOW .....	0.1
2	3121B8	ELEMENT, AIR CLEANER .....	0.1
.INCLUDES: Air cleaner- inspection			
3	3121C1	FILTER, OUTER .....	0.1
6	3121D6	NOSE, SILENCER .....	0.1
9	3121B4	ELBOW, AIR CLEANER .....	0.1



Ref. No.	Part No.	Description	Reqd. QTY			Serial No.	Parts catalogue code
			GX	(1)	(2)		
1	16271-ZE2-010	PACKING, ELBOW .....	1	-	-	-----	BJ, EDK, EDN5, EDN5/A, ED7, ED8, ED8/A, ED9, ED9/A, EN, ES, ES1, ES1/A, ES2, ET, ETS, ETX, HA, HAQ, HA2, HA2/A, HH, HX, HX2, HX26, HX26/A, LH, LH/A, LHB1, LHB3, LHB3/A, LHB5, LHE, LHE/A, LHQ4, LHQ4/A, LJ, LJ/A, LJG, LJG/A, LJS1, LKE, LKE/A, LSX, LWD, LX, LX/A, LXE, LXE/A, LXE2, LXE2/A, LXE4, LXE4/A, LXE6, LXE8, LXE8/A, LXQ4, LXQ4/A, LXU, LXU/A, LXZ, LXZ, LXZ/A, LXZ6, LXZ6/A, PKT2, PKT2/A, PKT4, PKT4/A, PKX2, PKX4, PKX4/A, PX, PX/A, PXE8, PXE8/A, QA, QAB2, QAB2/A, QAC2, QAC2/A, QAE, QAE2, QAE2/A, QAE6, QAE6/A, QAG, QAG/A, QAH2, QAH2/A, QAP, QAPE, QAP2, QAP2/A, QAQ, QA2, QA2/A, QA26, QA26/A, QE, QE/A, QH, QH/A, QHB3, QHB3/A, QHB5, QHE, QHE/A, QHP1, QHP1/A, QHQ4, QHQ4/A, QHZ, QKA4, QKA4/A, QL2, QMED, QMED/A, QME8, QME8/A, QMH, QMH/A, QMT2, QMT2/A, QMX2, QNE, QNE2, QNE2/A, QNE6, QNE9, QNE9/A, QNR2, QNR2/A, QNR6, QNR6/A, QN18, QPE2, QTC2, QTC2/A, QX, QX/A, QXB, QXB/A, QXB7, QXB7/A, QXE, QXE/A, QXEB, QXE2, QXE4, QXE4/A, QXE6, QXE6/A, QXE8, QXE8/A, QXQ4, QXQ4/A, QXU, QXU/A, QX2, SDE, SE, SE/A, SH, SH/A, SHB1, SHB3, SHB3/A, SHE, SHEZ, SHQ4, SHQ4/A, SJ, SJ/A, SJG, SJG/A, SKE, SKE/A, SKZ, SKZ/A, SMEO, SMEO/A, SME2, SMX2, SMX2/A, STJ, STJ/A, STP, STP/A, STQ, STQ/A, STR, STR/A, SX, SX/A, SXB, SXB/A, SXB7, SXB7/A, SXE, SXE/A, SXEB, SXEB/A, SXE2, SXE4, SXE4/A, SXE8, SXE8/A, SXP, SXQ4, SXQ4/A, SXU, SXU/A, VA, VAA, VAAE, VAD2, VAD2/A, VAH1, VAH2, VAW1, VA2, VA2/A, VDE, VDE2, VDE2/A, VD16, VE, VEB6, VH, VHE, VH12, VH12/A, VH22, VH22/A, VMX, VNG, VNG1, VNG2, VSH7, VWA, VWA2, VWC2, VWC2/A, VWE2, VWE2/A, VWS2, VWS2/A, VW12, VW12/A, VX, VX/A, VXA, VXB, VXB/A, VXB2, VXB7, VXB7/A, VXE, VXE/A, VXEB, VXEB/A, VXE2, VXE2/A, VXE4, VXE6, VXE7, VXE7/A, VXE8, VXE8/A, VXG, VXK, VXQ4, VXQ4/A, VXU, VXU/A, VXU1, VXU1/A, VX16, VX16/A, VX8, VX8/A, YJ
			-	(1)	1		

Ref. No.	Part No.	Description	Reqd. QTY			Serial No.	Parts catalogue code
			(1)	(2)	(3)		
2	17210-ZE3-010	ELEMENT, AIR CLEANER .....	1	-	-	-----	BJ,EDK,EDN5,EDN5/A,ED7,ED8,ED8/A,ED9,ED9/A,EN,ES,ES1,ES1/A,ES2,ET ETS,ETX,HA,HAQ,HA2,HA2/A,HH,HX,HX2,HX26,HX26/A,LH,LH/A,LHB1,LHB3 LHB3/A,LHB5,LHE,LHE/A,LHQ4,LHQ4/A,LJ,LJ/A,LJG,LJG/A,LJS1,LKE LKE/A,LSX,LWD,LX,LX/A,LXE,LXE/A,LXE2,LXE2/A,LXE4,LXE4/A,LXE6,LXE8 LXE8/A,LXQ4,LXQ4/A,LXU,LXU/A,LXZ,LX2,LX2/A,LX26,LX26/A,PKT2 PKT2/A,PKT4,PKT4/A,PKX2,PKX4,PKX4/A,PX,PX/A,PXE8,PXE8/A,QA,QAB2 QAB2/A,QAC2,QAC2/A,QAE,QAE2,QAE2/A,QAE6,QAE6/A,QAG,QAG/A,QAQ2 QAQ2/A,QAP,QAPE,QAP2,QAP2/A,QAQ,QA2,QA2/A,QA26,QA26/A,QE,QE/A,QH QH/A,QHB3,QHB3/A,QHB5,QHE,QHE/A,QHP1,QHP1/A,QHQ4,QHQ4/A,QH2,QKA4 QKA4/A,QL2,QMEO,QMEO/A,QME8,QME8/A,QMH,QMH/A,QMT2,QMT2/A,QMX2,QNE QNE2,QNE2/A,QNE6,QNE9,QNE9/A,QNR2,QNR2/A,QNR6,QNR6/A,QN18,QPE2 QTC2,QTC2/A,QX,QX/A,QXB,QXB/A,QXB7,QXB7/A,QXE,QXE/A,QXEB,QXE2 QXE4,QXE4/A,QXE6,QXE6/A,QXE8,QXE8/A,QXQ4,QXQ4/A,QXU,QXU/A,QX2,SDE SE,SE/A,SH,SH/A,SHB1,SHB3,SHB3/A,SHE,SHEZ,SHQ4,SHQ4/A,SJ,SJ/A,SJG SJG/A,SKE,SKE/A,SKZ,SKZ/A,SME0,SME0/A,SME2,SMX2,SMX2/A,STJ,STJ/A STP,STP/A,STQ,STQ/A,STR,STR/A,SX,SX/A,SBX,SBX/A,SBX7,SBX7/A,SXE SXE/A,SXEB,SXEB/A,SXE2,SXE4,SXE4/A,SXE8,SXE8/A,SXP,SXQ4,SXQ4/A SXU,SXU/A,VA,VAA,VAE,VAD2,VAD2/A,VAH1,VAH2,VAW1,VA2,VA2/A,VDE VDE2,VDE2/A,VD16,VE,VEB6,VH,VHE,VH12,VH12/A,VH22,VH22/A,VMX,VNG VNG1,VNG2,VSH7,VWA,VWA2,VWC2,VWC2/A,VWE2,VWE2/A,VWS2,VWS2/A,VW12 VW12/A,VX,VX/A,VXA,VXB,VXB/A,VXB2,VXB7,VXB7/A,VXE,VXE/A,VXEB VXEB/A,VXE2,VXE2/A,VXE4,VXE6,VXE7,VXE7/A,VXE8,VXE8/A,VXG,VXK,VXQ4 VXQ4/A,VXU,VXU/A,VXU1,VXU1/A,VX16,VX16/A,VX8,VX8/A,YJ
3	17218-ZE3-000	FILTER, OUTER .....	1	-	(1) 1	-----	BJ,EDK,EDN5,EDN5/A,ED7,ED8,ED8/A,ED9,ED9/A,EN,ES,ES1,ES1/A,ES2,ET ETS,ETX,HA,HAQ,HA2,HA2/A,HH,HX,HX2,HX26,HX26/A,LH,LH/A,LHB1,LHB3 LHB3/A,LHB5,LHE,LHE/A,LHQ4,LHQ4/A,LJ,LJ/A,LJG,LJG/A,LJS1,LKE LKE/A,LSX,LWD,LX,LX/A,LXE,LXE/A,LXE2,LXE2/A,LXE4,LXE4/A,LXE6,LXE8 LXE8/A,LXQ4,LXQ4/A,LXU,LXU/A,LXZ,LX2,LX2/A,LX26,LX26/A,PKT2 PKT2/A,PKT4,PKT4/A,PKX2,PKX4,PKX4/A,PX,PX/A,PXE8,PXE8/A,QA,QAB2 QAB2/A,QAC2,QAC2/A,QAE,QAE2,QAE2/A,QAE6,QAE6/A,QAG,QAG/A,QAQ2 QAQ2/A,QAP,QAPE,QAP2,QAP2/A,QAQ,QA2,QA2/A,QA26,QA26/A,QE,QE/A,QH QH/A,QHB3,QHB3/A,QHB5,QHE,QHE/A,QHP1,QHP1/A,QHQ4,QHQ4/A,QH2,QKA4 QKA4/A,QL2,QMEO,QMEO/A,QME8,QME8/A,QMH,QMH/A,QMT2,QMT2/A,QMX2,QNE QNE2,QNE2/A,QNE6,QNE9,QNE9/A,QNR2,QNR2/A,QNR6,QNR6/A,QN18,QPE2 QTC2,QTC2/A,QX,QX/A,QXB,QXB/A,QXB7,QXB7/A,QXE,QXE/A,QXEB,QXE2 QXE4,QXE4/A,QXE6,QXE6/A,QXE8,QXE8/A,QXQ4,QXQ4/A,QXU,QXU/A,QX2,SDE SE,SE/A,SH,SH/A,SHB1,SHB3,SHB3/A,SHE,SHEZ,SHQ4,SHQ4/A,SJ,SJ/A,SJG SJG/A,SKE,SKE/A,SKZ,SKZ/A,SME0,SME0/A,SME2,SMX2,SMX2/A,STJ,STJ/A STP,STP/A,STQ,STQ/A,STR,STR/A,SX,SX/A,SBX,SBX/A,SBX7,SBX7/A,SXE SXE/A,SXEB,SXEB/A,SXE2,SXE4,SXE4/A,SXE8,SXE8/A,SXP,SXQ4,SXQ4/A SXU,SXU/A,VA,VAA,VAE,VAD2,VAD2/A,VAH1,VAH2,VAW1,VA2,VA2/A,VDE VDE2,VDE2/A,VD16,VE,VEB6,VH,VHE,VH12,VH12/A,VH22,VH22/A,VMX,VNG VNG1,VNG2,VSH7,VWA,VWA2,VWC2,VWC2/A,VWE2,VWE2/A,VWS2,VWS2/A,VW12 VW12/A,VX,VX/A,VXA,VXB,VXB/A,VXB2,VXB7,VXB7/A,VXE,VXE/A,VXEB VXEB/A,VXE2,VXE2/A,VXE4,VXE6,VXE7,VXE7/A,VXE8,VXE8/A,VXG,VXK,VXQ4 VXQ4/A,VXU,VXU/A,VXU1,VXU1/A,VX16,VX16/A,VX8,VX8/A,YJ



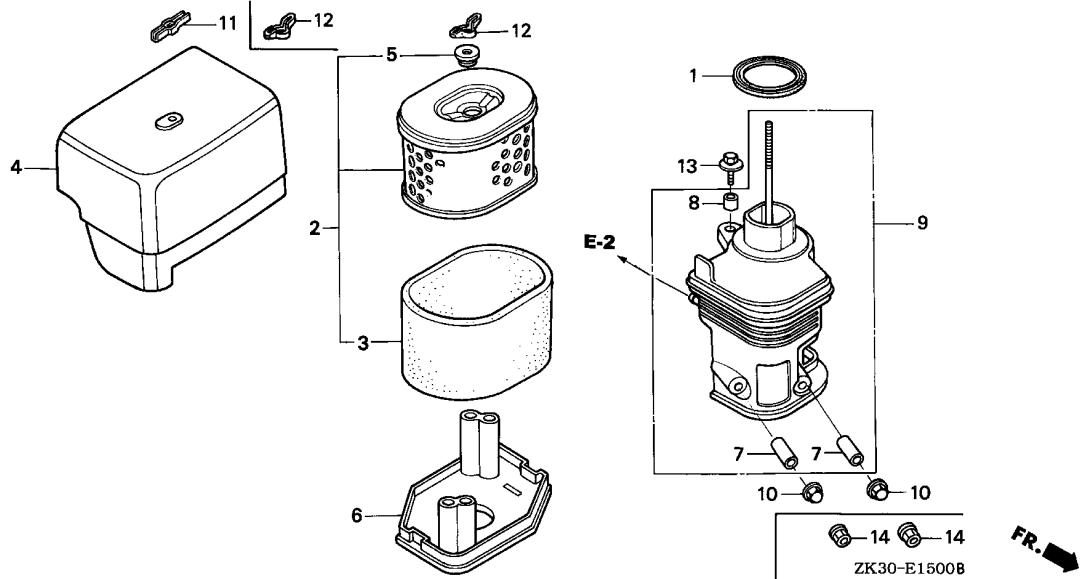

Ref. No.	Part No.	Description	Reqd. QTY			Serial No.	Parts catalogue code
			GX	340K1			
			(1)	(2)	(3)		
4	17231-ZE3-W00	COVER, AIR CLEANER .....	1	(1)	-	-----	BJ, ED7, EN, ES, ET, ETS, ETX, HA, HAQ, HH, HX, HX2, LHB1, LSX, LXE6, LXZ, QA, QAE, QAP, QAPE, QAAQ, QH2, QL2, QMX2, QNE, QNE6, QN18, QPE2, QXEB, QXE2, QX2, SDE, SHB1, SHE, SHEZ, SME2, SXE2, SXP, VA, VAA, VAAE, VAH1, VAH2, VAW1, VDE, VD16, VE, VEB6, VH, VHE, VMX, VNG, VNG1, VNG2, VWA, VWA2, VXA, VXB2, VXE4, VXE6, VVG, V1, YJ
			1	(1)	-	-----	3394504 EDN5, ED8, ED9, ES1, HA2, HX26, LH, LHB3, LHE, LHQ4, LJ, LJG, LKE, LX, LXE, LXE2, LXE4, LXE8, LXQ4, LXU, LX2, LX26, L1, PKT2, PKT4, PKX4, PX, PXE8, P1, QAB2, QAC2, QAE2, QAE6, QAH2, QAP2, QA2, QA26, QE, QH, QHB3, QHE, QHP1, QHQ4, QKA4, QMED, QME8, QMH, QMT2, QNE2, QNE9, QNR2, QNR6, QTC2, QX, QXB, QXE, QXE4, QXE6, QXE8, QXQ4, QXU, Q1, SE, SH, SHB3, SHQ4, SJ, SJG, SKE, SKZ, SMED, SMX2, STJ, STP, STQ, STR, SX, SXB, SXE, SXEB, SXE4, SXE8, SXQ4, SXU, S1, VAD2, VA2, VDE2, VH12, VH22, VWC2, VWE2, VWS2, VW12, VX, VXB, VXE, VXEB, VXE2, VXE8, VXQ4, VXU, VXU1, VX16, VX8
			-	-	1		



Ref. No.	Part No.	Description	Reqd. QTY			Serial No.	Parts catalogue code
			GX 340K1 (1)	(2)	(3)		
(4)	17231-ZE3-W01	COVER, AIR CLEANER .....	1	(1)	-	-----	EDK,EDN5/A,ED8/A,ED9/A,ES1/A,ES2,HA2/A,HX26/A,LH/A,LHB3/A,LHB5 LHE/A,LHQ4/A,LJ/A,LJG/A,LJS1,LKE/A,LWD,LX/A,LXE/A,LXE2/A,LXE4/A LXE8/A,LXQ4/A,LXU/A,LX2/A,LX26/A,L1/A,PKT2/A,PKT4/A,PKX2,PKX4/A PX/A,PXE8/A,P1/A,QAB2/A,QAC2/A,QAE2/A,QAE6/A,QAG,QAG/A,QA2/A QAH2/A QAP2/A,QA2/A,QA26/A,QE/A,QH/A,QHB3/A,QHB5,QHE/A,QHP1/A,QHQ4/A QKA4/A,QME0/A,QME8/A,QMH/A,QMT2/A,QNE2/A,QNE9/A,QNR2/A,QNR6/A QTC2/A,QX/A,QXB/A,QXB7/A,QXE/A,QXE4/A,QXE6/A,QXE8/A,QXQ4/A QXU/A,Q1/A,SE/A,SH/A,SHB3/A,SHQ4/A,SJ/A,SJG/A,SKE/A,SKZ/A,SMEO/A SMX2/A,STJ/A,STP/A,STQ/A,STR/A,SX/A,SXB/A,SXB7/A,SXE/A SXEB/A,SXE4/A,SXE8/A,SXQ4/A,SXU/A,S1/A,VAD2/A,VA2/A,VDE2/A,VH12/A VH22/A,VSH7,VWC2/A,VWE2/A,VWS2/A,VW12/A,VX/A,VXB/A,VXB7/VXB7/A VXE/A,VXEB/A,VXE2/A,VXE7,VXE7/A,VXE8/A,VXK,VXQ4/A,VXU/A,VXU1/A VX16/A,VX8/A
			1	(1)	-	3394505 -----	EDN5,ED8,ED9,ES1,HA2,HX26,LH,LHB3,LHE,LHQ4,LJ,LJG,LKE,LX,LXE,LXE2 LXE4,LXE8,LXQ4,LXU,LX2,LX26,L1,PKT2,PKT4,PKX4,PX,PXE8,P1,QAB2 QAC2,QAE2,QAE6,QAH2,QAP2,QA2,QA26,QE,QH,QHB3,QHE,QHP1,QHQ4,QKA4 QME0,QME8,QMH,QMT2,QNE2,QNE9,QNR2,QNR6,QTC2,QX,QXB,QXE,QXE4,QXE6 QXE8,QXQ4,QXU,Q1,SE,SH,SHB3,SHQ4,SJ,SJG,SKE,SKZ,SMEO,SMX2,STJ,STP STQ,STR,SX,SXB,SXE,SXEB,SXE4,SXE8,SXQ4,SXU,S1,VAD2,A,VA2,VDE2,VH12 VH22,VWC2,VWE2,VWS2,VW12,VX,VXB,VXE,VXEB,VXE2,VXE8,VXQ4,VXU,VXU1 VX16,VX8
5	17232-891-000	GROMMET, AIR CLEANER .....	1	-	-	-----	BJ,EDK,EDN5,EDN5/A,ED7,ED8,ED8/A,ED9,ED9/A,EN,ES,ES1,ES1/A,ES2,ET ETS,ETX,HA,HAQ,HA2,HA2/A,HH,HX,HX2,HX26,HX26/A,LH,LH/A,LHB1,LHB3 LHB3/A,LHB5,LHE,LHE/A,LHQ4,LHQ4/A,LJ,LJ/A,LJG,LJG/A,LJS1,LKE LKE/A,LSX,LWD,LX,LX/A,LXE,LXE/A,LXE2,LXE2/A,LXE4,LXE4/A,LXE6,LXE8 LXE8/A,LXQ4,LXQ4/A,LXU,LXU/A,LXZ,LX2,LX2/A,LX26,LX26/A,PKT2 PKT2/A,PKT4,PKT4/A,PKX2,PKX4,PKX4/A,PX,PX/A,PXE8,PXE8/A,QA,QAB2 QAB2/A,QAC2,QAC2/A,QAE,QAE2,QAE2/A,QAE6,QAE6/A,QAG,QAG/A,QAH2 QAH2/A,QAP,QAPE,QAP2,QAP2/A,QAQ,QA2,QA2/A,QA26,QA26/A,QE,QE/A,QH QH/A,QHB3,QHB3/A,QHB5,QHE,QHE/A,QHP1,QHP1/A,QHQ4,QHQ4/A,QHZ,QKA4 QKA4/A,QL2,QME0,QME0/A,QME8,QME8/A,QMH,QMH/A,QMT2,QMT2/A,QMX2,QNE QNE2,QNE2/A,QNE6,QNE9,QNE9/A,QNR2,QNR2/A,QNR6,QNR6/A,QN18,QPE2 QTC2,QTC2/A,QX,QX/A,QXB,QXB/A,QXB7,QXB7/A,QXE,QXE/A,QXEB,QXE2 QXE4,QXE4/A,QXE6,QXE6/A,QXE8,QXE8/A,QXQ4,QXQ4/A,QXU,QXU/A,QX2,SDE SE,SE/A,SH,SH/A,SHB1,SHB3,SHB3/A,SHE,SHEZ,SHQ4,SHQ4/A,SJ,SJ/A,SJG SJG/A,SKE,SKE/A,SKZ,SKZ/A,SMEO,SMEO/A,SME2,SMX2,SMX2/A,STJ,STJ/A STP,STP/A,STQ,STQ/A,STR,STR/A,SX,SX/A,SXB,SXB/A,SXB7,SXB7/A,SXE SXE/A,SXEB,SXEB/A,SXE2,SXE4,SXE4/A,SXE8,SXE8/A,SXP,SXQ4,SXQ4/A SXU,SXU/A,VA,VAA,VAAE,VAD2,VAD2/A,VAH1,VAH2,VAW1,VA2,VA2/A,VDE VDE2,VDE2/A,VD16,VE,VEB6,VH,VHE,VH12,VH12/A,VH22,VH22/A,VMX,VNG VNG1,VNG2,VSH7,VWA,VWA2,VWC2,VWC2/A,VWE2,VWE2/A,VWS2,VWS2/A,VW12 VW12/A,VX,VX/A,VXA,VXB,VXB/A,VXB2,VXB7,VXB7/A,VXE,VXE/A,VXEB VXEB/A,VXE2,VXE2/A,VXE4,VXE6,VXE7,VXE7/A,VXE8,VXE8/A,VXG,VXK,VXQ4 VXQ4/A,VXU,VXU/A,VXU1,VXU1/A,VX16,VX16/A,VX8,VX8/A,YJ
			-	(1)	1		



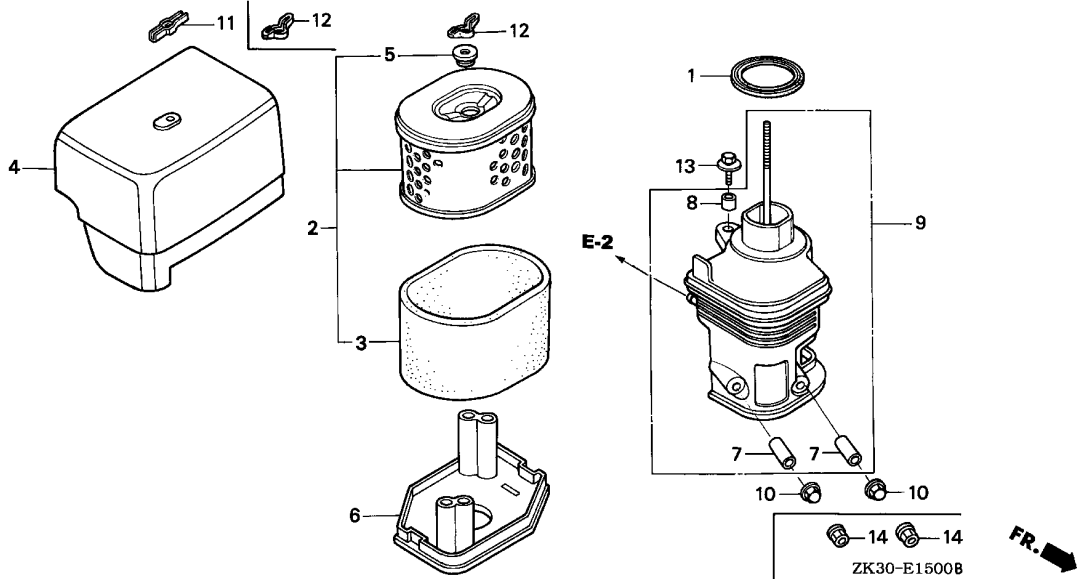

Ref. No.	Part No.	Description	Reqd. QTY			Serial No.	Parts catalogue code
			GX	(1)	(2)		
6	17235-ZH9-N00	NOSE, SILENCER .....	1	(1)	-	BJ, EDN5, ED7, ED8, ED9, EN, ES, ES1, ET, ETS, ETX, HA, HAQ, HA2, HH, HX, HX2, HX26, LH, LHB1, LHB3, LHE, LHQ4, LJ, LJG, LKE, LSX, LX, LXE, LXE2, LXE4, LXE6, LXE8, LXQ4, LXU, LXZ, LX2, LX26, L1, PKT2, PKT4, PKX4, PX, PXE8, P1, QA, QAB2, QAC2, QAE, QAE2, QAE6, QAG, QAH2, QAP, QAPE, QAP2, QAQ, QA2, QA26, QE, QH, QHB3, QHE, QHP1, QHQ4, QH2, QKA4, QL2, QMEO, QME8, QMH, QMT2, QMX2, QNE, QNE2, QNE6, QNE9, QNR2, QNR6, QN18, QPE2, QTC2, QX, QXB, QXB7, QXE, QXEB, QXE2, QXE4, QXE6, QXE8, QXQ4, QXU, QX2, Q1, SDE, SE, SH, SHB1, SHB3, SHE, SHE2, SHQ4, SJ, SJG, SKE, SKZ, SMEO, SME2, SMX2, STJ, STP, STQ, STR, SX, SXB, SXB7, SXE, SXEB, SXE2, SXE4, SXE8, SXP, SXQ4, SXU, S1, VA, VAA, VAAE, VAD2, VAH1, VAH2, VAW1, VA2, VDE, VDE2, VD16, VE, VEB6, VH, VHE, VH12, VH22, VMX, VNG, VNG1, VNG2, VWA, VWA2, VWC2, VWE2, VWS2, VW12, VX, VXA, VXB, VXB2, VXB7, VXE, VXEB, VXE2, VXE4, VXE6, VXE7, VXE8, VVG, VXQ4, VXU, VXU1, VX16, VX8, V1, YJ	
			1	(1)	-	3980460	EDN5/A, ED8/A, ED9/A, ES1/A, HA2/A, HX26/A, LH/A, LHB3/A, LHB5, LHE/A, LHQ4/A, LJ/A, LJG/A, LJS1, LKE/A, LWD, LX/A, LXE/A, LXE2/A, LXE4/A, LXE8/A, LXQ4/A, LXU/A, LX2/A, LX26/A, L1/A, PKT2/A, PKT4/A, PKX2, PKX4/A, PX/A, PXE8/A, P1/A, QAB2/A, QAC2/A, QAE2/A, QAE6/A, QAG/A, QAH2/A, QAP2/A, QA2/A, QA26/A, QE/A, QH/A, QHB3/A, QHB5, QHE/A, QHP1/A, QHQ4/A, QKA4/A, QMEO/A, QME8/A, QMH/A, QMT2/A, QNE2/A, QNE9/A, QNR2/A, QNR6/A, QTC2/A, QX/A, QXB/A, QXB7/A, QXE/A, QXE4/A, QXE6/A, QXE8/A, QXQ4/A, QXU/A, Q1/A, SE/A, SH/A, SHB3/A, SHQ4/A, SJ/A, SJG/A, SKE/A, SKZ/A, SMEO/A, SMX2/A, STJ/A, STP/A, STQ/A, STR/A, SX/A, SXB/A, SXB7/A, SXE/A, SXEB/A, SXE4/A, SXE8/A, SXQ4/A, SXU/A, S1/A, VAD2/A, VA2/A, VDE2/A, VH12/A, VH22/A, VSH7, VWC2/A, VWE2/A, VWS2/A, VW12/A, VX/A, VXB/A, VXB7/A, VXE/A, VXEB/A, VXE2/A, VXE7/A, VXE8/A, VXQ4/A, VXU/A, VXU1/A, VX16/A, VX8/A
			-	-	-	1	

Ref. No.	Part No.	Description	Reqd. QTY			Serial No.	Parts catalogue code
			(1)	(2)	(3)		
(6)	17235-ZH9-N01	NOSE, SILENCER .....	1	(1)	-	3980461 -----	EDN5/A,ED8/A,ED9/A,ES1/A,HA2/A,HX26/A,LH/A,LHB3/A,LHB5,LHE/A,LHQ4/A,LJ/A,LJG/A,LJS/A,LJS1,LKE/A,LWD,LX/A,LXE/A,LXE2/A,LXE4/A,LXE8/A,LXQ4/A,LXU/A,LX2/A,LX26/A,L1/A,PKT2/A,PKT4/A,PKX2,PKX4/A,PX/A,PXE8/A,P1/A,QAB2/A,QAC2/A,QAE2/A,QAE6/A,QAG/A,QAQ2/A,QAP2/A,QA2/A,QA26/A,QA/A,QH/A,QHB3/A,QHB5,QHE/A,QHP1/A,QHQ4/A,QKA4/A,QME0/A,QME8/A,QMH/A,QMT2/A,QNE2/A,QNE9/A,QNR2/A,QNR6/A,QTC2/A,QX/A,QXB/A,QXB7/A,QXE/A,QXE4/A,QXE6/A,QXE8/A,QXQ4/A,QXU/A,Q1/A,SE/A,SH/A,SHB3/A,SHQ4/A,SJ/A,SJG/A,SKE/A,SKZ/A,SMEO/A,SMX2/A,STJ/A,STP/A,STQ/A,STR/A,SX/A,SXB/A,SXB7/A,SXE/A,SXB7/A,SXE4/A,SXE8/A,SXQ4/A,SXU/A,S1/A,VAD2/A,VA2/A,VDE2/A,VH12/A,VH22/A,VSH7,VWC2/A,VWE2/A,VWS2/A,VW12/A,VX/A,VXB/A,VXB7/A,VXE/A,VXEB/A,VXE2/A,VXE7/A,VXE8/A,VXQ4/A,VXU/A,VXU1/A,VX16/A,VX8/A
			1	-	-	-----	EDK,ES2,VXK
7	17238-ZE2-310	COLLAR, AIR CLEANER .....	2	-	-	-----	BJ,EDK,EDN5,EDN5/A,ED7,ED8,ED8/A,ED9,ED9/A,EN,ES,ES1,ES1/A,ES2,ET,ETS,ETX,HA,HAQ,HA2,HA2/A,HH,HX,HX2,HX26,HX26/A,LH,LH/A,LHB1,LHB3,LHB3/A,LHB5,LHE,LHE/A,LHQ4,LHQ4/A,LJ,LJ/A,LJG,LJG/A,LJS1,LKE,LKE/A,LSX,LWD,LX,LX/A,LXE,LXE/A,LXE2,LXE2/A,LXE4,LXE4/A,LXE6,LXE8,LXE8/A,LXQ4,LXQ4/A,LXU,LXU/A,LXZ,LX2,LX2/A,LX26,LX26/A,PKT2,PKT2/A,PKT4,PKT4/A,PKX2,PKX4,PKX4/A,PX,PX/A,PXE8,PXE8/A,QA,QAB2,QAB2/A,QAC2,QAC2/A,QAE,QAE2,QAE2/A,QAE6,QAE6/A,QAG,QAG/A,QAQ2,QAQ2/A,QAP,QAPE,QAP2,QAP2/A,QAQ,QA2,QA2/A,QA26,QA26/A,QAQ,QA/A,QH,QH/A,QHB3,QHB3/A,QHB5,QHE,QHE/A,QHP1,QHP1/A,QHQ4,QHQ4/A,QH2,QKA4,QKA4/A,QL2,QME0,QME0/A,QME8,QME8/A,QMH,QMH/A,QMT2,QMT2/A,QMX2,QNE,QNE2,QNE2/A,QNE6,QNE9,QNE9/A,QNR2,QNR2/A,QNR6,QNR6/A,QN18,QPE2,QTC2,QTC2/A,QX,QX/A,QXB,QXB/A,QXB7,QXB7/A,QXE,QXE/A,QXEB,QXE2,QXE4,QXE4/A,QXE6,QXE6/A,QXE8,QXE8/A,QXQ4,QXQ4/A,QXU,QXU/A,QX2,SDE,SE,SE/A,SH,SH/A,SHB1,SHB3,SHB3/A,SHE,SHEZ,SHQ4,SHQ4/A,SJ,SJ/A,SJG,SJG/A,SKE,SKE/A,SKZ,SKZ/A,SMEO,SMEO/A,SME2,SMX2,SMX2/A,STJ,STJ/A,STP,STP/A,STQ,STQ/A,STR,STR/A,SX,SX/A,SXB,SXB/A,SXB7,SXB7/A,SXE,SXE/A,SXEB,SXEB/A,SXE2,SXE4,SXE4/A,SXE8,SXE8/A,SXP,SXQ4,SXQ4/A,SXU,SXU/A,VA,VAA,VAAE,VAD2,VAD2/A,VAH1,VAH2,VAW1,VA2,VA2/A,VDE,VDE2,VDE2/A,VD16,VE,VEB6,VH,VHE,VH12,VH12/A,VH22,VH22/A,VMX,VNG,VNG1,VNG2,VSH7,VWA,VWA2,VWC2,VWC2/A,VWE2,VWE2/A,VWS2,VWS2/A,VW12,VW12/A,VX,VX/A,VXA,VXB,VXB/A,VXB2,VXB7,VXB7/A,VXE,VXE/A,VXEB,VXEB/A,VXE2,VXE2/A,VXE4,VXE6,VXE7,VXE7/A,VXE8,VXE8/A,VXG,VXK,VXQ4,VXQ4/A,VXU,VXU/A,VXU1,VXU1/A,VX16,VX16/A,VX8,VX8/A,YJ
			-	(2)	2		



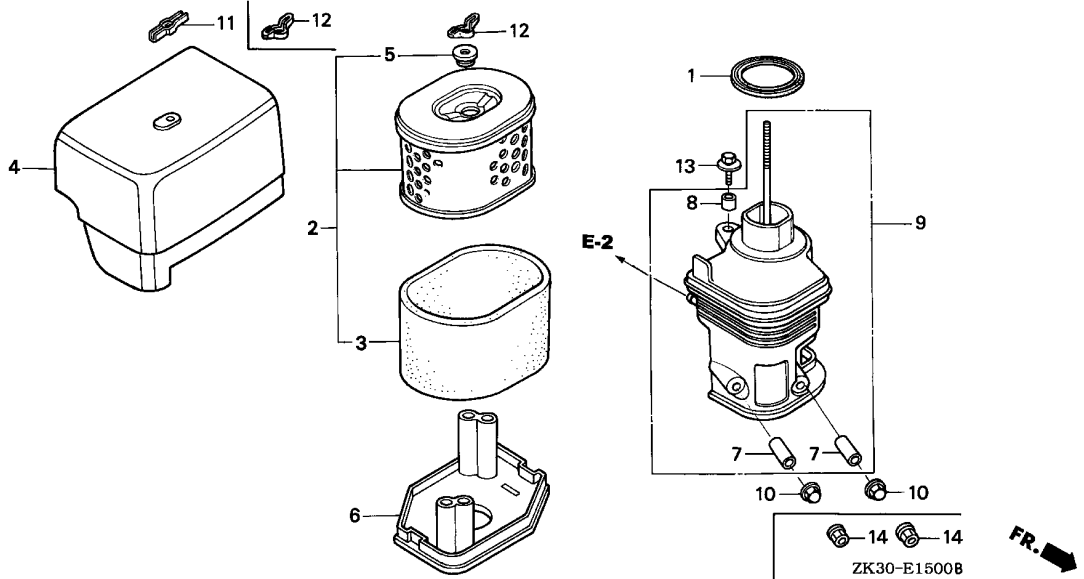

Ref. No.	Part No.	Description	Reqd. QTY			Serial No.	Parts catalogue code
			GX	(1)	(2)		
8	17239-ZE1-000	COLLAR B, AIR CLEANER .....	1	-	-	-----	BJ,EDK,EDN5,EDN5/A,ED7,ED8,ED8/A,ED9,ED9/A,EN,ES,ES1,ES1/A,ES2,ETS,ETX,HA,HAQ,HA2,HA2/A,HH,HX,HX2,HX26,HX26/A,LH,LH/A,LHB1,LHB3,LHB3/A,LHB5,LHE,LHE/A,LHQ4,LHQ4/A,LJ,LJ/A,LJG,LJG/A,LJS1,LKE,LKE/A,LSX,LWD,LX,LX/A,LXE,LXE/A,LXE2,LXE2/A,LXE4,LXE4/A,LXE6,LXE8,LXE8/A,LXQ4,LXQ4/A,LXU,LXU/A,LXZ,LX2,LX2/A,LX26,LX26/A,PKT2,PKT2/A,PKT4,PKT4/A,PKX2,PKX4,PKX4/A,PX,PX/A,PXE8,PXE8/A,QA,QAB2,QAB2/A,QAC2,QAC2/A,QAE,QAE2,QAE2/A,QAE6,QAE6/A,QAG,QAG/A,QAQ2,QAQ2/A,QAP,QAPE,QAP2,QAP2/A,QAQ,QA2,QA2/A,QA26,QA26/A,QE,QE/A,QH,QH/A,QHB3,QHB3/A,QHB5,QHE,QHE/A,QHP1,QHP1/A,QHQ4,QHQ4/A,QHZ,QKA4,QKA4/A,QL2,QMEO,QMEO/A,QME8,QME8/A,QMH,QMH/A,QMT2,QMT2/A,QMX2,QNE,QNE2,QNE2/A,QNE6,QNE9,QNE9/A,QNR2,QNR2/A,QNR6,QNR6/A,QN18,QPE2,QTC2,QTC2/A,QX,QX/A,QXB,QXB/A,QXB7,QXB7/A,QXE,QXE/A,QXEB,QXE2,QXE4,QXE4/A,QXE6,QXE6/A,QXE8,QXE8/A,QXQ4,QXQ4/A,QXU,QXU/A,QX2,SDE,SE,SE/A,SH,SH/A,SHB1,SHB3,SHB3/A,SHE,SHEZ,SHQ4,SHQ4/A,SJ,SJ/A,SJG,SJG/A,SKE,SKE/A,SKZ,SKZ/A,SMEO,SMEO/A,SME2,SMX2,SMX2/A,STJ,STJ/A,STP,STP/A,STQ,STQ/A,STR,STR/A,SX,SX/A,AXB,AXB/A,AXB7,AXB7/A,SXE,SXE/A,SXEB,SXEB/A,SXE2,SXE4,SXE4/A,SXE8,SXE8/A,SXP,SXQ4,SXQ4/A,SXU,SXU/A,VA,VAA,VAAE,VAD2,VAD2/A,VAH1,VAH2,VAW1,VA2,VA2/A,VDE,VDE2,VDE2/A,VD16,VE,VEB6,VH,VHE,VH12,VH12/A,VH22,VH22/A,VMX,VNG,VNG1,VNG2,VSH7,VWA,VWA2,VWC2,VWC2/A,VWE2,VWE2/A,VWS2,VWS2/A,VW12,VW12/A,VX,VX/A,VXA,VXB,VXB/A,VXB2,VXB7,VXB7/A,VXE,VXE/A,VXEB,VXEB/A,VXE2,VXE2/A,VXE4,VXE6,VXE7,VXE7/A,VXE8,VXE8/A,VXG,VXK,VXQ4,VXQ4/A,VXU,VXU/A,VXU1,VXU1/A,VX16,VX16/A,VX8,VX8/A,YJ
			-	(1)	1		

Ref. No.	Part No.	Description	Reqd. QTY			Serial No.	Parts catalogue code
			(1)	(2)	(3)		
9	17410-ZH9-N00	ELBOW COMP., AIR CLEANER	1	-	-	-----	BJ,EDK,EDN5,EDN5/A,ED7,ED8,ED8/A,ED9,ED9/A,EN,ES,ES1,ES1/A,ES2,ET,ETS,ETX,HA,HAQ,HA2,HA2/A,HH,HX,HX2,HX26,HX26/A,LH,LH/A,LHB1,LHB3,LHB3/A,LHB5,LHE,LHE/A,LHQ4,LHQ4/A,LJ,LJ/A,LJG,LJG/A,LJS1,LKE,LKE/A,LSX,LWD,LX,LX/A,LXE,LXE/A,LXE2,LXE2/A,LXE4,LXE4/A,LXE6,LXE8,LXE8/A,LXQ4,LXQ4/A,LXU,LXU/A,LXZ,LX2,LX2/A,LX26,LX26/A,PKT2,PKT2/A,PKT4,PKT4/A,PKX2,PKX4,PKX4/A,PX,PX/A,PXE8,PXE8/A,QA,QAB2,QAB2/A,QAC2,QAC2/A,QAE,QAE2,QAE2/A,QAE6,QAE6/A,QAG,QAG/A,QA2,QA2/A,QAP,QAPE,QAPE2,QAPE2/A,QAQ,QA2,QA2/A,QA26,QA26/A,QE,QE/A,QH,QH/A,QHB3,QHB3/A,QHB5,QHE,QHE/A,QHP1,QHP1/A,QHQ4,QHQ4/A,QH2,QKA4,QKA4/A,QL2,QMEO,QMEO/A,QME8,QME8/A,QMH,QMH/A,QMT2,QMT2/A,QMX2,QNE,QNE2,QNE2/A,QNE6,QNE9,QNE9/A,QNR2,QNR2/A,QNR6,QNR6/A,QN18,QPE2,QTC2,QTC2/A,QX,QX/A,QXB,QXB/A,QXB7,QXB7/A,QXE,QXE/A,QXEB,QXE2,QXE4,QXE4/A,QXE6,QXE6/A,QXE8,QXE8/A,QXQ4,QXQ4/A,QXU,QXU/A,QX2,SDE,SE,SE/A,SH,SH/A,SHB1,SHB3,SHB3/A,SHE,SHEZ,SHQ4,SHQ4/A,SJ,SJ/A,SJG,SJG/A,SKE,SKE/A,SKZ,SKZ/A,SME0,SME0/A,SME2,SMX2,SMX2/A,STJ,STJ/A,STP,STP/A,STQ,STQ/A,STR,STR/A,SX,SX/A,SBX,SBX/A,SBX7,SBX7/A,SXE,SXE/A,SXEB,SXEB/A,SXE2,SXE4,SXE4/A,SXE8,SXE8/A,SXP,SXQ4,SXQ4/A,SXU,SXU/A,VA,VAA,VAAE,VAD2,VAD2/A,VAH1,VAH2,VAW1,VA2,VA2/A,VDE,VDE2,VDE2/A,VD16,VE,VEB6,VH,VHE,VH12,VH12/A,VH22,VH22/A,VMX,VNG,VNG1,VNG2,VNSH7,VWA,VWA2,VWC2,VWC2/A,VWE2,VWE2/A,VWS2,VWS2/A,VW12,VW12/A,VX,VX/A,VXA,VXB,VXB/A,VXB2,VXB7,VXB7/A,VXE,VXE/A,VXEB,VXEB/A,VXE2,VXE2/A,VXE4,VXE6,VXE7,VXE7/A,VXE8,VXE8/A,VXG,VXK,VXQ4,VXQ4/A,VXU,VXU/A,VXU1,VXU1/A,VX16,VX16/A,VX8,VX8/A,YJ
10	90201-415-000	NUT, CAP, 6MM	2	(1) 2	-	-----	2205632 BJ,ED7,ED8,ED9,EN,ES,ES1,ET,ETS,ETX,HA,HH,HX,LH,LHE,LJ,LKE,LX,LXE,LXZ,L1,PX,P1,QA,QAE,QAP,QAPE,QE,QH,QHE,QNE,QX,QXB,QXE,QXEB,Q1,SE,SH,SHE,SHEZ,SJ,STJ,STP,STQ,SX,SBX,SXE,SXEB,SXP,S1,VA,VAA,VAAE,VAH1,VAH2,VE,VH,VHE,VNG,VNG1,VNG2,VWA,VX,VXA,VXB,VXE,VXEB,V1,YJ
			2	-	-	-----	2205608 HAQ,QAQ,QNE9
11	90203-PB2-000	NUT, AIR CLEANER COVER (DACRO COATING)	1	(1)	-	-----	2143835 BJ,ED7,EN,ES,ES1,ET,ETS,ETX,HA,HH,HX,LH,LHE,LJ,LKE,LX,LXE,LXZ,L1,PX,P1,QA,QAE,QAP,QAPE,QE,QH,QHE,QNE,QX,QXB,QXE,QXEB,Q1,SE,SH,SHE,SHEZ,SJ,STJ,STP,STQ,SX,SBX,SXE,SXEB,SXP,S1,VA,VAA,VAAE,VAH1,VAH2,VE,VH,VHE,VNG,VNG1,VNG2,VX,VXA,VXB,VXE,VXEB,V1,YJ
	90203-ZA0-800	NUT, WING, 6MM(BLACK)	1	(1)	-	-----	2143836 2313587 BJ,ED7,EN,ES,ES1,ET,ETS,ETX,HA,HH,HX,LH,LHE,LJ,LKE,LX,LXE,LXZ,L1,PX,P1,QA,QAE,QAP,QAPE,QE,QH,QHE,QNE,QX,QXB,QXE,QXEB,Q1,SE,SH,SHE,SHEZ,SJ,STJ,STP,STQ,SX,SBX,SXE,SXEB,SXP,S1,VA,VAA,VAAE,VAH1,VAH2,VE,VH,VHE,VNG,VNG1,VNG2,VX,VXA,VXB,VXE,VXEB,V1,YJ
			1	-	-	-----	HA2,HA2/A,HX2,HX26,HX26/A,LX2,LX2/A,LX26,LX26/A,QAB2,QAB2/A,QAC2,QAC2/A,QAE2,QAE2/A,QAE6,QAE6/A,QAG,QAG/A,QA2,QA2/A,QAP2,QAP2/A,QA2,QA2/A,QA26,QA26/A,QH2,QNE2,QNE2/A,QPE2,QXE2,QXE6,QXE6/A,QX2,VA2,VA2/A,VWE2,VWE2/A,VXE2,VXE2/A
			1	-	-	-----	2313587 ED8,ED9,VDE,VWA,VXG,VXU,VXU1
			1	-	-	-----	2319648 HAQ,QAQ,QNE9



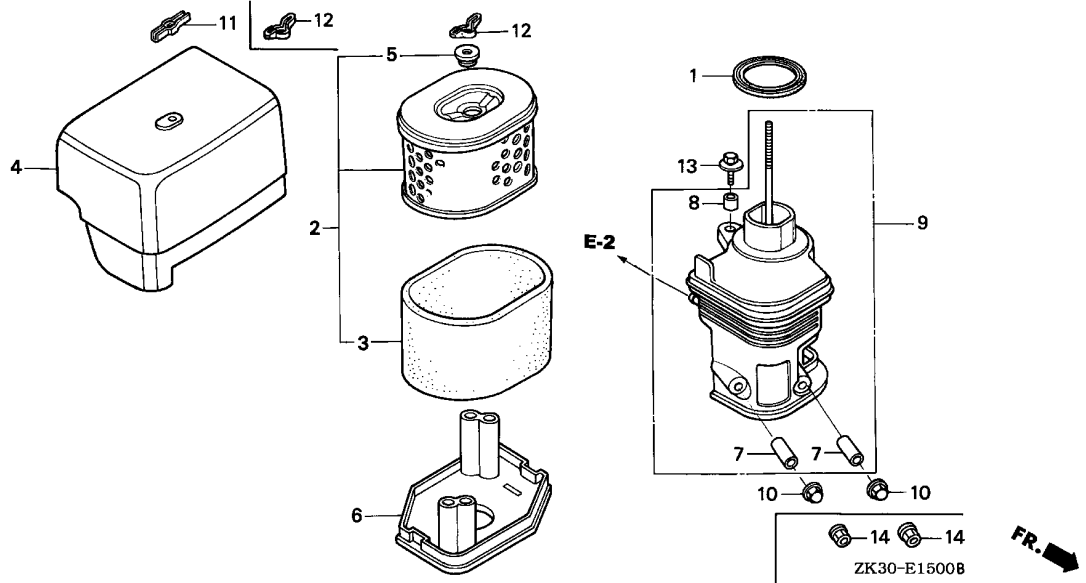

Ref. No.	Part No.	Description	Reqd. QTY			Serial No.	Parts catalogue code
			GX	340K1			
12	90325-044-000	NUT, TOOL BOX SETTING .....	1	(1)	-	2313587	BJ,ED7,ED8,ED9,EN,ES,ES1,ET,ETS,ETX,HA,HH,HX,LH,LHE,LJ,LKE,LX,LXE,LXZ,L1,PX,P1,QA,QAE,QAP,QAPE,QE,QH,QHE,QNE,QX,QXB,QXE,QXEB,Q1,SE,SH,SHE,SHEZ,SJ,STJ,STP,STQ,SX,SXB,SXE,SXEB,SXP,S1,VA,VAA,VAAE,VAH1,VAH2,VDE,VE,VH,VHE,VNG,VNG1,VNG2,VWA,VX,VXA,VXB,VXE,VXEB,VXG,VXU,VXU1,V1,YJ

Ref. No.	Part No.	Description	Reqd. QTY			Serial No.	Parts catalogue code
			(1)	(2)	(3)		
12)	90325-044-000	NUT, TOOL BOX SETTING .....	1	-	-	-----	HA2,HA2/A,HX2,HX26,HX26/A,LX2,LX2/A,LX26,LX26/A,QAB2,QAB2/A,QAC2,QAC2/A,QAE2,QAE2/A,QAE6,QAE6/A,QAG,QAG/A,QA2,QA2/A,QAP2,QAP2/A,QA2,QA2/A,QA26,QA26/A,QH2,QNE2,QNE2/A,QPE2,QXE2,QXE6,QXE6/A,QX2,VA2,VA2/A,VWE2,VWE2/A,VXE2,VXE2/A
			1	-	-	2319648	HAQ,QAQ,QNE9
			2	-	-	-----	ES2
			2	(2)	-	-----	EDK,EDN5,EDN5/A,ED8/A,ED9/A,ES1/A,ES2,LH/A,LHB1,LHB3,LHB3/A,LHB5,LHE/A,LHQ4,LHQ4/A,LJ/A,LJG,LJG/A,LJS1,LKE/A,LSX,LWD,LX/A,LXE/A,LXE2,LXE2/A,LXE4,LXE4/A,LXE6,LXE8,LXE8/A,LXQ4,LXQ4/A,LXU,LXU/A,L1/A,PKT2,PKT2/A,PKT4,PKT4/A,PKX2,PKX4,PKX4/A,PX/A,PXE8,PXE8/A,P1/A,QE/A,QH/A,QHB3,QHB3/A,QHB5,QHE/A,QHP1,QHP1/A,QHQ4,QHQ4/A,QKA4,QKA4/A,QL2,QMEO,QMEO/A,QME8,QME8/A,QMH,QMH/A,QMT2,QMT2/A,QMX2,QNE6,QNE9/A,QNR2,QNR2/A,QNR6,QNR6/A,QN18,QTC2,QTC2/A,QX/A,QXB/A,QXB7,QXB7/A,QXE/A,QXE4,QXE4/A,QXE8,QXE8/A,QXQ4,QXQ4/A,QXU,QXU/A,Q1/A,SDE,SE/A,SH/A,SHB1,SHB3,SHB3/A,SHQ4,SHQ4/A,SJ/A,SJG,SJG/A,SKE,SKE/A,SKZ,SKZ/A,SMEO,SMEO/A,SMX2,SMX2/A,STJ/A,STP/A,STQ/A,STR,STR/A,SX/A,SXB/A,SXB7,SXB7/A,SXE/A,SXEB/A,SXE4,SXE4/A,SXE8,SXE8/A,SXQ4,SXQ4/A,SXU,SXU/A,S1/A,VAD2,VAD2/A,VAW1,VDE2,VDE2/A,VD16,VEB6,VH12,VH12/A,VH22,VH22/A,VMX,VSH7,VWC2,VWC2/A,VWS2,VWS2/A,VW12,VW12/A,VX/A,VXB/A,VXB2,VXB7,VXB7/A,VXE/A,VXEB/A,VXE4,VXE6,VXE7,VXE7/A,VXE8,VXE8/A,VXK,VXQ4,VXQ4/A,VXU/A,VXU1/A,VX16,VX16/A,VX8,VX8/A
			2	(2)	-	2313588	BJ,ED7,ED8,ED9,EN,ES,ES1,ET,ETS,ETX,HA,HH,HX,LH,LHE,LJ,LKE,LX,LXE,LXZ,L1,PX,P1,QA,QAE,QAP,QAPE,QE,QH,QHE,QNE,QX,QXB,QXE,QXEB,Q1,SE,SH,SHE,SHEZ,SJ,STJ,STP,STQ,SX,SXB,SXE,SXEB,SXP,S1,VA,VAA,VAE,VAH1,VAH2,VDE,VE,VH,VHE,VNG,VNG1,VNG2,VVA,VX,VXA,VXB,VXE,VXEB,VXG,VXU,VXU1,V1,YJ
			2	-	-	2319649	HAQ,QAQ,QNE9
			-	-	2	-----	
13	93494-06020-08	BOLT-WASHER, 6X20 .....	1	(1)	-	-----	BJ,ED7,ES,ES1,ES1/A,HH,HX,LH,LH/A,LHE,LHE/A,LJ,LJ/A,LXE,LXE/A,LXE8,LXE8/A,LXU,LXU/A,LXZ,L1,L1/A,PX,PX/A,QA,QAE,QAP,QE,QE/A,QH,QH/A,QHE,QHE/A,QNE,QNE9,QNE9/A,QX,QX/A,QXB,QXB/A,QXE,QXE/A,QXEB,QXE8,QXE8/A,QXU,QXU/A,Q1,Q1/A,SE,SE/A,SH,SH/A,SHE,SHEZ,SJ,SJ/A,STP,STP/A,STQ,STQ/A,SX,SX/A,SXB,SXB/A,SXE,SXE/A,SXEB,SXEB/A,SXE8,SXE8/A,SXP,SXU,SXU/A,S1,S1/A,VA,VAA,VAE,VAH1,VAH2,VE,VH,VHE,VNG,VNG1,VNG2,VX,VX/A,VXA,VXB,VXB/A,VXEB,VXEB/A,V1,YJ
	93404-06020-08	.....	1	(1)	-	-----	EN,ET,ETS,ETX,HA,HAQ,HX2,LHB1,LSX,LXE6,P1,P1/A,QAPE,QAQ,QH2,QMX2,QNE6,QN18,QPE2,QXE2,QX2,SDE,SME2,SXE2,VAW1,VDE,VD16,VEB6,VMX,VWA,VWA2,VXB2,VXE4,VXE6,VXG
	90009-ZE2-003	BOLT-WASHER, 6X22 .....	1	-	-	-----	EDK,EDN5,EDN5/A,ED8,ED8/A,ED9,ED9/A,ES2,HA2,HA2/A,HX26/A,LHB3,LHB3/A,LHB5,LHQ4,LHQ4/A,LJG,LJG/A,LJS1,LKE,LKE/A,LWD,LX,LX/A,LXE2,LXE2/A,LXE4,LXE4/A,LXQ4,LXQ4/A,LX2,LX2/A,LX26,LX26/A,PKT2,PKT2/A,PKT4,PKT4/A,PKX2,PKX4,PKX4/A,PXE8,PXE8/A,QAB2,QAB2/A,QAC2,QAC2/A,QAE2,QAE2/A,QAE6,QAE6/A,QAG,QAG/A,QA2,QA2/A,QAP2,QAP2/A,QA2,QA2/A,QA26,QA26/A,QHB3,QHB3/A,QHB5,QHP1,QHP1/A,QHQ4,QHQ4/A,QKA4,QKA4/A,QL2,QMEO,QMEO/A,QME8,QME8/A,QMH,QMH/A,QMT2,QMT2/A,QNE2,QNE2/A,QNE9,QNE9/A,QNR2,QNR2/A,QNR6,QNR6/A,QTC2,QTC2/A,QXB7,QXB7/A,QXE4,QXE4/A,QXE6,QXE6/A,QXQ4,QXQ4/A,SHB1,SHB3,SHB3/A,SHQ4,SHQ4/A,SJG,SJG/A,SKE,SKE/A,SKZ,SKZ/A,SMEO,SMEO/A,SMX2,SMX2/A,STJ,STJ/A,STR,STR/A,SXB7,SXB7/A,SXE4,SXE4/A,SXQ4,SXQ4/A,VAD2,VAD2/A,VA2,VA2/A,VDE2,VDE2/A,VH12,VH12/A,VH22,VH22/A,VSH7,VWC2,VWC2/A,VWE2,VWE2/A,VWS2,VWS2/A,VW12,VW12/A,VXB7,VXB7/A,VXE,VXE/A,VXE2,VXE2/A,VXE7,VXE7/A,VXE8,VXE8/A,VXK,VXQ4,VXQ4/A,VXU,VXU/A,VXU1,VXU1/A,VX16,VX16/A,VX8,VX8/A
			-	-	1	-----	



E-15

AIR CLEANER(1)

N14

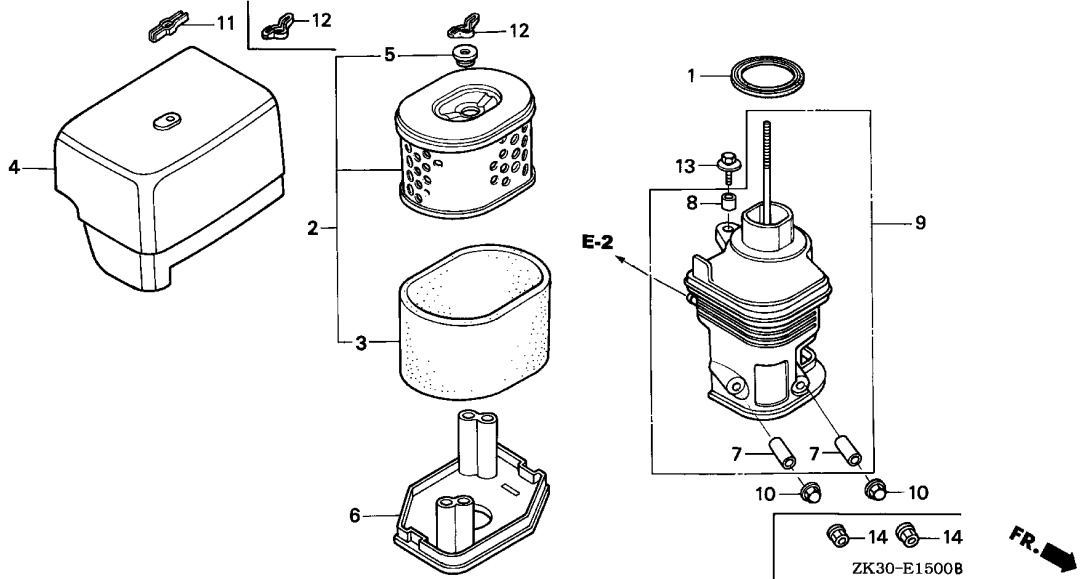

Ref. No.	Part No.	Description	Reqd. QTY			Serial No.	Parts catalogue code		
			GX	(1)	(2)			(3)	
14	94050-06000	NUT, FLANGE, 6MM .....	2	2	-	EDK,EDN5,EDN5/A,ED8/A,ED9/A,ENT2,ES1/A,ES2,HA2,HA2/A,HX2,HX26 HX26/A,LH/A,LHB1,LHB3,LHB3/A,LHB5,LHE/A,LHQ4,LHQ4/A,LJ/A,LJG LJG/A,LJS1,LKE/A,LSX,LWD,LX/A,LXE/A,LXE2,LXE2/A,LXE4,LXE4/A,LXE6 LXE8,LXE8/A,LXQ4,LXQ4/A,LXU,LXU/A,LX2,LX2/A,LX26,LX26/A,L1/A,PKT2 PKT2/A,PKT4,PKT4/A,PKX2,PKX4,PKX4/A,PX/A,PXE8,PXE8/A,P1/A,QAB2 QAB2/A,QAC2,QAC2/A,QAE2,QAE2/A,QAE6,QAE6/A,QAG,QAG/A,QA2,QA2/A QAP2,QAP2/A,QA2,QA2/A,QA26,QA26/A,QE/A,QH/A,QHB3,QHB3/A,QHB5 QHE/A,QHP1,QHP1/A,QHQ4,QHQ4/A,QH2,QKA4,QKA4/A,QL2,QME0,QME0/A QME8,QME8/A,QMH,QMH/A,QMT2,QMT2/A,QMX2,QNE2,QNE2/A,QNE6,QNE9/A QNR2,QNR2/A,QNR6,QNR6/A,QN18,QPE2,QTC2,QTC2/A,QX/A,QXB/A,QXB7 QXB7/A,QXE/A,QXE2,QXE4,QXE4/A,QXE6,QXE6/A,QXE8,QXE8/A,QXQ4,QXQ4/A QXU,QXU/A,QX2,Q1/A,SDE,SE/A,SH/A,SHB1,SHB3,SHB3/A,SHQ4,SHQ4/A SJ/A,SJG,SJG/A,SKE,SKE/A,SKZ,SKZ/A,SME0,SME0/A,SME2,SMX2,SMX2/A STJ/A,STP/A,STQ/A,STR,STR/A,SX/A,SXB/A,SXB7,SXB7/A,SXE/A,SXEB/A SX2,SXE4,SXE4/A,SXE8,SXE8/A,SXQ4,SXQ4/A,SXU,SXU/A,S1/A,VAD2 VAD2/A,VAW1,VA2,VA2/A,VDE,VDE2,VDE2/A,VD16,VEB6,VH12,VH12/A,VH22 VH22/A,VMX,VSH7,VWA2,VWC2,VWC2/A,VWE2,VWE2/A,VWS2,VWS2/A,VW12 VW12/A,VX/A,VXB/A,VXB2,VXB7,VXB7/A,VXE/A,VXEB/A,VXE2,VXE2/A,VXE4 VXE6,VXE7,VXE7/A,VXE8,VXE8/A,VXG,VXK,VXQ4,VXQ4/A,VXU,VXU/A,VXU1 VXU1/A,VX16,VX16/A,VX8,VX8/A,ZK1,ZK1/A			
			2	2	-	2205633 ----- BJ,ED7,ED8,ED9,EN,ES,ES1,ET,ETS,ETX,HA,HH,HX,LH,LHE,LJ,LKE,LX,LXE LXZ,L1,PX,P1,QA,QAE,QAP,QAPE,QE,QH,QHE,QNE,QX,QXB,QXE,QXEB,Q1,SE SH,SHE,SHEZ,SJ,STJ,STP,STQ,SX,SXB,SXE,SXEB,SXP,S1,VA,VAA,VAAE VAH1,VAH2,VE,VH,VHE,VNG,VNG1,VNG2,VWA,VX,VXA,VXB,VXE,VXEB,V1,YJ			
			2	-	-	2205609 ----- HAQ,QAQ,QNE9			
			-	-	2				



# E-15-1

# AIR CLEANER(2)

**N15**

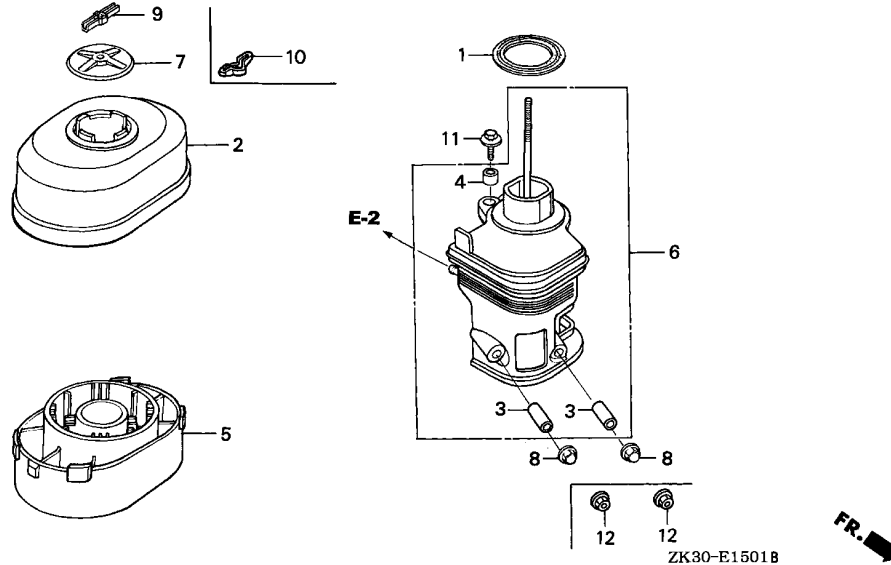

Ref. No.	L.O.N.	(Relative ref. Number) Description	F.R.T.
1	3121E1	PACKING, ELBOW .....	0.1
5	3121E5	PAN, AIR CLEANER OIL .....	0.1
6	3121B4	ELBOW, AIR CLEANER .....	0.1

Ref. No.	Part No.	Description	Reqd. QTY			Serial No.	Parts catalogue code
			GX 340K1 (1)	(2)	(3)		
1	16271-ZE2-010	PACKING, ELBOW .....	1	-	-	LHW,LJS,LJS/A,LT,LT/A,QP,QP/A,QT,QT/A,SWX,SWX/A	
2	17230-ZE3-811	COVER COMP., AIR CLEANER (OIL BATH)	1	-	-	LHW,LJS,LJS/A,LT,LT/A,QP,QP/A,QT,QT/A,SWX,SWX/A	
3	17238-ZE2-310	COLLAR, AIR CLEANER .....	2	-	-	LHW,LJS,LJS/A,LT,LT/A,QP,QP/A,QT,QT/A,SWX,SWX/A	
4	17239-ZE1-000	COLLAR B, AIR CLEANER .....	1	-	-	LHW,LJS,LJS/A,LT,LT/A,QP,QP/A,QT,QT/A,SWX,SWX/A	
5	17402-ZE3-810	PAN, CLEANER OIL (OIL BATH)	1	-	-	LHW,LJS,LJS/A,LT,LT/A,QP,QP/A,QT,QT/A,SWX,SWX/A	
6	17410-ZE3-010	ELBOW COMP., AIR CLEANER ....	1	-	-	LHW,LJS,LJS/A,LT,LT/A,QP,QP/A,QT,QT/A,SWX,SWX/A	
7	17420-ZE3-810	CAP COMP., AIR CLEANER .....	1	-	-	LHW,LJS,LJS/A,LT,LT/A,QP,QP/A,QT,QT/A,SWX,SWX/A	
8	90201-415-000	NUT, CAP, 6MM .....	2	(2)	-	2205632 L1,P1,QP,QT,Q1,SWX,S1,V1	
9	90203-PB2-000	NUT, AIR CLEANER COVER (DACRO COATING)	1	(1)	-	2143835 L1,P1,QP,QT,Q1,SWX,S1,V1	
	90203-ZA0-800	NUT, WING, 6MM(BLACK) .....	1	(1)	-	2143836 2313587 L1,QP,QT,SWX,S1	
			-	(1)	-	P1/A,Q1/A	
			-	(1)	-	2143836 P1,Q1,V1	
10	90325-044-000	NUT, TOOL BOX SETTING .....	1	(1)	-	LHW,LJS,LJS/A,LT,LT/A,L1/A,QP/A,QT/A,SWX/A,S1/A	
			1	(1)	-	2313588 L1,QP,QT,SWX,S1	
11	93494-06020-08	BOLT-WASHER, 6X20 .....	1	(1)	-	L1,L1/A,QP,QP/A,QT,QT/A,Q1,Q1/A,SWX,SWX/A,S1,S1/A,V1	
	93404-06020-08	.....	1	(1)	-	LHW,P1,P1/A	
	90009-ZE2-003	BOLT-WASHER, 6X22 .....	1	-	-	LJS,LJS/A,LT,LT/A	
12	94050-06000	NUT, FLANGE, 6MM .....	2	(2)	-	LHW,LJS,LJS/A,LT,LT/A,L1/A,P1/A,QP/A,QT/A,Q1/A,SWX/A,S1/A	
			2	(2)	-	2205633 L1,P1,QP,QT,Q1,SWX,S1,V1	



# E-15-2

# AIR CLEANER(3)

**N16**

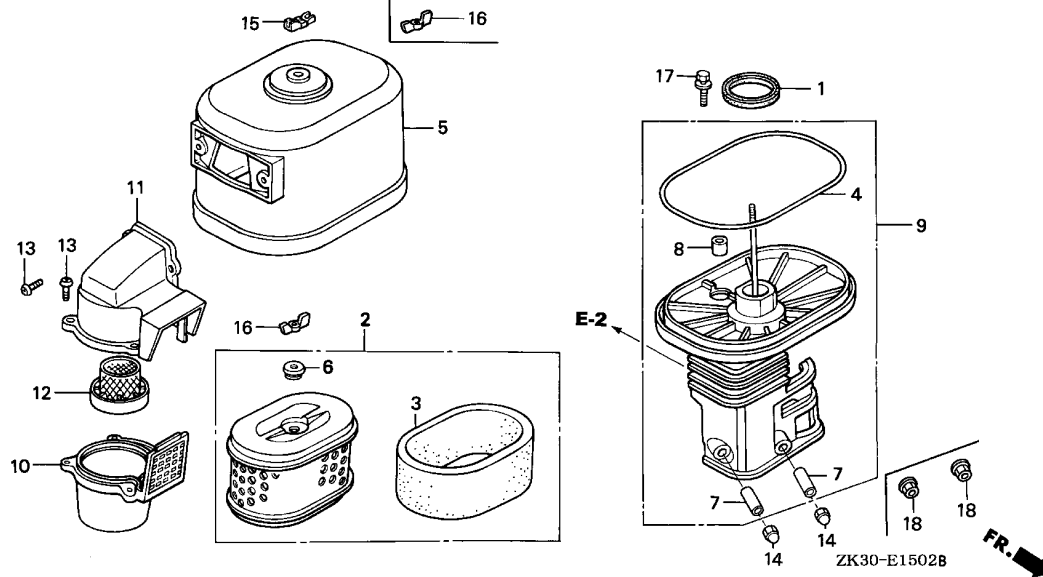

Ref. No.	L.O.N.	(Relative ref. Number) Description	F.R.T.
1	3121E1	PACKING, ELBOW .....	0.1
2	3121B8	ELEMENT, AIR CLEANER .....	0.1
		.INCLUDES: Air cleaner- inspection	
3	3121C1	FILTER, OUTER .....	0.1
4	3121E0	PACKING, AIR CLEANER COVER ...	0.1
9	3121B4	ELBOW, AIR CLEANER .....	0.1
10	3121A6	CASE, PRE AIR CLEANER .....	0.1
11	3121A4	CAP, PRE AIR CLEANER .....	0.1
12	3121C8	GUIDE, PRE AIR CLEANER .....	0.1

Ref. No.	Part No.	Description	Reqd. QTY			Serial No.	Parts catalogue code
			GX	(1)	(2)		
1	16271-ZE2-010	PACKING, ELBOW .....	1	-	-	LHC,QDW9,QDW9/A,QHC,QWH2,QWH2/A,QXC,QXC/A,QXC4,QXC4/A,QXC6,QXC6/A,QXC9,QXC9/A,SHT	
2	17210-ZE3-010	ELEMENT, AIR CLEANER .....	1	(1)	-	LHC,QDW9,QDW9/A,QHC,QWH2,QWH2/A,QXC,QXC/A,QXC4,QXC4/A,QXC6,QXC6/A,QXC9,QXC9/A,SHT	
3	17218-ZE3-000	FILTER, OUTER .....	1	(1)	-	LHC,QDW9,QDW9/A,QHC,QWH2,QWH2/A,QXC,QXC/A,QXC4,QXC4/A,QXC6,QXC6/A,QXC9,QXC9/A,SHT	
4	17219-ZE3-840	PACKING, AIR CLEANER COVER ..	1	(1)	-	LHC,QDW9,QDW9/A,QHC,QWH2,QWH2/A,QXC,QXC/A,QXC4,QXC4/A,QXC6,QXC6/A,QXC9,QXC9/A,SHT	
5	17230-ZE3-841	COVER COMP., AIR CLEANER (CYCLONE)	1	(1)	-	LHC,QDW9,QDW9/A,QHC,QWH2,QWH2/A,QXC,QXC/A,QXC4,QXC4/A,QXC6,QXC6/A,QXC9,QXC9/A,SHT	
6	17232-891-000	GROMMET, AIR CLEANER .....	1	(1)	-	LHC,QDW9,QDW9/A,QHC,QWH2,QWH2/A,QXC,QXC/A,QXC4,QXC4/A,QXC6,QXC6/A,QXC9,QXC9/A,SHT	
7	17238-ZE2-310	COLLAR, AIR CLEANER .....	2	(1)	-	LHC,QDW9,QDW9/A,QHC,QWH2,QWH2/A,QXC,QXC/A,QXC4,QXC4/A,QXC6,QXC6/A,QXC9,QXC9/A,SHT	
8	17239-ZE3-840	COLLAR B, AIR CLEANER .....	1	(2)	-	LHC,QDW9,QDW9/A,QHC,QWH2,QWH2/A,QXC,QXC/A,QXC4,QXC4/A,QXC6,QXC6/A,QXC9,QXC9/A,SHT	
9	17410-ZE3-840	ELBOW COMP., AIR CLEANER ....	1	(1)	-	LHC,QDW9,QDW9/A,QHC,QWH2,QWH2/A,QXC,QXC/A,QXC4,QXC4/A,QXC6,QXC6/A,QXC9,QXC9/A,SHT	

**2**

Ref. No.	Part No.	Description	Reqd. QTY			Serial No.	Parts catalogue code
			(1)	(2)	(3)		
10	17470-ZE3-841	CASE COMP., PRE AIR CLEANER	1	(1)	-	-----	LHC,L1,P1,QDW9,QHC,QWH2,QXC,QXC4,QXC6,QXC9,Q1,SHT,S1,V1
	17470-ZE3-842	.....	1	(1)	-	-----	L1/A,P1/A,QDW9/A,QWH2/A,QXC/A,QXC4/A,QXC6/A,QXC9/A,Q1/A,S1/A
11	17475-ZE3-841	CAP, PRE AIR CLEANER	1	-	-	-----	LHC,QDW9,QDW9/A,QHC,QWH2,QWH2/A,QXC,QXC/A,QXC4,QXC4/A,QXC6,QXC6/A,QXC9,QXC9/A,SHT
12	17476-ZE3-841	GUIDE, PRE AIR CLEANER	1	(1)	-	-----	LHC,QDW9,QDW9/A,QHC,QWH2,QWH2/A,QXC,QXC/A,QXC4,QXC4/A,QXC6,QXC6/A,QXC9,QXC9/A,SHT
13	90142-MB0-000	SCREW, PAN, 5X16.5	5	(1)	-	-----	LHC,QDW9,QDW9/A,QHC,QWH2,QWH2/A,QXC,QXC/A,QXC4,QXC4/A,QXC6,QXC6/A,QXC9,QXC9/A,SHT
14	90201-415-000	NUT, CAP, 6MM	2	(5)	-	-----	2205632 LHC,L1,P1,QHC,QXC,Q1,S1,V1
15	90203-PB2-000	NUT, AIR CLEANER COVER (DACRO COATING)	1	(1)	-	-----	2143835 LHC,L1,P1,QHC,Q1,S1,V1
			1	-	-	-----	2147715 QXC
	90203-ZA0-800	NUT, WING, 6MM(BLACK)	1	-	-	-----	2313587 SHT
			1	-	-	-----	2143836 2313587 LHC,QHC
			1	-	-	-----	2147716 2313587 QXC
			-	(1)	-	-----	L1/A,P1/A,Q1/A,S1/A
			-	(1)	-	-----	2143836 L1,P1,Q1,S1,V1
16	90325-044-000	NUT, TOOL BOX SETTING	1	-	-	-----	2313587 LHC,QHC,QXC,SHT
			-	(1)	-	-----	
			2	-	-	-----	QDW9,QDW9/A,QWH2,QWH2/A,QXC/A,QXC4,QXC4/A,QXC6,QXC6/A,QXC9,QXC9/A
			2	-	-	-----	2313588 LHC,QHC,QXC,SHT
17	93494-06020-08	BOLT-WASHER, 6X20	1	1	-	-----	LHC,L1,L1/A,QHC,QXC,QXC/A,Q1,Q1/A,S1,S1/A,V1
	93404-06020-08	.....	1	1	-	-----	P1,P1/A,SHT
	90009-ZE2-003	BOLT-WASHER, 6X22	1	-	-	-----	QDW9,QDW9/A,QWH2,QWH2/A,QXC4,QXC4/A,QXC6,QXC6/A,QXC9,QXC9/A
18	94050-06000	NUT, FLANGE, 6MM	2	2	-	-----	L1/A,P1/A,QDW9,QDW9/A,QWH2,QWH2/A,QXC/A,QXC4,QXC4/A,QXC6,QXC6/A,QXC9,QXC9/A,Q1/A,SHT,S1/A
			2	2	-	-----	2205633 LHC,L1,P1,QHC,QXC,Q1,S1,V1



E-15-3

AIR CLEANER(4)

2-B 2

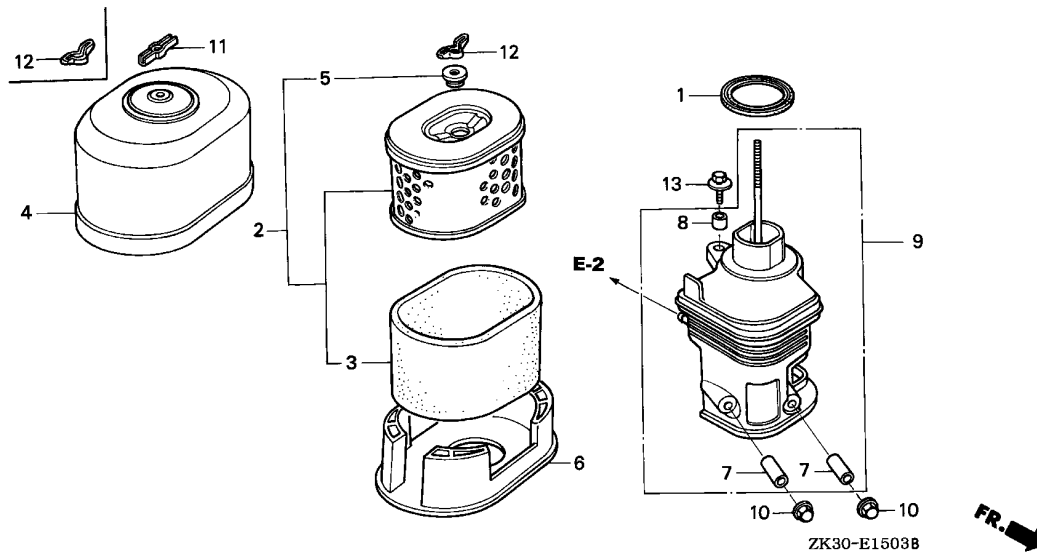

Ref. No.	L.O.N.	(Relative ref. Number) Description	F.R.T.
1	3121E1	PACKING, ELBOW .....	0.1
2	3121B8	ELEMENT, AIR CLEANER .....	0.1
.INCLUDES: Air cleaner- inspection			
3	3121C1	FILTER, OUTER .....	0.1
6	3121D6	NOSE, SILENCER .....	0.1
9	3121B4	ELBOW, AIR CLEANER .....	0.1

Ref. No.	Part No.	Description	Reqd. QTY			Serial No.	Parts catalogue code
			GX	340K1	(3)		
1	16271-ZE2-010	PACKING, ELBOW .....	1	-	-	----- PXA2	
2	17210-ZE3-010	ELEMENT, AIR CLEANER .....	1	(1)	-	----- L1,L1/A,PXA2,P1,P1/A,Q1,Q1/A,S1,S1/A	
3	17218-ZE3-000	FILTER, OUTER .....	1	-	-	----- PXA2	
4	17230-ZE3-000	COVER, AIR CLEANER (STD.) ...	1	-	-	----- PXA2	
5	17232-891-000	GROMMET, AIR CLEANER .....	1	-	-	----- PXA2	
6	17235-ZE3-000	NOSE, SILENCER .....	1	-	-	----- PXA2	
7	17238-ZE2-310	COLLAR, AIR CLEANER .....	2	-	-	----- PXA2	
8	17239-ZE1-000	COLLAR B, AIR CLEANER .....	1	-	-	----- PXA2	
9	17410-ZE3-010	ELBOW COMP., AIR CLEANER ....	1	-	-	----- PXA2	
10	90201-415-000	NUT, CAP, 6MM .....	-	(2)	-	----- 2205632 L1,P1,Q1,S1,V1	
	94050-06000	NUT, FLANGE, 6MM .....	-	(2)	-	----- L1/A,PXA2,P1/A,Q1/A,S1/A	
			-	(2)	-	----- 2205633 L1,P1,Q1,S1,V1	
11	90203-PB2-000	NUT, AIR CLEANER COVER (DACRO COATING)	-	(1)	-	----- 2143835 L1,P1,Q1,S1,V1	
	90203-ZA0-800	NUT, WING, 6MM(BLACK) .....	-	(1)	-	----- 2143836 L1,P1,Q1,S1,V1	
12	90325-044-000	NUT, TOOL BOX SETTING .....	-	(1)	-	----- 2313587 L1,P1,Q1,S1,V1	
			2	(2)	-	----- L1/A,PXA2,P1/A,Q1/A,S1/A	
			-	(2)	-	----- 2313588 L1,P1,Q1,S1,V1	
13	90009-ZE2-003	BOLT-WASHER, 6X22 .....	(1)	-	-	----- PXA2	
	93494-06020-08	BOLT-WASHER, 6X20 .....	-	(1)	-	-----	

2

E-15-4

AIR CLEANER(5)

2-B 3

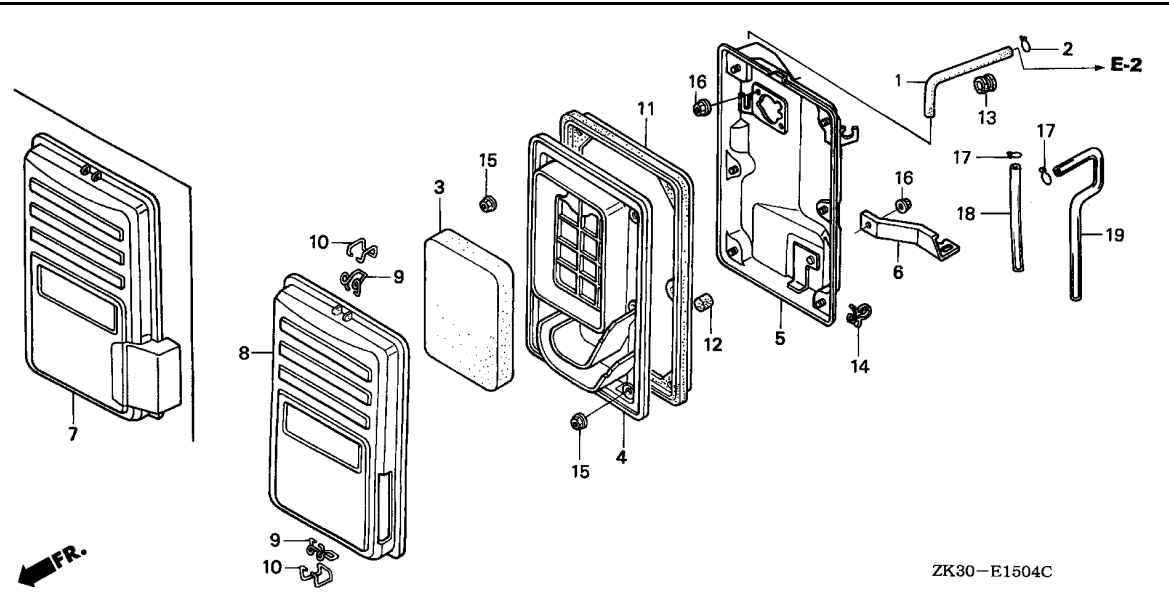

Ref. No.	L.O.N.	(Relative ref. Number) Description	F.R.T.
3	3121B8	ELEMENT, AIR CLEANER ..... .INCLUDES: Air cleaner- inspection	0.1
4	3121F0	SEPARATOR, AIR CLEANER .....	0.1
5	3121A5	CASE, AIR CLEANER .....	0.2
11	3121E8	SEAL, AIR CLEANER CASE .....	0.1

Ref. No.	Part No.	Description	Reqd. QTY			Serial No.	Parts catalogue code
			GX	340K1			
			(1)	(2)	(3)		
1	15721-ZB4-000	TUBE, BREATHER .....	1	-	-	-----	EDE2,EDE2/A,EDN,EDN2,EDN2/A,EDS,EDS1,EDS1/A,EDS2,EDS2/A,EDS3,EDS4 EDS6,EDS6/A,EDT,EDT/A,EDT1,EDT1/A,EDT2,EDT3,EDT6,EDT6/A,ED6,ED6/A EMT,EMT/A,ENT,ENT/A,ENT2,EN6,EN6/A,ES3,ES3/A,ES4,ES4/A,VC2,VC2/A VMQ,VMT,VMT/A,VS2,VS3,VS4,VS5,VS6,VS7,VTE2,VVC,VVE
	15721-ZB7-000	.....	1	-	-	-----	EDS5
2	15772-292-010	CLIP, BREATHER TUBE .....	1	-	-	-----	EDS5
3	17211-899-000	ELEMENT, AIR CLEANER .....	1	-	-	-----	EDE2,EDE2/A,EDN,EDN2,EDN2/A,EDS,EDS1,EDS1/A,EDS2,EDS2/A,EDS3,EDS4 EDS5,EDS6,EDS6/A,EDT,EDT/A,EDT1,EDT1/A,EDT2,EDT3,EDT6,EDT6/A,ED6 ED6/A,EMT,EMT/A,ENT,ENT/A,ENT2,EN6,EN6/A,ES3,ES3/A,ES4,ES4/A,VC2 VC2/A,VMQ,VMT,VMT/A,VS2,VS3,VS4,VS5,VS6,VS7,VTE2,VVC,VVE
4	17212-ZB4-003	SEPARATOR, AIR CLEANER .....	1	-	-	-----	EDE2,EDE2/A,EDN,EDN2,EDN2/A,EDS,EDS1,EDS1/A,EDS2,EDS2/A,EDS3,EDS4 EDS5,EDS6,EDS6/A,EDT,EDT/A,EDT1,EDT1/A,EDT2,EDT3,EDT6,EDT6/A,ED6 ED6/A,EMT,EMT/A,ENT,ENT/A,ENT2,EN6,EN6/A,ES3,ES3/A,ES4,ES4/A,VC2 VC2/A,VMQ,VMT,VMT/A,VS2,VS3,VS4,VS5,VS6,VS7,VTE2,VVC,VVE
5	17220-ZB4-003	CASE COMP., AIR CLEANER .....	1	-	-	-----	EDE2,EDE2/A,EDN,EDN2,EDN2/A,EDS,EDS1,EDS1/A,EDS2,EDS2/A,EDS3,EDS4 EDS6,EDS6/A,EDT,EDT/A,EDT1,EDT1/A,EDT2,EDT3,EDT6,EDT6/A,ED6,ED6/A EMT,EMT/A,ENT,ENT/A,ENT2,EN6,EN6/A,ES3,ES3/A,ES4,ES4/A,VC2,VC2/A VMQ,VMT,VMT/A,VS2,VS3,VS4,VS5,VS6,VS7,VTE2,VVC,VVE
	17220-ZB7-000	.....	1	-	-	-----	EDS5
6	17222-ZC2-000	STAY, AIR CLEANER .....	1	-	-	-----	EDE2,EDE2/A,EDN,EDN2,EDN2/A,EDS,EDS1,EDS1/A,EDS2,EDS2/A,EDS3,EDS4 EDS6,EDS6/A,EDT,EDT/A,EDT1,EDT1/A,EDT2,EDT3,EDT6,EDT6/A,ED6,ED6/A EMT,EMT/A,ENT,ENT/A,ENT2,EN6,EN6/A,ES3,ES3/A,ES4,ES4/A,VC2,VC2/A VMQ,VMT,VMT/A,VS2,VS3,VS4,VS5,VS6,VS7,VTE2,VVC,VVE
	17222-ZB8-000	.....	1	-	-	-----	EDS5
7	17231-ZB7-000	COVER COMP., AIR CLEANER .....	1	-	-	-----	EDS5

2

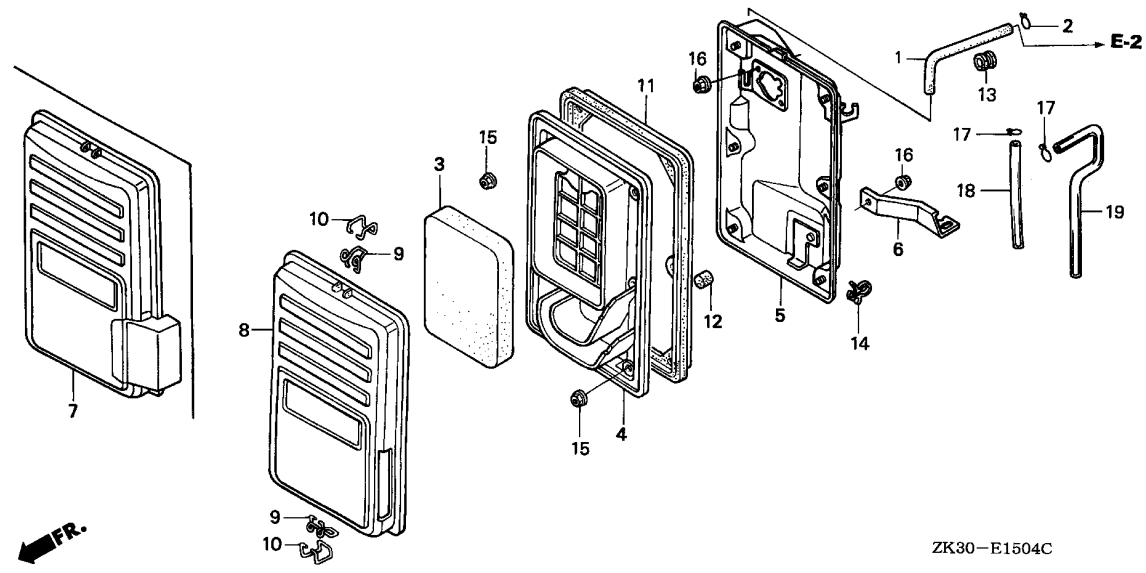

ZK30-E1504C

Ref. No.	Part No.	Description	Reqd. QTY			Serial No.	Parts catalogue code
			GX	(1)	(2)		
8	17231-899-000	COVER COMP., AIR CLEANER	1	-	-	-----	EDE2,EDE2/A,EDN,EDN2,EDN2/A,EDS,EDS1,EDS1/A,EDS2,EDS2/A,EDS3,EDS4,EDS6,EDS6/A,EDT,EDT/A,EDT1,EDT1/A,EDT2,EDT3,EDT6,EDT6/A,ED6,ED6/A,EMT,EMT/A,ENT,ENT/A,ENT2,EN6,EN6/A,ES3,ES3/A,ES4,ES4/A,VC2,VC2/A,VMQ,VMT,VMT/A,VS2,VS3,VS4,VS5,VS6,VS7,VTE2,VWC,VWE
9	17235-899-000	CLIP A, AIR CLEANER WIRE	2	-	-	-----	EDE2,EDE2/A,EDN,EDN2,EDN2/A,EDS,EDS1,EDS1/A,EDS2,EDS2/A,EDS3,EDS4,EDS5,EDS6,EDS6/A,EDT,EDT/A,EDT1,EDT1/A,EDT2,EDT3,EDT6,EDT6/A,ED6,ED6/A,EMT,EMT/A,ENT,ENT/A,ENT2,EN6,EN6/A,ES3,ES3/A,ES4,ES4/A,VC2,VC2/A,VMQ,VMT,VMT/A,VS2,VS3,VS4,VS5,VS6,VS7,VTE2,VWC,VWE
10	17236-899-000	CLIP B, AIR CLEANER WIRE	2	-	-	-----	EDE2,EDE2/A,EDN,EDN2,EDN2/A,EDS,EDS1,EDS1/A,EDS2,EDS2/A,EDS3,EDS4,EDS5,EDS6,EDS6/A,EDT,EDT/A,EDT1,EDT1/A,EDT2,EDT3,EDT6,EDT6/A,ED6,ED6/A,EMT,EMT/A,ENT,ENT/A,ENT2,EN6,EN6/A,ES3,ES3/A,ES4,ES4/A,VC2,VC2/A,VMQ,VMT,VMT/A,VS2,VS3,VS4,VS5,VS6,VS7,VTE2,VWC,VWE
11	17252-899-000	SEAL, AIR CLEANER	1	-	-	-----	EDE2,EDE2/A,EDN,EDN2,EDN2/A,EDS,EDS1,EDS1/A,EDS2,EDS2/A,EDS3,EDS4,EDS5,EDS6,EDS6/A,EDT,EDT/A,EDT1,EDT1/A,EDT2,EDT3,EDT6,EDT6/A,ED6,ED6/A,EMT,EMT/A,ENT,ENT/A,ENT2,EN6,EN6/A,ES3,ES3/A,ES4,ES4/A,VC2,VC2/A,VMQ,VMT,VMT/A,VS2,VS3,VS4,VS5,VS6,VS7,VTE2,VWC,VWE
12	17367-413-690	FILTER, DRAIN TUBE	1	-	-	-----	EDE2,EDE2/A,EDN,EDN2,EDN2/A,EDS,EDS1,EDS1/A,EDS2,EDS2/A,EDS3,EDS4,EDS5,EDS6,EDS6/A,EDT,EDT/A,EDT1,EDT1/A,EDT2,EDT3,EDT6,EDT6/A,ED6,ED6/A,EMT,EMT/A,ENT,ENT/A,ENT2,EN6,EN6/A,ES3,ES3/A,ES4,ES4/A,VC2,VC2/A,VMQ,VMT,VMT/A,VS2,VS3,VS4,VS5,VS6,VS7,VTE2,VWC,VWE
13	88911-MJ3-000	GROMMET, FENDER	1	-	-	-----	EDS5,ENT,ENT/A,ENT2,EN6,EN6/A,VMQ,VMT,VMT/A,VWC,VWE
14	90624-SB0-003	CLIP, WIRE HARNESS	1	-	-	-----	EDS5
15	94050-05000	NUT, FLANGE, 5MM	6	-	-	-----	EDE2,EDE2/A,EDN,EDN2,EDN2/A,EDS,EDS1,EDS1/A,EDS2,EDS2/A,EDS3,EDS4,EDS5,EDS6,EDS6/A,EDT,EDT/A,EDT1,EDT1/A,EDT2,EDT3,EDT6,EDT6/A,ED6,ED6/A,EMT,EMT/A,ENT,ENT/A,ENT2,EN6,EN6/A,ES3,ES3/A,ES4,ES4/A,VC2,VC2/A,VMQ,VMT,VMT/A,VS2,VS3,VS4,VS5,VS6,VS7,VTE2,VWC,VWE

2

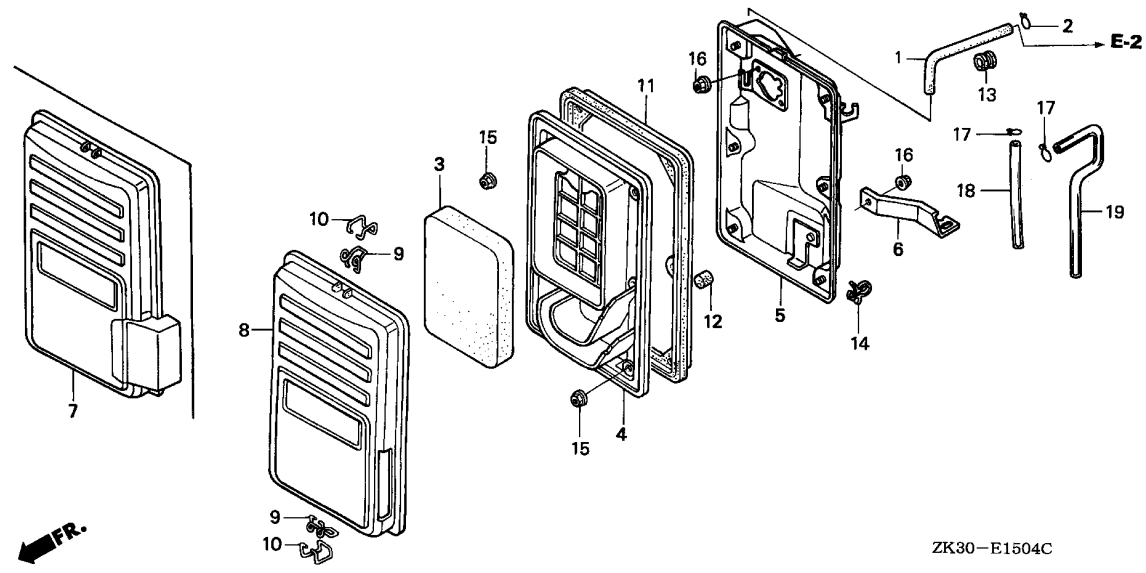

ZK30-E1504C

Ref. No.	Part No.	Description	Reqd. QTY			Serial No.	Parts catalogue code
			GX	340K1			
			(1)	(2)	(3)		
16	94050-06000	NUT, FLANGE, 6MM .....	3	-	-	-----	EDE2,EDE2/A,EDN,EDN2,EDN2/A,EDS,EDS1,EDS1/A,EDS2,EDS2/A,EDS3,EDS4,EDS5,EDS6,EDS6/A,EDT,EDT/A,EDT1,EDT1/A,EDT2,EDT3,EDT6,EDT6/A,ED6,ED6/A,ENT,ENT/A,ENT2,EN6,EN6/A,ES4,ES4/A,VC2,VC2/A,VMQ,VMT,VMT/A,VS2,VS4,VS5,VS6,VS7,VTE2,VVC,VVE
17	95002-45000	CLIP, TUBE (C8) .....	2	-	-	-----	EDS5
18	95003-09023-31	TUBE, VINYL, 4.5X8X230 (95003-09001-60M)	1	-	-	-----	EDS5
19	95003-09038-31	TUBE, VINYL, 4.5X8X380 (95003-09001-60M)	1	-	-	-----	EDS5



E-15-5

AIR CLEANER(6)

2-B 6

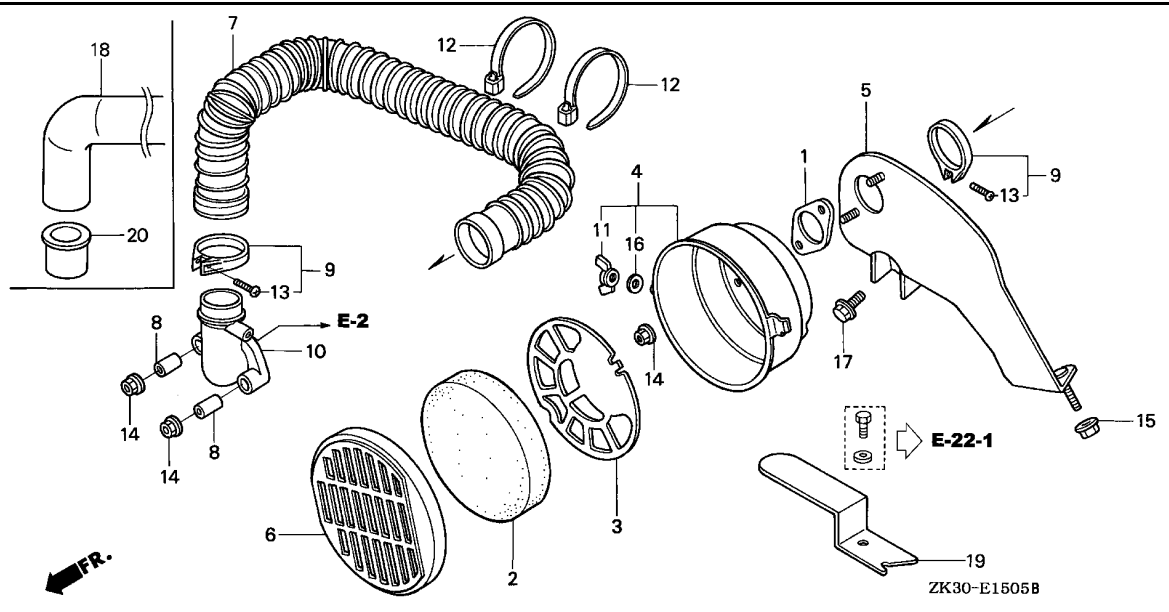

Ref. No.	L.O.N.	(Relative ref. Number) Description	F.R.T.
1	3121D9	PACKING, AIR CLEANER .....	0.1
2	3121B8	ELEMENT, AIR CLEANER .....	0.1
.INCLUDES: Air cleaner-inspection			
4	3121H1	CASE, AIR CLEANER(A) .....	0.1
5	3121G4	STAY, AIR CLEANER .....	0.2
7		(18)	
	3121D1	HOSE, AIR CLEANER .....	0.1
10	3121B4	ELBOW, AIR CLEANER .....	0.1

2

Ref. No.	Part No.	Description	Reqd. QTY			Serial No.	Parts catalogue code
			GX	340K1	(3)		
1	16269-890-800	PACKING, AIR CLEANER .....	1	-	-	ZK1,ZK1/A	
2	17211-883-010	ELEMENT, AIR CLEANER .....	1	-	-	ZK1,ZK1/A	
3	17212-ZE3-L60	GRID, AIR CLEANER .....	1	-	-	ZK1,ZK1/A	
4	17220-ZE3-L60	CASE COMP., AIR CLEANER .....	1	-	-	2343602 ZK1	
	17220-ZE3-L61	.....	1	-	-	ZK1/A	
		.....	1	-	-	2343603 ZK1	
5	17222-ZE3-L60	STAY COMP., AIR CLEANER .....	1	-	-	ZK1,ZK1/A	
6	17231-883-020	COVER, AIR CLEANER .....	1	-	-	ZK1,ZK1/A	
7	17237-ZE2-S00	HOSE, AIR CLEANER .....	1	-	-	2767218 ZK1	
8	17238-ZE7-010	COLLAR, AIR CLEANER .....	2	-	-	ZK1,ZK1/A	
9	17255-ZE3-L60	BAND, AIR CLEANER CONNECTING TUBE (38)	2	-	-	2790257 ZK1	
	17255-ZE3-L61	BAND, AIR CLEANER CONNECTING TUBE (36)	2	-	-	ZK1/A	
		.....	2	-	-	2790258 ZK1	
10	17410-ZA0-701	ELBOW COMP., AIR CLEANER .....	1	-	-	ZK1,ZK1/A	
11	90325-044-000	NUT, TOOL BOX SETTING .....	1	-	-	ZK1,ZK1/A	
12	90674-ZE3-L60	BAND, WIRE .....	2	-	-	2375016 2767218 ZK1	
13	93500-04025-0G	SCREW, PAN, 4X25 .....	2	-	-	ZK1,ZK1/A	
14	94050-06000	NUT, FLANGE, 6MM .....	4	-	-	ZK1,ZK1/A	
15	94050-08000	NUT, FLANGE, 8MM .....	1	-	-	ZK1,ZK1/A	
16	94101-06000	WASHER, PLAIN, 6MM .....	1	-	-	ZK1,ZK1/A	
17	95701-08030-00	BOLT, FLANGE, 8X30 .....	1	-	-	ZK1,ZK1/A	
18	17237-ZE3-L60	HOSE, AIR CLEANER .....	1	-	-	ZK1/A	
		.....	1	-	-	2767219 ZK1	



E-15-5

AIR CLEANER(6)

2-B 7

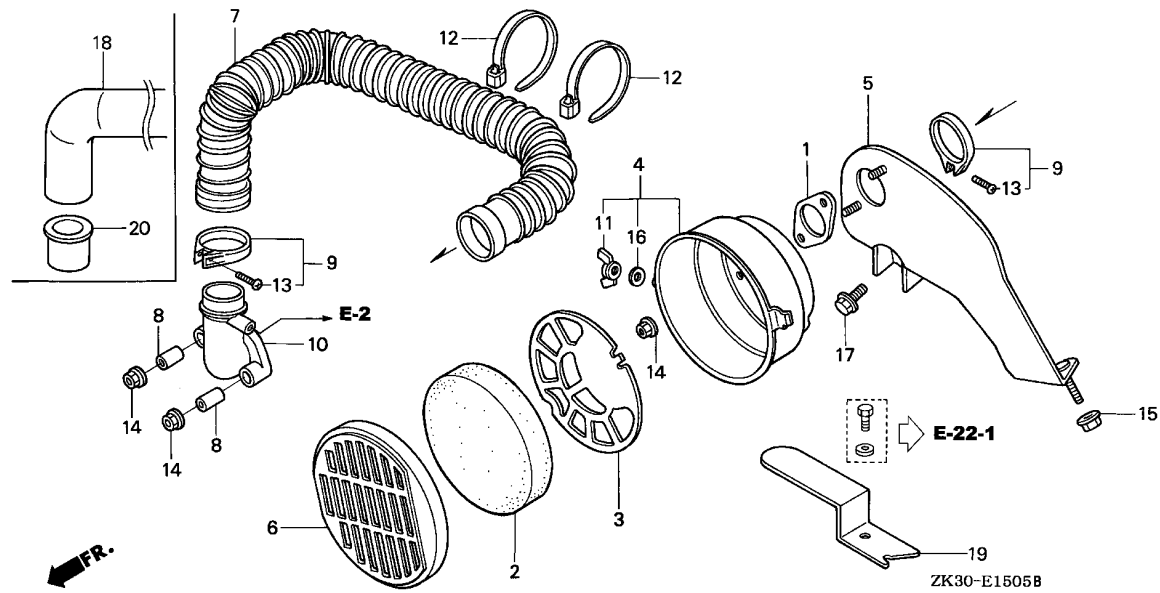

Ref. No.	Part No.	Description	Reqd. QTY			Serial No.	Parts catalogue code
			GX	340K1			
			(1)	(2)	(3)		
19	17234-ZE3-L60	PLATE SET, AIR CLEANER .....	1	-	-	-----	ZK1/A
			1	-	-	2767219	ZK1
20	17238-ZE3-L60	COLLAR, AIR CLEANER .....	1	-	-	-----	ZK1/A
			1	-	-	2767219	ZK1

2

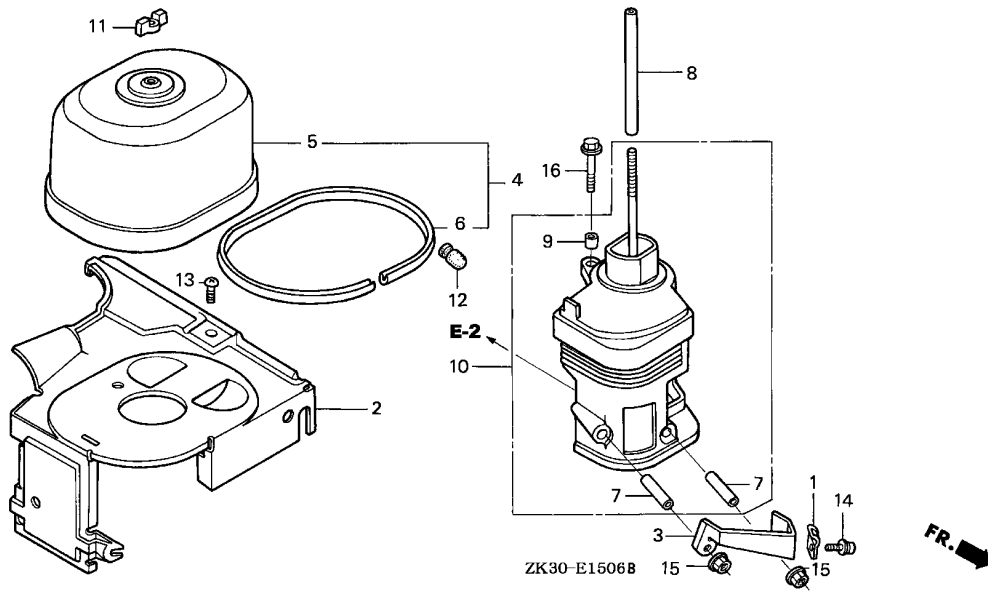

Ref. No.	L.O.N.	(Relative ref. Number) Description	F.R.T.
2	4141J6	COVER, AIR CLEANER CONTROL ...	0.1
6	3121E9	SEAL, AIR CLEANER COVER .....	0.1
10	3121B4	ELBOW, AIR CLEANER .....	0.1

Ref. No.	Part No.	Description	Reqd. QTY			Serial No.	Parts catalogue code
			GX	340K1			
			(1)	(2)	(3)		
1	16582-883-300	HOLDER, CONTROL CABLE .....	1	-	-	-----	LWD1,LWD1/A
2	16591-ZE3-H00	COVER, CONTROL .....	1	-	-	-----	LWD1,LWD1/A
3	16597-ZE2-780	STAY COMP., WIRE HOLDER .....	1	-	-	-----	LWD1,LWD1/A
4	17230-ZE3-H50	COVER, AIR CLEANER .....	1	-	-	-----	LWD1,LWD1/A
5	17230-ZE3-000	COVER, AIR CLEANER (STD.) ...	1	-	-	-----	LWD1,LWD1/A
6	17233-ZE3-H60	RUBBER, AIR CLEANER COVER ...	1	-	-	-----	LWD1,LWD1/A
7	17238-ZE2-310	COLLAR, AIR CLEANER .....	2	-	-	-----	LWD1,LWD1/A
8	17238-ZE3-H00	COLLAR, AIR CLEANER .....	1	-	-	-----	LWD1,LWD1/A
9	17239-ZE1-000	COLLAR B, AIR CLEANER .....	1	-	-	-----	LWD1,LWD1/A
10	17410-ZE3-010	ELBOW COMP., AIR CLEANER ....	1	-	-	-----	LWD1,LWD1/A
11	90325-044-000	NUT, TOOL BOX SETTING .....	1	-	-	-----	LWD1,LWD1/A
12	90899-422-610	PLUG, CONE TYPE .....	1	-	-	-----	LWD1,LWD1/A
13	93500-06008-0G	SCREW, PAN, 6X8 .....	1	-	-	-----	LWD1,LWD1/A
14	93892-05016-00	SCREW-WASHER, 5X16 .....	1	-	-	-----	LWD1,LWD1/A
15	94050-06000	NUT, FLANGE, 6MM .....	2	-	-	-----	LWD1,LWD1/A
16	95701-06035-08	BOLT, FLANGE, 6X35 .....	1	-	-	-----	LWD1,LWD1/A

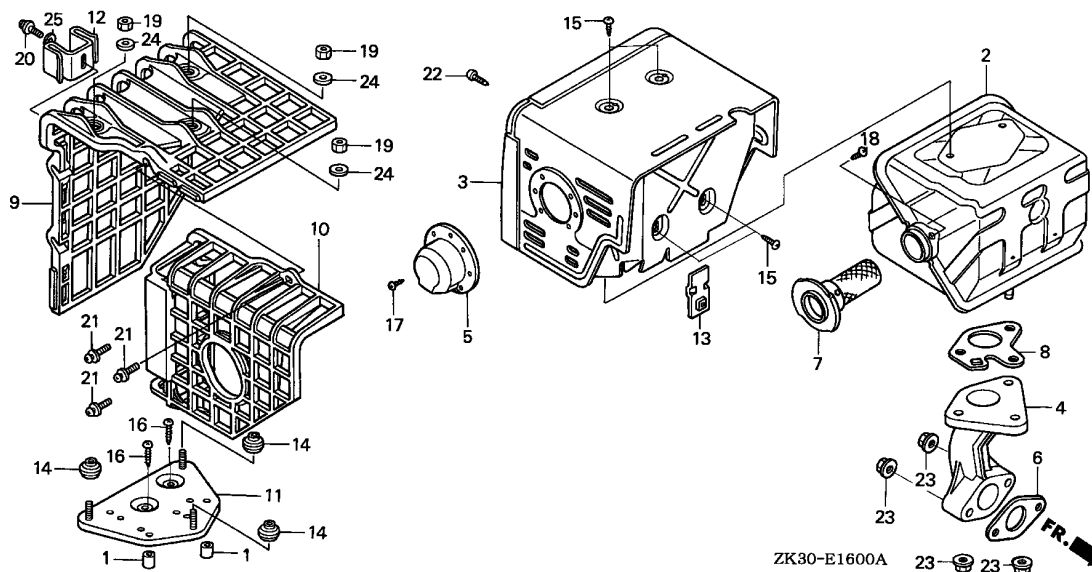

Ref. No.	L.O.N.	(Relative ref. Number) Description	F.R.T.
2	3131C5	MUFFLER, EXHAUST .....	0.2
3	3131D6	PROTECTOR, EXHAUST MUFFLER ...	0.2
4	3131C9	PIPE, EXHAUST .....	0.2
6	3131B5	GASKET, EXHAUST PIPE .....	0.2
7	3131A1	ARRESTER, SPARK .....	0.2
		.INCLUDES: Spark arrester check	
8	3131B4	GASKET, EXHAUST MUFFLER .....	0.2
9	3131A7	COVER, EXHAUST MUFFLER .....	0.1
10	3131A6	COVER, EXHAUST MUFFLER :REAR ..	0.1
11	3131A2	BASE, EXHAUST MUFFLER COVER ..	0.2

Ref. No.	Part No.	Description	Reqd. QTY			Serial No.	Parts catalogue code	
			GX	340K1	(3)			
			(1)	(2)	(3)			
1	17233-896-701	COLLAR, AIR CLEANER CASE ....	(2)	-	-	-----	QXB/A,QXB7,QXB7/A,SXB/A,SXB7,SXB7/A,SXEB/A,VSH7,VXB/A,VXB7,VXB7/A VXEB/A,VXE7,VXE7/A	
2	18310-ZE2-W60	MUFFLER COMP. (100DB) .....	(2)	-	-	2338524	-----	QXB,SXB,SXEB,VNG1,VNG2,VXB,VXEB,VXG
	18310-ZE2-W61	.....	1	-	-	3030997	-----	QXEB,SHT,VNG,VNG1,VNG2,VXB2,VXG
			1	-	-	-----	-----	QXB,SXB,SXEB,VWC2,VWS2,VXB,VXEB
3	18320-ZE2-W60	PROTECTOR COMP., MUFFLER ....	1	-	-	3030998	-----	QXB/A,QXB7,QXB7/A,SXB/A,SXB7,SXB7/A,SXEB/A,VSH7,VWC2/A,VWS2/A VXB/A,VXB7,VXB7/A,VXEB/A,VXE7,VXE7/A
	18320-ZF6-W00	PROTECTOR COMP., MUFFLER	1	-	-	2338523	-----	QXB,SXB,SXEB,VWC2,VWS2,VXB,VXEB
		(100DB)	1	-	-	-----	-----	QXB,QXEB,SXB,SXEB,VNG,VXB,VXEB,VXG
	18320-ZE2-W61	PROTECTOR COMP., MUFFLER ....	1	-	-	2360327	-----	SHT,VNG1,VNG2
	18320-ZF6-W01	PROTECTOR COMP., MUFFLER	1	-	-	2338524	-----	QXB/A,SXB/A,SXEB/A,VWC2,VWC2/A,VWS2,VWS2/A,VXB/A,VXB2,VXEB/A
		(100DB)	1	-	-	-----	-----	QXB,QXEB,SXB,SXEB,VNG,VXB,VXEB,VXG
4	18330-ZE2-W00	PIPE, EX. ....	1	-	-	2360328	-----	QXB7,QXB7/A,SXB7,SXB7/A,VSH7,VXB7,VXB7/A,VXE7,VXE7/A
			1	-	-	-----	-----	SHT,VNG1,VNG2
			1	-	-	-----	-----	QXB,QXB/A,QXB7,QXB7/A,QXEB,SHT,SXB,SXB/A,SXB7,SXB7/A,SXEB,SXEB/A VNG,VNG1,VNG2,VSH7,VWC2,VWC2/A,VWS2,VWS2/A,VXB,VXB/A,VXB2,VXB7 VXB7/A,VXEB,VXEB/A,VXE7,VXE7/A,VXG
5	18331-ZE3-810	CAP, MUFFLER .....	1	-	-	-----	-----	SHT
6	18333-ZE3-800	GASKET, EX. PIPE .....	1	-	-	2563593	-----	QXB,QXEB,SHT,SXB,SXEB,VNG,VNG1,VNG2,VWC2,VWS2,VXB,VXB2,VXEB,VXG
	18333-ZK6-Y00	.....	1	-	-	2563594	-----	QXEB,SHT,VNG,VNG1,VNG2,VXB2,VXG
			1	-	-	3030997	-----	QXB,SXB,SXEB,VWC2,VWS2,VXB,VXEB
	18333-ZF6-W01	.....	1	-	-	-----	-----	QXB/A,QXB7,QXB7/A,SXB/A,SXB7,SXB7/A,SXEB/A,VSH7,VWC2/A,VWS2/A VXB/A,VXB7,VXB7/A,VXEB/A,VXE7,VXE7/A
			1	-	-	3030998	-----	QXB,SXB,SXEB,VWC2,VWS2,VXB,VXEB



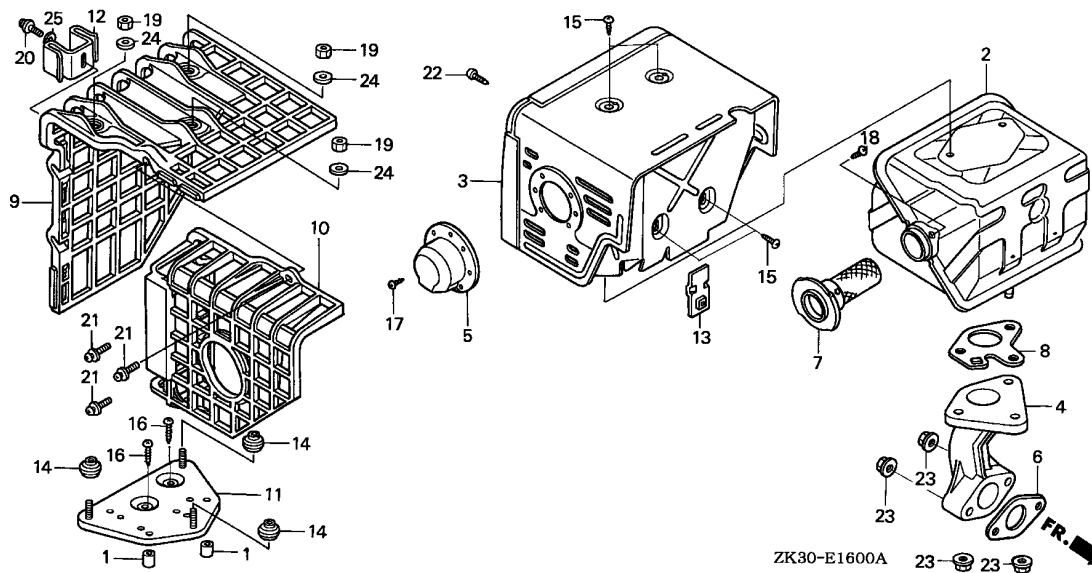

Ref. No.	Part No.	Description	Reqd. QTY			Serial No.	Parts catalogue code	
			GX	(1)	(2)			(3)
7	18355-ZE2-W00	ARRESTER, SPARK .....	1	-	-	-----	QXB,QXB/A,QXB7,QXB7/A,QXEB,SHT,SXB,SXB/A,SXB7,SXB7/A,SXEB,SXEB/A,VNG,VNG1,VNG2,VSH7,VWC2,VWC2/A,VWS2,VWS2/A,VXB,VXB/A,VXB2,VXB7,VXB7/A,VXEB,VXEB/A,VXE7,VXE7/A,VXG	
8	18381-ZE2-W10	GASKET, MUFFLER (ARRESTER) ..	1	-	-	-----	QXB,QXB/A,QXB7,QXB7/A,QXEB,SHT,SXB,SXB/A,SXB7,SXB7/A,SXEB,SXEB/A,VNG,VNG1,VNG2,VSH7,VWC2,VWC2/A,VWS2,VWS2/A,VXB,VXB/A,VXB2,VXB7,VXB7/A,VXEB,VXEB/A,VXE7,VXE7/A,VXG	
9	18433-ZF6-W40	COVER COMP., MUFFLER .....	(1)	-	-	-----	QXB/A,QXB7,QXB7/A,SXB/A,SXB7,SXB7/A,SXEB/A,VSH7,VXB/A,VXB7,VXB7/A,VXEB/A,VXE7,VXE7/A	
10	18434-ZF6-W40	COVER COMP., RR. MUFFLER ....	(1)	-	-	2338524	-----	QXB,SXB,SXEB,VNG1,VNG2,VXB,VXEB,VXG
			(1)	-	-	-----	-----	QXB/A,QXB7,QXB7/A,SXB/A,SXB7,SXB7/A,SXEB/A,VSH7,VXB/A,VXB7,VXB7/A,VXEB/A,VXE7,VXE7/A
			(1)	-	-	2338524	-----	QXB,SXB,SXEB,VNG1,VNG2,VXB,VXEB,VXG
11	18436-ZH8-W40	BASE COMP., MUFFLER COVER ...	(1)	-	-	-----	-----	QXB/A,QXB7,QXB7/A,SXB/A,SXB7,SXB7/A,SXEB/A,VSH7,VXB/A,VXB7,VXB7/A,VXEB/A,VXE7,VXE7/A
			(1)	-	-	2338524	-----	QXB,SXB,SXEB,VNG1,VNG2,VXB,VXEB,VXG
12	18437-ZF6-W40	STAY, MUFFLER COVER .....	(1)	-	-	-----	-----	QXB,QXB/A,QXB7,QXB7/A,SXB,SXB/A,SXB7,SXB7/A,SXEB,SXEB/A,VNG1,VNG2,VSH7,VXB,VXB/A,VXB7,VXB7/A,VXEB,VXEB/A,VXE7,VXE7/A,VXG
13	18438-ZF6-W40	PLATE, SET .....	(1)	-	-	-----	-----	QXB,QXB/A,QXB7,QXB7/A,SXB,SXB/A,SXB7,SXB7/A,SXEB,SXEB/A,VNG1,VNG2,VSH7,VXB,VXB/A,VXB7,VXB7/A,VXEB,VXEB/A,VXE7,VXE7/A,VXG
14	18466-ZH8-W40	SPACER, MUFFLER COVER .....	(3)	-	-	-----	-----	QXB/A,QXB7,QXB7/A,SXB/A,SXB7,SXB7/A,SXEB/A,VSH7,VXB/A,VXB7,VXB7/A,VXEB/A,VXE7,VXE7/A
			(3)	-	-	2338524	-----	QXB,SXB,SXEB,VNG1,VNG2,VXB,VXEB,VXG
15	90050-ZE1-000	SCREW, TAPPING, 5X8 .....	4	-	-	-----	-----	QXB,QXB/A,QXB7,QXB7/A,QXEB,SHT,SXB,SXB/A,SXB7,SXB7/A,SXEB,SXEB/A,VNG,VNG1,VNG2,VSH7,VWC2,VWC2/A,VWS2,VWS2/A,VXB,VXB/A,VXB2,VXB7,VXB7/A,VXEB,VXEB/A,VXE7,VXE7/A,VXG

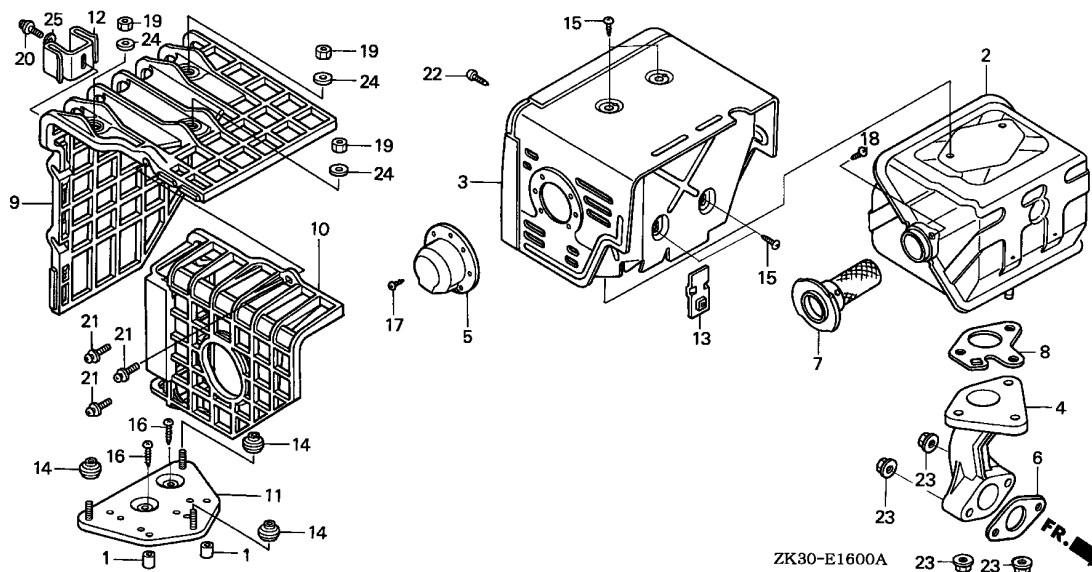

Ref. No.	Part No.	Description	Reqd. QTY			Serial No.	Parts catalogue code
			GX	(1)	(2)		
16	90050-ZH8-W40	SCREW, TAPPING, 5X25	(2)	-	-	-	QXB/A, QXB7, QXB7/A, SXB/A, SXB7, SXB7/A, SXEB/A, VSH7, VXB/A, VXB7, VXB7/A, VXEB/A, VXE7, VXE7/A
17	90055-ZE1-000	SCREW, TAPPING, 4X6	(2)	-	-	2337465	QXB, SXB, SXEB, VNG1, VNG2, VXB, VXEB, VXG
18	90055-ZE1-000	SCREW, TAPPING, 4X6	3	-	-	-	SHT
	90050-ZE1-000	SCREW, TAPPING, 5X8	1	-	-	2324692	QXB, QXEB, SHT, SXB, SXEB, VNG, VNG1, VNG2, VXB, VXEB, VXG
			1	-	-	-	QXB/A, QXB7, QXB7/A, SXB/A, SXB7, SXB7/A, SXEB/A, VSH7, VWC2, VWC2/A, VWS2, VWS2/A, VXB/A, VXB2, VXB7, VXB7/A, VXEB/A, VXE7, VXE7/A
19	90302-KF9-900	NUT, HEX., 5MM	1	-	-	2324693	QXB, QXEB, SHT, SXB, SXEB, VNG, VNG1, VNG2, VXB, VXEB, VXG
			(3)	-	-	-	QXB/A, QXB7, QXB7/A, SXB/A, SXB7, SXB7/A, SXEB/A, VSH7, VXB/A, VXB7, VXB7/A, VXEB/A, VXE7, VXE7/A
20	93891-05012-00	SCREW-WASHER, 5X12	(3)	-	-	2337465	QXB, SXB, SXEB, VNG1, VNG2, VXB, VXEB, VXG
			(1)	-	-	-	QXB, QXB/A, QXB7, QXB7/A, SXB, SXB/A, SXB7, SXB7/A, SXEB, SXEB/A, VNG1, VNG2, VSH7, VXB, VXB/A, VXB7, VXB7/A, VXEB, VXEB/A, VXE7, VXE7/A, VXG
21	93891-06020-07	SCREW-WASHER, 6X20	(3)	-	-	-	QXB/A, QXB7, QXB7/A, SXB/A, SXB7, SXB7/A, SXEB/A, VSH7, VXB/A, VXB7, VXB7/A, VXEB/A, VXE7, VXE7/A
			(3)	-	-	2337465	QXB, SXB, SXEB, VNG1, VNG2, VXB, VXEB, VXG
22	93901-360J0	SCREW, TAPPING, 6X10	1	-	-	2188189	QXB, QXEB, SXB, SXEB, VNG, VNG1, VNG2, VXB, VXEB
	90006-ZE2-000		1	-	-	-	QXB/A, QXB7, QXB7/A, SHT, SXB/A, SXB7, SXB7/A, SXEB/A, VSH7, VWC2, VWC2/A, VWS2, VWS2/A, VXB/A, VXB2, VXB7, VXB7/A, VXEB/A, VXE7, VXE7/A, VXG
23	94050-08000	NUT, FLANGE, 8MM	1	-	-	2188190	QXB, QXEB, SXB, SXEB, VNG, VNG1, VNG2, VXB, VXEB
			5	-	-	-	QXB, QXB/A, QXB7, QXB7/A, QXEB, SHT, SXB, SXB/A, SXB7, SXB7/A, SXEB, SXEB/A, VNG, VNG1, VNG2, VSH7, VWC2, VWC2/A, VWS2, VWS2/A, VXB, VXB/A, VXB2, VXB7, VXB7/A, VXEB, VXEB/A, VXE7, VXE7/A, VXG
24	94103-05700	WASHER, PLAIN, 5MM	(3)	-	-	-	QXB/A, QXB7, QXB7/A, SXB/A, SXB7, SXB7/A, SXEB/A, VSH7, VXB/A, VXB7, VXB7/A, VXEB/A, VXE7, VXE7/A
			(3)	-	-	2337465	QXB, SXB, SXEB, VNG1, VNG2, VXB, VXEB, VXG
25	94111-05000	WASHER, SPRING, 5MM	(1)	-	-	-	QXB, QXB/A, QXB7, QXB7/A, SXB, SXB/A, SXB7, SXB7/A, SXEB, SXEB/A, VNG1, VNG2, VSH7, VXB, VXB/A, VXB7, VXB7/A, VXEB, VXEB/A, VXE7, VXE7/A, VXG

E-16-1

MUFFLER(2)

2-B12

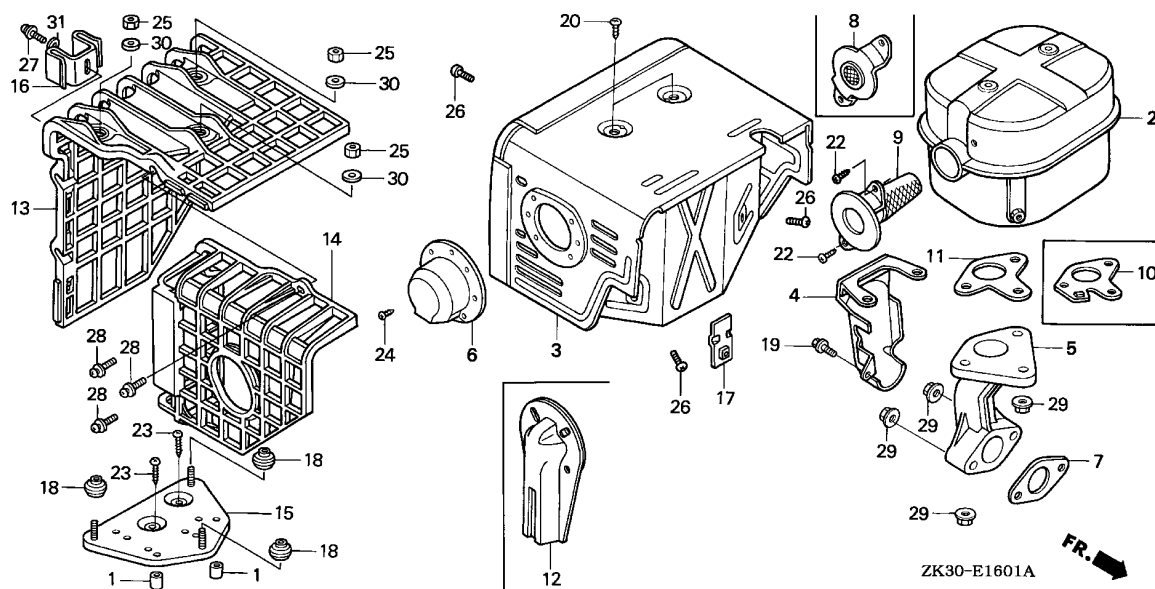

Ref. No.	L.O.N.	(Relative ref. Number) Description	F.R.T.
2	3131C5	MUFFLER, EXHAUST .....	0.2
3	3131D6	PROTECTOR, EXHAUST MUFFLER ...	0.2
5	3131C9	PIPE, EXHAUST .....	0.2
7	3131B5	GASKET, EXHAUST PIPE .....	0.2
8	3131G5	FLANGE, EXHAUST BAFFLE .....	0.2
9	3131A1	ARRESTER, SPARK .....	0.2
.INCLUDES: Spark arrester check (10)			
11	3131B4	GASKET, EXHAUST MUFFLER .....	0.2
13	3131A7	COVER, EXHAUST MUFFLER .....	0.1
14	3131A6	COVER, EXHAUST MUFFLER :REAR ..	0.1
15	3131A2	BASE, EXHAUST MUFFLER COVER ..	0.2

ZK30-E1601A



Ref. No.	Part No.	Description	Reqd. QTY GX 340K1 (1) (2) (3)	Serial No.	Parts catalogue code
1	17233-896-701	COLLAR, AIR CLEANER CASE ....	(2) - (2)	-----	LHQ4, LHQ4/A, LKE/A, LXE4, LXE4/A, LXQ4, LXQ4/A, PKX4, PKX4/A, QE, QE/A, QHQ4, QHQ4/A, QKA4, QKA4/A, QME0, QME0/A, QME8, QME8/A, QXC4, QXC4/A, QXE4, QXE4/A, QXQ4, QXQ4/A, SE, SE/A, SHQ4, SHQ4/A, SME0, SME0/A, SXE4, SXE4/A, SXQ4, SXQ4/A, VD16, VEB6, VXE4, VXQP, VXQ4, VXQ4/A
2	18310-ZE3-W00	MUFFLER COMP. ....	(2) - - 1 - -	2398545 -----	LKE BJ, EDK, EDN5, EDN5/A, ED7, ED8, ED8/A, ED9, ED9/A, EN, ES, ES1, ES1/A, ES2, ET, ETS, ETX, HA, HAQ, HA2, HA2/A, HH, HX, HX2, HX26, HX26/A, LH, LH/A, LHB1, LHB3, LHB3/A, LHB5, LHC, LHE, LHE/A, LHQ4, LHQ4/A, LJ, LJ/A, LJG, LJG/A, LJS, LJS/A, LJS1, LKE, LKE/A, LSX, LT, LT/A, LWD, LX, LX/A, LXE, LXE/A, LXE2, LXE2/A, LXE4, LXE4/A, LXE6, LXE8, LXE8/A, LXQ4, LXQ4/A, LXU, LXU/A, LXZ, LX2, LX2/A, LX26, LX26/A, PKX4, PX, PX/A, PXE8, PXE8/A, QA, QAC2, QAC2/A, QAE, QAE2, QAE2/A, QAE6, QAE6/A, QAG, QAG/A, QAH2, QAH2/A, QAP, QAPE, QAP2, QAP2/A, QAQ, QA2, QA2/A, QA26, QA26/A, QDW9, QDW9/A, QE, QE/A, QH, QH/A, QHB3, QHB3/A, QHB5, QHC, QHE, QHE/A, QHP1, QHP1/A, QHQ4, QHQ4/A, QH2, QKA4, QKA4/A, QL2, QME0, QME0/A, QME8, QME8/A, QMH, QMH/A, QMX2, QNE, QNE2, QNE2/A, QNE6, QNE9, QNE9/A, QNR2, QNR2/A, QNR6, QNR6/A, QN18, QP, QP/A, QPE2, QT, QT/A, QTC2, QTC2/A, QWH2, QWH2/A, QX, QX/A, QXC, QXC/A, QXC4, QXC4/A, QXC6, QXC6/A, QXC9, QXC9/A, QXE, QXE/A, QXE2, QXE4, QXE4/A, QXE6, QXE6/A, QXE8, QXE8/A, QXQ4, QXQ4/A, QXU, QXU/A, QX2, SDE, SE, SE/A, SH, SH/A, SHB1, SHB3, SHB3/A, SHE, SHEZ, SHQ4, SHQ4/A, SJ, SJ/A, SJG, SJG/A, SKE, SKE/A, SKZ, SKZ/A, SME0, SME0/A, SME2, SMX2, SMX2/A, STP, STP/A, STQ, STQ/A, STR, STR/A, SWX, SWX/A, SX, SX/A, SXE, SXE/A, SXE2, SXE4, SXE4/A, SXE8, SXE8/A, SXP, SXQ4, SXQ4/A, SXU, SXU/A, VA, VAD2, VAD2/A, VAH1, VAH2, VAW1, VA2, VA2/A, VDE, VDE2, VDE2/A, VE, VH, VHE, VH12, VH12/A, VH22, VH22/A, VMX, VWA, VWA2, VWE2, VWE2/A, VW12, VW12/A, VX, VX/A, VXA, VXE, VXE/A, VXE2, VXE2/A, VXE4, VXE6, VXE8, VXE8/A, VXX, VXQ4, VXQ4/A, VXU, VXU/A, VXU1, VXU1/A, VX16, VX16/A, VX8, VX8/A, YJ
	18310-ZE2-W60	MUFFLER COMP. (100DB) .....	- (1) 1 1 - -	-----	VD16, VEB6

2

Ref. No.	Part No.	Description	Reqd. QTY			Serial No.	Parts catalogue code	
			(1)	(2)	(3)			
3	18320-ZE3-W00	PROTECTOR COMP., MUFFLER	1	(1)	-	2337453	BJ, ED7, ED8, ED9, EN, ES, ES1, ET, ETS, ETX, HA, HAQ, HH, HX, LH, LHC, LHE, LJ, LJG, LKE, LX, LXE, LXZ, L1, PX, P1, QA, QAE, QAP, QAPE, QAA, QE, QH, QHE, QNE, QNE9, QP, QT, QX, QXC, QXE, Q1, SDE, SE, SH, SHE, SHEZ, SJ, SJG, STP, STQ, SWX, SX, SXE, SXP, S1, VA, VAH1, VAH2, VAW1, VDE, VE, VH, VHE, VWA, VX, VXA, VXE, VXU, VXU1, V1, YJ	
	18320-ZE3-W01	.....	1	-	-	-----	QHC	
			1	(1)	-	-----	EDK, EDN5, EDN5/A, ED8/A, ED9/A, ES1/A, ES2, HA2, HA2/A, HX2, HX26, HX26/A, LH/A, LHB1, LHB3, LHB3/A, LHB5, LHE/A, LHQ4, LHQ4/A, LJ/A, LJG/A, LJS, LJS/A, LJS1, LKE/A, LSX, LT, LT/A, LWD, LX/A, LXE/A, LXE2, LXE2/A, LXE4, LXE4/A, LXE6, LXE8, LXE8/A, LXQ4, LXQ4/A, LXU, LXU/A, LX2, LX2/A, LX26, LX26/A, L1/A, PKX4, PX/A, PXE8, PXE8/A, P1/A, QAC2, QAC2/A, QAE2, QAE2/A, QAE6, QAE6/A, QAG, QAG/A, QAH2, QAH2/A, QAP2, QAP2/A, QA2, QA2/A, QA26, QA26/A, QDW9, QDW9/A, QE/A, QH/A, QHB3, QHB3/A, QHB5, QHE/A, QHP1, QHP1/A, QHQ4, QHQ4/A, QH2, QKA4, QKA4/A, QL2, QMED, QMED/A, QME8, QME8/A, QMH, QMH/A, QMX2, QNE2, QNE2/A, QNE6, QNE9/A, QNR2, QNR2/A, QNR6, QNR6/A, QN18, QP/A, QPE2, QT/A, QTC2, QTC2/A, QWH2, QWH2/A, QX/A, QXC/A, QXC4, QXC4/A, QXC6, QXC6/A, QXC9, QXC9/A, QXE/A, QXE2, QXE4, QXE4/A, QXE6, QXE6/A, QXE8, QXE8/A, QXQ4, QXQ4/A, QXU, QXU/A, QX2, Q1/A, SE/A, SH/A, SHB1, SHB3, SHB3/A, SHQ4, SHQ4/A, SJ/A, SJG/A, SKE, SKE/A, SKZ, SKZ/A, SMEO, SMEO/A, SME2, SMX2, SMX2/A, STP/A, STQ/A, STR, STR/A, SWX/A, SX/A, SXE/A, SXE2, SXE4, SXE4/A, SXE8, SXE8/A, SXQ4, SXQ4/A, SXU, SXU/A, S1/A, VAD2, VAD2/A, VA2, VA2/A, VDE2, VDE2/A, VH12, VH12/A, VH22, VH22/A, VMX, VWA2, VWE2, VWE2/A, VW12, VW12/A, VX/A, VXE/A, VXE2, VXE2/A, VXE4, VXE6, VXE8, VXE8/A, VVK, VXQ4, VXQ4/A, VXU/A, VXU1/A, VX16, VX16/A, VX8, VX8/A	
			1	(1)	-	2337454	-----	BJ, ED7, ED8, ED9, EN, ES, ES1, ET, ETS, ETX, HA, HAQ, HH, HX, LH, LHC, LHE, LJ, LJG, LKE, LX, LXE, LXZ, L1, PX, P1, QA, QAE, QAP, QAPE, QAA, QE, QH, QHE, QNE, QNE9, QP, QT, QX, QXC, QXE, Q1, SDE, SE, SH, SHE, SHEZ, SJ, SJG, STP, STQ, SWX, SX, SXE, SXP, S1, VA, VAH1, VAH2, VAW1, VDE, VE, VH, VHE, VWA, VX, VXA, VXE, VXU, VXU1, V1, YJ
			-	-	-	-----	PKX4/A	
	18320-ZE2-W61	.....	1	-	-	-----	VD16, VEB6	
4	18323-ZE3-W40	PROTECTOR, EX. PIPE	1	-	-	-----	BJ, HA, HAQ, HA2, HA2/A, LJ, LJ/A, LJG, LJG/A, LJS, LJS/A, LJS1, LT, LT/A, LWD, QA, QAC2, QAC2/A, QAE, QAE2, QAE2/A, QAE6, QAE6/A, QAG, QAG/A, QAH2, QAH2/A, QAP, QAP2, QAP2/A, QAA, QA2, QA2/A, QA26, QA26/A, QL2, QNE, QNE2, QNE2/A, QNE6, QNE9, QNE9/A, QNR2, QNR2/A, QNR6, QNR6/A, QN18, SJ, SJ/A, SJG, SJG/A, SKE, SKE/A, SKZ, SKZ/A, STR, STR/A, VA, VAD2, VAD2/A, VAH1, VAH2, VAW1, VA2, VA2/A, VDE, VDE2, VDE2/A, VH12, VH12/A, VH22, VH22/A, VW12, VW12/A, YJ	
			-	(1)	-	-----		



E-16-1

MUFFLER(2)

2-B14

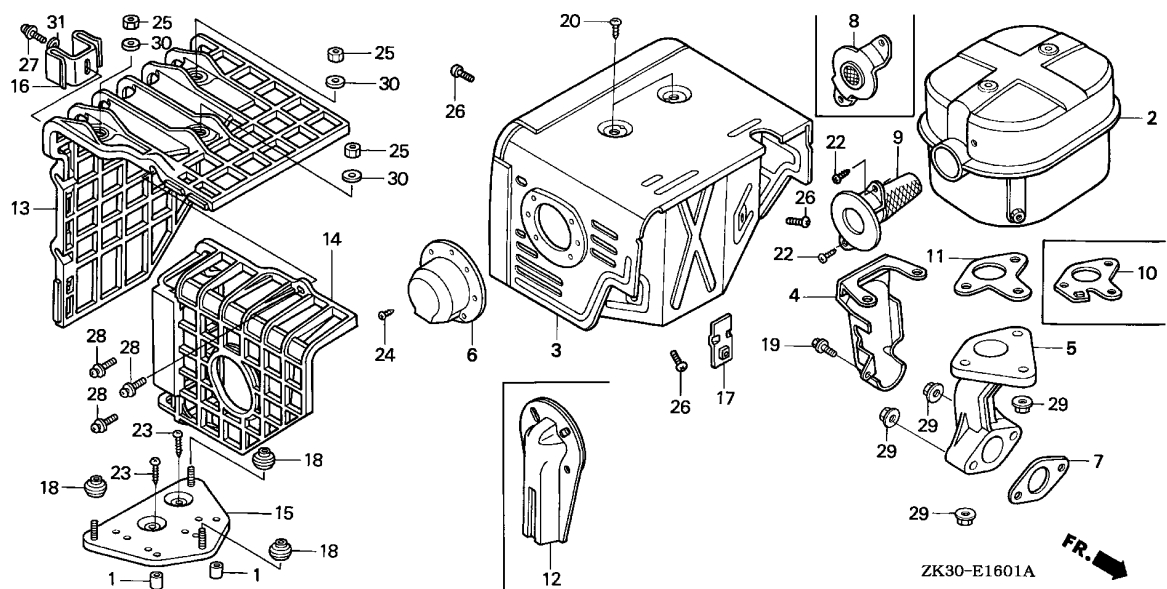

2

Ref. No.	Part No.	Description	Reqd. QTY			Serial No.	Parts catalogue code
			GX	340K1			
			(1)	(2)	(3)		
5	18330-ZE2-W00	PIPE, EX. ....	1	-	-	-----	BJ,EDK,EDN5,EDN5/A,ED7,ED8,ED8/A,ED9,ED9/A,EN,ES,ES1,ES1/A,ES2,ET ETS,ETX,HA,HAQ,HA2,HA2/A,HH,HX,HX2,HX26,HX26/A,LH,LH/A,LHB1,LHB3 LHB3/A,LHB5,LHC,LHE,LHE/A,LHQ4,LHQ4/A,LJ,LJ/A,LJG,LJG/A,LJS,LJS/A LJS1,LKE,LKE/A,LSX,LT,LT/A,LWD,LX,LX/A,LXE,LXE/A,LXE2,LXE2/A,LXE4 LXE4/A,LXE6,LXE8,LXE8/A,LXQ4,LXQ4/A,LXU,LXU/A,LXZ,LX2,LX2/A,LX26 LX26/A,PKX4,PX,PX/A,PXE8,PXE8/A,QA,QAC2,QAC2/A,QAE,QAE2,QAE2/A QAE6,QAE6/A,QAG,QAG/A,QA2,QA2/A,QAP,QAPE,QAP2,QAP2/A,QAQ,QA2 QA2/A,QA26,QA26/A,QDW9,QDW9/A,QE,QE/A,QH,QH/A,QHB3,QHB3/A,QHB5 QHC,QHE,QHE/A,QHP1,QHP1/A,QHQ4,QHQ4/A,QH2,QKA4,QKA4/A,QL2,QMED QMED/A,QME8,QME8/A,QMH,QMH/A,QMX2,QNE,QNE2,QNE2/A,QNE6,QNE9 QNE9/A,QNR2,QNR2/A,QNR6,QNR6/A,QN18,QP,QP/A,QPE2,QT,QT/A,QTC2 QTC2/A,QWH2,QWH2/A,QX,QX/A,QXC,QXC/A,QXC4,QXC4/A,QXC6,QXC6/A,QXC9 QXC9/A,QXE,QXE/A,QXE2,QXE4,QXE4/A,QXE6,QXE6/A,QXE8,QXE8/A,QXQ4 QXQ4/A,QXU,QXU/A,QX2,SDE,SE,SE/A,SH,SH/A,SHB1,SHB3,SHB3/A,SHE SHEZ,SHQ4,SHQ4/A,SJ,SJ/A,SJG,SJG/A,SKE,SKE/A,SKZ,SKZ/A,SME0 SME0/A,SME2,SMX2,SMX2/A,STP,STP/A,STQ,STQ/A,STR,STR/A,SWX,SWX/A SX,SX/A,SXE,SXE/A,SXE2,SXE4,SXE4/A,SXE8,SXE8/A,SXP,SXQ4,SXQ4/A SXU,SXU/A,VA,VAD2,VAD2/A,VAH1,VAH2,VAW1,VA2,VA2/A,VDE,VDE2,VDE2/A VD16,VE,VEB6,VH,VHE,VH12,VH12/A,VH22,VH22/A,VMX,VWA,VWA2,VWE2 VWE2/A,VW12,VW12/A,VX,VX/A,VXA,VXE,VXE/A,VXE2,VXE2/A,VXE4,VXE6 VXE8,VXE8/A,VXK,VXQ4,VXQ4/A,VXU,VXU/A,VXU1,VXU1/A,VX16,VX16/A,VX8 VX8/A,YJ
			-	(1)	1		





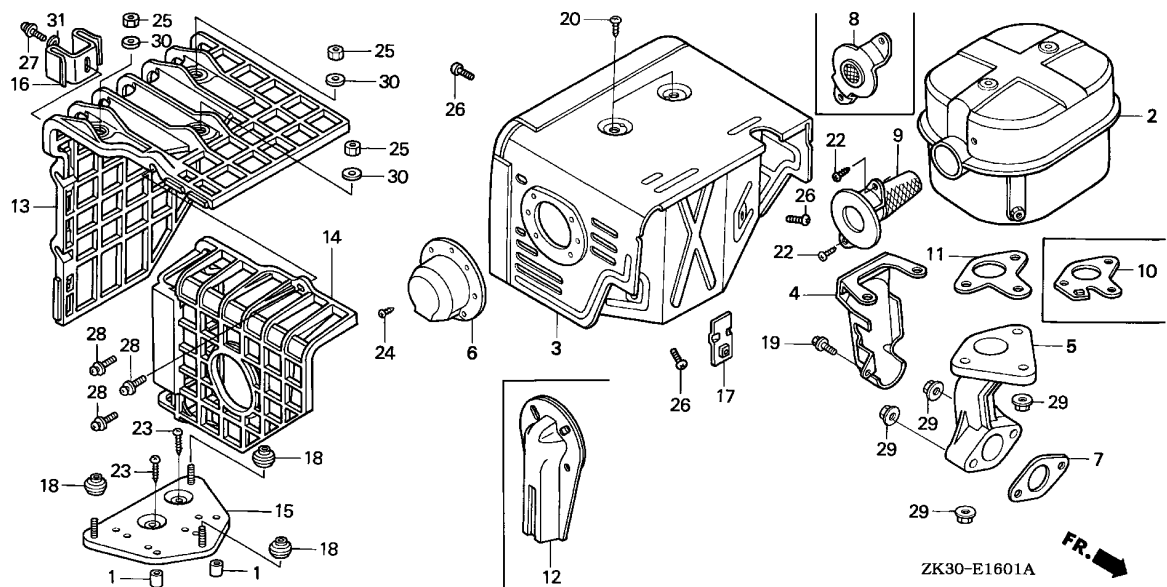

Ref. No.	Part No.	Description	Reqd. QTY			Serial No.	Parts catalogue code
			GX	340K1			
			(1)	(2)	(3)		
(7)	18333-ZF6-W01	GASKET, EX. PIPE .....	1	-	-	-----	EDK,EDN5/A,ED8/A,ED9/A,ES1/A,ES2,HA2/A,HX26/A,LH/A,LHB3/A,LHB5 LHE/A,LHQ4/A,LJ/A,LJG/A,LJS,LJS/A,LJS1,LKE/A,LT,LT/A,LWD,LX/A LX/A,LXE2/A,LXE4/A,LXE8/A,LXQ4/A,LXU/A,LX2/A,LX26/A,PX/A,PXE8/A QAC2,QAC2/A,QAE2/A,QAE6/A,QAG,QAG/A,QA2/A,QA26/A,QA26/A QDW9/A,QE/A,QH/A,QHB3/A,QHB5,QHE/A,QHP1/A,QHQ4/A,QKA4/A,QL2 QME0/A,QME8/A,QMH/A,QNE2/A,QNE9/A,QNR2/A,QNR6/A,QP/A,QT/A,QTC2/A QWH2,QWH2/A,QX/A,QXC/A,QXC4/A,QXC6/A,QXC9/A,QXE/A,QXE4/A,QXE6/A QXE8/A,QXQ4/A,QXU/A,SE/A,SH/A,SHB3/A,SHQ4/A,SJ/A,SJG/A,SKE/A SKZ/A,SMEO/A,SMX2/A,STP/A,STQ/A,STR/A,SWX/A,SX/A,SXE/A,SXE4/A SXE8/A,SXQ4/A,SXU/A,VAD2/A,VA2/A,VDE2/A,VH12/A,VH22/A,VWE2/A VW12/A,VX/A,VXE/A,VXE2/A,VXE8/A,VXK,VXQ4/A,VXU/A,VXU1/A,VX16/A VX8/A
			1	-	-	3030998	----- EDN5,ED7,ED8,ED9,ES1,HA2,HX2,LH,LHB3,LHE,LHQ4,LJ,LJG,LKE,LSX LX,LXE,LXE2,LXE4,LXE6,LXE8,LXQ4,LXU,LX2,LX26,PKX4,PX,PXE8,QAE2 QAE6,QA2,QAP2,QA2,QA26,QDW9,QE,QH,QHB3,QHE,QHP1,QHQ4,QKA4,QME0 QME8,QMH,QMX2,QNE2,QNR2,QNR6,QN18,QP,QPE2,QT,QTC2,QX,QXC,QXC4 QXC6,QXC9,QXE,QXE2,QXE4,QXE6,QXE8,QXQ4,QXU,SDE,SE,SH,SHB1,SHB3 SHE,SHQ4,SJ,SJG,SKE,SKZ,SMEO,SMX2,STP,STQ,STR,SWX,SX,SXE,SXE4 SXE8,SXQ4,SXU,VAD2,VA2,VDE2,VH,VH12,VH22,VMX,VMA2,VWE2,VW12,VX VXE,VXE2,VXE4,VXE8,VXQ4,VXU,VXU1,VX16,VX8
			1	-	-	3334264	----- QNE9
			1	-	-	3681345	----- PKX4/A
			-	-	1		

Ref. No.	Part No.	Description	Reqd. QTY			Serial No.	Parts catalogue code	
			(1)	(2)	(3)			
8	18336-ZE3-000	FLANGE COMP., BAFFLE .....	1	-	-	-----	BJ, EDN5, EDN5/A, ED7, ED8, ED8/A, EN, ES, ES1/A, ES2, ET, ETS, ETX, HH, HX, HX2, HX26, HX26/A, LH, LH/A, LHB1, LHB3, LHB3/A, LHB5, LHC, LHE, LHE/A, LHQ4, LHQ4/A, LJ, LJ/A, LJG, LJG/A, LKE, LKE/A, LSX, LT, LT/A, LWD, LX, LX/A, LXE, LXE/A, LXE2, LXE2/A, LXE4, LXE4/A, LXE6, LXE8, LXE8/A, LXQ4, LXQ4/A, LXU, LXU/A, LXZ, LX2, LX2/A, LX26, LX26/A, PKX4, PX, PX/A, PXE8, PXE8/A, QAPE, QH, QH/A, QHB3, QHB3/A, QHB5, QHC, QHE, QHE/A, QHP1, QHP1/A, QHQ4, QHQ4/A, QH2, QL2, QME0, QME0/A, QME8, QME8/A, QMH, QMH/A, QNE, QNE2, QNE2/A, QNE6, QNE9, QNE9/A, QNR2, QNR2/A, QNR6, QNR6/A, QN18, QP, QP/A, QPE2, QT, QT/A, QWH2, QWH2/A, QX, QX/A, QXC, QXC/A, QXC4, QXC4/A, QXC6, QXC6/A, QXC9, QXC9/A, QXE, QXE/A, QXE2, QXE4, QXE4/A, QXE6, QXE6/A, QXE8, QXE8/A, QXQ4, QXQ4/A, QXU, QXU/A, QX2, SDE, SH, SH/A, SHB1, SHB3, SHB3/A, SHE, SHEZ, SHQ4, SHQ4/A, SJ, SJ/A, SJG, SJG/A, SKE, SKE/A, SKZ, SKZ/A, SME0, SME0/A, STR, STR/A, SWX, SWX/A, SX, SX/A, SXE, SXE/A, SXE2, SXE4, SXE4/A, SXE8, SXE8/A, SXP, SXQ4, SXQ4/A, SXU, SXU/A, VH, VHE, VMX, VX, VX/A, VXA, VXE, VXE/A, VXE2, VXE2/A, VXE4, VXE6, VXE8, VXE8/A, VXX, VXQ4, VXQ4/A, VXU, VXU/A, VXU1, VXU1/A, VX16, VX16/A, VX8, VX8/A, YJ	
			1	-	-	2589846	-----	ES1
			-	(1)	1	-----	3681345	PKX4/A
9	18355-ZE3-010	ARRESTER, SPARK .....	1	-	-	-----	-----	EDK, ED9, ED9/A, HA, HAQ, HA2, HA2/A, LJS, LJS/A, LJS1, QA, QAC2, QAC2/A, QAE, QAE2, QAE2/A, QAE6, QAE6/A, QAG, QAG/A, QAH2, QAH2/A, QAP, QAP2, QAP2/A, QAQ, QA2, QA2/A, QA26, QA26/A, QDW9, QDW9/A, QE, QE/A, QKA4, QKA4/A, QMX2, QTC2, QTC2/A, SE, SE/A, SME2, SMX2, SMX2/A, STP, STP/A, STQ, STQ/A, VA, VAD2, VAD2/A, VAH1, VAH2, VAW1, VA2, VA2/A, VDE, VDE2, VDE2/A, VE, VH12, VH12/A, VH22, VH22/A, VWA, VWA2, VWE2, VWE2/A, VW12, VW12/A
			1	-	-	2589845	-----	ES1
			(1)	-	-	-----	-----	HH, HX, HX2, HX26, HX26/A, LSX, LX, LX/A, LXQ4, LXQ4/A, LXU, LXU/A, LX2, LX2/A, LX26, LX26/A, QAPE, QL2, QNE, QNE2, QNE2/A, QNE6, QNE9, QNE9/A, QNR2, QNR2/A, QNR6, QNR6/A, QN18, QPE2, QWH2, QWH2/A, QXC, QXC/A, QXC4, QXC4/A, QXC6, QXC6/A, QXC9, QXC9/A
	18355-ZE2-W00	.....	1	-	-	-----	-----	VD16, VEB6
10	18381-ZE2-W10	GASKET, MUFFLER (ARRESTER) ..	1	-	-	-----	-----	EDK, ED9, ED9/A, HA, HAQ, HA2, HA2/A, LJS, LJS/A, LJS1, QA, QAC2, QAC2/A, QAE, QAE2, QAE2/A, QAE6, QAE6/A, QAG, QAG/A, QAH2, QAH2/A, QAP, QAP2, QAP2/A, QAQ, QA2, QA2/A, QA26, QA26/A, QDW9, QDW9/A, QE, QE/A, QKA4, QKA4/A, QMX2, QTC2, QTC2/A, SE, SE/A, SME2, SMX2, SMX2/A, STP, STP/A, STQ, STQ/A, VA, VAD2, VAD2/A, VAH1, VAH2, VAW1, VA2, VA2/A, VDE, VDE2, VDE2/A, VD16, VE, VEB6, VH12, VH12/A, VH22, VH22/A, VWA, VWA2, VWE2, VWE2/A, VW12, VW12/A
			1	-	-	2589845	-----	ES1
			(1)	-	-	-----	-----	HH, HX, HX2, HX26, HX26/A, LSX, LX, LX/A, LXQ4, LXQ4/A, LXU, LXU/A, LX2, LX2/A, LX26, LX26/A, QAPE, QNE, QWH2, QWH2/A, QXC, QXC/A, QXC4, QXC4/A, QXC6, QXC6/A, QXC9, QXC9/A
			-	1	-	-----	-----	



E-16-1

MUFFLER(2)

2-C 2

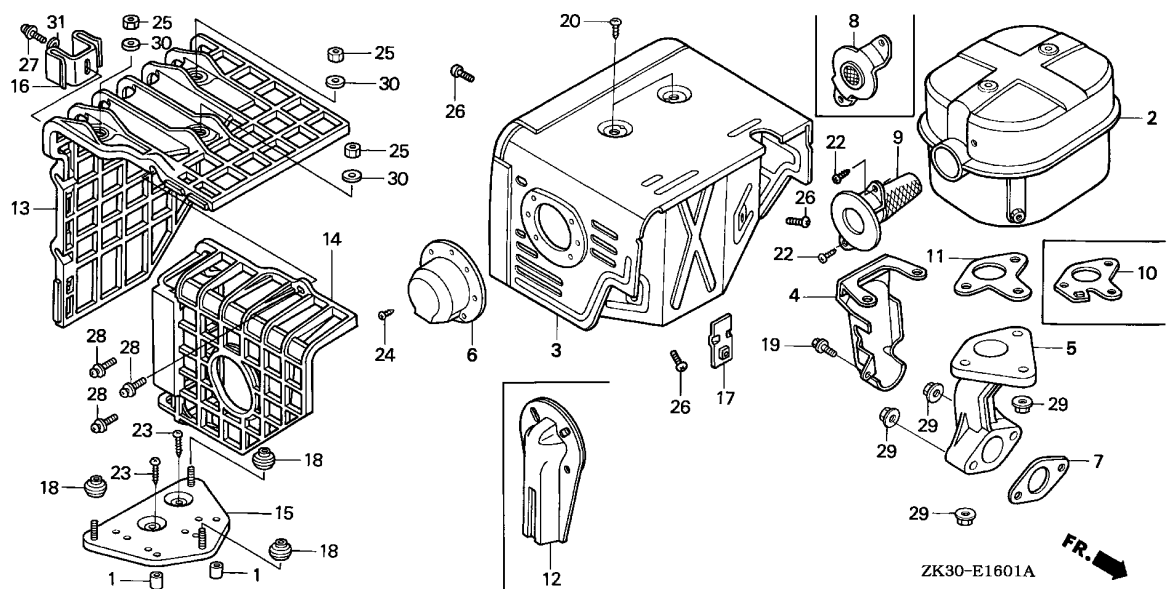

Ref. No.	Part No.	Description	Reqd. QTY GX 340K1 (1) (2) (3)	Serial No.	Parts catalogue code
11	18381-ZE2-800	GASKET, MUFFLER (NIPPON LEAKLESS)	1 - -	-----	BJ, EDN5, EDN5/A, ED7, ED8, ED8/A, EN, ES, ES1/A, ES2, ET, ETS, ETX, HH, HX, HX2, HX26, HX26/A, LH, LH/A, LHB1, LHB3, LHB3/A, LHB5, LHC, LHE, LHE/A, LHQ4, LHQ4/A, LJ, LJ/A, LJG, LJG/A, LKE, LKE/A, LSX, LT, LT/A, LWD, LX, LX/A, LXE, LXE/A, LXE2, LXE2/A, LXE4, LXE4/A, LXE6, LXE8, LXE8/A, LXQ4, LXQ4/A, LXU, LXU/A, LXZ, LX2, LX2/A, LX26, LX26/A, PKX4, PX, PX/A, PXE8, PXE8/A, QAPE, QH, QH/A, QHB3, QHB3/A, QHB5, QHC, QHE, QHE/A, QHP1, QHP1/A, QHQ4, QHQ4/A, QH2, QL2, QMED, QMED/A, QME8, QME8/A, QMH, QMH/A, QNE, QNE2, QNE2/A, QNE6, QNE9, QNE9/A, QNR2, QNR2/A, QNR6, QNR6/A, QN18, QP, QP/A, QPE2, QT, QT/A, QX, QX/A, QXC, QXC/A, QXC4, QXC4/A, QXC6, QXC6/A, QXC9, QXC9/A, QXE, QXE/A, QXE2, QXE4, QXE4/A, QXE6, QXE6/A, QXE8, QXE8/A, QXQ4, QXQ4/A, QXU, QXU/A, QX2, SDE, SH, SH/A, SHB1, SHB3, SHB3/A, SHE, SHEZ, SHQ4, SHQ4/A, SJ, SJ/A, SJG, SJG/A, SKE, SKE/A, SKZ, SKZ/A, SMEO, SMEO/A, STR, STR/A, SWX, SWX/A, SX, SX/A, SXE, SXE/A, SXE2, SXE4, SXE4/A, SXE8, SXE8/A, SXP, SXQ4, SXQ4/A, SXU, SXU/A, VH, VHE, VMX, VX, VX/A, VXA, VXE, VXE/A, VXE2, VXE2/A, VXE4, VXE6, VXE8, VXE8/A, VXX, VXQ4, VXQ4/A, VXU, VXU/A, VXU1, VXU1/A, VX16, VX16/A, VX8, VX8/A, YJ
			1 - -	2589846	----- ES1
			1 - -	3681345	----- PKX4/A
			(1) - -	-----	QWH2, QWH2/A
			- (1) 1		
12	18430-ZF6-W50	DEFLECTOR COMP., MUFFLER	(1) - -	-----	QE, QE/A, QKA4, QKA4/A, SE, SE/A
13	18433-ZF6-W40	COVER COMP., MUFFLER	(1) - (1)	-----	LHQ4, LHQ4/A, LKE/A, LXE4, LXE4/A, LXQ4, LXQ4/A, PKX4, PKX4/A, QE, QE/A, QHQ4, QHQ4/A, QKA4, QKA4/A, QMED, QMED/A, QME8, QME8/A, QXC4, QXC4/A, QXE4, QXE4/A, QXQ4, QXQ4/A, SE, SE/A, SHQ4, SHQ4/A, SMEO, SMEO/A, SXE4, SXE4/A, SXQ4, SXQ4/A, VD16, VEB6, VXE4, VXQP, VXQ4, VXQ4/A
			(1) - -	2398545	----- LKE

2

Ref. No.	Part No.	Description	Reqd. QTY			Serial No.	Parts catalogue code
			(1)	(2)	(3)		
14	18434-ZF6-W40	COVER COMP., RR. MUFFLER	(1)	-	(1)	-----	LHQ4, LHQ4/A, LKE/A, LXE4, LXE4/A, LXQ4, LXQ4/A, PKX4, PKX4/A, QE, QE/A, QHQ4, QHQ4/A, QKA4, QKA4/A, QMEO, QMEO/A, QME8, QME8/A, QXC4, QXC4/A, QXE4, QXE4/A, QXQ4, QXQ4/A, SE, SE/A, SHQ4, SHQ4/A, SMEO, SMEO/A, SXE4, SXE4/A, SXQ4, SXQ4/A, VD16, VEB6, VXE4, VXQP, VXQ4, VXQ4/A
15	18436-ZH8-W40	BASE COMP., MUFFLER COVER	(1)	-	(1)	2398545 -----	LKE
			(1)	-	(1)	-----	LHQ4, LHQ4/A, LKE/A, LXE4, LXE4/A, LXQ4, LXQ4/A, PKX4, PKX4/A, QE, QE/A, QHQ4, QHQ4/A, QKA4, QKA4/A, QMEO, QMEO/A, QME8, QME8/A, QXC4, QXC4/A, QXE4, QXE4/A, QXQ4, QXQ4/A, SE, SE/A, SHQ4, SHQ4/A, SMEO, SMEO/A, SXE4, SXE4/A, SXQ4, SXQ4/A, VD16, VEB6, VXE4, VXQP, VXQ4, VXQ4/A
16	18437-ZF6-W40	STAY, MUFFLER COVER	(1)	-	(1)	-----	LHQ4, LHQ4/A, LKE/A, LXE4, LXE4/A, LXQ4, LXQ4/A, PKX4, PKX4/A, QE, QE/A, QHQ4, QHQ4/A, QKA4, QKA4/A, QMEO, QMEO/A, QME8, QME8/A, QXC4, QXC4/A, QXE4, QXE4/A, QXQ4, QXQ4/A, SE, SE/A, SHQ4, SHQ4/A, SMEO, SMEO/A, SXE4, SXE4/A, SXQ4, SXQ4/A, VD16, VEB6, VXE4, VXQP, VXQ4, VXQ4/A
17	18438-ZF6-W40	PLATE, SET	(1)	-	(1)	2398545 -----	LKE
			(1)	-	(1)	-----	LHQ4, LHQ4/A, LKE/A, LXE4, LXE4/A, LXQ4, LXQ4/A, PKX4, PKX4/A, QE, QE/A, QHQ4, QHQ4/A, QKA4, QKA4/A, QMEO, QMEO/A, QME8, QME8/A, QXC4, QXC4/A, QXE4, QXE4/A, QXQ4, QXQ4/A, SE, SE/A, SHQ4, SHQ4/A, SMEO, SMEO/A, SXE4, SXE4/A, SXQ4, SXQ4/A, VD16, VEB6, VXE4, VXQP, VXQ4, VXQ4/A
18	18466-ZH8-W40	SPACER, MUFFLER COVER	(1)	-	(3)	2398545 -----	LKE
			(3)	-	(3)	-----	LHQ4, LHQ4/A, LKE/A, LXE4, LXE4/A, LXQ4, LXQ4/A, PKX4, PKX4/A, QE, QE/A, QHQ4, QHQ4/A, QKA4, QKA4/A, QMEO, QMEO/A, QME8, QME8/A, QXC4, QXC4/A, QXE4, QXE4/A, QXQ4, QXQ4/A, SE, SE/A, SHQ4, SHQ4/A, SMEO, SMEO/A, SXE4, SXE4/A, SXQ4, SXQ4/A, VD16, VEB6, VXE4, VXQP, VXQ4, VXQ4/A
19	90013-883-000	BOLT, FLANGE, 6X12(CT200)	(3)	-	(1)	2398545 -----	LKE
			1	-	(1)	-----	HAQ, HA2, HA2/A, LJS, LJS/A, LJS1, LT, LT/A, LWD, QAC2, QAC2/A, QAE2, QAE2/A, QAE6, QAE6/A, QAG, QAG/A, QAP2, QAP2/A, QAQ, QA2, QA2/A, QA26, QA26/A, QNE2, QNE2/A, QNE6, QNE9, QNE9/A, QNR2, QNR2/A, QNR6, QNR6/A, VAD2, VAD2/A, VA2, VA2/A, VDE2, VDE2/A, VH12, VH12/A, VH22, VH22/A, VW12, VW12/A
20	90050-ZE1-000	SCREW, TAPPING, 5X8	2	-	(1)	2644833 -----	HA, QA, QAE, QAP, QNE, QN18, VA, VAH1, VAH2, VAW1, VDE
			2	-	(2)	-----	BJ, EDK, EDN5, EDN5/A, ED7, ED8, ED8/A, ED9, ED9/A, EN, ES, ES1, ES1/A, ES2, ET, ETS, ETX, HA, HAQ, HA2, HA2/A, HH, HX, HX2, HX26, HX26/A, LH, LH/A, LHB1, LHB3, LHB3/A, LHB5, LHC, LHE, LHE/A, LHQ4, LHQ4/A, LJ, LJ/A, LJG, LJG/A, LJS, LJS/A, LJS1, LKE, LKE/A, LSX, LT, LT/A, LWD, LX, LX/A, LXE, LXE/A, LXE2, LXE2/A, LXE4, LXE4/A, LXE6, LXE8, LXE8/A, LXQ4, LXQ4/A, LXU, LXU/A, LXZ, LX2, LX2/A, LX26, LX26/A, PKX4, PX, PX/A, PXE8, PXE8/A, QA, QAC2, QAC2/A, QAE, QAE2, QAE2/A, QAE6, QAE6/A, QAG, QAG/A, QAH2, QAH2/A, QAP, QAPE, QAP2, QAP2/A, QAQ, QA2, QA2/A, QA26, QA26/A, QDW9, QDW9/A, QE, QE/A, QH, QH/A, QHB3, QHB3/A, QHB5, QHC, QHE, QHE/A, QHP1, QHP1/A, QHQ4, QHQ4/A, QH2, QKA4, QKA4/A, QL2, QMEO, QMEO/A, QME8, QME8/A, QMH, QMH/A, QMX2, QNE, QNE2, QNE2/A, QNE6, QNE9, QNE9/A, QNR2, QNR2/A, QNR6, QNR6/A, QN18, QP, QP/A, QPE2, QT, QT/A, QTC2, QTC2/A, QWH2, QWH2/A, QX, QX/A, QXC, QXC/A, QXC4, QXC4/A, QXC6, QXC6/A, QXC9, QXC9/A, QXE, QXE/A, QXE2, QXE4, QXE4/A, QXE6, QXE6/A, QXE8, QXE8/A, QXQ4, QXQ4/A, QXU, QXU/A, QX2, SDE, SE, SE/A, SH, SH/A, SHB1, SHB3, SHB3/A, SHE, SHEZ, SHQ4, SHQ4/A, SJ, SJ/A, SJG, SJG/A, SKE, SKE/A, SKZ, SKZ/A, SMEO, SMEO/A, SME2, SMX2, SMX2/A, STP, STP/A, STQ, STQ/A, STR, STR/A, SWX, SWX/A, SX, SX/A, SXE, SXE/A, SXE2, SXE4, SXE4/A, SXE8, SXE8/A, SXP, SXQ4, SXQ4/A, SXU, SXU/A, VA, VAD2, VAD2/A, VAH1, VAH2, VAW1, VA2, VA2/A, VDE, VDE2, VDE2/A, VD16, VE, VEB6, VH, VHE, VH12, VH12/A, VH22, VH22/A, VMX, VWA, VWA2, VWE2, VWE2/A, VW12, VW12/A, VX, VX/A, VXA, VXE, VXE/A, VXE2, VXE2/A, VXE4, VXE6, VXE8, VXE8/A, VXK, VXQ4, VXQ4/A, VXU, VXU/A, VXU1, VXU1/A, VX16, VX16/A, VX8, VX8/A, YJ
			2	-	(2)	3681345 -----	PKX4/A



E-16-1

MUFFLER(2)

2-C 4

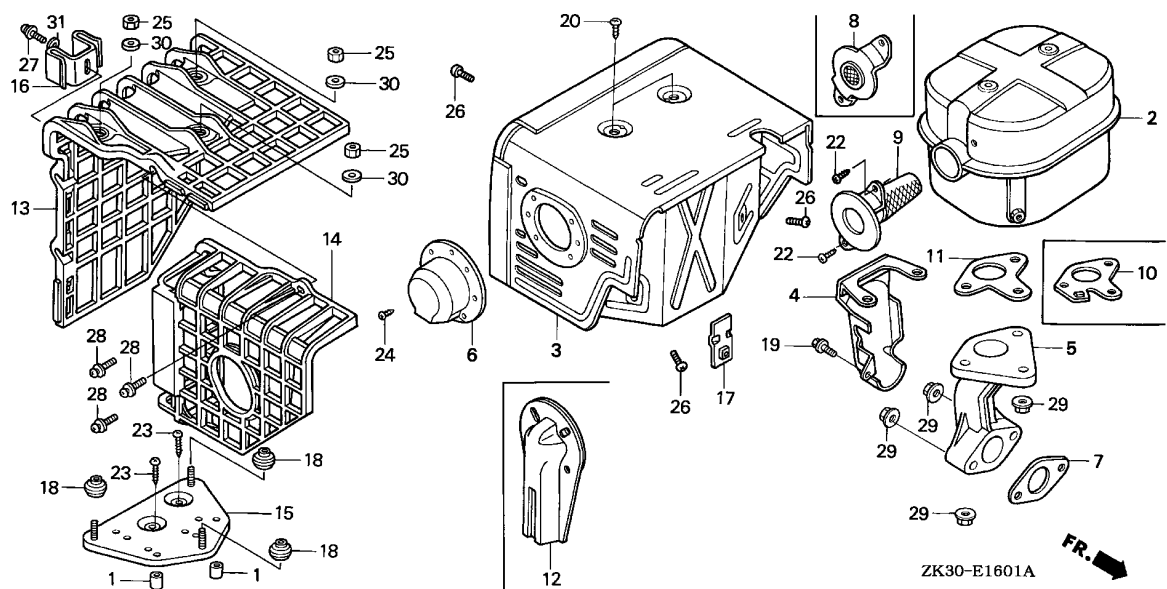

2

Ref. No.	Part No.	Description	Reqd. QTY			Serial No.	Parts catalogue code
			GX	(1)	(2)		
22	90050-ZE1-000	SCREW, TAPPING, 5X8	2	-	-	-----	BJ,EDK,ED9,ED9/A,ES2,LHB5,LJ,LJ/A,LJG,LJG/A,LJS,LJS/A,LJS1,LT LT/A,LWD,QA,QAC2,QAC2/A,QAE,QAE6,QAE6/A,QAG,QAG/A,QA2,QA2/A QA26,QA26/A,QE,QE/A,QHB5,QKA4,QKA4/A,QL2,QMX2,QNR2,QNR2/A,QTC2 QTC2/A,QWH2,QWH2/A,SDE,SE,SE/A,SJ,SJ/A,SJG,SJG/A,SKE,SKE/A,SKZ SKZ/A,STP,STP/A,STQ,STQ/A,STR,STR/A,VA,VDE2,VDE2/A,VD16,VE,VEB6 VW12,VW12/A,VXK,YJ
			2	-	-	-----	2589845 ES1
			2	-	-	-----	3681345 PKX4/A
			(2)	-	-	-----	HH,HX,HX26,HX26/A,LSX,LX,LX/A,LXQ4,LXQ4/A,LXU,LXU/A,LX26,LX26/A QNE,QNE6,QNR6,QNR6/A,QXC,QXC/A,QXC4,QXC4/A,QXC6,QXC6/A,SMX2 SMX2/A
23	90050-ZH8-W40	SCREW, TAPPING, 5X25	-	(2)	-	-----	LHQ4,LHQ4/A,LKE/A,LXE4,LXE4/A,LXQ4,LXQ4/A,PKX4,PKX4/A,QE,QE/A QH4,QH4/A,QKA4,QKA4/A,QME0,QME0/A,QME8,QME8/A,QXC4,QXC4/A,QXE4 QXE4/A,QXQ4,QXQ4/A,SE,SE/A,SHQ4,SHQ4/A,SME0,SME0/A,SXE4,SXE4/A SXQ4,SXQ4/A,VD16,VEB6,VXE4,VXQP,VXQ4,VXQ4/A
24	90055-ZE1-000	SCREW, TAPPING, 4X6	(2)	-	-	2398545	-----
			3	-	-	-----	LKE
			3	-	-	3439437	-----
			-	(3)	-	-----	HA,HAQ,HA2,HA2/A,LJS,LJS/A,LJS1,LT,LT/A,QA,QAC2,QAC2/A,QAE,QAE2 QAE2/A,QAE6,QAE6/A,QA2,QA2/A,QAP,QAPE,QAP2,QAP2/A,QAQ,QA2,QA2/A QA26,QA26/A,QE,QE/A,QHP1/A,QKA4,QKA4/A,QL2,QME8,QME8/A,QMH,QMH/A QNE,QNE2,QNE2/A,QNE6,QNE9,QNE9/A,QNR2,QNR2/A,QNR6,QNR6/A,QN18,QP QP/A,QPE2,QT,QT/A,QTC2,QTC2/A,QWH2,QWH2/A,SDE,SE,SE/A,SKE,SKE/A SKZ,SKZ/A,STP,STP/A,STQ,STQ/A,SWX,SWX/A,VA,VA2,VA2/A,VE

Ref. No.	Part No.	Description	Reqd. QTY			Serial No.	Parts catalogue code	
			(1)	(2)	(3)			
25	90302-KF9-900	NUT, HEX., 5MM .....	(3)	-	(3)	-----	LHQ4, LHQ4/A, LKE/A, LXE4, LXE4/A, LXQ4, LXQ4/A, PKX4, PKX4/A, QE, QE/A, QHQ4, QHQ4/A, QKA4, QKA4/A, QMEO, QMEO/A, QME8, QME8/A, QXC4, QXC4/A, QXE4, QXE4/A, QXQ4, QXQ4/A, SE, SE/A, SHQ4, SHQ4/A, SMEO, SMEO/A, SXE4, SXE4/A, SXQ4, SXQ4/A, VD16, VEB6, VXE4, VXQP, VXQ4, VXQ4/A	
			(3)	-	-	2398545	-----	LKE
26	93500-06006-4J	SCREW, PAN, 6X6 .....	3	(3)	-	-----	2167646	BJ, ED7, ED8, ED9, EN, ES, ES1, ET, ETS, ETX, HA, HH, HX, LH, LHC, LHE, LJ, LKE, LX, LXE, LXZ, L1, PX, P1, QA, QAE, QAP, QAPE, QE, QH, QHC, QHE, QNE, QP, QT, QX, QXC, QXE, Q1, SE, SH, SHE, SHEZ, SJ, STP, STQ, SWX, SX, SXE, SXP, S1, VA, VAH1, VAH2, VE, VH, VHE, VX, VXA, VXE, V1, YJ
	93500-06006-0B	.....	3	(3)	-	-----	-----	EDK, EDN5, EDN5/A, ED8/A, ED9/A, ES1/A, ES2, HAQ, HA2, HA2/A, HX2, HX26, HX26/A, LH/A, LHB1, LHB3, LHB3/A, LHB5, LHE/A, LHQ4, LHQ4/A, LJ/A, LJG, LJG/A, LJS, LJS/A, LJS1, LKE/A, LSX, LT, LT/A, LWD, LX/A, LXE/A, LXE2, LXE2/A, LXE4, LXE4/A, LXE6, LXE8, LXE8/A, LXQ4, LXQ4/A, LXU, LXU/A, LX2, LX2/A, LX26, LX26/A, L1/A, PKX4, PX/A, PXE8, PXE8/A, P1/A, QAC2, QAC2/A, QAE2, QAE2/A, QAE6, QAE6/A, QAG, QAG/A, QAH2, QAH2/A, QAP2, QAP2/A, QAQ, QA2, QA2/A, QA26, QA26/A, QDW9, QDW9/A, QE/A, QH/A, QHB3, QHB3/A, QHB5, QHE/A, QHP1, QHP1/A, QHQ4, QHQ4/A, QH2, QKA4, QKA4/A, QL2, QMEO, QMEO/A, QME8, QME8/A, QMH, QMH/A, QMX2, QNE2, QNE2/A, QNE6, QNE9, QNE9/A, QNR2, QNR2/A, QNR6, QNR6/A, QN18, QP/A, QPE2, QT/A, QTC2, QTC2/A, QWH2, QWH2/A, QX/A, QXC/A, QXC4, QXC4/A, QXC6, QXC6/A, QXC9, QXC9/A, QXE/A, QXE2, QXE4, QXE4/A, QXE6, QXE6/A, QXE8, QXE8/A, QXQ4, QXQ4/A, QXU, QXU/A, QX2, Q1/A, SDE, SE/A, SH/A, SHB1, SHB3, SHB3/A, SHQ4, SHQ4/A, SJ/A, SJG, SJG/A, SKE, SKE/A, SKZ, SKZ/A, SMEO, SMEO/A, SME2, SMX2, SMX2/A, STP/A, STQ/A, STR, STR/A, SWX/A, SX/A, SXE/A, SXE2, SXE4, SXE4/A, SXE8, SXE8/A, SXQ4, SXQ4/A, SXU, SXU/A, S1/A, VAD2, VAD2/A, VAW1, VA2, VA2/A, VDE, VDE2, VDE2/A, VH12, VH12/A, VH22, VH22/A, VMX, VWA, VWA2, VWE2, VWE2/A, VW12, VW12/A, VX/A, VXE/A, VXE2, VXE2/A, VXE4, VXE6, VXE8, VXE8/A, VXX, VXQ4, VXQ4/A, VXU, VXU/A, VXU1, VXU1/A, VX16, VX16/A, VX8, VX8/A
			3	(3)	-	2167647	-----	BJ, ED7, ED8, ED9, EN, ES, ES1, ET, ETS, ETX, HA, HH, HX, LH, LHC, LHE, LJ, LKE, LX, LXE, LXZ, L1, PX, P1, QA, QAE, QAP, QAPE, QE, QH, QHC, QHE, QNE, QP, QT, QX, QXC, QXE, Q1, SE, SH, SHE, SHEZ, SJ, STP, STQ, SWX, SX, SXE, SXP, S1, VA, VAH1, VAH2, VE, VH, VHE, VX, VXA, VXE, V1, YJ
			3	-	-	-----	3681345	PKX4/A
27	93891-05012-00	SCREW-WASHER, 5X12 .....	(1)	-	(1)	-----	-----	LHQ4, LHQ4/A, LKE/A, LXE4, LXE4/A, LXQ4, LXQ4/A, PKX4, PKX4/A, QE, QE/A, QHQ4, QHQ4/A, QKA4, QKA4/A, QMEO, QMEO/A, QME8, QME8/A, QXC4, QXC4/A, QXE4, QXE4/A, QXQ4, QXQ4/A, SE, SE/A, SHQ4, SHQ4/A, SMEO, SMEO/A, SXE4, SXE4/A, SXQ4, SXQ4/A, VD16, VEB6, VXE4, VXQP, VXQ4, VXQ4/A
			(1)	-	-	2398545	-----	LKE
28	93891-06020-07	SCREW-WASHER, 6X20 .....	(3)	-	(3)	-----	-----	LHQ4, LHQ4/A, LKE/A, LXE4, LXE4/A, LXQ4, LXQ4/A, PKX4, PKX4/A, QE, QE/A, QHQ4, QHQ4/A, QKA4, QKA4/A, QMEO, QMEO/A, QME8, QME8/A, QXC4, QXC4/A, QXE4, QXE4/A, QXQ4, QXQ4/A, SE, SE/A, SHQ4, SHQ4/A, SMEO, SMEO/A, SXE4, SXE4/A, SXQ4, SXQ4/A, VD16, VEB6, VXE4, VXQP, VXQ4, VXQ4/A
			(3)	-	-	2398545	-----	LKE



E-16-1

MUFFLER(2)

2-C 6

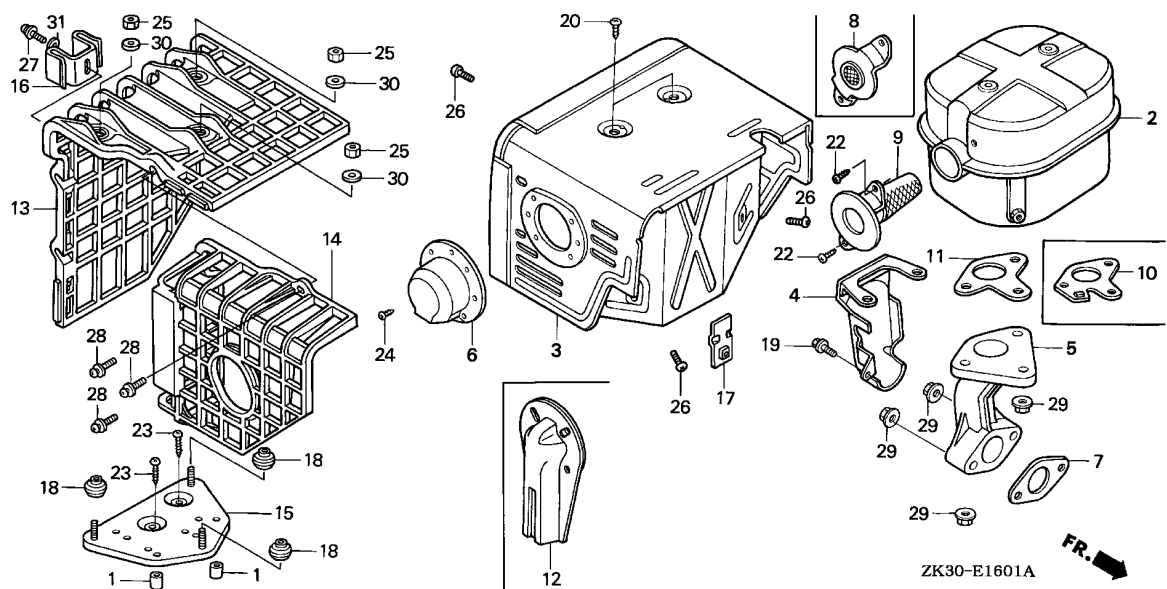

Ref. No.	Part No.	Description	Reqd. QTY			Serial No.	Parts catalogue code
			GX	(1)	(2)		
29	94050-08000	NUT, FLANGE, 8MM .....	5	-	-	-----	BJ,EDK,EDN5,EDN5/A,ED7,ED8,ED8/A,ED9,ED9/A,EN,ES,ES1,ES1/A,ES2,ET ETS,ETX,HA,HAQ,HA2,HA2/A,HH,HX,HX2,HX26,HX26/A,LH,LH/A,LHB1,LHB3 LHB3/A,LHB5,LHC,LHE,LHE/A,LHQ4,LHQ4/A,LJ,LJ/A,LJG,LJG/A,LJS,LJS/A LJS1,LKE,LKE/A,LP,LSX,LT,LT/A,LWD,LX,LX/A,LXE,LXE/A,LXE2,LXE2/A LXE4,LXE4/A,LXE6,LXE8,LXE8/A,LXQ4,LXQ4/A,LXU,LXU/A,LXZ,LX2,LX2/A LX26,LX26/A,PKX4,PX,PX/A,PXE8,PXE8/A,QA,QAC2,QAC2/A,QAE,QAE2 QAE2/A,QAE6,QAE6/A,QAG,QAG/A,QA2,QA2/A,QAP,QAPE,QAP2,QAP2/A,QAQ QA2,QA2/A,QA26,QA26/A,QDW9,QDW9/A,QE,QE/A,QH,QH/A,QHB3,QHB3/A QHB5,QHC,QHE,QHE/A,QHP1,QHP1/A,QHQ4,QHQ4/A,QH2,QKA4,QKA4/A,QL2 QMEO,QMEO/A,QME8,QME8/A,QMH,QMH/A,QMX2,QNE,QNE2,QNE2/A,QNE6,QNE9 QNE9/A,QNR2,QNR2/A,QNR6,QNR6/A,QN18,QP,QP/A,QPE2,QT,QT/A,QTC2 QTC2/A,QWH2,QWH2/A,QX,QX/A,QXC,QXC/A,QXC4,QXC4/A,QXC6,QXC6/A,QXC9 QXC9/A,QXE,QXE/A,QXE2,QXE4,QXE4/A,QXE6,QXE6/A,QXE8,QXE8/A,QXQ4 QXQ4/A,QXU,QXU/A,QX2,SDE,SE,SE/A,SH,SH/A,SHB1,SHB3,SHB3/A,SHE SHEZ,SHQ4,SHQ4/A,SJ,SJ/A,SJG,SJG/A,SKE,SKE/A,SKZ,SKZ/A,SME0 SME0/A,SME2,SMX2,SMX2/A,STP,STP/A,STQ,STQ/A,STR,STR/A,SWX,SWX/A SX,SX/A,SXE,SXE/A,SXE2,SXE4,SXE4/A,SXE8,SXE8/A,SXP,SXQ4,SXQ4/A SXU,SXU/A,VA,VAD2,VAD2/A,VAH1,VAH2,VAW1,VA2,VA2/A,VDE,VDE2,VDE2/A VD16,VE,VEB6,VH,VHE,VH12,VH12/A,VH22,VH22/A,VMX,VWA2,VWE2,VWE2/A VW12,VW12/A,VX,VX/A,VXA,VXE,VXE/A,VXE2,VXE2/A,VXE4,VXE6,VXE8 VXE8/A,VXK,VXQ4,VXQ4/A,VXU,VXU/A,VXU1,VXU1/A,VX16,VX16/A,VX8 VX8/A,YJ
			5	-	-	-----	3681345 PKX4/A
30	94103-05700	WASHER, PLAIN, 5MM .....	(3)	-	(3)	-----	LHQ4,LHQ4/A,LKE/A,LXE4,LXE4/A,LXQ4,LXQ4/A,PKX4,PKX4/A,QE,QE/A QH4,QH4/A,QKA4,QKA4/A,QMEO,QMEO/A,QME8,QME8/A,QXC4,QXC4/A,QXE4 QXE4/A,QXQ4,QXQ4/A,SE,SE/A,SHQ4,SHQ4/A,SME0,SME0/A,SXE4,SXE4/A SXQ4,SXQ4/A,VD16,VEB6,VXE4,VXQP,VXQ4,VXQ4/A
			(3)	-	-	-----	2398545 ----- LKE

2



E-16-1

MUFFLER(2)

2-C 7

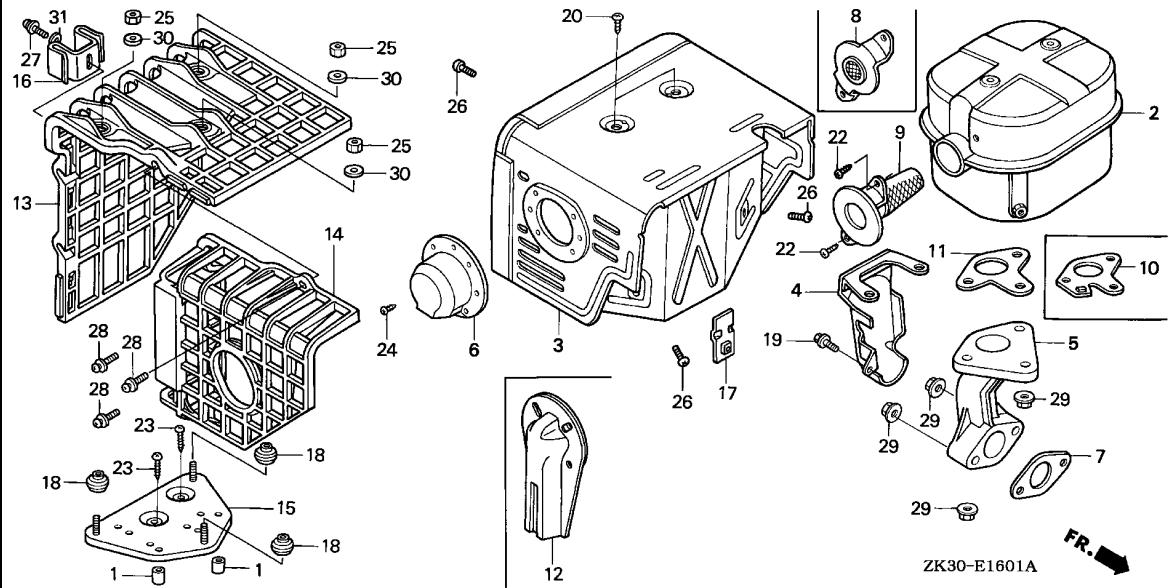

Ref. No.	Part No.	Description	Reqd. QTY			Serial No.	Parts catalogue code
			GX	340K1	(3)		
31	94111-05000	WASHER, SPRING, 5MM	(1)	(2)	(3)	-----	LHQ4,LHQ4/A,LKE/A,LXE4,LXE4/A,LXQ4,LXQ4/A,PKX4,PKX4/A,QE,QE/A,QHQ4,QHQ4/A,QKA4,QKA4/A,QMEO,QMEO/A,QME8,QME8/A,QXC4,QXC4/A,QXE4,QXE4/A,QXQ4,QXQ4/A,SE,SE/A,SHQ4,SHQ4/A,SME0,SME0/A,SXE4,SXE4/A,SXQ4,SXQ4/A,VD16,VEB6,VXE4,VXQP,VXQ4,VXQ4/A
			(1)	-	-	2398545	----- LKE

2

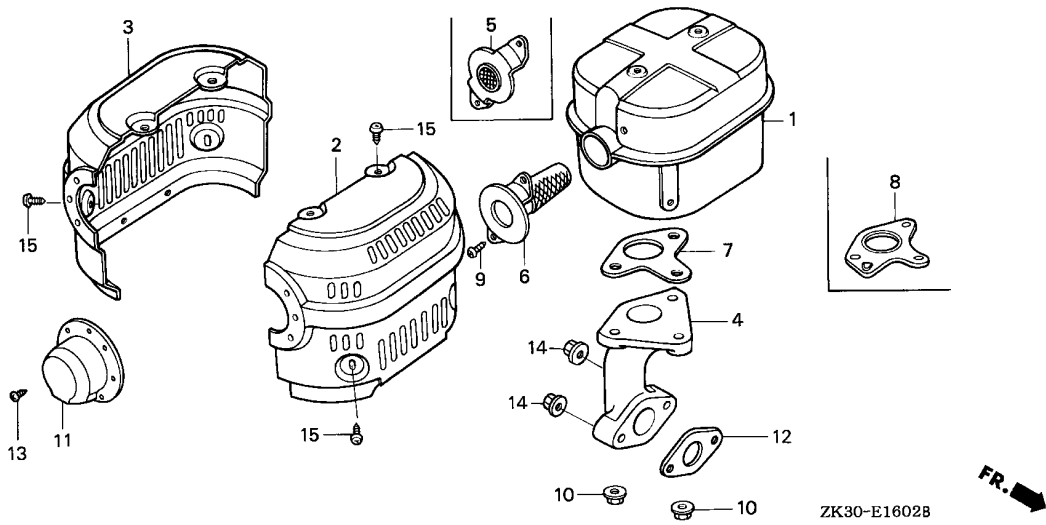

Ref. No.	L.O.N.	(Relative ref. Number) Description	F.R.T.
1	3131C5	MUFFLER, EXHAUST .....	0.2
2	3131D4	PROTECTOR, EXHAUST MUFFLER :RIGHT .....	0.2
3	3131D1	PROTECTOR, EXHAUST MUFFLER :LEFT .....	0.2
4	3131C9	PIPE, EXHAUST .....	0.2
5	3131G5	FLANGE, EXHAUST BAFFLE .....	0.2
6	3131A1	ARRESTER, SPARK .....	0.2
		.INCLUDES: Spark arrester check (8)	
7	3131B4	GASKET, EXHAUST MUFFLER .....	0.2
12	3131B5	GASKET, EXHAUST PIPE .....	0.2

Ref. No.	Part No.	Description	Reqd. QTY			Serial No.	Parts catalogue code
			GX	(1)	(2)		
1	18310-ZE3-003	MUFFLER COMP. ....	1	-	-	LHW,LWD1,LWD1/A,PKT2,PKT2/A,PKT4,PKT4/A,PKX2,PXA2,QAB2,QAB2/A QMT2,QMT2/A	
			-	(1)	-	3681346	PKX4/A
2	18320-ZE3-003 18320-ZE3-G10	PROTECTOR, R. MUFFLER .....	-	(1)	-	2249295	L1,P1,Q1,S1,V1
		(ALUMINIZED)	1	(1)	-		LHW,L1/A,PKT2,PKT2/A,PKT4,PKT4/A,PKX2,PXA2,P1/A,QMT2,QMT2/A,Q1/A S1/A
			1	-	-	3681346	PKX4/A
			-	(1)	-	2249296	L1,P1,Q1,S1,V1
3	18320-ZE3-H00 18325-ZE3-003 18325-ZE3-G10	PROTECTOR, R. MUFFLER .....	1	-	-		LWD1,LWD1/A,QAB2,QAB2/A
		PROTECTOR, L. MUFFLER .....	-	(1)	-	2249295	L1,P1,Q1,S1,V1
		(ALUMINIZED)	1	(1)	-		LHW,L1/A,PKT2,PKT2/A,PKT4,PKT4/A,PKX2,PXA2,P1/A,QMT2,QMT2/A,Q1/A S1/A
			1	-	-	3681346	PKX4/A
			-	(1)	-	2249296	L1,P1,Q1,S1,V1
4	18325-ZE3-H00 18330-ZE2-000	PROTECTOR, L. MUFFLER .....	1	-	-		LWD1,LWD1/A,QAB2,QAB2/A
		PIPE, EX. ....	1	-	-		LHW,LWD1,LWD1/A,PKT2,PKT2/A,PKT4,PKT4/A,PKX2,PXA2,QAB2,QAB2/A QMT2,QMT2/A
			1	-	-	3681346	PKX4/A
			-	(1)	-		
5	18336-ZE3-000	FLANGE COMP., BAFFLE .....	1	-	-		LHW,LWD1,LWD1/A,PKT2,PKT2/A,PKT4,PKT4/A,PKX2,PXA2,QMT2,QMT2/A
			1	-	-	3681346	PKX4/A
			-	(1)	-		
6	18355-ZE3-010	ARRESTER, SPARK .....	1	-	-		QAB2,QAB2/A
			(1)	-	-		PXA2
			-	(1)	-		

2

Ref. No.	Part No.	Description	Reqd. QTY			Serial No.	Parts catalogue code
			(1)	(2)	(3)		
7	18381-ZE2-000	GASKET, MUFFLER .....	-	(1)	-	2127684	L1,P1,Q1,S1,V1
	18381-ZE2-800	GASKET, MUFFLER (NIPPON LEAKLESS)	1	(1)	-		LHW,LWD1,LWD1/A,L1/A,PKT2,PKT2/A,PKT4,PKT4/A,PKX2,PXA2,P1/A,QMT2 QMT2/A,Q1/A,S1/A
			1	-	-	3681346	PKX4/A
			-	(1)	-	2127685	L1,P1,Q1,S1,V1
8	18381-ZE3-820	GASKET, MUFFLER (ARRESTER) ..	-	(1)	-	2178372	L1,P1,Q1,S1,V1
	18381-ZE3-830	.....	(1)	(1)	-		L1/A,PXA2,P1/A,Q1/A,S1/A
			-	(1)	-	2178373	L1,P1,Q1,S1,V1
	18381-ZE2-W10	.....	1	-	-		QAB2,QAB2/A
9	90050-ZE1-000	SCREW, TAPPING, 5X8 .....	2	-	-		LHW,LWD1,LWD1/A,PKT2,PKT2/A,PKT4,PKT4/A,PKX2,PXA2,QAB2,QAB2/A QMT2,QMT2/A
			2	-	-	3681346	PKX4/A
			-	(2)	-		
10	94050-08000	NUT, FLANGE, 8MM .....	3	-	-		LHW,LWD1,LWD1/A,PKT2,PKT2/A,PKT4,PKT4/A,PKX2,PXA2,QAB2,QAB2/A QMT2,QMT2/A
			3	-	-	3681346	PKX4/A
			-	(3)	-		
11	18331-ZE3-810	CAP, MUFFLER .....	1	-	-		LHW,QAB2,QAB2/A
12	18333-ZK6-Y00	GASKET, EX. PIPE .....	1	-	-	3030997	LHW
	18333-ZF6-W01	.....	1	-	-		QAB2,QAB2/A
			1	-	-	3030998	LHW
			1	-	-	3681346	PKX4/A
	18333-ZE3-800	.....	1	-	-		LWD1,LWD1/A,PKT2,PKT2/A,PKT4,PKT4/A,PKX2,PXA2,QMT2,QMT2/A
13	90055-ZE1-000	SCREW, TAPPING, 4X6 .....	3	-	-		LHW,QAB2,QAB2/A
14	94050-08000	NUT, FLANGE, 8MM .....	2	-	-		LHW,LWD1,LWD1/A,PKT4,PKT4/A,PKX2,PXA2,QAB2,QAB2/A
			2	-	-	3681346	PKX4/A
			-	(2)	-		
15	90050-ZE3-H00	SCREW, TAPPING, 5X8 .....	6	-	-		LHW,LWD1,LWD1/A,PKT2,PKT2/A,PKT4,PKT4/A,PKX2,QAB2,QAB2/A,QMT2 QMT2/A
			-	(6)	-		
	90050-ZE1-000	.....	6	-	-		PXA2
			6	-	-	3681346	PKX4/A



E-16-3

MUFFLER(4)

2-C10

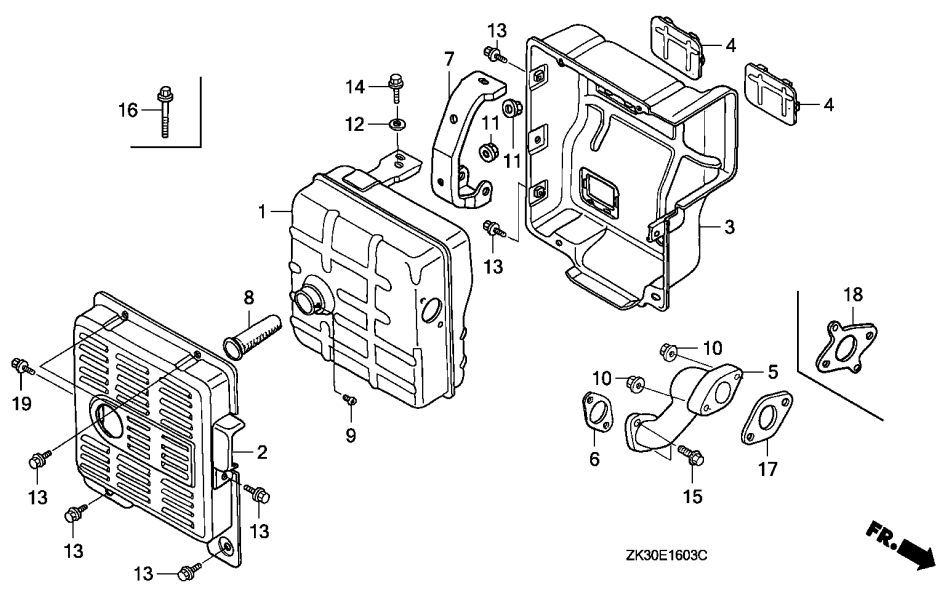

Ref. No.	L.O.N.	(Relative ref. Number) Description	F.R.T.
1	3131C5	MUFFLER, EXHAUST .....	0.2
2	3131D9	PROTECTOR, EXHAUST MUFFLER : OUTER .....	0.1
3	3131D8	PROTECTOR, EXHAUST MUFFLER : INNER .....	0.2
4	3131G6	SEAL, MUFFLER PROTECTOR .....	0.2
5	3131C9	PIPE, EXHAUST .....	0.2
6	3131B5	GASKET, EXHAUST PIPE .....	0.2
8	3131A1	ARRESTER, SPARK .....	0.2
		.INCLUDES: Spark arrester check	

Ref. No.	Part No.	Description	Reqd. QTY			Serial No.	Parts catalogue code
			GX	340K1			
			(1)	(2)	(3)		
1	18310-ZD1-E31	MUFFLER COMP. ....	1	-	-	-----	EDS,EDS1,EDS1/A,EDS2,EDS2/A,EDS3,EDS4,EDS6,EDS6/A,EDT,EDT/A,EDT1 EDT1/A,EDT2,EDT3,EDT6,EDT6/A,EMT,EMT/A,ES3,ES3/A,ES4,ES4/A,VAA VAAE,VMQ,VMT,VMT/A
	18310-ZE2-U90	MUFFLER COMP. (DENYO) .....	1	-	-	-----	2374605 Ede6
	18310-ZE2-V60	MUFFLER COMP. (TSURUMI) .....	1	-	-	-----	EDE2,EDE2/A,EDN,EDN2,EDN2/A
			1	-	-	-----	2374606 ED6/A,ENT,ENT/A,ENT2,EN6,EN6/A,VS2,VS3,VS4,VS5,VS6,VS7,VTE2
2	18320-ZC2-000	PROTECTOR, MUFFLER OUTER ....	1	-	-	-----	Ede6
3	18325-ZB4-000	PROTECTOR, MUFFLER INNER ....	1	-	-	-----	EDE2,EDE2/A,EDN,EDN2,EDN2/A,EDS,EDS1,EDS1/A,EDS2,EDS2/A,EDS3,EDS4 EDS6,EDS6/A,EDT,EDT/A,EDT1,EDT1/A,EDT2,EDT3,EDT6,EDT6/A,ED6,ED6/A EMT,EMT/A,ENT,ENT/A,EN6,EN6/A,ES3,ES3/A,ES4,ES4/A,VAA,VAAE,VMQ VMT,VMT/A,VS2,VS3,VS4,VS5,VS6,VS7,VTE2
4	18329-ZB4-000	SEAL, MUFFLER PROTECTOR .....	2	-	-	-----	EDE2,EDE2/A,EDN,EDN2,EDN2/A,EDS,EDS1,EDS1/A,EDS2,EDS2/A,EDS3,EDS4 EDS6,EDS6/A,EDT,EDT/A,EDT1,EDT1/A,EDT2,EDT3,EDT6,EDT6/A,ED6,ED6/A EMT,EMT/A,ENT,ENT/A,ENT2,EN6,EN6/A,ES3,ES3/A,ES4,ES4/A,VAA,VAAE VMQ,VMT,VMT/A,VS2,VS3,VS4,VS5,VS6,VS7,VTE2
5	18330-ZE3-700	PIPE, EX. ....	1	-	-	-----	EDE2,EDE2/A,EDN,EDN2,EDN2/A,EDS,EDS1,EDS1/A,EDS2,EDS2/A,EDS3,EDS4 EDS6,EDS6/A,EDT,EDT/A,EDT1,EDT1/A,EDT2,EDT3,EDT6,EDT6/A,ED6,ED6/A ENT,ENT/A,ENT2,EN6,EN6/A,ES3,ES3/A,ES4,ES4/A,VAA,VAAE,VMQ,VS2,VS3 VS4,VS5,VS6,VS7,VTE2
	18330-ZE3-710	.....	1	-	-	-----	EMT,EMT/A,VMT,VMT/A
6	18333-ZB4-800	GASKET, EX. PIPE .....	1	-	-	-----	EDE2,EDE2/A,EDN,EDN2,EDN2/A,EDS,EDS1,EDS1/A,EDS2,EDS2/A,EDS3,EDS4 EDS6,EDS6/A,EDT,EDT/A,EDT1,EDT1/A,EDT2,EDT3,EDT6,EDT6/A,ED6,ED6/A EMT,EMT/A,ENT,ENT/A,ENT2,EN6,EN6/A,ES3,ES3/A,ES4,ES4/A,VAA,VAAE VMQ,VMT,VMT/A,VS2,VS3,VS4,VS5,VS6,VS7,VTE2

2

Ref. No.	Part No.	Description	Reqd. QTY			Serial No.	Parts catalogue code
			(1)	(2)	(3)		
7	18338-ZE2-V60	STAY A, MUFFLER (TSURUMI) ...	1	-	-	-----	ED6,ED6/A,ENT,ENT/A,VTE2
8	18355-ZB4-630	ARRESTER, SPARK .....	1	-	-	-----	EDE2,EDE2/A,EDN,EDN2,EDN2/A,EDS,EDS1,EDS1/A,EDS2,EDS2/A,EDS3,EDS4,EDS6,EDS6/A,EDT,EDT/A,EDT1,EDT1/A,EDT2,EDT3,EDT6,EDT6/A,ED6,ED6/A,ENT,ENT/A,ENT2,EN6,EN6/A,ES4,ES4/A,VAA,VA AE,VTE2
9	90002-ZE2-U91	SCREW, TAPPING, 4X8 .....	1	-	-	-----	2589845 ES3
10	94050-08000	NUT, FLANGE, 8MM .....	2	-	-	-----	EDE2,EDE2/A,EDN,EDN2,EDN2/A,EDS,EDS1,EDS1/A,EDS2,EDS2/A,EDS3,EDS4,EDS6,EDS6/A,EDT,EDT/A,EDT1,EDT1/A,EDT2,EDT3,EDT6,EDT6/A,ED6,ED6/A,ENT,ENT/A,ENT2,EN6,EN6/A,ES3,ES4,ES4/A,VAA,VA AE,VTE2
11	94050-08000	NUT, FLANGE, 8MM .....	2	-	-	-----	EDE2,EDE2/A,EDN,EDN2,EDN2/A,EDS,EDS1,EDS1/A,EDS2,EDS2/A,EDS3,EDS4,EDS6,EDS6/A,EDT,EDT/A,EDT1,EDT1/A,EDT2,EDT3,EDT6,EDT6/A,ED6,ED6/A,EMT,EMT/A,ENT,ENT/A,ENT2,EN6,EN6/A,ES3,ES3/A,ES4,ES4/A,VAA,VA AE,VMQ,VMT,VMT/A,VS2,VS3,VS4,VS5,VS6,VS7,VTE2
12	94103-08000	WASHER, PLAIN, 8MM .....	1	-	-	-----	ED6,ED6/A,ENT,ENT/A,VTE2
13	95701-06010-00	BOLT, FLANGE, 6X10 .....	7	-	-	-----	VAA,VA AE
	95701-06012-00	BOLT, FLANGE, 6X12 .....	7	-	-	-----	EDE2,EDE2/A,EDN,EDN2,EDN2/A,EDT,EDT/A,EDT1,EDT6,EDT6/A,ED6,ED6/A,EMT,EMT/A,ENT,ENT/A,EN6,EN6/A,VAA,VA AE,VMQ,VMT,VMT/A,VTE2
			7	-	-	-----	4088023 EDT1/A
			7	-	-	-----	EDS,EDS1,EDS1/A,EDS2,EDS2/A,EDS3,EDS4,EDS6,EDS6/A,ES3,ES3/A,ES4,ES4/A,VS3,VS4,VS5,VS6
			2	-	-	-----	VS2,VS7
			7	-	-	-----	EDT3
14	95701-08016-08	BOLT, FLANGE, 8X16 .....	7	-	-	-----	4088024 EDT1/A
15	95701-08020-00	BOLT, FLANGE, 8X20 .....	2	-	-	-----	VAA,VA AE
16	95701-08070-00	BOLT, FLANGE, 8X70 .....	1	-	-	-----	EDE2,EDE2/A,EDN,EDN2,EDN2/A,EDS,EDS1,EDS1/A,EDS2,EDS2/A,EDS3,EDS4,EDS6,EDS6/A,EDT,EDT/A,EDT1,EDT1/A,EDT2,EDT3,EDT6,EDT6/A,ED6,ED6/A,EMT,EMT/A,ENT,ENT/A,ENT2,EN6,EN6/A,ES3,ES3/A,ES4,ES4/A,VAA,VA AE,VMQ,VMT,VMT/A,VS2,VS3,VS4,VS5,VS6,VS7,VTE2
17	18333-ZE3-800	GASKET, EX. PIPE .....	1	-	-	-----	ED6/A,EN6,EN6/A,VTE2
			1	-	-	-----	2374606 ED6
18	18333-ZF6-W01	GASKET, EX. PIPE .....	1	-	-	-----	EDE2,EDE2/A,EDN,EDN2,EDN2/A,EDS,EDS1,EDS2,EDS2/A,EDS3,EDS6,EDS6/A,EDT,EDT/A,EDT1,EDT2,EDT6,EDT6/A,ED6,ED6/A,EMT,ENT,ENT/A,ENT2,EN6,EN6/A,ES3,ES4,VAA,VA AE,VMT,VTE2
19	95701-06010-00	BOLT, FLANGE, 6X10 .....	1	-	-	-----	4044212 EDS1/A,EDS4,EDT1/A,EMT/A,ES3/A,ES4/A,VMQ,VMT/A,VS3,VS4,VS5,VS6
	95701-06012-00	BOLT, FLANGE, 6X12 .....	1	-	-	-----	EDT3,VS2,VS7
			1	-	-	-----	4044213 EDS1/A,EDS4,EDT1/A,EMT/A,ES3/A,ES4/A,VMQ,VMT/A,VS3,VS4,VS5,VS6
			1	-	-	-----	EDE2,EDE2/A,EDN,EDN2,EDN2/A,EDT,EDT/A,EDT1,EDT1/A,EDT6,EDT6/A,ED6,ED6/A,EMT,EMT/A,ENT,ENT/A,EN6,EN6/A,VAA,VA AE,VMQ,VMT,VMT/A,VTE2
			1	-	-	-----	EDS,EDS1,EDS2,EDS2/A,EDS3,EDS4,EDS6,EDS6/A,ES3,ES3/A,ES4,ES4/A,VS3,VS4,VS5,VS6
			1	-	-	-----	4088023 EDS1/A
			2	-	-	-----	VS2,VS7
			1	-	-	-----	EDT3
			1	-	-	-----	4088024 EDS1/A



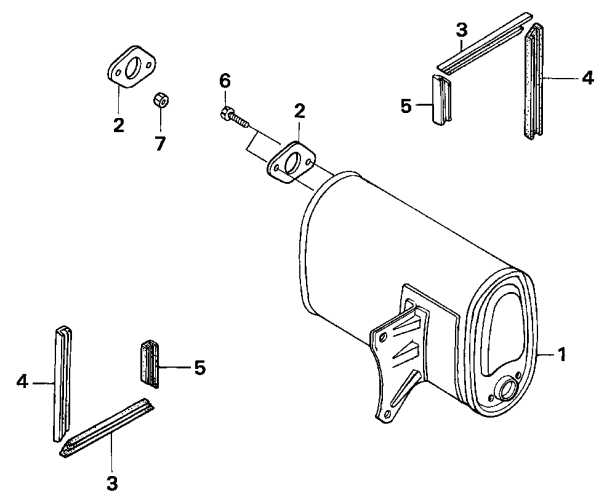

ZK30-E1604B

Ref. No.	L.O.N.	(Relative ref. Number) Description	F.R.T.
1	3131C5	MUFFLER, EXHAUST .....	0.2
2	3131B5	GASKET, EXHAUST PIPE .....	0.2
3	3131G7	(4,5) SEAL, MUFFLER DUCT .....	0.2



Ref. No.	Part No.	Description	Reqd. QTY			Serial No.	Parts catalogue code
			GX	340K1			
			(1)	(2)	(3)		
1	18310-ZB8-003	MUFFLER COMP. ....	1	-	-	-----	EDS5,STJ,STJ/A
2	18333-ZB7-800	GASKET, EX. PIPE .....	2	-	-	-----	EDS5
	18333-ZE3-000	.....	1	-	-	2127684	STJ
	18333-ZE3-800	.....	1	-	-	-----	STJ/A
3	18412-ZB7-000	SEAL, MUFFLER DUCT (A) .....	1	-	-	2127685	STJ
4	18413-ZB7-000	SEAL, MUFFLER DUCT (B) .....	2	-	-	-----	EDS5
5	18414-ZB7-000	SEAL, MUFFLER DUCT (C) .....	2	-	-	-----	EDS5
6	92101-08028-0A	BOLT, HEX., 8X28 .....	2	-	-	-----	EDS5
7	94001-08000-0S	NUT, HEX., 8MM .....	2	-	-	-----	EDS5

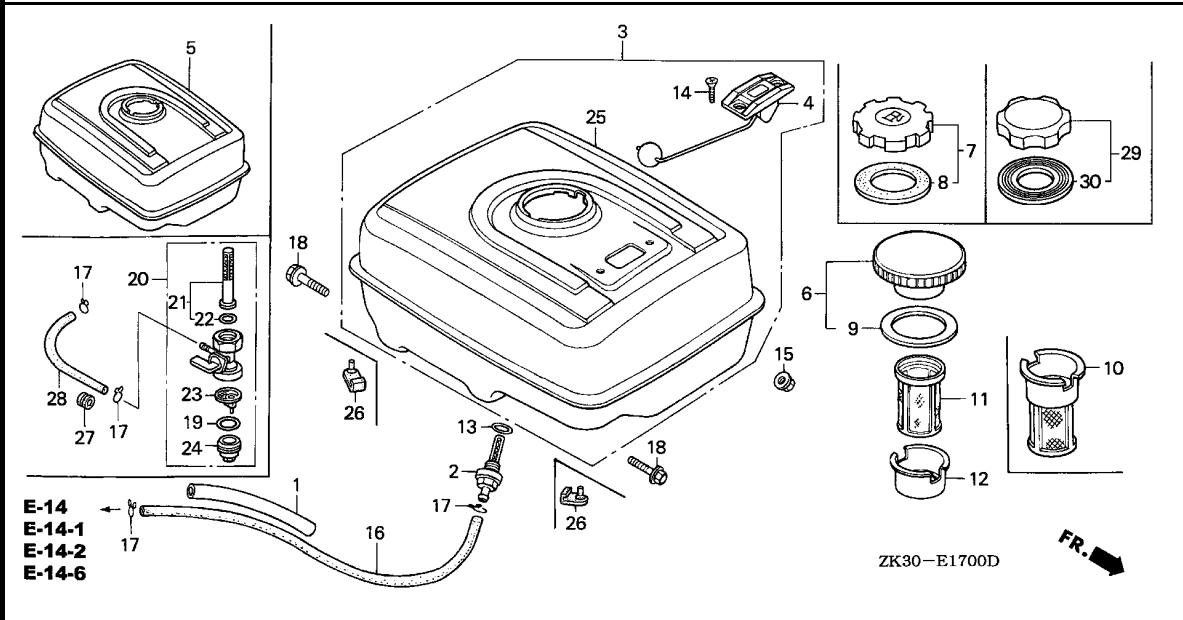

Ref. No.	L.O.N.	(Relative ref. Number) Description	F.R.T.
2	(13)	JOINT, FUEL STRAINER .....	0.2
3	(5,25)	TANK, FUEL .....	0.2
4	6171A1	METER/GAUGE UNIT, FUEL .....	0.1
11	(10)	FILTER, FUEL .....	0.1
16	3101F1	TUBE, FUEL TANK .....	0.2
20	3101A3	COCK, FUEL .....	0.2
21	3101D5	SCREEN, FUEL STRAINER .....	0.2
23	(19,24)	FILTER, FUEL TANK CUP .....	0.2
28	3101F2	TUBE, FUEL COCK .....	0.2

Ref. No.	Part No.	Description	Reqd. QTY			Serial No.	Parts catalogue code
			GX 340K1	(1)	(2)		
1	16854-ZE1-000	RUBBER, SUPPORTER (107MM) ...	1	-	-	2045717	BJ, HA, HH, HX, LH, LHC, LHE, LJ, LKE, LX, LXE, LXZ, PX, QA, QAE, QAP, QAPE, QE, QH, QHC, QHE, QNE, QT, QX, QXB, QXC, QXE, QXEB, SE, SH, SHE, SHEZ, SJ, STP, STQ, SWX, SX, SXB, SXE, SXEB, SXP, VA, VE, VH, VHE, VX, VXB, VXE, VXEB, YJ
	16854-ZH8-000	.....	1	(1)	-	2167646	L1, P1, Q1, S1, V1 EDK, ED7, ED8, ED8/A, ED9, ED9/A, ES, ES1, ES1/A, ES2, HAQ, HA2, HA2/A, HX2, HX26, HX26/A, LH/A, LHB1, LHB3, LHB3/A, LHB5, LHE/A, LHQ4, LHQ4/A, LHW, LJ/A, LJG, LJG/A, LJS, LJS/A, LJS1, LKE/A, LP, LSX, LT, LT/A, LWD, LWD1, LWD1/A, LX/A, LXE/A, LXE2, LXE2/A, LXE4, LXE4/A, LXE6, LXE8, LXE8/A, LXQ4, LXQ4/A, LXU, LXU/A, LX2, LX2/A, LX26, LX26/A, L1/A, PKT2, PKT2/A, PKT4, PKT4/A, PKX2, PKX4, PKX4/A, PX/A, PXA2, PXE8, PXE8/A, P1/A, QAB2, QAB2/A, QAC2, QAC2/A, QAE2, QAE2/A, QAE6, QAE6/A, QAG, QAG/A, QAH2, QAH2/A, QAP2, QAP2/A, QAQ, QA2, QA2/A, QA26, QA26/A, QDW9, QDW9/A, QE/A, QH/A, QHB3, QHB3/A, QHB5, QHE/A, QHP1, QHP1/A, QHQ4, QHQ4/A, QH2, QKA4, QKA4/A, QL2, QMED, QMED/A, QME8, QME8/A, QMH, QMH/A, QMT2, QMT2/A, QMX2, QNE2, QNE2/A, QNE6, QNE9, QNE9/A, QNR2, QNR2/A, QNR6, QNR6/A, QN18, QP, QP/A, QPE2, QT/A, QTC2, QTC2/A, QWH2, QWH2/A, QX/A, QXB/A, QXB7, QXB7/A, QXC/A, QXC4, QXC4/A, QXC6, QXC6/A, QXC9, QXC9/A, QXE/A, QXE2, QXE4, QXE4/A, QXE6, QXE6/A, QXE8, QXE8/A, QXQ4, QXQ4/A, QXU, QXU/A, QX2, Q1/A, SDE, SE/A, SH/A, SHB1, SHB3, SHB3/A, SHQ4, SHQ4/A, SJ/A, SJG, SJG/A, SKE, SKE/A, SKZ, SKZ/A, SMEO, SMEO/A, SME2, SMX2, SMX2/A, STJ, STJ/A, STP/A, STQ/A, SWX/A, SX/A, SXB/A, SXB7, SXB7/A, SXE/A, SXEB/A, SXE2, SXE4, SXE4/A, SXE8, SXE8/A, SXQ4, SXQ4/A, SXU, SXU/A, S1/A, VAW1, VA2, VA2/A, VC2, VC2/A, VDE, VDE2, VDE2/A, VD16, VEB6, VMX, VNG1, VNG2, VSH7, VMC, VME, VME2, VME2/A, VW12, VW12/A, VX/A, VXB/A, VXB2, VXB7, VXB7/A, VXE/A, VXEB/A, VXE2, VXE2/A, VXE4, VXE6, VXE7, VXE7/A, VXE8, VXE8/A, VXG, VXK, VXQ4, VXQ4/A, VXU, VXU/A, VXU1, VXU1/A, VX16, VX16/A, VX8, VX8/A
			1	-	-	2045718	BJ, HA, HH, HX, LH, LHC, LHE, LJ, LKE, LX, LXE, LXZ, PX, QA, QAE, QAP, QAPE, QE, QH, QHC, QHE, QNE, QT, QX, QXB, QXC, QXE, QXEB, SE, SH, SHE, SHEZ, SJ, STP, STQ, SWX, SX, SXB, SXE, SXEB, SXP, VA, VE, VH, VHE, VX, VXB, VXE, VXEB, YJ
			-	(1)	-	2167647	L1, P1, Q1, S1, V1



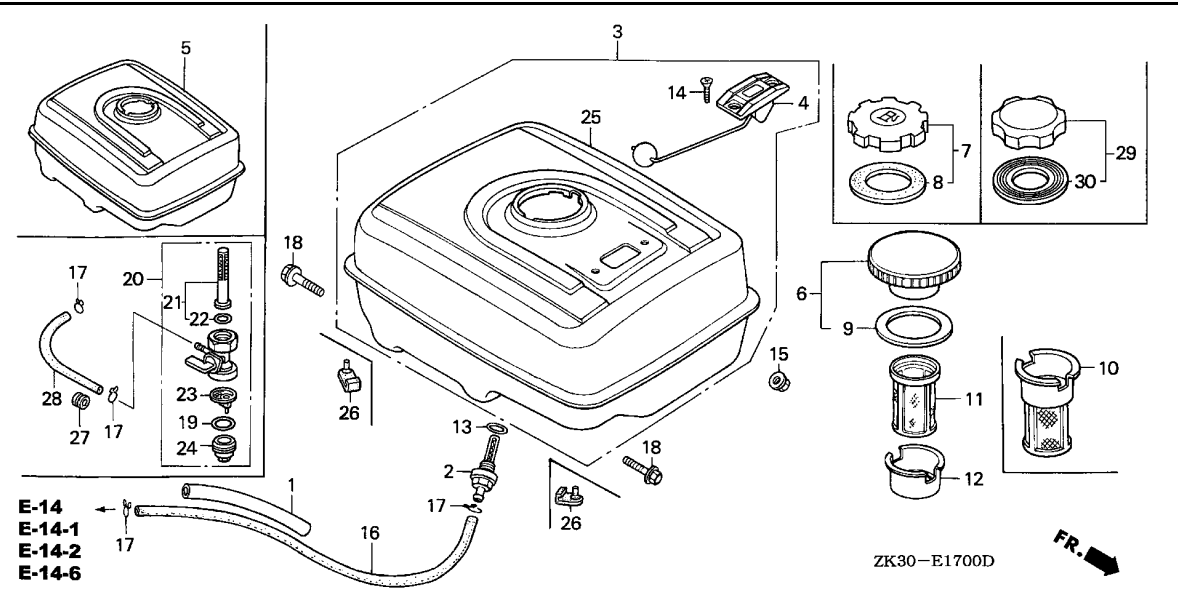

Ref. No.	Part No.	Description	Reqd. QTY			Serial No.	Parts catalogue code
			GX	(1)	(2)		
2	16955-ZE1-000	JOINT, FUEL TANK .....	1	-	-	-----	BJ,EDK,ED7,ED8,ED8/A,ED9,ED9/A,ES,ES1,ES1/A,ES2,HA,HAQ,HA2,HA2/A,HH,HX,HX2,HX26,A,LH,LH/A,LHB1,LHB3,LHB3/A,LHB5,LHC,LHE,LHE/A,LHQ4,LHQ4/A,LHW,LJ,LJ/A,LJG,LJG/A,LJS,LJS/A,LJS1,LKE,LKE/A,LP,LSX,LT,LT/A,LWD,LWD1,LWD1/A,LX,LX/A,LXE,LXE/A,LXE2,LXE2/A,LXE4,LXE4/A,LXE6,LXE8,LXE8/A,LXQ4,LXQ4/A,LXU,LXU/A,LXZ,LX2,LX2/A,LX26,LX26/A,PKT2,PKT2/A,PKT4,PKT4/A,PKX2,PKX4,PKX4/A,PX,PX/A,PXA2,PXE8,PXE8/A,QA,QAB2,QAB2/A,QAE,QAE2,QAE2/A,QAE6,QAE6/A,QAG,QAG/A,QA2,QA2/A,QAP,QAPE,QAP2,QAP2/A,QAQ,QA2,QA2/A,QA26,QA26/A,QDW9,QDW9/A,QE,QE/A,QH,QH/A,QHB3,QHB3/A,QHB5,QHC,QHE,QHE/A,QHP1,QHP1/A,QHQ4,QHQ4/A,QH2,QKA4,QKA4/A,QL2,QMED,QMED/A,QME8,QME8/A,QMH,QMH/A,QMT2,QMT2/A,QMX2,QNE,QNE2,QNE2/A,QNE6,QNE9,QNE9/A,QNR2,QNR2/A,QNR6,QNR6/A,QN18,QP,QP/A,QPE2,QT,QT/A,QTC2,QTC2/A,QWH2,QWH2/A,QX,QX/A,QXB,QXB/A,QXB7,QXB7/A,QXC,QXC/A,QXC4,QXC4/A,QXC6,QXC6/A,QXC9,QXC9/A,QXE,QXE/A,QXEB,QXE2,QXE4,QXE4/A,QXE6,QXE6/A,QXE8,QXE8/A,QXQ4,QXQ4/A,QXU,QXU/A,QX2,SDE,SE,SE/A,SH,SH/A,SHB1,SHB3,SHB3/A,SHE,SHEZ,SHQ4,SHQ4/A,SJ,SJ/A,SJG,SJG/A,SKE,SKE/A,SKZ,SKZ/A,SME0,SME0/A,SME2,SMX2,SMX2/A,STJ,STJ/A,STP,STP/A,STQ,STQ/A,SWX,SWX/A,SX,SX/A,SXB,SXB/A,SXB7,SXB7/A,SXE,SXE/A,SXEB,SXEB/A,SXE2,SXE4,SXE4/A,SXE8,SXE8/A,SXP,SXQ4,SXQ4/A,SXU,SXU/A,VA,VA2,VA2/A,VD16,VE,VEB6,VH,VHE,VMX,VX,VX/A,VXB,VXB/A,VXB2,VXB7,VXB7/A,VXE,VXE/A,VXEB,VXEB/A,VXE2,VXE2/A,VXE4,VXE6,VXE7,VXE7/A,VXE8,VXE8/A,VXG,VXK,VXQ4,VXQ4/A,VXU,VXU/A,VXU1,VXU1/A,VX16,VX16/A,VX8,VX8/A,YJ
3	17500-ZE3-811ZA	TANK ASSY., FUEL (GAUGE) *NH31*.....MCKINLEY WHITE	1	(1)	-	-----	LJG,LJS,L1,P1,Q1,SDE,SJG,SKE,STJ,S1,VXG,V1
	17500-ZE3-811ZB	*R165*.....JOLLY RED	1	(1)	-	3792141	LJG/A,LJS/A,LJS1,LWD,L1/A,P1/A,Q1/A,SJG/A,SKE/A,SKZ/A,STJ/A,S1/A
	17500-ZE3-811ZF	*R280*.....POWER RED	1	-	-	2599031	SKZ
			1	-	-	-----	LWD1
			1	-	-	3770606	LWD1/A





Ref. No.	Part No.	Description	Reqd. QTY			Serial No.	Parts catalogue code
			(1)	(2)	(3)		
(3)	17500-ZE3-812ZA	TANK ASSY., FUEL (GAUGE)					
		*NH31*.....MCKINLEY WHITE	1	(1)	-	3792142 3983330	LJG/A,LJS/A,LJS1,LWD,L1/A,P1/A,Q1/A,SJG/A,SKE/A,SKZ/A,STJ/A,S1/A
	17500-ZE3-812ZF	*R280*.....POWER RED	1	-	-	3770607 3983330	LWD1/A
	17500-ZE3-813ZA	*NH31*.....MCKINLEY WHITE	1	(1)	-	3983331	LJG/A,LJS/A,LJS1,LWD,L1/A,P1/A,Q1/A,SJG/A,SKE/A,SKZ/A,STJ/A,S1/A
	17500-ZE3-813ZF	*R280*.....POWER RED	1	-	-	3983331	LWD1/A
4	17505-ZE2-013	GAUGE ASSY., FUEL	1	-	-		LJG,LJG/A,LJS,LJS/A,LJS1,LWD,LWD1,LWD1/A,SDE,SJG,SJG/A,SKE,SKE/A,SKZ/A,STJ,STJ/A,VXG
			1	-	-	2599031	SKZ
			-	(1)	-		
5	17510-ZE3-010ZA	TANK COMP., FUEL					
		*NH31*.....MCKINLEY WHITE	1	(1)	-		BJ,ED7,ED8,ED9,ES,ES1,HA,HAQ,HA2,HH,HX,HX2,HX26,LH,LHB1,LHB3,LHC,LHE,LHQ4,LHW,LJ,LKE,LP,LSX,LT,LX,LXE,LXE2,LXE4,LXE6,LXE8,LXQ4,LXU,LXZ,LX2,LX26,L1,PKT2,PKT4,PKX4,PX,PXE8,P1,QA,QAB2,QAE,QAE2,QAE6,QAG,QA2,QAP,QAPE,QAQ,QA2,QA26,QE,QH,QHB3,QHC,QHE,QHP1,QHQ4,QH2,QKA4,QME0,QME8,QMH,QMT2,QMX2,QNE,QNE2,QNE6,QNE9,QNR2,QNR6,QN18,QP,QT,QTC2,QX,QXB,QXB7,QXC,QXC4,QXC6,QXC9,QXE,QXE6,QXE2,QXE4,QXE6,QXE8,QXQ4,QXU,Q1,SE,SH,SHB1,SHB3,SHE,SHEZ,SHQ4,SJ,SMEO,SME2,SMX2,STP,STQ,SWX,SX,SXB,SXB7,SXE,SXEB,SXE2,SXE4,SXE8,SXP,XXQ4,XXU,S1,VA,VA2,VDE,VD16,VE,VEB6,VH,VHE,VMX,VX,VXB,VXB2,VXB7,VA,STP/VXEB,VXE2,VXE4,VXE6,VXE7,VXE8,VXQ4,VXU,VXU1,VX16,VX8,V1,YJ
			1	(1)	-	3792141	ED8/A,ED9/A,ES1/A,HA2/A,HX26/A,LH/A,LHB3/A,LHB5,LHE/A,LHQ4/A,LJ/A,LKE/A,LT/A,LX/A,LXE/A,LXE2/A,LXE4/A,LXE8/A,LXQ4/A,LXU/A,LX2/A,LX26/A,L1/A,PKT2/A,PKT4/A,PKX2,PKX4/A,PX/A,PXE8/A,P1/A,QAB2/A,QAE2/A,QAE6/A,QAG/A,QA2/A,QAP2/A,QA2/A,QA26/A,QA2/A,QH/A,QHB3/A,QHB5,QHE/A,QHP1/A,QHQ4/A,QKA4/A,QME0/A,QME8/A,QMH/A,QMT2/A,QNE2/A,QNE9/A,QNR2/A,QNR6/A,QP/A,QT/A,QTC2/A,QWH2/A,QX/A,QXB/A,QXB7/A,QXC/A,QXC4/A,QXC6/A,QXC9/A,QXE/A,QXE4/A,QXE6/A,QXE8/A,QXQ4/A,QXU/A,Q1/A,SE/A,SH/A,SHB3/A,SHQ4/A,SJ/A,SMEO/A,SMX2/A,STP/A,STQ/A,SWX/A,SX/A,SXB/A,SXB7/A,SXE/A,SXEB/A,SXE4/A,SXE8/A,XXQ4/A,XXU/A,S1/A,VA2/A,VX/A,VXB/A,VXB7/A,VXE/A,VXEB/A,VXE2/A,VXE7/A,VXE8/A,VXQ4/A,VXU/A,VXU1/A,VX16/A,VX8/A
			1	-	-	2599030	SKZ
	17510-ZE3-010ZB	*NH1*.....BLACK	1	-	-		HAQ,QAE2,QAP2,QAQ,QDW9,QKA4,QL2,QME0,QMT2,QMX2,QNE9,QNR2,QPE2,QWH2,QXQ4,QX2,SMEO,SME2,SMX2
			1	-	-	3792141	PKT2/A,PX/A,QAE2/A,QAP2/A,QDW9/A,QKA4/A,QME0/A,QMT2/A,QNE9/A,QNR2/A,QWH2/A,QX/A,QXC9/A,QXQ4/A,SMEO/A,SMX2/A
	17510-ZE3-010ZD	*T34*.....SIMPSON BLUE	1	-	-		QA2
			1	-	-	3792141	QA2/A
	17510-ZE3-010ZE	*NH105*...MAT BLACK (#15-#20)	1	-	-		VXB7,VXE2,VXE7
			1	-	-	3792141	VXB7/A,VXE/A,VXE2/A,VXE7/A
	17510-ZE3-010ZF	*Y131*.....LIGHTNING YELLOW	1	-	-		ES1
			1	-	-	3792141	ES1/A
	17510-ZE3-010ZG	*T77*.....SEC WINE RED	1	-	-		ES1
			1	-	-	3792141	ES1/A
	17510-ZE3-010ZH	*R280*.....POWER RED	1	-	-		3792141
			1	-	-	3792141	ES1/A
	17510-ZE3-020ZA	*NH31*.....MCKINLEY WHITE	1	(1)	-	3792142 3980511	ED8/A,ED9/A,ES1/A,HA2/A,HX26/A,LH/A,LHB3/A,LHB5,LHE/A,LHQ4/A,LJ/A,LKE/A,LT/A,LX/A,LXE/A,LXE2/A,LXE4/A,LXE8/A,LXQ4/A,LXU/A,LX2/A,LX26/A,L1/A,PKT2/A,PKT4/A,PKX2,PKX4/A,PX/A,PXE8/A,P1/A,QAB2/A,QAE2/A,QAE6/A,QAG/A,QA2/A,QAP2/A,QA2/A,QA26/A,QA2/A,QH/A,QHB3/A,QHB5,QHE/A,QHP1/A,QHQ4/A,QKA4/A,QME0/A,QME8/A,QMH/A,QMT2/A,QNE2/A,QNE9/A,QNR2/A,QNR6/A,QP/A,QT/A,QTC2/A,QWH2/A,QX/A,QXB/A,QXB7/A,QXC/A,QXC4/A,QXC6/A,QXC9/A,QXE/A,QXE4/A,QXE6/A,QXE8/A,QXQ4/A,QXU/A,Q1/A,SE/A,SH/A,SHB3/A,SHQ4/A,SJ/A,SMEO/A,SMX2/A,STP/A,STQ/A,SWX/A,SX/A,SXB/A,SXB7/A,SXE/A,SXEB/A,SXE4/A,SXE8/A,XXQ4/A,XXU/A,S1/A,VA2/A,VX/A,VXB/A,VXB7/A,VXE/A,VXEB/A,VXE2/A,VXE7/A,VXE8/A,VXQ4/A,VXU/A,VXU1/A,VX16/A,VX8/A
			1	-	-	3980511	PXA2



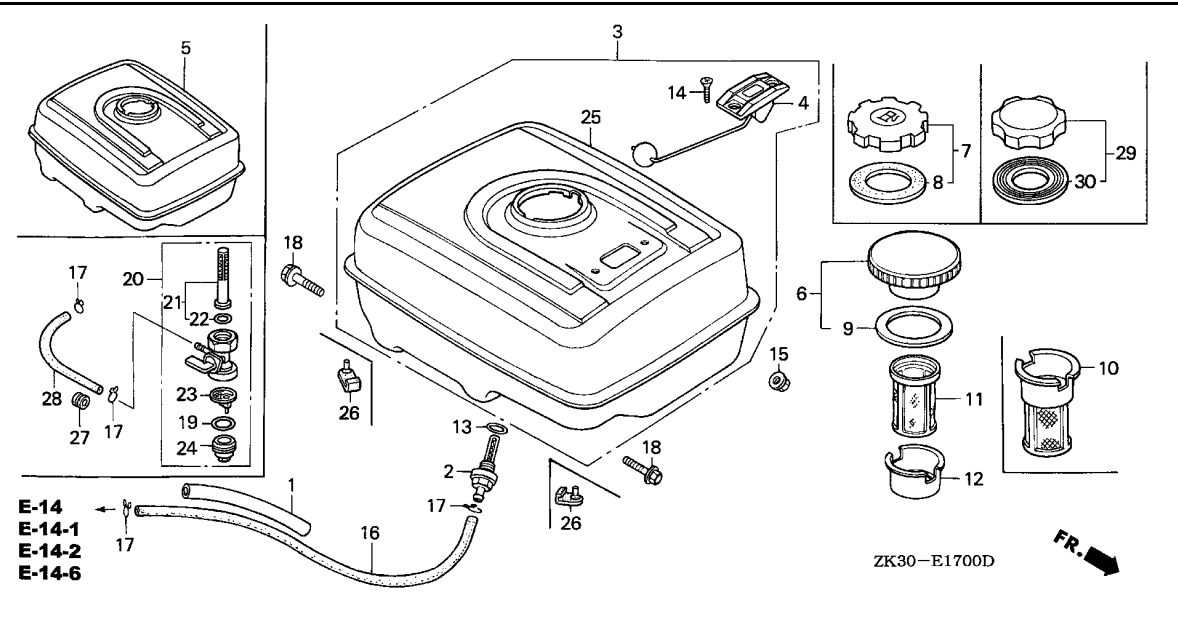

Ref. No.	Part No.	Description	Reqd. QTY			Serial No.	Parts catalogue code
			GX	(1)	(2)		
(5)	17510-ZE3-020ZB	TANK COMP., FUEL					
		*NH1*.....BLACK	1	-	-	3792142 3980511	PKT2/A, PX/A, QAE2/A, QAP2/A, QDW9/A, QKA4/A, QMEO/A, QMT2/A, QNE9/A, QNR2/A, QWH2/A, QX/A, QXC9/A, QXQ4/A, SMEO/A, SMX2/A
	17510-ZE3-020ZD	*T34*.....SIMPSON BLUE	1	-	-	3792142 3980511	QA2/A
	17510-ZE3-020ZE	*NH105*...MAT BLACK (#15-#20)	1	-	-	3792142 3980511	VXB7/A, VXE/A, VXE2/A, VXE7/A
	17510-ZE3-020ZF	*Y131*.....LIGHTNING YELLOW	1	-	-	3792142 3980511	ES1/A
	17510-ZE3-020ZG	*T77*.....SEC WINE RED	1	-	-	3792142 3980511	ES1/A
	17510-ZE3-020ZH	*R280*.....POWER RED	1	-	-	3792142 3980511	ES1/A
	17510-ZE3-800ZA	*NH1*.....BLACK	1	-	-	3980512	PKT2/A, PX/A, QAE2/A, QAP2/A, QDW9/A, QKA4/A, QMEO/A, QMT2/A, QNE9/A, QNR2/A, QWH2/A, QX/A, QXC9/A, QXQ4/A, SMEO/A, SMX2/A
	17510-ZE3-800ZB	*NH105*...MAT BLACK (#15-#20)	1	-	-	3980512	VXB7/A, VXE/A, VXE2/A, VXE7/A
	17510-ZE3-800ZC	*NH31*.....MCKINLEY WHITE	1	(1)	-	3980512 4071258	ED8/A, ED9/A, ES1/A, LH/A, LHB3/A, LHB5, LHE/A, LJ/A, LT/A, LX/A, LXE/A, L1/A, PX/A, P1/A, QH/A, QHB3/A, QHB5, QHP1/A, QMH/A, QP/A, QT/A, QX/A, QXC/A, QXE/A, Q1/A, SH/A, SJ/A, STP/A, STQ/A, SX/A, SXE/A, S1/A, VX/A, VXE/A, VXEB/A, VXU/A, VXU1/A
			1	-	-	3980512	HA2/A, HX26/A, LHQ4/A, LKE/A, LXE2/A, LXE4/A, LXE8/A, LXQ4/A, LXU/A, LX2/A, LX26/A, PKT2/A, PKT4/A, PKX2, PKX4/A, PXA2, PXE8/A, QAB2/A, QAE2/A, QAE6/A, QAG/A, QAH2/A, QAP2/A, QA2/A, QA26/A, QE/A, QHE/A, QHQ4/A, QKA4/A, QMEO/A, QME8/A, QMT2/A, QNE2/A, QNE9/A, QNR2/A, QNR6/A, QTC2/A, QWH2/A, QXB/A, QXB7/A, QXC4/A, QXC6/A, QXC9/A, QXE4/A, QXE6/A, QXE8/A, QXQ4/A, QXU/A, SE/A, SHB3/A, SHQ4/A, SMEO/A, SMX2/A, SWX/A, SXB/A, SXB7/A, SXEB/A, SXE4/A, SXE8/A, SXQ4/A, SXU/A, VA2/A, VXB/A, VXB7/A, VXE2/A, VXE7/A, VXE8/A, VXQ4/A, VX16/A, VX8/A
			1	-	-	4071258	EDK, VXX
	17510-ZE3-800ZD	*R280*.....POWER RED	1	-	-	3980512	4071258 ES1/A
	17510-ZE3-800ZE	*T34*.....SIMPSON BLUE	1	-	-	3980512	QA2/A
	17510-ZE3-800ZF	*T77*.....SEC WINE RED	1	-	-	3980512	ES1/A
	17510-ZE3-800ZG	*Y131*.....LIGHTNING YELLOW	1	-	-	3980512	ES1/A



Ref. No.	Part No.	Description	Reqd. QTY			Serial No.	Parts catalogue code
			(1)	(2)	(3)		
(5)	17510-ZE3-801ZC	TANK COMP., FUEL *NH31*.....MCKINLEY WHITE	1	(1)	-	4071259	----- EDK,ED8/A,ED9/A,ES1/A,LH/A,LHB3/A,LHB5,LHE/A,LJ/A,LT/A,LX/A,LXE/A L1/A,PX/A,P1/A,QH/A,QHB3/A,QHB5,QHP1/A,QMH/A,QP/A,QT/A,QX/A,QXC/A QXE/A,Q1/A,SH/A,SJ/A,STP/A,STQ/A,SWX/SX/SXB,SXE/A,S1/A,VX/A,VXE/A VXEB/A,VXK,VXU/A,VXU1/A
			1	-	-	-----	ES2
	17510-ZE3-801ZD	*R280*.....POWER RED	1	-	-	-----	ES2
			1	-	-	4071259	----- ES1/A
	17510-ZE3-801ZF	*T77*.....SEC WINE RED	1	-	-	-----	ES2
	17510-ZE3-801ZG	*Y131*.....LIGHTNING YELLOW	1	-	-	-----	ES2
6	17620-ZE2-W00	CAP COMP., FUEL FILLER (CHROME PLATED)	1	(1)	-	----- 2302949	BJ,ED7,ED8,ED9,ES,ES1,HA,HAQ,HH,HX,LH,LHC,LHE,LJ,LKE,LP,LX,LXE LXZ,L1,PX,P1,QA,QAE,QAP,QAPE,QAQ,QE,QH,QHC,QHE,QNE,QNE9,QP,QX,QXB QXC,QXE,QXEB,Q1,SE,SH,SHE,SHEZ,SJ,STJ,STP,STQ,SWX,SX,SXB,SXE,SXEB SXP,S1,VA,VDE,VE,VH,VHE,VX,VXB,VXE,VXEB,VXU,VXU1,V1,YJ
			1	-	-	-----	LHB1,LHB3,LT,QHB3,QT,SHB1,SHB3
			1	-	-	3692070	LHB3/A,LHB5,LT/A,QHB3/A,QHB5,QT/A,SHB3/A
7	17620-ZH7-013	CAP COMP., FUEL FILLER .....	1	(1)	-	----- 2302950	4122402 BJ,ED7,ED8,ED9,ES,ES1,HA,HAQ,HH,HX,LH,LHC,LHE,LJ,LKE,LP,LX,LXE LXZ,L1,PX,P1,QA,QAE,QAP,QAPE,QAQ,QE,QH,QHC,QHE,QNE,QNE9,QP,QX,QXB QXC,QXE,QXEB,Q1,SE,SH,SHE,SHEZ,SJ,STJ,STP,STQ,SWX,SX,SXB,SXE,SXEB SXP,S1,VA,VDE,VE,VH,VHE,VX,VXB,VXE,VXEB,VXU,VXU1,V1,YJ
			1	-	-	----- 4122402	HA2,HX2,HX26,LHQ4,LHW,LJG,LSX,LXE2,LXE4,LXE6,LXQ4,LX2,LX26,PKT2 QAE2,QAE6,QAP2,QA2,QA26,QDW9,QHP1,QHQ4,QH2,QMEO,QMT2,QNE2,QNE6 QNR2,QNR6,QN18,QPE2,QTC2,QXC4,QXC6,QXC9,QXE2,QXE4,QXE6,QXQ4,QX2 SDE,SHQ4,SJG,SKZ,SME0,SME2,SMX2,SXE2,SXE4,SXQ4,VA2,VD16,VEB6,VXB2 VXE2,VXE4,VXE6,VXG,VXQ4,VX16
	17620-ZH7-023	CAP COMP., FUEL FILLER (BLACK)	1	(1)	-	----- 4122403	----- BJ,ED7,ED8,ED9,ES,ES1,HA,HAQ,HA2,HH,HX,HX2,HX26,LH,LHC,LHE,LHQ4 LHW,LJ,LJG,LKE,LP,LSX,LX,LXE,LXE2,LXE4,LXE6,LXQ4,LXZ,LX2,LX26,L1 PKT2,PX,P1,QA,QAE,QAE2,QAE6,QAP,QAPE,QAP2,QAQ,QA2,QA26,QDW9,QE,QH QHC,QHE,QHP1,QHQ4,QH2,QMEO,QMT2,QNE,QNE2,QNE6,QNE9,QNR2,QNR6,QN18 QP,QPE2,QTC2,QX,QXB,QXC,QXC4,QXC6,QXC9,QXE,QXEB,QXE2,QXE4,QXE6 QXQ4,QX2,Q1,SDE,SE,SH,SHE,SHEZ,SHQ4,SJ,SJG,SKZ,SME0,SME2,SMX2,STJ STP,STQ,SWX,SX,SXB,SXE,SXEB,SXE2,SXE4,SXP,SXQ4,S1,VA,VA2,VDE,VD16 VE,VEB6,VH,VHE,VX,VXB,VXB2,VXE,VXEB,VXE2,VXE4,VXE6,VXG,VXQ4,VXU VXU1,VX16,V1,YJ
			1	(1)	-	----- 3692070	ED8/A,ED9/A,ES1/A,HA2/A,HX26/A,LH/A,LHE/A,LHQ4/A,LJ/A,LJG/A,LJS/A LKE/A,LWD,LWD1/A,LX/A,LXE/A,LXE2/A,LXE4/A,LXE8/A,LXQ4/A,LXU/A LX2/A,LX26/A,L1/A,PKT2/A,PKT4/A,PKX2,PKX4/A,PX/A,PXE8/A,P1/A QAB2/A,QAE2/A,QAE6/A,QAG/A,QA2/A,QA26/A,QA26/A,QDW9/A,QE/A QH/A,QHE/A,QHP1/A,QHQ4/A,QKA4/A,QMEO/A,QME8/A,QMH/A,QMT2/A,QNE2/A QNE9/A,QNR2/A,QNR6/A,QP/A,QTC2/A,QWH2/A,QX/A,QXB/A,QXB7/A,QXC/A QXC4/A,QXC6/A,QXC9/A,QXE/A,QXE4/A,QXE6/A,QXE8/A,QXQ4/A,QXU/A,Q1/A SE/A,SH/A,SHQ4/A,SJ/A,SJG/A,SKE/A,SKZ/A,SME0/A,SMX2/A,STJ/A,STP/A STQ/A,SWX/A,SX/A,SXB/A,SXB7/A,SXE/A,SXEB/A,SXE4/A,SXE8/A,SXQ4/A SXU/A,S1/A,VA2/A,VX/A,VXB/A,VXB7/A,VXE/A,VXEB/A,VXE2/A,VXE7/A VXE8/A,VXQ4/A,VXU/A,VXU1/A,VX16/A,VX8/A
			1	-	-	-----	LJS,LWD1,LXE8,LXU,PKT4,PKX4,PXE8,QAB2,QAG,QA2,QKA4,QL2,QME8,QMH QMX2,QWH2,QXB7,QXE8,QXU,SKE,SXB7,SXE8,SXU,VMX,VXB7,VXE7,VXE8,VX8



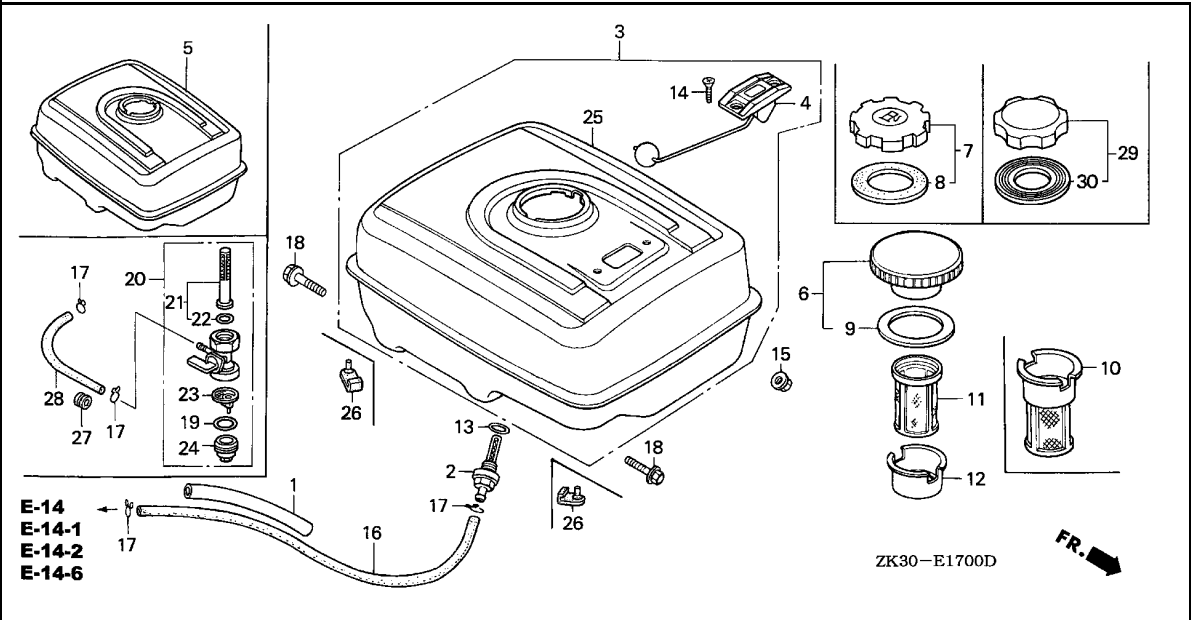

Ref. No.	Part No.	Description	Reqd. QTY			Serial No.	Parts catalogue code
			GX	340K1			
			(1)	(2)	(3)		
8	17631-ZH7-003	PACKING, FUEL FILLER CAP (39X58X3)	1	(1)	-	2302950 -----	BJ, ED7, ED8, ED9, ES, ES1, HA, HAQ, HH, HX, LH, LHC, LHE, LJ, LKE, LP, LX, LXE, LXZ, L1, PX, P1, QA, QAE, QAP, QAPE, QAQ, QE, QH, QHC, QHE, QNE, QNE9, QP, QX, QXB, QXC, QXE, QXEB, Q1, SE, SH, SHE, SHEZ, SJ, STJ, STP, STQ, SWX, SX, SXB, SXE, SXEB, SXP, S1, VA, VDE, VE, VH, VHE, VX, VXB, VXE, VXEB, VXU, VXU1, V1, YJ
			1	(1)	-	----- 3692070	ED8/A, ED9/A, ES1/A, HA2/A, HX26/A, LH/A, LHE/A, LHQ4/A, LJ/A, LJG/A, LJS/A, LKE/A, LWD, LWD1/A, LX/A, LXE/A, LXE2/A, LXE4/A, LXE8/A, LXQ4/A, LXU/A, LX2/A, LX26/A, L1/A, PKT2/A, PKT4/A, PKX2, PKX4/A, PX/A, PXE8/A, P1/A, QAB2/A, QAE2/A, QAE6/A, QAG/A, QAH2/A, QAP2/A, QA2/A, QA26/A, QDW9/A, QE/A, QH/A, QHE/A, QHP1/A, QHQ4/A, QKA4/A, QMED/A, QME8/A, QMH/A, QMT2/A, QNE2/A, QNE9/A, QNR2/A, QNR6/A, QP/A, QTC2/A, QWH2/A, QX/A, QXB/A, QXB7/A, QXC/A, QXC4/A, QXC6/A, QXC9/A, QXE/A, QXE4/A, QXE6/A, QXE8/A, QXQ4/A, QXU/A, Q1/A, SE/A, SH/A, SHQ4/A, SJ/A, SJG/A, SKE/A, SKZ/A, SMED/A, SMX2/A, STJ/A, STP/A, STQ/A, SWX/A, SX/A, SXB/A, SXB7/A, SXE/A, SXEB/A, SXE4/A, SXE8/A, SXQ4/A, SXU/A, S1/A, VA2/A, VX/A, VXB/A, VXB7/A, VXE/A, VXEB/A, VXE2/A, VXE7/A, VXE8/A, VXQ4/A, VXU/A, VXU1/A, VX16/A, VX8/A
			1	-	-	-----	HA2, HX2, HX26, LHQ4, LHW, LJG, LJS, LSX, LWD1, LXE2, LXE4, LXE6, LXE8, LXQ4, LXU, LX2, LX26, PKT2, PKT4, PKX4, PXE8, QAB2, QAE2, QAE6, QAG, QAH2, QAP2, QA2, QA26, QDW9, QHP1, QHQ4, QH2, QKA4, QL2, QMED, QME8, QMH, QMT2, QMX2, QNE2, QNE6, QNR2, QNR6, QN18, QPE2, QTC2, QWH2, QXB7, QXC4, QXC6, QXC9, QXE2, QXE4, QXE6, QXE8, QXQ4, QXU, QX2, SDE, SHQ4, SJG, SKE, SKZ, SMED, SME2, SMX2, SXB7, SXE2, SXE4, SXE8, SXQ4, SXU, VA2, VD16, VEB6, VMX, VXB2, VXB7, VXE2, VXE4, VXE6, VXE7, VXE8, VXG, VXQ4, VX16, VX8



Ref. No.	Part No.	Description	Reqd. QTY			Serial No.	Parts catalogue code
			(1)	(2)	(3)		
9	17631-329-003	PACKING, FUEL FILLER CAP (39X58X3)	1	(1)	-	2302949	BJ, ED7, ED8, ED9, ES, ES1, HA, HAQ, HH, HX, LH, LHC, LHE, LJ, LKE, LP, LX, LXE, LXZ, L1, PX, P1, QA, QAE, QAP, QAPE, QAE, QH, QHC, QHE, QNE, QNE9, QP, QX, QXB, QXC, QXE, QXEB, Q1, SE, SH, SHE, SHEZ, SJ, STJ, STP, STQ, SWX, SX, SXB, SXE, SXEB, SXP, S1, VA, VDE, VE, VH, VHE, VX, VXB, VXE, VXEB, VXU, VXU1, V1, YJ
			1	-	-		LHB1, LHB3, LT, QHB3, QT, SHB1, SHB3
			1	-	-	3692070	LHB3/A, LHB5, LT/A, QHB3/A, QHB5, QT/A, SHB3/A
10	17672-ZE2-W00	FILTER, FUEL .....	1	(1)	-	2146374	BJ, ED7, ES, ES1, HA, LJ, L1, P1, QA, QAE, QAP, QE, QNE, QP, QT, Q1, SE, SJ, STJ, STP, STQ, SWX, S1, VA, VE, V1, YJ
			1	-	-	2084185	QAPE
	17672-ZE2-W01	.....	1	(1)	-		EDK, ED8/A, ED9/A, ES1/A, ES2, HA2, HA2/A, LHB3, LHB3/A, LHB5, LHW, LJ/A, LJG, LJG/A, LJS, LJS/A, LJS1, LSX, LT, LT/A, LWD, L1/A, PKT2, PKT2/A, PKT4, PKT4/A, PKX2, PKX4, PKX4/A, P1/A, QAB2, QAB2/A, QAE2, QAE2/A, QAE6, QAE6/A, QAG, QAG/A, QAH2, QAH2/A, QAP2, QAP2/A, QA2, QA2/A, QA26, QA26/A, QE/A, QHB3, QHB3/A, QHB5, QL2, QME8, QME8/A, QMX2, QNE2, QNE2/A, QNE6, QNE9/A, QNR2, QNR2/A, QNR6, QNR6/A, QN18, QP/A, QPE2, QT/A, QTC2, QTC2/A, Q1/A, SDE, SE/A, SHB3, SHB3/A, SJ/A, SJG, SJG/A, SKE, SKE/A, SKZ, SKZ/A, SME2, SMX2, SMX2/A, STJ/A, STP/A, STQ/A, SWX/A, S1/A, VA2, VA2/A
			1	(1)	-	2242328	BJ, LJ, L1, P1, Q1, SJ, STJ, STP, STQ, S1, V1, YJ
			1	-	-	2240293	ED7, ED8, ED9, ES, ES1, HA, HAQ, QA, QAE, QAP, QAPE, QAE, QNE, QNE9, QP, QT, SE, SWX, VA, VE
11	17672-880-000	FILTER, FUEL .....	1	(1)	-	2146375	2242327 BJ, LJ, L1, P1, Q1, SJ, STJ, STP, STQ, S1, V1, YJ
			1	-	-		2240292 ED8, ED9, HAQ, QAQ, QNE9
			1	-	-	2146375	2240292 ED7, ES, ES1, HA, QA, QAE, QAP, QAPE, QE, QNE, QP, QT, SE, SWX, VA, VE
12	17673-893-000	HOLDER, FUEL FILTER .....	1	(1)	-	2146375	2242327 BJ, LJ, L1, P1, Q1, SJ, STJ, STP, STQ, S1, V1, YJ
			1	-	-		2240292 ED8, ED9, HAQ, QAQ, QNE9
			1	-	-	2146375	2240292 ED7, ES, ES1, HA, QA, QAE, QAP, QAPE, QE, QNE, QP, QT, SE, SWX, VA, VE
13	91353-671-004	O-RING, 14MM(NOK) .....	1	-	-		BJ, EDK, EDS4, ED7, ED8, ED8/A, ED9, ED9/A, ENT2, EN6, EN6/A, ES, ES1, ES1/A, ES2, HA, HAQ, HA2, HA2/A, HH, HX, HX2, HX26, HX26/A, LH, LH/A, LHB1, LHB3, LHB3/A, LHB5, LHC, LHE, LHE/A, LHQ4, LHQ4/A, LHW, LJ, LJ/A, LJG, LJG/A, LJS, LJS/A, LJS1, LKE, LKE/A, LP, LSX, LT, LT/A, LWD, LWD1, LWD1/A, LX, LX/A, LXE, LXE/A, LXE2, LXE2/A, LXE4, LXE4/A, LXE6, LXE6/A, LXE8, LXE8/A, LXQ4, LXQ4/A, LXU, LXU/A, LXZ, LX2, LX2/A, LX26, LX26/A, PKT2, PKT2/A, PKT4, PKT4/A, PKX2, PKX4, PKX4/A, PX, PX/A, PXA2, PXE8, PXE8/A, QA, QAB2, QAB2/A, QAE, QAE2, QAE2/A, QAE6, QAE6/A, QAG, QAG/A, QAH2, QAH2/A, QAP, QAPE, QAP2, QAP2/A, QAQ, QA2, QA2/A, QA26, QA26/A, QDW9, QDW9/A, QE, QE/A, QH, QH/A, QHB3, QHB3/A, QHB5, QHC, QHE, QHE/A, QHP1, QHP1/A, QHQ4, QHQ4/A, QH2, QKA4, QKA4/A, QL2, QMEO, QMEO/A, QME8, QME8/A, QMH, QMH/A, QMT2, QMT2/A, QMX2, QNE, QNE2, QNE2/A, QNE6, QNE9, QNE9/A, QNR2, QNR2/A, QNR6, QNR6/A, QN18, QP, QP/A, QPE2, QT, QT/A, QTC2, QTC2/A, QWH2, QWH2/A, QX, QX/A, QXB, QXB/A, QXB7, QXB7/A, QXC, QXC/A, QXC4, QXC4/A, QXC6, QXC6/A, QXC9, QXC9/A, QXE, QXE/A, QXEB, QXE2, QXE4, QXE4/A, QXE6, QXE6/A, QXE8, QXE8/A, QXQ4, QXQ4/A, QXU, QXU/A, QX2, SDE, SE, SE/A, SH, SH/A, SHB1, SHB3, SHB3/A, SHE, SHEZ, SHQ4, SHQ4/A, SJ, SJ/A, SJG, SJG/A, SKE, SKE/A, SKZ, SKZ/A, SME0, SME0/A, SME2, SMX2, SMX2/A, STJ, STJ/A, STP, STP/A, STQ, STQ/A, SWX, SWX/A, SX, SX/A, SXB, SXB/A, SXB7, SXB7/A, SXE, SXE/A, SXEB, SXEB/A, SXE2, SXE2, SXE4, SXE4/A, SXE8, SXE8/A, SXP, SXQ4, SXQ4/A, SXU, SXU/A, VA, VA2, VA2/A, VDE, VDE2, VDE2/A, VD16, VE, VEB6, VH, VHE, VMQ, VMX, VNG, VSH7, VS4, VS6, VX, VX/A, VXB, VXB/A, VXB2, VXB7, VXB7/A, VXE, VXE/A, VXEB, VXEB/A, VXE2, VXE2/A, VXE4, VXE4, VXE7, VXE7/A, VXE8, VXE8/A, VXG, VXX, VXQ4, VXQ4/A, VXU, VXU/A, VXU1, VXU1/A, VX16, VX16/A, VX8, VX8/A, YJ
			-	(1)	-		
14	93600-05010-0A	SCREW, FLAT, 5X10 .....	2	-	-		LJG, LJG/A, LJS, LJS/A, LJS1, LWD, LWD1, LWD1/A, SDE, SJG, SJG/A, SKE, SKE/A, SKZ/A, STJ, STJ/A, VMQ, VXG
			2	-	-	2599031	SKZ
			-	(2)	-		



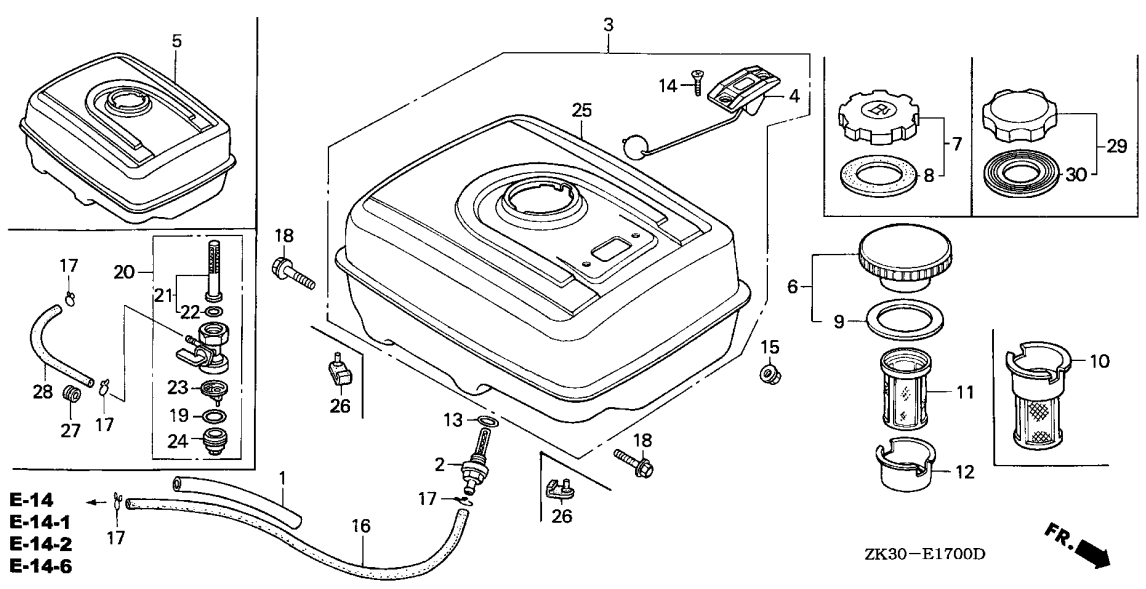

Ref. No.	Part No.	Description	Reqd. QTY			Serial No.	Parts catalogue code
			GX	340K1			
			(1)	(2)	(3)		
15	94050-08000	NUT, FLANGE, 8MM .....	2	-	-	-----	BJ,EDK,EDS4,ED7,ED8,ED8/A,ED9,ED9/A,ENT2,EN6,EN6/A,ES,ES1,ES1/A,ES2,HA,HAQ,HA2,HA2/A,HH,HX,HX2,HX26,HX26/A,LH,LH/A,LHB1,LHB3,LHB3/A,LHB5,LHC,LHE,LHE/A,LHQ4,LHQ4/A,LHW,LJ,LJ/A,LJG,LJG/A,LJS,LJS/A,LJS1,LKE,LKE/A,LP,LSX,LT,LT/A,LWD,LWD1,LWD1/A,LX,LX/A,LXE,LXE/A,LXE2,LXE2/A,LXE4,LXE4/A,LXE6,LXE8,LXE8/A,LXQ4,LXQ4/A,LXU,LXU/A,LXZ,LX2,LX2/A,LX26,LX26/A,PKT2,PKT2/A,PKT4,PKT4/A,PKX2,PKX4,PKX4/A,PX,PX/A,PXA2,PXE8,PXE8/A,QA,QAB2,QAB2/A,QAC2,QAC2/A,QAE,QAE2,QAE2/A,QAE6,QAE6/A,QAG,QAG/A,QA2,QA2/A,QAH2,QAH2/A,QAP,QAPE,QAP2,QAP2/A,QAQ,QA2,QA2/A,QA26,QA26/A,QDW9,QDW9/A,QE,QE/A,QH,QH/A,QHB3,QHB3/A,QHB5,QHC,QHE,QHE/A,QHP1,QHP1/A,QHQ4,QHQ4/A,QH2,QKA4,QKA4/A,QL2,QME0,QME0/A,QME8,QME8/A,QMH,QMH/A,QMT2,QMT2/A,QMX2,QNE,QNE2,QNE2/A,QNE6,QNE9,QNE9/A,QNR2,QNR2/A,QNR6,QNR6/A,QN18,QP,QP/A,QPE2,QT,QT/A,QTC2,QTC2/A,QWH2,QWH2/A,QX,QX/A,QXB,QXB/A,QXB7,QXB7/A,QXC,QXC/A,QXC4,QXC4/A,QXC6,QXC6/A,QXC9,QXC9/A,QXE,QXE/A,QXE2,QXE4,QXE4/A,QXE6,QXE6/A,QXE8,QXE8/A,QXQ4,QXQ4/A,QXU,QXU/A,QX2,SDE,SE,SE/A,SH,SH/A,SHB1,SHB3,SHB3/A,SHE,SHEZ,SHQ4,SHQ4/A,SJ,SJ/A,SJG,SJG/A,SKE,SKE/A,SKZ,SKZ/A,SMEO,SMEO/A,SME2,SMX2,SMX2/A,STJ,STJ/A,STP,STP/A,STQ,STQ/A,SWX,SWX/A,SX,SX/A,SXB,SXB/A,SXB7,SXB7/A,SXE,SXE/A,SXEB,SXEB/A,SXE2,SXE4,SXE4/A,SXE8,SXE8/A,SXP,SXQ4,SXQ4/A,SXU,SXU/A,VA,VA2,VA2/A,VDE,VDE2,VDE2/A,VD16,VE,VEB6,VH,VHE,VMQ,VMX,VS4,VS6,VWE2,VWE2/A,VW12,VW12/A,VX,VX/A,VXB,VXB/A,VXB2,VXB7,VXB7/A,VXE,VXE/A,VXEB,VXEB/A,VXE2,VXE2/A,VXE4,VXE6,VXE7,VXE7/A,VXE8,VXE8/A,VXG,VXK,VXQ4,VXQ4/A,VXU,VXU/A,VXU1,VXU1/A,VX16,VX16/A,VX8,VX8/A,YJ
			-	2	-		

2

Ref. No.	Part No.	Description	Reqd. QTY			Serial No.	Parts catalogue code
			(1)	(2)	(3)		
16	95001-45235-40	TUBE, FUEL, 4.5X235 (95001-45001-60M)	1	-	-	-----	BJ, EDK, ED7, ED8, ED8/A, ED9, ED9/A, ES, ES1, ES1/A, ES2, HA, HAQ, HA2, HA2/A, HH, HX, HX2, HX26, HX26/A, LH, LH/A, LHB1, LHB3, LHB3/A, LHB5, LHC, LHE, LHE/A, LHQ4, LHQ4/A, LHW, LJ, LJ/A, LJG, LJG/A, LJS, LJS/A, LJS1, LKE, LKE/A, LP, LSX, LT, LT/A, LWD, LWD1, LWD1/A, LX, LX/A, LXE, LXE/A, LXE2, LXE2/A, LXE4, LXE4/A, LXE6, LXE8, LXE8/A, LXQ4, LXQ4/A, LXU, LXU/A, LXZ, LXZ, LX2, LX2/A, LX26, LX26/A, PKT2, PKT2/A, PKT4, PKT4/A, PKX2, PKX4, PKX4/A, PX, PX/A, PXA2, PXE8, PXE8/A, QA, QAB2, QAB2/A, QAE, QAE2, QAE2/A, QAE6, QAE6/A, QAG, QAG/A, QAH2, QAH2/A, QAP, QAPE, QAP2, QAP2/A, QAQ, QA2, QA2/A, QA26, QA26/A, QDW9, QDW9/A, QE, QE/A, QH, QH/A, QHB3, QHB3/A, QHB5, QHC, QHE, QHE/A, QHP1, QHP1/A, QHQ4, QHQ4/A, QH2, QKA4, QKA4/A, QL2, QMEO, QMEO/A, QME8, QME8/A, QMH, QMH/A, QMT2, QMT2/A, QMX2, QNE, QNE2, QNE2/A, QNE6, QNE9, QNE9/A, QNR2, QNR2/A, QNR6, QNR6/A, QN18, QP, QP/A, QPE2, QT, QT/A, QTC2, QTC2/A, QWH2, QWH2/A, QX, QX/A, QXB, QXB/A, QXB7, QXB7/A, QXC, QXC/A, QXC4, QXC4/A, QXC6, QXC6/A, QXC9, QXC9/A, QXE, QXE/A, QXEB, QXE2, QXE4, QXE4/A, QXE6, QXE6/A, QXE8, QXE8/A, QXQ4, QXQ4/A, QXU, QXU/A, QX2, SDE, SE, SE/A, SH, SH/A, SHB1, SHB3, SHB3/A, SHE, SHEZ, SHQ4, SHQ4/A, SJ, SJ/A, SJG, SJG/A, SKE, SKE/A, SKZ, SKZ/A, SME0, SME0/A, SME2, SMX2, SMX2/A, STJ, STJ/A, STP, STP/A, STQ, STQ/A, SWX, SWX/A, SX, SX/A, SXB, SXB/A, SXB7, SXB7/A, SXE, SXE/A, SXEB, SXEB/A, SXE2, SXE4, SXE4/A, SXE8, SXE8/A, SXP, SXQ4, SXQ4/A, SXU, SXU/A, VA, VAW1, VA2, VA2/A, VC2, VC2/A, VDE, VDE2, VDE2/A, VD16, VE, VEB6, VH, VHE, VMX, VNG1, VNG2, VSH7, VWC, VWE, VWE2, VWE2/A, VW12, VW12/A, VX, VX/A, VXB, VXB/A, VXB2, VXB7, VXB7/A, VXE, VXE/A, VXEB, VXEB/A, VXE2, VXE2/A, VXE4, VXE6, VXE7, VXE7/A, VXE8, VXE8/A, VXG, VXX, VXQ4, VXQ4/A, VXU, VXU/A, VXX1, VXX1/A, VX16, VX16/A, VX8, VX8/A, YJ
			-	(1)	-		
	95001-45430-40	TUBE, FUEL, 4.5X430 (95001-45001-60M)	1	-	-	-----	QAC2, QAC2/A
	95001-55200-40	TUBE, FUEL, 5.3X200 (95001-55001-60M)	1	-	-	2343603	2616063 ZK1
	95001-55240-40	TUBE, FUEL, 5.3X240 (95001-55001-60M)	1	-	-	-----	ZK1/A
			1	-	-	2616064	ZK1



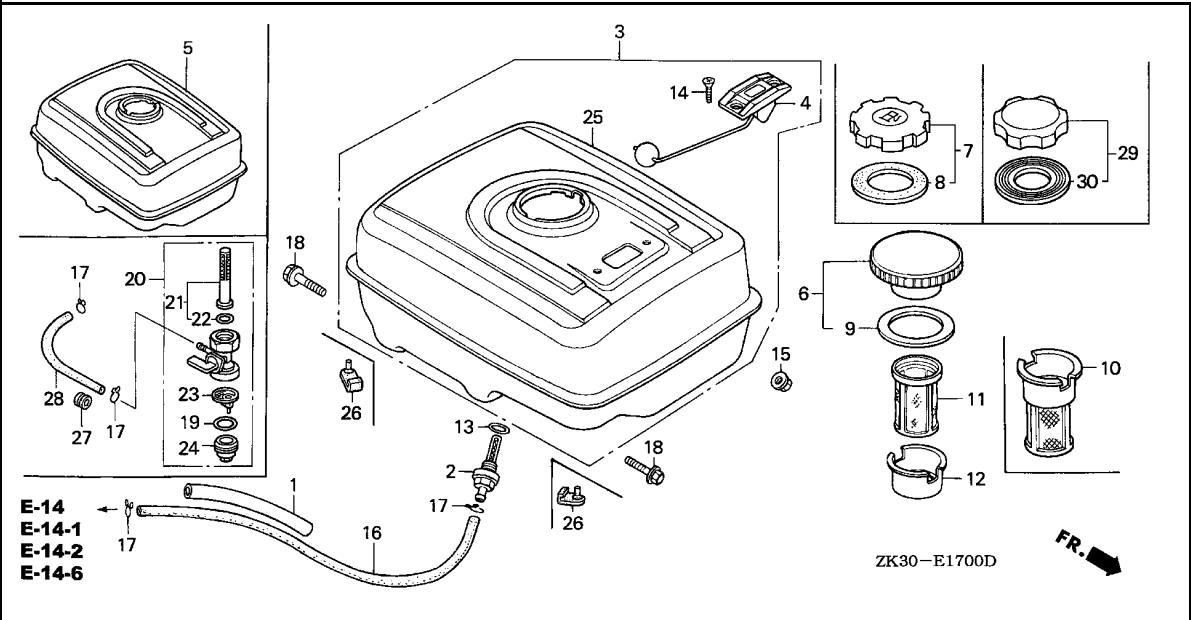

Ref. No.	Part No.	Description	Reqd. QTY			Serial No.	Parts catalogue code
			GX	(1)	(2)		
17	95002-02080	CLIP, TUBE (B8)	2	-	-		BJ,EDK,EDS2,EDS2/A,EDS4,EDT2,ED7,ED8,ED8/A,ED9,ED9/A,ENT2,EN6,EN6/A,ES,ES1,ES1/A,ES2,HA,HAQ,HA2,HA2/A,HH,HX,HX2,HX26/A,LH,LH/A,LHB1,LHB3,LHB3/A,LHB5,LHC,LHE,LHE/A,LHQ4,LHQ4/A,LHW,LJ,LJ/A,LJG,LJG/A,LJS,LJS/A,LJS1,LKE,LKE/A,LP,LSX,LT,LT/A,LWD,LWD1,LWD1/A,LX,LX/A,LXE,LXE/A,LXE2,LXE2/A,LXE4,LXE4/A,LXE6,LXE8,LXE8/A,LXQ4,LXQ4/A,LXU,LXU/A,LXZ,LX2,LX2/A,LX26,LX26/A,PKT2,PKT2/A,PKT4,PKT4/A,PKX2,PKX4,PKX4/A,PX,PX/A,PXA2,PXE8,PXE8/A,QA,QAB2,QAB2/A,QAC2,QAC2/A,QAE,QAE2,QAE2/A,QAE6,QAE6/A,QAG,QAG/A,QA2,QA2/A,QAP,QAPE,QAP2,QAP2/A,QAQ,QA2,QA2/A,QA26,QA26/A,QDW9,QDW9/A,QE,QE/A,QH,QH/A,QHB3,QHB3/A,QHB5,QHC,QHE,QHE/A,QHP1,QHP1/A,QHQ4,QHQ4/A,QHZ,QKA4,QKA4/A,QL2,QMEO,QMEO/A,QME8,QME8/A,QMH,QMH/A,QMT2,QMT2/A,QMX2,QNE,QNE2,QNE2/A,QNE6,QNE9,QNE9/A,QNR2,QNR2/A,QNR6,QNR6/A,QN18,QP,QP/A,QPE2,QT,QT/A,QTC2,QTC2/A,QWH2,QWH2/A,QX,QX/A,QXB,QXB/A,QXB7,QXB7/A,QXC,QXC/A,QXC4,QXC4/A,QXC6,QXC6/A,QXC9,QXC9/A,QXE,QXE/A,QXEB,QXE2,QXE4,QXE4/A,QXE6,QXE6/A,QXE8,QXE8/A,QXQ4,QXQ4/A,QXU,QXU/A,QX2,SDE,SE,SE/A,SH,SH/A,SHB1,SHB3,SHB3/A,SHE,SHEZ,SHQ4,SHQ4/A,SJ,SJ/A,SJG,SJG/A,SKE,SKE/A,SKZ,SKZ/A,SME0,SME0/A,SME2,SMX2,SMX2/A,STJ,STJ/A,STP,STP/A,STQ,STQ/A,SWX,SWX/A,SX,SX/A,SXB,SXB/A,SXB7,SXB7/A,SXE,SXE/A,SXEB,SXEB/A,SXE2,SXE4,SXE4/A,SXE8,SXE8/A,SXP,SXQ4,SXQ4/A,SXU,SXU/A,VA,VAW1,VA2,VA2/A,VC2,VC2/A,VDE,VDE2,VDE2/A,VD16,VE,VEB6,VH,VHE,VMQ,VMX,VNG1,VNG2,VSH7,VS4,VS6,VMC,VME,VME2,VWE2/A,VW12,VW12/A,VX,VX/A,VXB,VXB/A,VXB2,VXB7,VXB7/A,VXE,VXE/A,VXEB,VXEB/A,VXE2,VXE2/A,VXE4,VXE6,VXE7,VXE7/A,VXE8,VXE8/A,VXG,VXK,VXQ4,VXQ4/A,VXU,VXU/A,VXU1,VXU1/A,VX16/VX16/A,VX8,VX8/A,YJ
	90603-ZV4-000	CLIP, TUBE (B10)	2	(2)	-		ZK1/A ZK1

2



Ref. No.	Part No.	Description	Reqd. QTY			Serial No.	Parts catalogue code
			(1)	(2)	(3)		
18	95701-08025-00	BOLT, FLANGE, 8X25 .....	2	-	-	-----	BJ,EDK,ED7,ED8,ED8/A,ED9,ED9/A,ES,ES1,ES1/A,ES2,HA,HAQ,HA2,HA2/A,HH,HX,HX2,HX26,HX26/A,LH,LH/A,LHB1,LHB3,LHB3/A,LHB5,LHC,LHE,LHE/A,LHQ4,LHQ4/A,LHW,LJ,LJ/A,LJG,LJG/A,LJS,LJS/A,LJS1,LKE,LKE/A,LP,LSX,LT,LT/A,LX,LX/A,LXE,LXE/A,LXE2,LXE2/A,LXE4,LXE4/A,LXE6,LXE8,LXE8/A,LXQ4,LXQ4/A,LXU,LXU/A,LXZ,LX2,LX2/A,LX26,LX26/A,PKT2,PKT2/A,PKT4,PKT4/A,PKX2,PKX4,PKX4/A,PX,PX/A,PXA2,PXE8,PXE8/A,QA,QAB2,QAB2/A,QAE,QAE2,QAE2/A,QAE6,QAE6/A,QAG,QAG/A,QA2,QA2/A,QAP,QAPE,QAP2,QAP2/A,QAQ,QA2,QA2/A,QA26,QA26/A,QDW9,QDW9/A,QE,QE/A,QH,QH/A,QHB3,QHB3/A,QHB5,QHC,QHE,QHE/A,QHP1,QHP1/A,QHQ4,QHQ4/A,QH2,QKA4,QKA4/A,QL2,QMED,QMED/A,QME8,QME8/A,QMH,QMH/A,QMT2,QMT2/A,QMX2,QNE,QNE2,QNE2/A,QNE6,QNE9,QNE9/A,QNR2,QNR2/A,QNR6,QNR6/A,QN18,QP,QP/A,QPE2,QT,QT/A,QTC2,QTC2/A,QWH2,QWH2/A,QX,QX/A,QXB,QXB/A,QXB7,QXB7/A,QXC,QXC/A,QXC4,QXC4/A,QXC6,QXC6/A,QXC9,QXC9/A,QXE,QXE/A,QXEB,QXE2,QXE4,QXE4/A,QXE6,QXE6/A,QXE8,QXE8/A,QXQ4,QXQ4/A,QXU,QXU/A,QX2,SDE,SE,SE/A,SH,SH/A,SHB1,SHB3,SHB3/A,SHE,SHEZ,SHQ4,SHQ4/A,SJ,SJ/A,SJG,SJG/A,SKE,SKE/A,SKZ,SKZ/A,SME0,SME0/A,SME2,SMX2,SMX2/A,STJ,STJ/A,STP,STP/A,STQ,STQ/A,SWX,SWX/A,SX,SX/A,SXB,SXB/A,SXB7,SXB7/A,SXE,SXE/A,SXEB,SXEB/A,SXE2,SXE4,SXE4/A,SXE8,SXE8/A,SXP,SXQ4,SXQ4/A,SXU,SXU/A,VA,VA2,VA2/A,VD16,VE,VEB6,VH,VHE,VMX,VX,VX/A,VXB,VXB/A,VXB2,VXB7,VXB7/A,VXE,VXE/A,VXEB,VXEB/A,VXE2,VXE2/A,VXE4,VXE6,VXE7,VXE7/A,VXE8,VXE8/A,VXG,VXK,VXQ4,VXQ4/A,VXU,VXU/A,VXU1,VXU1/A,VX16,VX16/A,VX8,VX8/A,YJ
	95701-08028-00	BOLT, FLANGE, 8X28 .....	-	(2)	-	-----	LWD,LWD1,LWD1/A
19	16173-001-004	PACKING, FUEL STRAINER CUP ..	2	-	-	-----	EDK,EDS2,EDS2/A,EDT2,VXK
20	16950-ZB4-015	COCK ASSY., FUEL .....	1	-	-	-----	EDS2,EDS2/A,EDT2
21	16952-ZB4-005	SCREEN, FUEL STRAINER .....	1	-	-	-----	EDS2,EDS2/A,EDT2
22	16958-397-771	O-RING .....	1	-	-	-----	EDS2,EDS2/A,EDT2
23	16959-471-831	FILTER, CUP .....	1	-	-	-----	EDS2,EDS2/A,EDT2
24	16967-GA6-671	CUP, FUEL STRAINER .....	1	-	-	-----	EDS2,EDS2/A,EDT2
25	17510-ZE3-810	TANK COMP., FUEL (GAUGE) ....	-	(1)	-	-----	L1,L1/A,Q1,Q1/A,S1,S1/A,V1
26	50319-ZB2-000	RUBBER, TANK MOUNTING .....	2	-	-	-----	EDS2,EDS2/A,EDS4,EDT2
27	90854-ZB2-000	RUBBER, FUEL (9X15X10) .....	1	-	-	-----	EDS2,EDS2/A,EDS4,EDT2,ENT2,VS4,VS6
28	95001-45150-40	TUBE, FUEL, 4.5X150 (95001-45001-60M)	1	-	-	-----	EDS2,EDS2/A,EDS4,EDT2,VS4,VS6
	95001-45165-40	TUBE, FUEL, 4.5X165 (95001-45001-60M)	1	-	-	-----	ENT2
29	17620-Z0T-305	CAP COMP., FUEL FILLER (CHROME PLATED)	1	(1)	-	3692071 -----	ED8/A,ED9/A,ES1/A,HA2/A,HX26/A,LH/A,LHB3/A,LHB5,LHE/A,LHQ4/A,LJ/A,LJG/A,LJS/A,LKE/A,LT/A,LWD,LWD1/A,LX/A,LXE/A,LXE2/A,LXE4/A,LXE8/A,LXQ4/A,LXU/A,LX2/A,LX26/A,L1/A,PKT2/A,PKT4/A,PKX2,PKX4/A,PX/A,PXE8/A,P1/A,QAB2/A,QAE2/A,QAE6/A,QAG/A,QA2,QA2/A,QA26/A,QA26/A,QDW9/A,QE/A,QH/A,QHB3/A,QHB5,QHE/A,QHP1/A,QHQ4/A,QKA4/A,QMED/A,QME8/A,QMH/A,QMT2/A,QNE2/A,QNE9/A,QNR2/A,QNR6/A,QP/A,QT/A,QTC2/A,QWH2/A,QX/A,QXB/A,QXB7/A,QXC/A,QXC4/A,QXC6/A,QXC9/A,QXE/A,QXE4/A,QXE6/A,QXE8/A,QXQ4/A,QXU/A,Q1/A,SE/A,SH/A,SHB3/A,SHQ4/A,SJ/A,SJG/A,SKE/A,SKZ/A,SME0/A,SMX2/A,STJ/A,STP/A,STQ/A,SWX/A,SX/A,SXB/A,SXB7/A,SXE/A,SXEB/A,SXE4/A,SXE8/A,SXQ4/A,SXU/A,S1/A,VA2/A,VX/A,VXB/A,VXB7/A,VXE/A,VXEB/A,VXE2/A,VXE7/A,VXE8/A,VXQ4/A,VXU/A,VXU1/A,VX16/A,VX8/A
	17620-Z0T-814	.....	1	-	-	-----	EDK,ES2,LJS1,PXA2,VXK
		.....	1	-	-	-----	EDK,VXK



E-17

FUEL TANK(1)

2-D 8

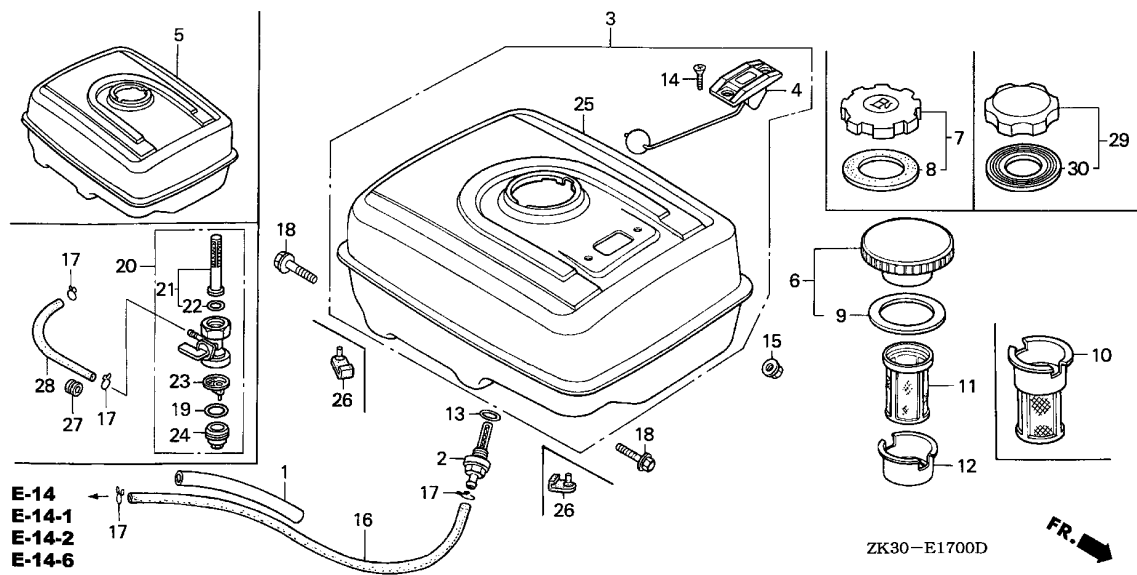

Ref. No.	Part No.	Description	Reqd. QTY			Serial No.	Parts catalogue code
			GX	(1)	(2)		
30	17631-Z0T-812	PACKING, FUEL FILLER CAP (39X62X3)	1	(1)	-	3692071	----- ED8/A,ED9/A,ES1/A,HA2/A,HX26/A,LH/A,LHB3/A,LHB5,LHE/A,LHQ4/A,LJ/A,LJG/A,LJS/A,LKE/A,LT/A,LWD,LWD1/A,LX/A,LXE/A,LXE2/A,LXE4/A,LXE8/A,LXQ4/A,LXU/A,LX2/A,LX26/A,L1/A,PKT2/A,PKT4/A,PKX2,PKX4/A,PX/A,PXE8/A,P1/A,QAB2/A,QAE2/A,QAE6/A,QAG/A,QA2/A,QA26/A,QD9/A,QE/A,QH/A,QHB3/A,QHB5,QHE/A,QHP1/A,QHQ4/A,QKA4/A,QME0/A,QME8/A,QMH/A,QMT2/A,QNE2/A,QNE9/A,QNR2/A,QNR6/A,QP/A,QT/A,QTC2/A,QWH2/A,QX/A,QXB/A,QXB7/A,QXC/A,QXC4/A,QXC6/A,QXC9/A,QXE/A,QXE4/A,QXE6/A,QXE8/A,QXQ4/A,QXU/A,Q1/A,SE/A,SH/A,SHB3/A,SHQ4/A,SJ/A,SJG/A,SKE/A,SKZ/A,SME0/A,SMX2/A,STJ/A,STP/A,STQ/A,SWX/A,SX/A,SXB/A,SXB7/A,SXE/A,SXEB/A,SXE4/A,SXE8/A,SXQ4/A,SXU/A,S1/A,VA2/A,VX/A,VXB/A,VXB7/A,VXE/A,VXEB/A,VXE2/A,VXE7/A,VXE8/A,VXQ4/A,VXU/A,VXU1/A,VX16/A,VX8/A
			1	-	-	-----	EDK,ES2,LJS1,PXA2,VXK

E-17-1

FUEL TANK(2)

2-D 9

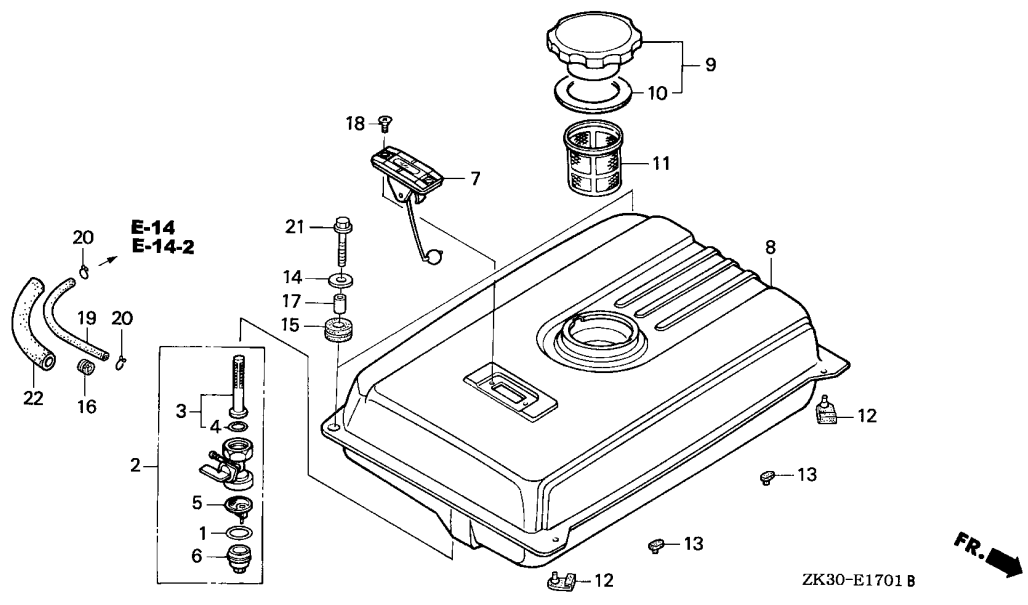

Ref. No.	L.O.N.	(Relative ref. Number) Description	F.R.T.
2	3101A3	COCK, FUEL .....	0.2
3	3101D5	SCREEN, FUEL STRAINER .....	0.2
5		(1,6)	
	3101A7	FILTER, FUEL TANK CUP .....	0.2
7	6171A1	METER/GAUGE UNIT, FUEL .....	0.1
8	3101D0	TANK, FUEL(A) .....	0.3
11	3101A6	FILTER, FUEL .....	0.1
19	3101F2	TUBE, FUEL COCK .....	0.2

Ref. No.	Part No.	Description	Reqd. QTY			Serial No.	Parts catalogue code
			GX	(1)	(2)		
1	16173-001-004	PACKING, FUEL STRAINER CUP ..	1	-	-	-----	EDE2,EDE2/A,EDN,EDN2,EDN2/A,EDN5,EDN5/A,EDS,EDS1,EDS1/A,EDS3,EDS6,EDS6/A,EDT1,EDT1/A,EDT6,EDT6/A,ED6,ED6/A,EMT,EMT/A,ES3,ES3/A,ES4,ES4/A,SHT,STR,STR/A,VAA,VAE,VMQ,VMT,VMT/A,VTE2,VXA
2	16950-ZB4-015	COCK ASSY., FUEL .....	1	-	-	-----	EDE2,EDE2/A,EDN,EDN2,EDN2/A,EDN5,EDN5/A,EDS,EDS1,EDS1/A,EDS3,EDS6,EDS6/A,EDT1,EDT1/A,EDT6,EDT6/A,ED6,ED6/A,EMT,EMT/A,ES3,ES3/A,ES4,ES4/A,SHT,STR,STR/A,VAA,VAE,VMQ,VMT,VMT/A,VTE2,VXA
3	16952-ZB4-005	SCREEN, FUEL STRAINER .....	1	-	-	-----	EDE2,EDE2/A,EDN,EDN2,EDN2/A,EDN5,EDN5/A,EDS,EDS1,EDS1/A,EDS3,EDS6,EDS6/A,EDT1,EDT1/A,EDT6,EDT6/A,ED6,ED6/A,EMT,EMT/A,ES3,ES3/A,ES4,ES4/A,SHT,STR,STR/A,VAA,VAE,VMQ,VMT,VMT/A,VTE2,VXA
4	16958-397-771	O-RING .....	1	-	-	-----	EDE2,EDE2/A,EDN,EDN2,EDN2/A,EDN5,EDN5/A,EDS,EDS1,EDS1/A,EDS3,EDS6,EDS6/A,EDT1,EDT1/A,EDT6,EDT6/A,ED6,ED6/A,EMT,EMT/A,ES3,ES3/A,ES4,ES4/A,SHT,STR,STR/A,VAA,VAE,VMQ,VMT,VMT/A,VTE2,VXA
5	16959-471-831	FILTER, CUP .....	1	-	-	-----	EDE2,EDE2/A,EDN,EDN2,EDN2/A,EDN5,EDN5/A,EDS,EDS1,EDS1/A,EDS3,EDS6,EDS6/A,EDT1,EDT1/A,EDT6,EDT6/A,ED6,ED6/A,EMT,EMT/A,ES3,ES3/A,ES4,ES4/A,SHT,STR,STR/A,VAA,VAE,VMQ,VMT,VMT/A,VTE2,VXA
6	16967-GA6-671	CUP, FUEL STRAINER .....	1	-	-	-----	EDE2,EDE2/A,EDN,EDN2,EDN2/A,EDN5,EDN5/A,EDS,EDS1,EDS1/A,EDS3,EDS6,EDS6/A,EDT1,EDT1/A,EDT6,EDT6/A,ED6,ED6/A,EMT,EMT/A,ES3,ES3/A,ES4,ES4/A,SHT,STR,STR/A,VAA,VAE,VMQ,VMT,VMT/A,VTE2,VXA
7	17505-ZB2-003	METER ASSY., FUEL .....	1	-	-	-----	EDS,EDS5,ED6,ED6/A,EMT,EMT/A,ES3,ES3/A,ES4,ES4/A,SHT,STR,STR/A,VAA,VAE,VMQ,VMT,VMT/A,VTE2,VXA
8	17510-ZB4-000ZB	TANK COMP., FUEL	1	-	-	-----	EDS,ED6,SHT,STR,VTE2
	*R8*	.....BRIGHT RED	1	-	-	-----	3295327 VMT
			1	-	-	-----	3678708 ED6/A,STR/A
	17510-ZB4-000ZC	*NH1*.....BLACK	1	-	-	-----	ED6,ED6/A,ENT,ENT/A
	17510-ZB4-000ZE	*T68*.....TSURUMI BLUE	1	-	-	-----	EDT,EDT/A,ED6,ED6/A
	17510-ZB4-000ZF	*Y131*.....LIGHTNING YELLOW	1	-	-	-----	ED6,ED6/A,ENT,ENT/A
	17510-ZB7-000	.....	1	-	-	-----	EDS5

2

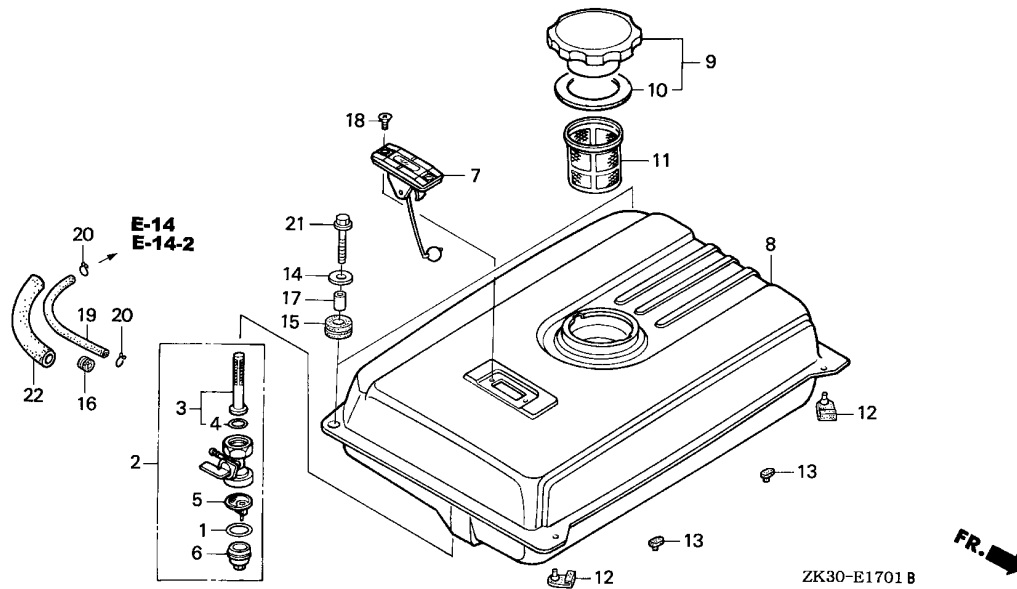

Ref. No.	Part No.	Description	Reqd. QTY			Serial No.	Parts catalogue code
			GX	(1)	(2)		
(8)	17510-ZC2-000ZA	TANK COMP., FUEL	1	-	-	-----	VXA
		*NH31*.....MCKINLEY WHITE	1	-	-	-----	VAA,VA AE
	17510-ZC2-000ZC	*R8*.....BRIGHT RED	1	-	-	3295328	VMT
			1	-	-	-----	VMT/A
	17510-ZB4-000ZH	*R280*.....POWER RED	1	-	-	3678709	ED6/A,STR/A
	17510-ZC2-000ZJ	*R280*.....POWER RED	1	-	-	3680597	VMT/A
9	17620-899-013	CAP COMP., FUEL FILLER	1	-	-	-----	EDS,EDS5,ED6,ED6/A,EMT,EMT/A,ES3,ES3/A,ES4,ES4/A,SHT,STR,STR/A VAA,VA AE,VMQ,VMT,VMT/A,VTE2,VXA
10	17631-899-000	PACKING, FUEL FILLER CAP	1	-	-	-----	EDS,EDS5,ED6,ED6/A,EMT,EMT/A,ES3,ES3/A,ES4,ES4/A,SHT,STR,STR/A VAA,VA AE,VMQ,VMT,VMT/A,VTE2,VXA
11	17670-899-000	FILTER COMP., FUEL	1	-	-	-----	EDS,ED6,ED6/A,EMT,EMT/A,ES3,ES3/A,ES4,ES4/A,SHT,STR,STR/A,VMT VMT/A,VTE2,VXA
	17672-899-000	FILTER, FUEL	1	-	-	-----	VMQ
12	50319-ZB2-000	RUBBER, TANK MOUNTING	2	-	-	-----	EDS,EDS1,EDS1/A,EDS3,EDS6,EDS6/A,EDT1,EDT1/A,EDT6,EDT6/A,ED6 ED6/A,EMT,EMT/A,ES3,ES3/A,ES4,ES4/A,SHT,STR,STR/A,VAA,VA AE,VMQ VMT,VMT/A,VTE2
13	76122-952-000	STOPPER, DISCHARGE GUARD	2	-	-	-----	EDS,ED6,ED6/A,SHT
14	90503-898-000	WASHER, TANK CUSHION	2	-	-	-----	EDS,ED6,ED6/A,ES3,ES3/A,ES4,ES4/A,SHT,STR,STR/A,VAA,VA AE,VMT VMT/A,VTE2
15	90851-898-000	RUBBER, TANK CUSHION	2	-	-	-----	EDS,ED6,ED6/A,EMT,EMT/A,ES3,ES3/A,ES4,ES4/A,SHT,STR,STR/A,VAA VA AE,VMQ,VMT,VMT/A,VTE2
16	90854-ZB2-000	RUBBER, FUEL (9X15X10)	1	-	-	-----	EDE2,EDE2/A,EDN,EDN2,EDN2/A,EDS,EDS1,EDS1/A,EDS3,EDS6,EDS6/A,EDT1 EDT1/A,EDT6,EDT6/A,ED6,ED6/A,EMT,EMT/A,ES3,ES3/A,ES4,ES4/A,SHT VMQ,VMT,VMT/A,VS2,VS7,VTE2
17	91551-898-000	COLLAR, TANK CUSHION	2	-	-	-----	EDS,ED6,ED6/A,EMT,EMT/A,ES3,ES3/A,ES4,ES4/A,SHT,STR,STR/A,VAA VA AE,VMQ,VMT,VMT/A,VTE2

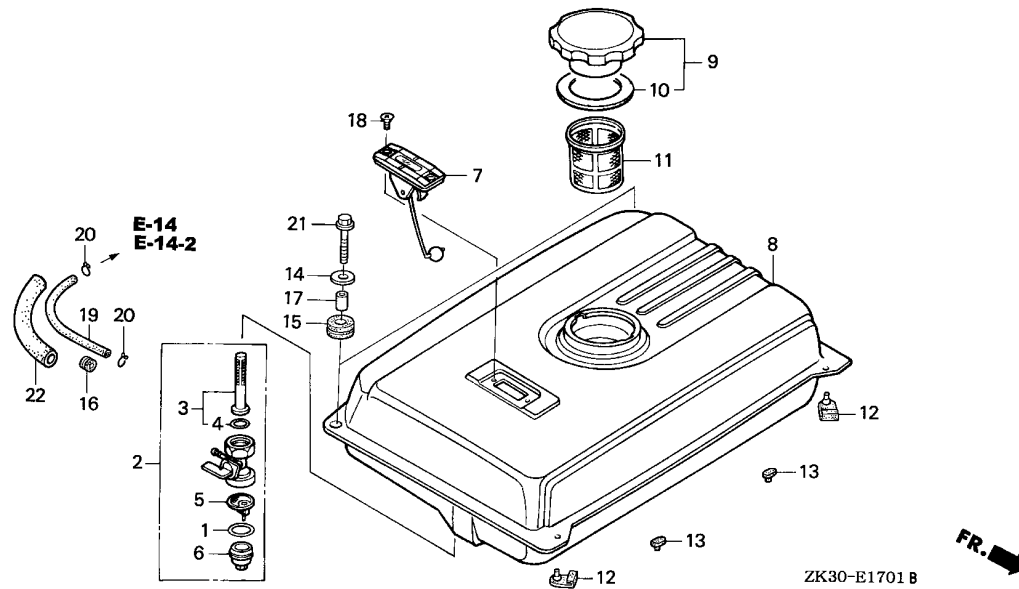

Ref. No.	Part No.	Description	Reqd. QTY			Serial No.	Parts catalogue code
			GX	340K1			
			(1)	(2)	(3)		
18	93600-05010-0A	SCREW, FLAT, 5X10 .....	2	-	-	-----	EDS,EDS5,ED6,ED6/A,EMT,EMT/A,ES3,ES3/A,ES4,ES4/A,SHT,STR,STR/A VAA,VAAE,VMQ,VMT,VMT/A,VTE2,VXA
19	95001-45150-40	TUBE, FUEL, 4.5X150 (95001-45001-60M)	1	-	-	-----	EDS,EDS1,EDS3,EDS6,EDS6/A,EDT1,EDT6,EDT6/A,ES3,ES3/A,ES4,ES4/A VS2,VS7
	95001-45300-40	TUBE, FUEL, 4.5X300 (95001-45001-60M)	1	-	-	4088023	EDS1/A,EDT1/A
	95001-45165-40	TUBE, FUEL, 4.5X165 (95001-45001-60M)	1	-	-	4088024	SHT
	95001-45260-40	TUBE, FUEL, 4.5X260 (95001-45001-60M)	1	-	-	2589845	ED6
	95001-45190-40	TUBE, FUEL, 4.5X190 (95001-45001-60M)	1	-	-	2589846	EDN,ED6/A,VTE2 ED6
	95001-45210-40	TUBE, FUEL, 4.5X210 (95001-45001-60M)	1	-	-	-----	EDE2,EDE2/A,EDN2,EDN2/A
	95001-45250-40	TUBE, FUEL, 4.5X250 (95001-45001-60M)	1	-	-	-----	EMT,EMT/A,VMQ,VMT,VMT/A
	95001-45300-40	TUBE, FUEL, 4.5X300 (95001-45001-60M)	1	-	-	-----	STR,STR/A
20	95002-02080	CLIP, TUBE (B8) .....	2	-	-	-----	EDE2,EDE2/A,EDN,EDN2,EDN2/A,EDS,EDS1,EDS1/A,EDS3,EDS6,EDS6/A,EDT1 EDT1/A,EDT6,EDT6/A,ED6,ED6/A,EMT,EMT/A,ES3,ES3/A,ES4,ES4/A,SHT STR,STR/A,VMQ,VMT,VMT/A,VS2,VS7,VTE2
21	95701-06022-00	BOLT, FLANGE, 6X22 .....	2	-	-	-----	EDS,ED6,ED6/A,ES3,ES3/A,ES4,ES4/A,SHT,VAA,VAAE,VTE2
22	16854-ZH8-000	RUBBER, SUPPORTER (107MM) ...	1	-	-	-----	STR,STR/A



# E-17-2

# FUEL TANK(3)

**2-D12**

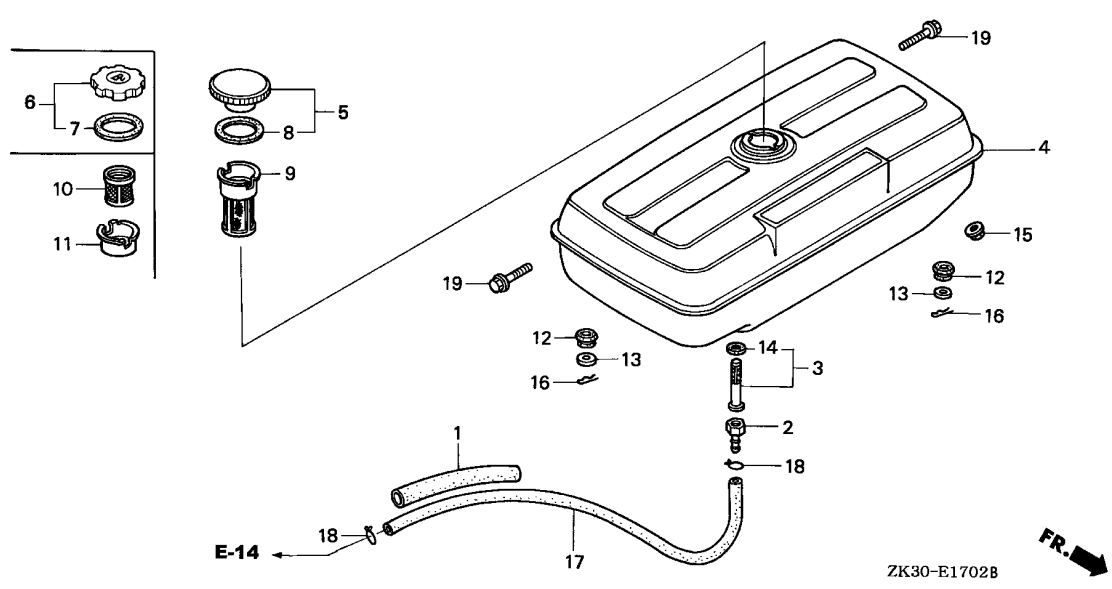

Ref. No.	L.O.N.	(Relative ref. Number) Description	F.R.T.
3		(2,14)	
3101D4		SCREEN SET .....	0.2
4		3101H7 TANK, FUEL .....	0.2
9		(10)	
3101A6		FILTER, FUEL .....	0.1
17		3101F1 TUBE, FUEL TANK .....	0.2

**2**

Ref. No.	Part No.	Description	Reqd. QTY			Serial No.	Parts catalogue code
			GX	340K1			
			(1)	(2)	(3)		
1	16854-ZH8-000	RUBBER, SUPPORTER (107MM) ...	1	-	-	-----	EN,ET,ETS,ETX
2	16950-732-000	JOINT, FUEL .....	1	-	-	-----	EN,ET,ETS,ETX
3	16952-883-005	SCREEN SET .....	1	-	-	-----	EN,ET,ETS,ETX
4	17510-893-000ZB	TANK COMP., FUEL					
5	17620-ZE2-W00	*R8*.....BRIGHT RED CAP COMP., FUEL FILLER (CHROME PLATED)	1	-	-	-----	EN,ET,ETS,ETX
			1	-	-	2302949	EN,ET,ETS,ETX
6	17620-ZH7-013	CAP COMP., FUEL FILLER .....	1	-	-	2302950	4122402 EN,ET,ETS,ETX
	17620-ZH7-023	CAP COMP., FUEL FILLER (BLACK)	1	-	-	4122403	----- EN,ET,ETS,ETX
7	17631-ZH7-003	PACKING, FUEL FILLER CAP (39X58X3)	1	-	-	2302950	----- EN,ET,ETS,ETX
8	17631-329-003	PACKING, FUEL FILLER CAP (39X58X3)	1	-	-	-----	2302949 EN,ET,ETS,ETX
9	17672-ZE2-W01	FILTER, FUEL .....	1	-	-	2240293	----- EN,ET,ETS,ETX
10	17672-880-000	FILTER, FUEL .....	1	-	-	-----	2240292 EN,ET,ETS,ETX
11	17673-893-000	HOLDER, FUEL FILTER .....	1	-	-	-----	2240292 EN,ET,ETS,ETX
12	17682-817-020	RUBBER, TANK CUSHION .....	4	-	-	-----	EN,ET,ETS,ETX
13	90506-500-000	WASHER, AIR DUCT .....	4	-	-	-----	EN,ET,ETS,ETX
14	91353-671-004	O-RING, 14MM(NOK) .....	1	-	-	-----	2362399 EN,ET,ETS,ETX
15	94050-08000	NUT, FLANGE, 8MM .....	2	-	-	-----	2362399 EN,ET,ETS,ETX
16	94251-08000	PIN, LOCK, 8MM .....	4	-	-	-----	EN,ET,ETS,ETX
17	95001-45430-40	TUBE, FUEL, 4.5X430 (95001-45001-60M)	1	-	-	-----	EN,ET,ETS,ETX
18	95002-02080	CLIP, TUBE (B8) .....	2	-	-	-----	EN,ET,ETS,ETX
19	95701-08025-00	BOLT, FLANGE, 8X25 .....	2	-	-	-----	2362399 EN,ET,ETS,ETX

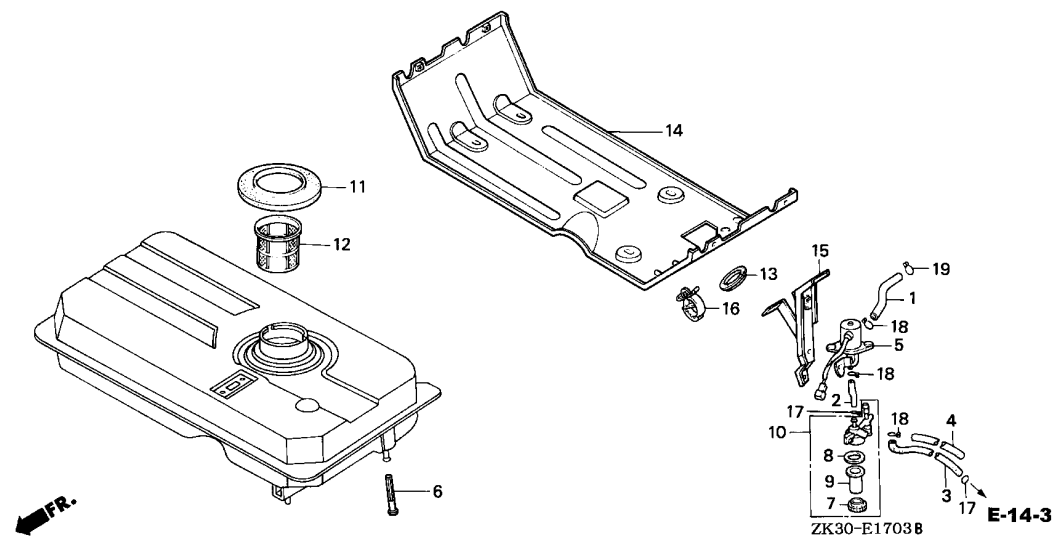

Ref. No.	L.O.N.	(Relative ref. Number) Description	F.R.T.
1	3101F2	TUBE, FUEL COCK .....	0.2
5	3101H0	VALVE, ELECTRIC FUEL .....	0.2
6	3101H8	STRAINER, FUEL .....	0.2
10		(9)	
	3101F4	CUP, FUEL STRAINER .....	0.2
12	3101A6	FILTER, FUEL .....	0.1
14	4141J4	PLATE, FUEL TANK HANGER .....	0.2

Ref. No.	Part No.	Description	Reqd. QTY			Serial No.	Parts catalogue code
			GX 340K1 (1)	(2)	(3)		
1	16851-ZB7-000	TUBE, FUEL (TANK-COCK) .....	1	-	-	-----	EDS5
2	16852-ZB7-000	TUBE, FUEL (COCK-STRAINER) ..	1	-	-	-----	EDS5
3	16853-ZB7-000	TUBE, FUEL (STRAINER-CARBURETOR)	1	-	-	-----	EDS5
4	16857-ZB7-000	TUBE, FUEL SUPPORTER .....	1	-	-	-----	EDS5
5	16930-ZB7-013	COCK ASSY., ELECTRIC FUEL ...	1	-	-	-----	EDS5
6	16952-ZB7-000	STRAINER, FUEL .....	1	-	-	-----	EDS5
7	16957-707-005	NUT, RING .....	1	-	-	-----	EDS5
8	16963-443-901	GASKET .....	1	-	-	-----	EDS5
9	16967-196-005	CUP, FUEL STRAINER .....	1	-	-	-----	EDS5
10	16990-ZB7-005	CUP ASSY., FUEL STRAINER ....	1	-	-	-----	EDS5
11	17520-ZA0-800	SEAL, FUEL FILLER NECK .....	1	-	-	-----	EDS5
12	17672-899-000	FILTER, FUEL .....	1	-	-	-----	EDS5
13	32112-611-000	GROMMET, WIRE CORD .....	1	-	-	-----	EDS5
14	63125-ZB7-000	PLATE, FUEL TANK HANGER .....	1	-	-	-----	EDS5
15	63132-ZB7-000	BRACKET, STRAINER CUP SETTING	1	-	-	-----	EDS5
16	90684-ZA0-601	CLIP, HARNESS .....	1	-	-	-----	EDS5
17	95002-02080	CLIP, TUBE (B8) .....	2	-	-	-----	EDS5
18	95002-02100	CLIP, TUBE (B10) .....	3	-	-	-----	EDS5
19	95002-02120	CLIP, TUBE (B12) .....	1	-	-	-----	EDS5



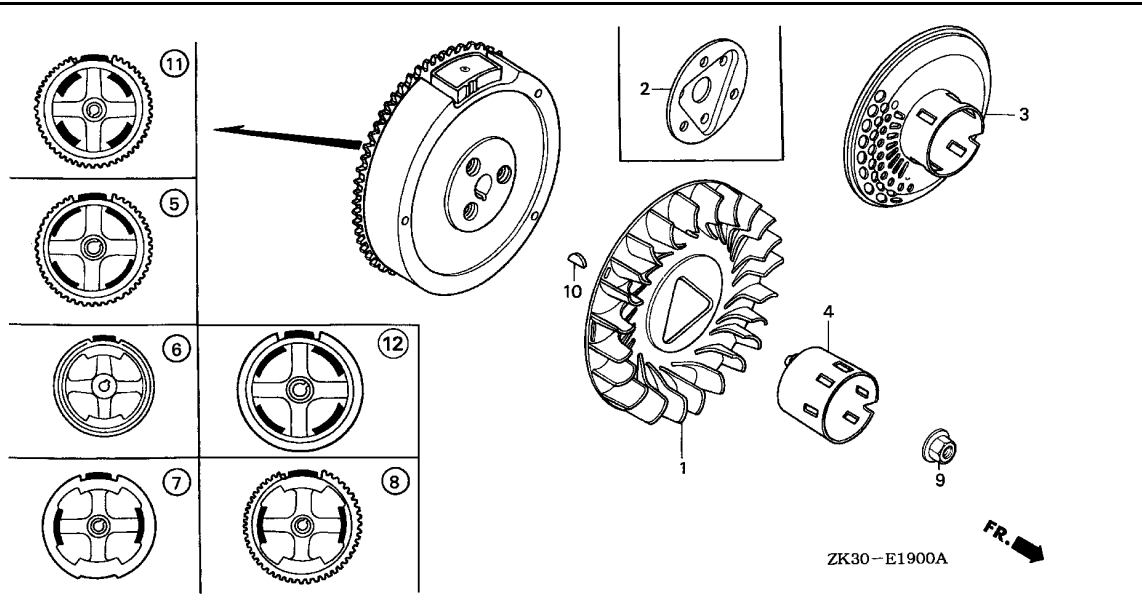

Ref. No.	L.O.N.	(Relative ref. Number) Description	F.R.T.
1	1141G7	FAN, ENGINE COOLING .....	0.2
2	1141H0	PLATE, COOLING FAN SETTING ...	0.2
4		(3)	
5	1121A9	PULLEY, RECOIL STARTER .....	0.2
		(6,7,8,11,12)	
	2161B5	FLYWHEEL .....	0.3



Ref. No.	Part No.	Description	Reqd. QTY			Serial No.	Parts catalogue code
			(1)	(2)	(3)		
1	19511-ZE3-000	FAN, COOLING .....	1	1	1		
2	19512-ZE2-000	PLATE, COOLING FAN SETTING ..	1	-	-	-----	EDS5,LKE,LKE/A,LWD,LWD1,LWD1/A,SDE,ZK1,ZK1/A
3	28450-ZE3-W11	PULLEY COMP., STARTER (SCREEN GRID)	1	-	-	-----	HA,HAQ,HA2,HA2/A,HH,HX,HX2,HX26,HX26/A,LH,LH/A,LHB1,LHB3,LHB3/A,LHB5,LHC,LHE,LHE/A,LHQ4,LHQ4/A,LHW,LJS,LJS/A,LJS1,LSX,LT,LT/A,LX,LX/A,LXE,LXE/A,LXE2,LXE2/A,LXE4,LXE4/A,LXE6,LXE8,LXE8/A,LXQ4,LXQ4/A,LXU,LXU/A,LXZ,LX2,LX2/A,LX26,LX26/A,PX,PX/A,PXA2,PXE8,PXE8/A,QA,QAB2,QAB2/A,QAC2,QAC2/A,QAE,QAE2,QAE2/A,QAE6,QAE6/A,QAG,QAG/A,QAQ,QAQ2,QAQ2/A,QAQ,QA2,QA2/A,QA26,QA26/A,QDW9,QDW9/A,QE,QE/A,QH,QH/A,QHB3,QHB3/A,QHB5,QHC,QHE,QHE/A,QHP1,QHP1/A,QHQ4,QHQ4/A,QH2,QKA4,QKA4/A,QL2,QMEO,QMEO/A,QME8,QME8/A,QMH,QMH/A,QMT2,QMT2/A,QNE,QNE2,QNE2/A,QNE6,QNE9,QNE9/A,QNR2,QNR2/A,QNR6,QNR6/A,QN18,QP,QP/A,QPE2,QWH2,QWH2/A,QX,QX/A,QXB,QXB/A,QXB7,QXB7/A,QXC,QXC/A,QXC4,QXC4/A,QXC6,QXC6/A,QXC9,QXC9/A,QXE,QXE/A,QXEB,QXE2,QXE4,QXE4/A,QXE6,QXE6/A,QXE8,QXE8/A,QXQ4,QXQ4/A,QXU,QXU/A,QX2,SE,SE/A,SH,SH/A,SHB1,SHB3,SHB3/A,SHE,SHEZ,SHQ4,SHQ4/A,SHT,SMEO,SMEO/A,SWX,SWX/A,SX,SX/A,SXB,SXB/A,SXB7,SXB7/A,SXE,SXE/A,SXEB,SXEB/A,SXE2,SXE4,SXE4/A,SXE8,SXE8/A,SXP,SXQ4,SXQ4/A,SXU,SXU/A,VA,VAA,VAAE,VAD2,VAD2/A,VAH1,VAH2,VA2,VA2/A,VDE,VDE2,VDE2/A,VD16,VE,VEB6,VH,VHE,VH12,VH12/A,VH22,VH22/A,VMX,VNG1,VNG2,VSH7,VWA,VWA2,VWE2,VWE2/A,VX,VX/A,VXA,VXB,VXB/A,VXB2,VXB7,VXB7/A,VXE,VXE/A,VXEB,VXEB/A,VXE2,VXE2/A,VXE4,VXE6,VXE7,VXE7/A,VXE8,VXE8/A,VXG,VXK,VXQ4,VXQ4/A,VXU,VXU/A,VXU1,VXU1/A,VX16,VX16/A,VX8,VX8/A
			-	(1)	-		



Ref. No.	Part No.	Description	Reqd. QTY			Serial No.	Parts catalogue code
			(1)	(2)	(3)		
4	28451-ZE3-W01	PULLEY, STARTER .....	1	-	-	-----	BJ, EDE2, EDE2/A, EDK, EDN, EDN2, EDN2/A, EDN5, EDN5/A, EDS, EDS1, EDS1/A, EDS2, EDS2/A, EDS3, EDS4, EDS6, EDS6/A, EDT, EDT/A, EDT1, EDT1/A, EDT2, EDT3, EDT6, EDT6/A, ED6, ED6/A, ED8, ED8/A, ED9, ED9/A, EMT, EMT/A, EN, ENT, ENT/A, ENT2, EN6, EN6/A, ES, ES1, ES1/A, ES2, ES3, ES3/A, ES4, ES4/A, ET, ETS, ETX, HA2, HA2/A, HX26, HX26/A, LH, LH/A, LHB3, LHB3/A, LHE, LHE/A, LHQ4, LHQ4/A, LJ, LJ/A, LJG, LJG/A, LJS, LJS1, LKE, LKE/A, LP, LT, LT/A, LX, LX/A, LXE, LXE/A, LXE2, LXE2/A, LXE4, LXE4/A, LXE8, LXE8/A, LXQ4, LXQ4/A, LXU, LXU/A, LX2, LX2/A, LX26, LX26/A, PKT2, PKT2/A, PKT4, PKT4/A, PKX2, PKX4, PKX4/A, PX, PX/A, PXE8, PXE8/A, QAB2, QAB2/A, QAC2, QAC2/A, QAE, QAE2, QAE2/A, QAE6, QAE6/A, QAG, QAG/A, QAH2, QAH2/A, QAP2, QAP2/A, QA2, QA2/A, QA26, QA26/A, QDW9, QDW9/A, QE, QE/A, QH, QH/A, QHB3, QHB3/A, QHE, QHE/A, QHP1, QHP1/A, QHQ4, QHQ4/A, QKA4, QKA4/A, QME0, QME0/A, QME8, QME8/A, QMH, QMH/A, QMT2, QMT2/A, QMX2, QNE2, QNE2/A, QNE9, QNE9/A, QNR2, QNR2/A, QNR6, QNR6/A, QP, QP/A, QT, QT/A, QTC2, QTC2/A, QWH2, QWH2/A, QX, QX/A, QXB, QXB/A, QXC, QXC/A, QXC4, QXC4/A, QXC6, QXC6/A, QXC9, QXC9/A, QXE, QXE/A, QXE4, QXE4/A, QXE6, QXE6/A, QXE8, QXE8/A, QXQ4, QXQ4/A, QXU, QXU/A, SE, SE/A, SH, SH/A, SHB3, SHB3/A, SHQ4, SHQ4/A, SJ, SJ/A, SJG, SJG/A, SKE, SKE/A, SK2, SK2/A, SME0, SME0/A, SMX2, SMX2/A, STJ, STJ/A, STP, STP/A, STQ, STQ/A, STR, STR/A, SWX, SWX/A, SX, SX/A, SXB, SXB/A, SXE, SXE/A, SXEB, SXEB/A, SXE4, SXE4/A, SXE8, SXE8/A, SXQ4, SXQ4/A, SXU, SXU/A, VAD2, VAD2/A, VAW1, VAW1/A, VA2, VA2/A, VC2, VC2/A, VDE2, VDE2/A, VH12, VH12/A, VH22, VH22/A, VMQ, VMT, VMT/A, VNG, VSH7, VS2, VS3, VS4, VS5, VS6, VS7, VTE2, VVC, VVC2, VVC2/A, VME, VME2, VME2/A, VMS2, VMS2/A, VW12, VW12/A, VX, VX/A, VXB, VXB/A, VXB7, VXE, VXE/A, VXB, VXB/A, VXE8, VXE8/A, VXQ4, VXQ4/A, VXU, VXU/A, VXU1, VXU1/A, VX16, VX16/A, VX8, VX8/A, YJ
5	31100-ZE3-W00	FLYWHEEL COMP. (10A) .....	-	(1)	-	-----	L1, L1/A, P1, P1/A, S1, S1/A
	31100-ZE3-W01	FLYWHEEL COMP. (SEL-4POLE) ..	1	(1)	-	-----	ED6, ED6/A, EN6, EN6/A, LKE/A, LWD, L1, L1/A, QAE, QAE2, QAE2/A, QAE6, QAE6/A, QAPE, QME0, QME0/A, QME8, QME8/A, QNE, QNE2, QNE2/A, QNE6, QNE9, QNE9/A, QPE2, Q1, Q1/A, SME0, SME0/A, S1, S1/A, VNG2, VTE2, V1, ZK1, ZK1/A
	31100-ZE3-W10	FLYWHEEL COMP. (18A) .....	1	-	-	2033705	----- LKE
	31100-ZE3-W20	FLYWHEEL COMP. (SEL-18A) .....	-	(1)	-	2249296	----- L1/A, P1/A, Q1/A, S1/A
	31100-ZE3-W21	.....	-	(1)	-	2249246	----- L1, P1, Q1, S1, V1
	31100-ZE3-W21	.....	1	-	-	-----	LWD1, LWD1/A, QAH2, QAH2/A, QL2, QNR2, QNR2/A, QNR6, QNR6/A, QN18
6	31100-ZE3-700	FLYWHEEL COMP. ....	1	-	-	2374605	----- Ed6
	31100-ZE3-701	.....	-	(1)	-	-----	L1, L1/A, S1, S1/A
	31100-ZE3-701	.....	1	-	-	-----	BJ, EDK, EDT1, EDT1/A, EDT2, EDT3, EDT6, EDT6/A, ED8, ED8/A, ED9, ED9/A, EMT, EMT/A, EN, ES, ES1, ES1/A, ES2, ES3, ES3/A, ET, ETX, HA, HAQ, HA2, HA2/A, HH, HX, HX2, HX26, HX26/A, LH, LH/A, LHB1, LHB3, LHB3/A, LHB5, LHC, LHQ4, LHQ4/A, LHW, LJ, LJ/A, LJG, LJG/A, LJS, LJS/A, LJS1, LP, LSX, LX, LX/A, LXQ4, LXQ4/A, LXU, LXU/A, LXZ, LX2, LX2/A, LX26, LX26/A, PKT2, PKT2/A, PKT4, PKT4/A, PKX2, PKX4, PKX4/A, PX, PX/A, PXA2, QA, QAB2, QAB2/A, QAC2, QAC2/A, QAP, QAP2, QAP2/A, QAQ, QA2, QA2/A, QA26, QA26/A, QDW9, QDW9/A, QE, QE/A, QH, QH/A, QHB3, QHB3/A, QHB5, QHC, QHP1, QHP1/A, QHQ4, QHQ4/A, QH2, QKA4, QKA4/A, QMH, QMH/A, QMT2, QMT2/A, QMX2, QT, QT/A, QTC2, QTC2/A, QWH2, QWH2/A, QX, QX/A, QXB, QXB/A, QXB7, QXB7/A, QXC, QXC/A, QXC4, QXC4/A, QXC6, QXC6/A, QXC9, QXC9/A, QXQ4, QXQ4/A, QXU, QXU/A, QX2, SE, SE/A, SH, SH/A, SHB1, SHB3, SHB3/A, SHQ4, SHQ4/A, SHT, SJ, SJ/A, SJG, SJG/A, SK2, SK2/A, SMX2, SMX2/A, STP, STP/A, STQ, STQ/A, STR, STR/A, SX, SX/A, SXB, SXB/A, SXB7, SXB7/A, SXP, SXQ4, SXQ4/A, SXU, SXU/A, VA, VAA, VAD2, VAD2/A, VAH1, VAW1, VA2, VA2/A, VC2, VC2/A, VDE, VDE2, VDE2/A, VD16, VE, VH, VH12, VH12/A, VMX, VNG, VNG1, VSH7, VS2, VS3, VS4, VMC, VMC2, VMC2/A, VW12, VW12/A, VX, VX/A, VXA, VXB, VXB/A, VXB2, VXB7, VXB7/A, VXX, VXX/VXQ4, VXQ4/A, VXU, VXU/A, VX16, VX16/A, VX8, VX8/A, YJ
7	31100-ZE3-711	FLYWHEEL COMP. (LAMP) .....	-	(1)	1	-----	
			-	(1)	-	-----	



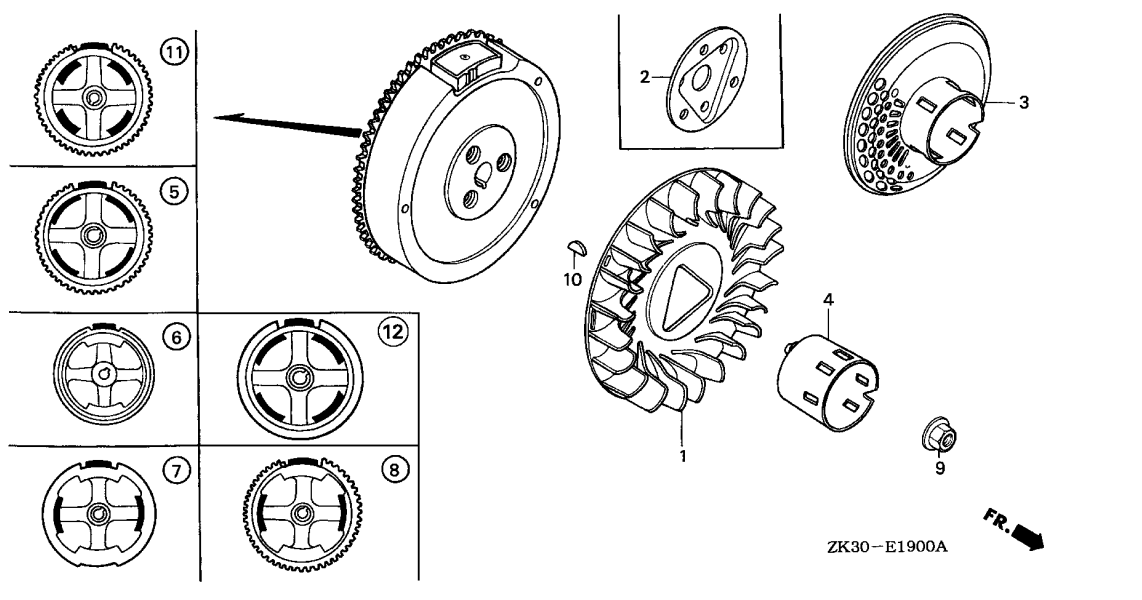

Ref. No.	Part No.	Description	Reqd. QTY			Serial No.	Parts catalogue code
			GX	340K1			
			(1)	(2)	(3)		
(7)	31100-ZE3-712	FLYWHEEL COMP. (LAMP) .....	1	(1)	-	-----	EDN,EDN2,EDN2/A,EDN5,EDN5/A,LT,LT/A,L1,L1/A,QP,QP/A,SWX,SWX/A,S1 S1/A
8	31100-ZE3-721	FLYWHEEL COMP. (SEL-LAMP) ...	-	(1)	-	-----	L1,L1/A,Q1,Q1/A,S1,S1/A
	31100-ZE3-722	.....	1	(1)	-	-----	EDE2,EDE2/A,EDS,EDS1,EDS1/A,EDS2,EDS2/A,EDS3,EDS4,EDS5,EDS6 EDS6/A,EDT,EDT/A,ED7,ENT,ENT/A,ENT2,ES4,ES4/A,ETS,LHE,LHE/A,LXE LXE/A,LXE2,LXE2/A,LXE4,LXE4/A,LXE6,LXE8,LXE8/A,L1,L1/A,PXE8 PXE8/A,P1,P1/A,QHE,QHE/A,QXE,QXE/A,QXEB,QXE2,QXE4,QXE4/A,QXE6 QXE6/A,QXE8,QXE8/A,SDE,SHE,SHEZ,SKE,SKE/A,SME2,STJ,STJ/A,SXE SXE/A,SXEB,SXEB/A,SXE2,SXE4,SXE4/A,SXE8,SXE8/A,S1,S1/A,VAE,VAH2 VEB6,VHE,VH22,VH22/A,VMQ,VMT,VMT/A,VS5,VS6,VS7,VWA,VWA2,VWE,VWE2 VWE2/A,VWS2,VWS2/A,VXE,VXE/A,VXEB,VXEB/A,VXE2,VXE2/A,VXE4,VXE6 VXE7,VXE7/A,VXE8,VXE8/A,VXU1,VXU1/A,V1
9	90201-ZE3-790	NUT, SPECIAL, 16MM .....	1	1	-	-----	2536522 BJ,EDE2,EDN,EDN2,EDS,EDS1,EDS3,EDS5,EDT1,ED6,ED7,ED8,ED9,EN,ES ES1,ES3,ES4,ET,ETS,ETX,HA,HAQ,HA2,HH,HX,HX2,HX26,LH,LHB1,LHB3,LHC LHE,LHQ4,LJ,LJG,LKE,LP,LX,LXE,LXE2,LXE4,LXE6,LXQ4,LXZ,LX2,LX26,L1 PKT2,PX,P1,QA,QAE,QAE2,QAE6,QAP,QAPE,QAP2,QAQ,QA2,QA26,QDW9,QE,QH QHB3,QHC,QHE,QHQ4,QH2,QMEO,QMT2,QNE,QNE2,QNE6,QNE9,QNR2,QNR6,QN18 QP,QPE2,QT,QTC2,QX,QXB,QXC,QXC4,QXC6,QXC9,QXE,QXEB,QXE2,QXE4,QXE6 QXQ4,QX2,Q1,SDE,SE,SH,SHB1,SHB3,SHE,SHEZ,SHQ4,SHT,SJ,SJG,SKZ,SME0 SME2,SMX2,STJ,STP,STQ,SWX, SX, SXB, SXE, SXEB, SXE2, SXE4, SXP, SXQ4, S1 VA, VAA, VAAE, VAD2, VAH1, VAH2, VAW1, VA2, VDE, VDE2, VD16, VE, VEB6, VH, VHE VH12, VH22, VNG, VNG1, VNG2, VWA, VWA2, VWC2, VWE2, VWS2, VW12, VX, VXA, VXB VXB2, VXE, VXEB, VXE2, VXE4, VXE6, VVG, VVQ4, VXU, VXU1, VX16, V1, YJ, ZK1
			-	-	1	-----	1000004

Ref. No.	Part No.	Description	Reqd. QTY			Serial No.	Parts catalogue code
			(1)	(2)	(3)		
(9)	90201-ZE3-V00	NUT, SPECIAL, 16MM .....	1	1	-	2536523	----- BJ,EDE2,EDN,EDN2,EDS,EDS1,EDS3,EDS5,EDT1,ED6,ED7,ED8,ED9,EN,ES ES1,ES3,ES4,ET,ETS,ETX,HA,HAQ,HA2,HH,HX,HX2,HX26,LH,LHB1,LHB3,LHC LHE,LHQ4,LJ,LJG,LKE,LP,LX,LXE,LXE2,LXE4,LXE6,LXQ4,LXZ,LX2,LX26,L1 PKT2,PX,P1,QA,QAE,QAE2,QAE6,QAP,QAPE,QAP2,QAQ,QA2,QA26,QDW9,QE,QH QHB3,QHC,QHE,QHQ4,QH2,QMEO,QMT2,QNE,QNE2,QNE6,QNE9,QNR2,QNR6,QN18 QP,QPE2,QT,QTC2,QX,QXB,QXC,QXC4,QXC6,QXC9,QXE,QXEB,QXE2,QXE4,QXE6 QXQ4,QX2,Q1,SDE,SE,SH,SHB1,SHB3,SHE,SHEZ,SHQ4,SHT,SJ,SJG,SKZ,SME0 SME2,SMX2,STJ,STP,STQ,SWX,SX,SXB,SXE,SXEB,SXE2,SXE4,SXP,SXQ4,S1 VA,VAA,VAE,VAD2,VAH1,VAH2,VAW1,VA2,VDE,VDE2,VD16,VE,VEB6,VH,VHE VH12,VH22,VNG,VNG1,VNG2,VWA,VWA2,VWC2,VWE2,VWS2,VW12,VX,VXA,VXB VXB2,VXE,VXEB,VXE2,VXE4,VXE6,VXG,VXQ4,VXU,VXU1,VX16,V1,YJ,ZK1 -----
			1	1	-	4058429	----- EDK,EDN5/A,EDS1/A,EDS4,EDT1/A,ED8/A,ED9/A,EMT/A,ES1/A,ES3/A,ES4/A LH/A,LHB3/A,LHB5,LHE/A,LJ/A,LJG/A,LJS/A,LJS1,LT/A,LWD,LWD1/A,LX/A LXE/A,L1/A,PX/A,P1/A,QH/A,QHB3/A,QHB5,QHP1/A,QMH/A,QP/A,QT/A,QX/A QXC/A,QXE/A,Q1/A,SH/A,SJ/A,SJG/A,SKE/A,SKZ/A,STJ/A,STP/A,STQ/A STR/A,SX/A,SXE/A,S1/A,VMQ,VMT/A,VS3,VS4,VS5,VS6,VX/A,VXE/A,VXEB/A VXK,VXU/A,VXU1/A -----
			1	-	-	-----	----- EDE2/A,EDN2/A,EDN5,EDS2,EDS2/A,EDS6,EDS6/A,EDT,EDT/A,EDT2,EDT6 EDT6/A,ED6/A,EMT,ENT,ENT/A,ENT2,EN6,EN6/A,HA2/A,HX26/A,LHQ4/A,LHW LJS,LKE/A,LSX,LT,LWD1,LXE2/A,LXE4/A,LXE8,LXE8/A,LXQ4/A,LXU,LXU/A LX2/A,LX26/A,PKT2/A,PKT4,PKT4/A,PKX2,PKX4,PKX4/A,PXA2,PXE8,PXE8/A QAB2,QAB2/A,QAC2,QAC2/A,QAE2/A,QAE6/A,QAG,QAG/A,QA2,QA2/A,QA26/A,QDW9/A,QE/A,QHE/A,QHP1,QHQ4/A,QKA4,QKA4/A,QL2 QMEO/A,QME8,QME8/A,QMH,QMT2/A,QMX2,QNE2/A,QNE9/A,QNR2/A,QNR6/A QTC2/A,QWH2,QWH2/A,QXB/A,QXB7,QXB7/A,QXC4/A,QXC6/A,QXC9/A,QXE4/A QXE6/A,QXE8,QXE8/A,QXQ4/A,QXU,QXU/A,SE/A,SHB3/A,SHQ4/A,SKE,SME0/A SMX2/A,STR,SWX/A,SXB/A,SXB7,SXB7/A,SXEB/A,SXE4/A,SXE8,SXE8/A SXQ4/A,SXU,SXU/A,VAD2/A,VA2/A,VC2,VC2/A,VDE2/A,VH12/A,VH22/A,VMT VMX,VSH7,VTE2,VWC,VWC2/A,VWE,VWE2/A,VWS2/A,VW12/A,VXB/A,VXB7 VXB7/A,VXE2/A,VXE7,VXE7/A,VXE8,VXE8/A,VXQ4/A,VX16/A,VX8,VX8/A ZK1/A -----
	90201-ZE3-790	.....	-	-	1	1000005	-----
			1	1	-	4058430	----- EDK,EDN5/A,EDS1/A,EDS4,EDT1/A,ED8/A,ED9/A,EMT/A,ES1/A,ES3/A,ES4/A LH/A,LHB3/A,LHB5,LHE/A,LJ/A,LJG/A,LJS/A,LJS1,LT/A,LWD,LWD1/A,LX/A LXE/A,L1/A,PX/A,P1/A,QH/A,QHB3/A,QHB5,QHP1/A,QMH/A,QP/A,QT/A,QX/A QXC/A,QXE/A,Q1/A,SH/A,SJ/A,SJG/A,SKE/A,SKZ/A,STJ/A,STP/A,STQ/A STR/A,SX/A,SXE/A,S1/A,VMQ,VMT/A,VS3,VS4,VS5,VS6,VX/A,VXE/A,VXEB/A VXK,VXU/A,VXU1/A -----
10	90741-ZE2-000	KEY, SPECIAL WOODRUFF, 25X18	1	-	-	-----	----- EDT3,ES2,VS2,VS7
11	31100-ZE3-831	FLYWHEEL COMP. (4POLE) (SEL) -	1	-	-	-----	----- 2033704 LKE
12	31100-ZE3-U10	FLYWHEEL COMP. (4POLE) .....	1	-	-	-----	----- QAG,QAG/A



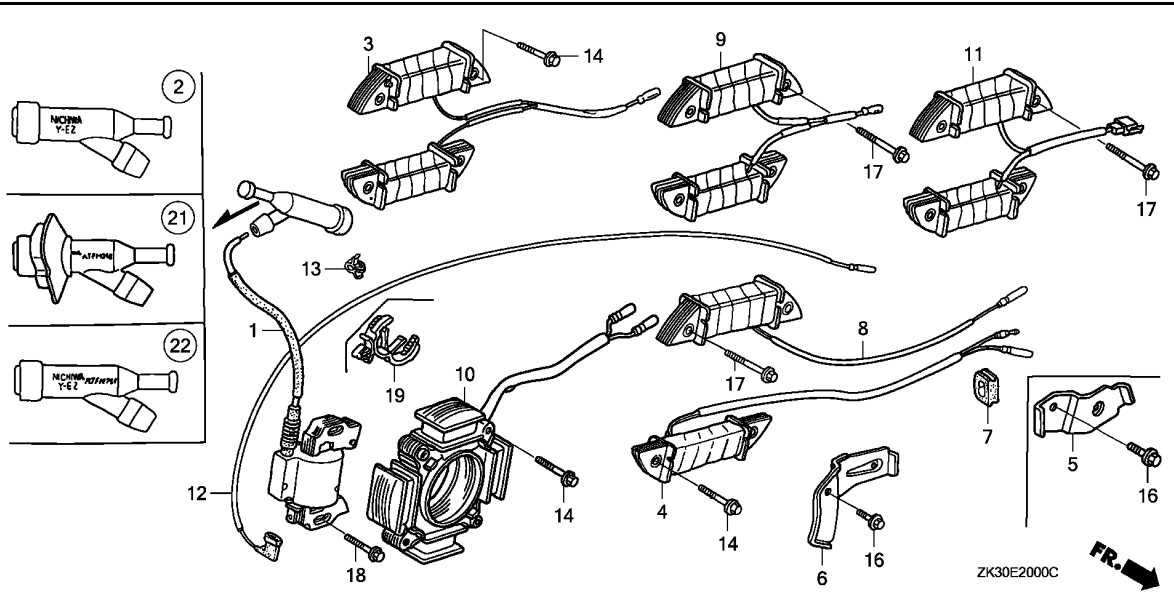

Ref. No.	L.O.N.	(Relative ref. Number) Description	F.R.T.
1	6141A5	COIL, IGNITION(ONE) (21,22)	0.3
2	6141B8	TERMINAL, HIGH TENSION (4)	0.1
3	6141A6	COIL, LAMP (9,11)	0.3
8	6131C3	COIL, CHARGE	0.3
12	6111B3	CORD, STOP SWITCH	0.3

Ref. No.	Part No.	Description	Reqd. QTY			Serial No.	Parts catalogue code
			GX	340K1			
			(1)	(2)	(3)		
1	30500-ZE2-013	COIL ASSY., IGNITION	1	-	-	2286768	EDN,EDS,ED6,ED7,ED8,ED9,ES,ES1,ES3,ES4,ETS,ETX,HH,HX,LH,LHC,LHE,LKE,LP,LX,LXE,LXZ,PX,QE,QH,QHC,QHE,QP,QT,QX,QXB,QXC,QXE,QXEB,SE,SH,SHE,SHEZ,SWX,SX,SXB,SXE,SXEB,VAA,VAE,VE,VH,VHE,VNG,VNG1,VNG2,VX,VXB,VXE,VXEB,VXG,VXU,VXU1
			1	-	-	2288955	HAQ,QAQ,QNE9
			1	-	-	2326583	EN,ET

2

Ref. No.	Part No.	Description	Reqd. QTY			Serial No.	Parts catalogue code
			(1)	(2)	(3)		
(1)	30500-ZF6-W02	COIL ASSY., IGNITION .....	1	1	-	-----	EDE2,EDE2/A,EDN2,EDN2/A,EDN5,EDS2,EDS2/A,EDS3,EDS5,EDS6,EDS6/A,EDT,EDT/A,EDT2,EDT6,EDT6/A,ED6/A,EMT,ENT,ENT/A,EN6,EN6/A,HA2,HA2/A,HX2,HX26,HX26/A,LHB1,LHB3,LHQ4,LHQ4/A,LHW,LKE/A,LSX,LT,LXE2,LXE2/A,LXE4,LXE4/A,LXE6,LXE8,LXE8/A,LXQ4,LXQ4/A,LXU,LXU/A,LX2,LX2/A,LX26,LX26/A,L1,PKT2,PKT2/A,PKT4,PKT4/A,PKX2,PKX4,PKX4/A,PXA2,PXE8,PXE8/A,P1,QAB2,QAB2/A,QAC2,QAC2/A,QAE2,QAE2/A,QAE6,QAE6/A,QAG,QAG/A,QA2,QA2/A,QAH2,QAH2/A,QAP2,QAP2/A,QA2,QA2/A,QA26,QA26/A,QDW9,QDW9/A,QE/A,QHB3,QHE/A,QHP1,QHQ4,QHQ4/A,QH2,QKA4,QKA4/A,QL2,QMEO,QMEO/A,QME8,QME8/A,QMH,QMT2,QMT2/A,QMX2,QNE2,QNE2/A,QNE6,QNE9/A,QNR2,QNR2/A,QNR6,QNR6/A,QPE2,QTC2,QTC2/A,QWH2,QWH2/A,QXB/A,QXC4,QXC4/A,QXC6,QXC6/A,QXC9,QXC9/A,QXE2,QXE4,QXE4/A,QXE6,QXE6/A,QXE8,QXE8/A,QXQ4,QXQ4/A,QXU,QXU/A,QX2,Q1,SE/A,SHB1,SHB3,SHB3/A,SHQ4,SHQ4/A,SHT,SMEO,SMEO/A,SME2,SMX2,SMX2/A,SWX/A,SWX/A,SXEB/A,SXE2,SXE4,SXE4/A,SXE8,SXE8/A,SXQ4,SXQ4/A,SXU,SXU/A,S1,VAD2,VAD2/A,VAW1,VA2,VA2/A,VC2,VC2/A,VDE2,VDE2/A,VD16,VEB6,VH12,VH12/A,VH22,VH22/A,VMT,VMX,VTE2,VWA2,VWC,VWC2,VWC2/A,VWE,VWE2/A,VWS2,VWS2/A,VW12,VW12/A,VXB/A,VXB2,VXE2,VXE2/A,VXE4,VXE6,VXE8,VXE8/A,VXQ4,VXQ4/A,VX16,VX16/A,VX8,VX8/A,V1
			1	1	-	4072596	EDK,EDN5/A,EDS4,ED8/A,ED9/A,EMT/A,ES1/A,ES3/A,ES4/A,LH/A,LHB3/A,LHB5,LHE/A,LJS1,LT/A,LX/A,LXE/A,L1/A,PX/A,P1/A,QH/A,QHB3/A,QHB5,QHP1/A,QMH/A,QP/A,QT/A,QX/A,QXC/A,QXE/A,Q1/A,SH/A,SX/A,SXE/A,S1/A,VMQ,VMT/A,VS3,VS4,VS5,VS6,VX/A,VXE/A,VXEB/A,VXK,VXU/A,VXU1/A
			1	-	-	2286769	EDN,EDS,ED6,ED7,ED8,ED9,ES,ES1,ES3,ES4,ETS,ETX,HH,HX,LH,LHC,LHE,LKE,LP,LX,LXE,LXZ,PX,QE,QH,QHC,QHE,QP,QT,QX,QXB,QXC,QXE,QXEB,SE,SH,SHE,SHEZ,SWX,SX,SXB,SXE,SXEB,VAA,VAEA,VE,VH,VHE,VNG,VNG1,VNG2,VX,VXB,VXE,VXEB,VXG,VXU,VXU1
			1	-	-	2288956	HAQ,QAQ,QNE9
			1	-	-	2326584	EN,ET
	30500-ZF6-W03	.....	1	1	-	4072597	EDK,EDN5/A,EDS4,ED8/A,ED9/A,EMT/A,ES1/A,ES3/A,ES4/A,LH/A,LHB3/A,LHB5,LHE/A,LJS1,LT/A,LX/A,LXE/A,L1/A,PX/A,P1/A,QH/A,QHB3/A,QHB5,QHP1/A,QMH/A,QP/A,QT/A,QX/A,QXC/A,QXE/A,Q1/A,SH/A,SX/A,SXE/A,S1/A,VMQ,VMT/A,VS3,VS4,VS5,VS6,VX/A,VXE/A,VXEB/A,VXK,VXU/A,VXU1/A
			1	-	-	-----	EDT3,ES2,VS2,VS7
2	30600-ZE1-013	TERMINAL ASSY., HIGH TENSION (NICHIAWA Y-EZ)	1	-	-	-----	EN,ES,ES1/A,ES3/A,ES4/A,ET,ETS,ETX,LP,LT,LT/A,QT,QT/A
			1	-	-	2427099	LHB1,SHB1
			1	-	-	2582677	ES1,ES3,ES4
			1	-	-	3032023	EDN5,QHB3
3	31510-ZE2-811	COIL ASSY., LAMP (12V/50W) ..	1	-	-	-----	LT,LT/A,QP,QP/A,SWX,SWX/A
4	31510-ZE1-811	COIL ASSY., LAMP (12V/25W) ..	1	-	-	-----	EDE2,EDE2/A,EDN,EDN2,EDN2/A,EDN5,EDN5/A,ED6,ED6/A,EN6,EN6/A,VTE2
	31510-ZE3-003	.....	1	-	-	-----	EDE2,EDE2/A,EDN,EDN2,EDN2/A,ENT,ENT/A
5	31511-ZE2-W00	CLAMPER, CORD .....	1	-	-	-----	QAH2,QAH2/A,QL2,QNR2,QNR2/A
6	31511-ZE3-000	CLAMPER, CORD .....	1	-	-	-----	EDE2,EDE2/A,EDN,EDN2,EDN2/A,EDN5,EDN5/A,EDS,EDS2,EDS2/A,EDS3,EDS4,EDS5,EDS6,EDS6/A,EDT,EDT/A,ED6,ED6/A,ED7,ENT,ENT/A,EN6,EN6/A,ES4,ES4/A,ETS,LHE,LHE/A,LKE,LKE/A,LT,LT/A,LXE,LXE/A,LXE2,LXE2/A,LXE4,LXE4/A,LXE6,LXE8,LXE8/A,PXE8,PXE8/A,QAE2,QAE2/A,QAE6,QAE6/A,QAG,QAG/A,QHE,QHE/A,QMEO,QMEO/A,QME8,QME8/A,QNE2,QNE2/A,QNE6,QNE9,QNE9/A,QP,QP/A,QPE2,QXE,QXE/A,QXEB,QXE2,QXE4,QXE4/A,QXE6,QXE6/A,QXE8,QXE8/A,SHE,SHEZ,SMEO,SMEO/A,SME2,SWX,SWX/A,SXE,SXE/A,SXEB,SXEB/A,SXE2,SXE4,SXE4/A,SXE8,SXE8/A,VAEA,VEB6,VHE,VH22,VH22/A,VMQ,VMT,VMT/A,VNG2,VS5,VS6,VS7,VTE2,VWA2,VWE,VWE2,VWE2/A,VWS2,VWS2/A,VXE,VXE/A,VXEB,VXEB/A,VXE2,VXE2/A,VXE4,VXE6,VXE8,VXE8/A,VXU1,VXU1/A



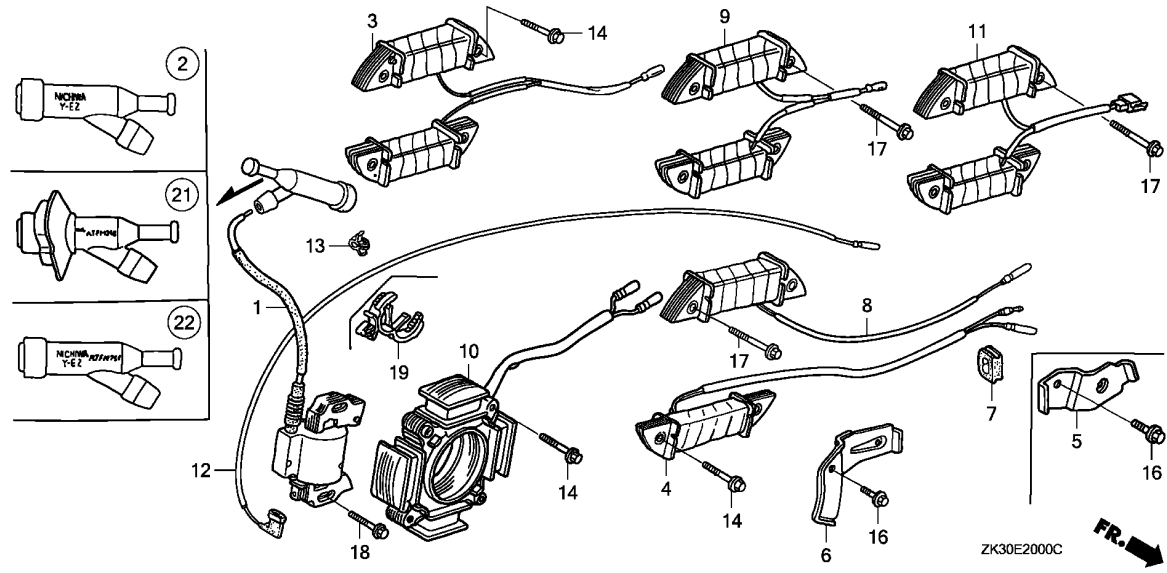

Ref. No.	Part No.	Description	Reqd. QTY			Serial No.	Parts catalogue code
			GX	(1)	(2)		
7	31512-ZE2-000	GROMMET, CORD .....	1	-	-	-----	EDE2,EDE2/A,EDK,EDN,EDN2,EDN2/A,EDN5,EDN5/A,EDS,EDS2,EDS2/A,EDS3,EDS4,EDS5,EDS6,EDS6/A,EDT,EDT/A,EDT2,EDT3,EDT6,EDT6/A,ED6,ED6/A,ED7,ED8,ED8/A,ED9,ED9/A,EMT,EMT/A,EN,ENT,ENT/A,EN6,EN6/A,ES,ES1,ES1/A,ES2,ES3,ES3/A,ES4,ES4/A,ET,ETS,ETX,HAQ,HA2,HA2/A,HH,HX,HX2,HX26,HX26/A,LH,LH/A,LHB1,LHB3,LHB3/A,LHB5,LHC,LHE,LHE/A,LHQ4,LHQ4/A,LHW,LJS1,LKE,LKE/A,LP,LT,LT/A,LX,LX/A,LXE,LXE/A,LXE2,LXE2/A,LXE4,LXE4/A,LXE6,LXE8,LXE8/A,LXQ4,LXQ4/A,LXU,LXU/A,LXZ,LX2,LX2/A,LX26,LX26/A,PKT2,PKT2/A,PKT4,PKT4/A,PKX2,PKX4,PKX4/A,PX,PX/A,PXA2,PXE8,PXE8/A,QAB2,QAB2/A,QAC2,QAC2/A,QAE2,QAE2/A,QAE6,QAE6/A,QAG,QAG/A,QA2,QA2/A,QAP2,QAP2/A,QAQ,QA2,QA2/A,QA26,QA26/A,QDW9,QDW9/A,QE,QE/A,QH,QH/A,QHB3,QHB3/A,QHB5,QHC,QHE,QHE/A,QHP1,QHP1/A,QHQ4,QHQ4/A,QH2,QKA4,QKA4/A,QL2,QMEO,QMEO/A,QME8,QME8/A,QMH,QMH/A,QMT2,QMT2/A,QMX2,QNE2,QNE2/A,QNE6,QNE9,QNE9/A,QNR2,QNR2/A,QNR6,QNR6/A,QP,QP/A,QPE2,QT,QT/A,QTC2,QTC2/A,QWH2,QWH2/A,QX,QX/A,QXB,QXB/A,QXC,QXC/A,QXC4,QXC4/A,QXC6,QXC6/A,QXC9,QXC9/A,QXE,QXE/A,QXEB,QXE2,QXE4,QXE4/A,QXE6,QXE6/A,QXE8,QXE8/A,QXQ4,QXQ4/A,QXU,QXU/A,QX2,SE,SE/A,SH,SH/A,SHB1,SHB3,SHB3/A,SHE,SHEZ,SHQ4,SHQ4/A,SHT,SME0,SME0/A,SME2,SMX2,SMX2/A,SWX,SWX/A,SX,SX/A,SXB,SXB/A,SXE,SXE/A,SXEB,SXEB/A,SXE2,SXE4,SXE4/A,SXE8,SXE8/A,SXQ4,SXQ4/A,SXU,SXU/A,VAA,VAAE,VAD2,VAD2/A,VA2,VA2/A,VC2,VC2/A,VDE2,VDE2/A,VD16,VE,VEB6,VH,VHE,VH12,VH12/A,VH22,VH22/A,VMQ,VMT,VMT/A,VMX,VNG,VNG1,VNG2,VS2,VS3,VS4,VS5,VS6,VS7,VTE2,VMA2,VWC,VWC2,VWC2/A,VWE,VWE2,VWE2/A,VWS2,VWS2/A,VW12,VW12/A,VX,VX/A,VXB,VXB/A,VXB2,VXE,VXE/A,VXEB,VXEB/A,VXE2,VXE2/A,VXE4,VXE4/A,VXE8,VXE8/A,VXG,VXK,VXQ4,VXQ4/A,VXU,VXU/A,VXU1,VXU1/A,VX16,VX16/A,VX8,VX8/A
			-	-	1		

2

Ref. No.	Part No.	Description	Reqd. QTY			Serial No.	Parts catalogue code
			(1)	(2)	(3)		
8	31630-ZE1-003	COIL ASSY., CHARGE (1A) .....	1	-	-	-----	EDS,EDS2,EDS2/A,EDS3,EDS6,EDS6/A,EDT,EDT/A,ED7,ENT,ENT/A,ES4,ETS LHE,LXE,LXE2,LXE2/A,LXE4,LXE4/A,LXE6,LXE8,LXE8/A,PXE8,PXE8/A,QHE QHE/A,QXE,QXEB,QXE2,QXE4,QXE4/A,QXE6,QXE6/A,QXE8,QXE8/A,SHE,SHEZ SME2,SXE,SXEB,SXEB/A,SXE2,SXE4,SXE4/A,SXE8,SXE8/A,VAAE,VEB6,VHE VH22,VH22/A,VMT,VWA2,VME,VME2,VME2/A,VMS2,VMS2/A,VXE,VXEB,VXE2 VXE2/A,VXE4,VXE6,VXE8,VXE8/A,VXU1
			1	-	-	4072612	EDS4,ES4/A,LHE/A,LXE/A,QXE/A,SXE/A,VMQ,VMT/A,VS5,VS6,VXE/A,VXEB/A VXU1/A
	31630-ZE2-841	COIL ASSY., CHARGE (3A) .....	1	-	-	-----	QAE2,QAE2/A,QAE6,QAE6/A,VNG2
	31630-ZE1-013	COIL ASSY., CHARGE (1A) .....	1	-	-	-----	VS7
			1	-	-	4072613	EDS4,ES4/A,LHE/A,LXE/A,QXE/A,SXE/A,VMQ,VMT/A,VS5,VS6,VXE/A,VXEB/A VXU1/A
9	31630-ZE2-E11	COIL ASSY., CHARGE .....	1	-	-	-----	EDS5
10	31630-ZE2-W01	COIL ASSY., CHARGE (12V/18A)	1	-	-	-----	QAH2,QAH2/A,QL2,QNR2,QNR2/A,QNR6,QNR6/A
11	31630-ZE2-861	COIL ASSY., CHARGE (10A) ....	1	-	-	-----	LKE,LKE/A,QAG,QAG/A,QMED,QMED/A,QME8,QME8/A,QNE2,QNE2/A,QNE6,QNE9 QNE9/A,QPE2,SME0,SME0/A
12	36101-ZE2-701	CORD, STOP SWITCH (430MM) ...	1	-	-	-----	EDK,EDN5,EDN5/A,ED7,ED8,ED8/A,ED9,ED9/A,EN,ES,ES1,ES1/A,ES2,ET ETS,ETX,HAQ,HA2,HA2/A,HH,HX,HX2,HX26,HX26/A,LH,LH/A,LHB1,LHB3 LHB3/A,LHB5,LHC,LHE,LHE/A,LHQ4,LHQ4/A,LHW,LJS1,LKE,LKE/A,LP,LT LT/A,LX,LX/A,LXE,LXE/A,LXE2,LXE2/A,LXE4,LXE4/A,LXE6,LXE8,LXE8/A LXQ4,LXQ4/A,LXU,LXU/A,LXZ,LX2,LX2/A,LX26,LX26/A,PKT2,PKT2/A,PKT4 PKT4/A,PKX2,PKX4,PKX4/A,PX,PX/A,PXA2,PXE8,PXE8/A,QAB2,QAB2/A,QAC2 QAC2/A,QAE2,QAE2/A,QAE6,QAE6/A,QAG,QAG/A,QAH2,QAH2/A,QAP2,QAP2/A QAQ,QA2,QA2/A,QA26,QA26/A,QDW9,QDW9/A,QE,QE/A,QH,QH/A,QHB3,QHB3/A QHB5,QHC,QHE,QHE/A,QHP1,QHP1/A,QHQ4,QHQ4/A,QH2,QKA4,QKA4/A,QL2 QMED,QMED/A,QME8,QME8/A,QMH,QMH/A,QMT2,QMT2/A,QMX2,QNE2,QNE2/A QNE6,QNE9,QNE9/A,QNR2,QNR2/A,QNR6,QNR6/A,QP,QP/A,QPE2,QT,QT/A QTC2,QTC2/A,QWH2,QWH2/A,QX,QX/A,QXB,QXB/A,QXC,QXC/A,QXC4,QXC4/A QXC6,QXC6/A,QXC9,QXC9/A,QXE,QXE/A,QXEB,QXE2,QXE4,QXE4/A,QXE6 QXE6/A,QXE8,QXE8/A,QXQ4,QXQ4/A,QXU,QXU/A,QX2,SE,SE/A,SH,SH/A,SHB1 SHB3,SHB3/A,SHE,SHEZ,SHQ4,SHQ4/A,SHT,SME0,SME0/A,SME2,SMX2,SMX2/A SWX,SWX/A,SX,SX/A,SXB,SXB/A,SXE,SXE/A,SXEB,SXEB/A,SXE2,SXE4 SXE4/A,SXE8,SXE8/A,SXQ4,SXQ4/A,SXU,SXU/A,VAE,VAE,VAD2,VAD2/A,VA2 VA2/A,VC2,VC2/A,VDE2,VDE2/A,VD16,VE,VEB6,VH,VHE,VH12,VH12/A,VH22 VH22/A,VMQ,VMT,VMT/A,VMX,VNG,VNG1,VNG2,VWA2,VWC2,VWC2/A,VWE2 VWE2/A,VWS2,VWS2/A,VW12,VW12/A,VX,VX/A,VXB,VXB/A,VXB2,VXE,VXE/A VXEB,VXEB/A,VXE2,VXE2/A,VXE4,VXE6,VXE8,VXE8/A,VXG,VXK,VXQ4,VXQ4/A VXU,VXU/A,VXU1,VXU1/A,VX16,VX16/A,VX8,VX8/A
	36101-ZE3-800	CORD, STOP SWITCH (470MM) ...	-	-	1	-----	EDE2,EDE2/A,EDN,EDN2,EDN2/A,EDS,EDS2,EDS2/A,EDS3,EDS4,EDS5,EDS6 EDS6/A,EDT,EDT/A,EDT2,EDT3,EDT6,EDT6/A,ED6,ED6/A,EMT,EMT/A,ENT ENT/A,EN6,EN6/A,ES3,ES3/A,ES4,ES4/A,VS2,VS3,VS4,VS5,VS6,VS7,VTE2 VWC,VWE
13	36103-ZE1-000	HOLDER, STOP SWITCH CORD .....	1	-	-	-----	EDE2,EDN,EDN2,EDN2/A,ED8,ED8/A,EN,ES,ES3,ES3/A,ET,ETS,HH,LH,LH/A LHB1,LHB3,LHB3/A,LHB5,LHC,LHQ4,LHQ4/A,LHW,LJS1,LP,LT,LT/A,LXE4 LXE4/A,LXE6,PXE8,PXE8/A,QAE6,QAE6/A,QE,QE/A,QH,QH/A,QHB3,QHB3/A QHB5,QHC,QHP1,QHP1/A,QHQ4,QHQ4/A,QMED,QMED/A,QME8,QME8/A,QMH QMH/A,QNE6,QNR6,QNR6/A,QP,QP/A,QT,QT/A,QXE4,QXE4/A,QXE6,QXE6/A,SE SE/A,SH,SH/A,SHB1,SHB3,SHB3/A,SHQ4,SHQ4/A,SME0,SME0/A,SXE4,SXE4/A VE,VEB6,VH,VMQ,VMT,VMT/A,VNG,VS2,VS3,VS4,VTE2,VXE4,VXE6
14	90012-888-000	BOLT, FLANGE, 6X40(CT200) ...	2	-	-	-----	EDE2,EDE2/A,EDN,EDN2,EDN2/A,EDN5,EDN5/A,ED6,ED6/A,ENT,ENT/A,EN6 EN6/A,VTE2
			4	-	-	-----	LT,LT/A,QAH2,QAH2/A,QL2,QNR2,QNR2/A,QNR6,QNR6/A,QP,QP/A,SWX,SWX/A



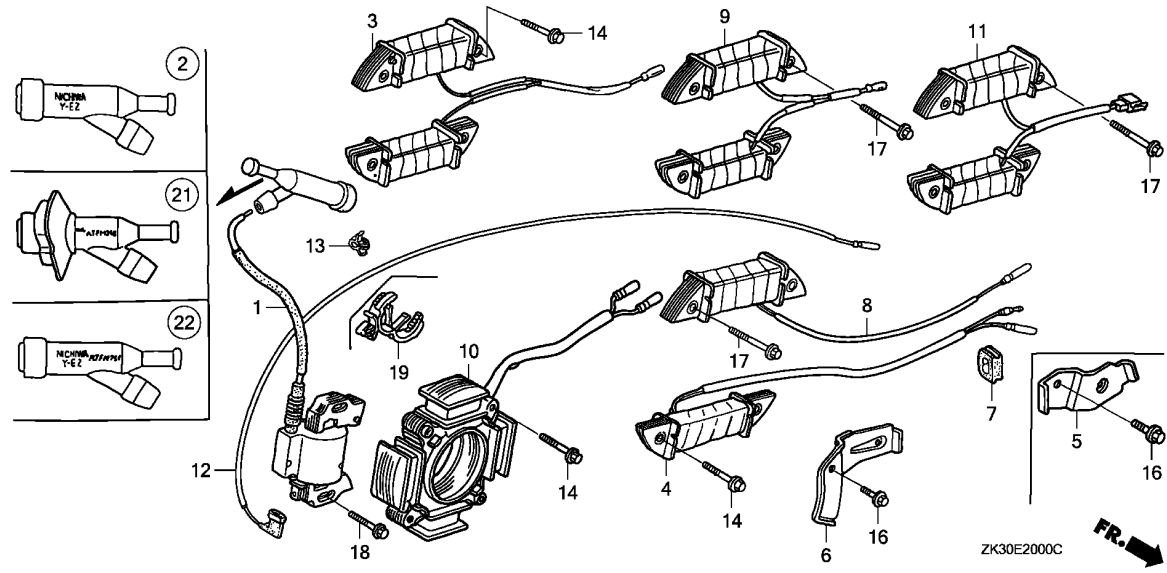

Ref. No.	Part No.	Description	Reqd. QTY			Serial No.	Parts catalogue code
			GX	340K1			
			(1)	(2)	(3)		
16	90013-883-000	BOLT, FLANGE, 6X12(CT200) ...	1	-	-	-----	EDE2,EDE2/A,EDN,EDN2,EDN2/A,EDN5,EDN5/A,EDS,EDS2,EDS2/A,EDS3,EDS4,EDS5,EDS6,EDS6/A,EDT,EDT/A,ED6,ED6/A,ED7,ENT,ENT/A,EN6,EN6/A,ES4,ETS,LHE,LHE/A,LKE,LKE/A,LT,LT/A,LXE,LXE/A,LXE2,LXE2/A,LXE4,LXE4/A,LXE6,LXE8,LXE8/A,PXE8,PXE8/A,QAE2,QAE2/A,QAE6,QAE6/A,QAG,QAG/A,QAH2,QAH2/A,QHE,QHE/A,QL2,QMEO,QMEO/A,QME8,QME8/A,QNE2,QNE2/A,QNE6,QNE9,QNE9/A,QNR2,QNR2/A,QP,QP/A,QPE2,QXE,QXE/A,QXEB,QXE2,QXE4,QXE4/A,QXE6,QXE6/A,QXE8,QXE8/A,SHE,SHEZ,SME0,SME0/A,SME2,SWX,SWX/A,SXE,SXE/A,SXEB,SXEB/A,SXE2,SXE4,SXE4/A,SXE8,SXE8/A,VAAE,VEB6,VHE,VH22,VH22/A,VMQ,VMT,VNG2,VV5,VV6,VV7,VTE2,VWA2,VWE,VWE2,VWE2/A,VWS2,VWS2/A,VXE,VXE/A,VXEB,VXEB/A,VXE2,VXE2/A,VXE4,VXE6,VXE8,VXE8/A,VXU1,VXU1/A
17	90014-ZE6-000	BOLT, FLANGE, 6X35(CT200) ...	2	-	-	-----	EDS,EDS2,EDS2/A,EDS3,EDS4,EDS6,EDS6/A,EDT,EDT/A,ED7,ENT,ENT/A,ES4,ES4/A,ETS,LHE,LHE/A,LXE,LXE/A,LXE2,LXE2/A,LXE4,LXE4/A,LXE6,LXE8,LXE8/A,PXE8,PXE8/A,QHE,QHE/A,QXE,QXE/A,QXEB,QXE2,QXE4,QXE4/A,QXE6,QXE6/A,QXE8,QXE8/A,SHE,SHEZ,SME2,SXE,SXE/A,SXEB,SXEB/A,SXE2,SXE4,SXE4/A,SXE8,SXE8/A,VAAE,VEB6,VHE,VH22,VH22/A,VMQ,VMT,VMT/A,VS5,VS6,VS7,VWA2,VWE,VWE2,VWE2/A,VWS2,VWS2/A,VXE,VXE/A,VXEB,VXEB/A,VXE2,VXE2/A,VXE4,VXE6,VXE8,VXE8/A,VXU1,VXU1/A
	90012-888-000	BOLT, FLANGE, 6X40(CT200) ...	4	-	-	2765247	EDS5
			2	-	-	-----	QAE2,QAE2/A,QAE6,QAE6/A,VNG2
			4	-	-	-----	LKE,LKE/A,QAG,QAG/A,QMEO,QMEO/A,QME8,QME8/A,QNE2,QNE2/A,QNE6,QNE9,QNE9/A,QPE2,SME0,SME0/A
			4	-	-	2765248	EDS5



Ref. No.	Part No.	Description	Reqd. QTY			Serial No.	Parts catalogue code
			(1)	(2)	(3)		
18	90015-883-000	BOLT, FLANGE, 6X28 .....	2	-	-	-----	EDE2,EDE2/A,EDK,EDN,EDN2,EDN2/A,EDN5,EDN5/A,EDS,EDS2,EDS2/A,EDS3,EDS4,EDS5,EDS6,EDS6/A,EDT,EDT/A,EDT2,EDT3,EDT6,EDT6/A,ED6,ED6/A,ED7,ED8,ED8/A,ED9,ED9/A,EMT,EMT/A,EN,ENT,ENT/A,EN6,EN6/A,ES,ES1,ES1/A,ES2,ES3,ES3/A,ES4,ES4/A,ET,ETS,ETX,HAQ,HA2,HA2/A,HH,HX,HX2,HX26,HX26/A,LH,LH/A,LHB1,LHB3,LHB3/A,LHB5,LHC,LHE,LHE/A,LHQ4,LHQ4/A,LHW,LJS1,LKE,LKE/A,LP,LT,LT/A,LX,LX/A,LXE,LXE/A,LXE2,LXE2/A,LXE4,LXE4/A,LXE6,LXE8,LXE8/A,LXQ4,LXQ4/A,LXU,LXU/A,LXZ,LX2,LX2/A,LX26,LX26/A,PKT2,PKT2/A,PKT4,PKT4/A,PKX2,PKX4,PKX4/A,PX,PX/A,PXA2,PXE8,PXE8/A,QAB2,QAB2/A,QAC2,QAC2/A,QAE2,QAE2/A,QAE6,QAE6/A,QAG,QAG/A,QA2,QA2/A,QAP2,QAP2/A,QAQ,QA2,QA2/A,QA26,QA26/A,QDW9,QDW9/A,QE,QE/A,QH,QH/A,QHB3,QHB3/A,QHB5,QHC,QHE,QHE/A,QHP1,QHP1/A,QHQ4,QHQ4/A,QH2,QKA4,QKA4/A,QL2,QMED,QMED/A,QME8,QME8/A,QMH,QMH/A,QMT2,QMT2/A,QMX2,QNE2,QNE2/A,QNE6,QNE9,QNE9/A,QNR2,QNR2/A,QNR6,QNR6/A,QP,QP/A,QPE2,QT,QT/A,QTC2,QTC2/A,QWH2,QWH2/A,QX,QX/A,QXB,QXB/A,QXC,QXC/A,QXC4,QXC4/A,QXC6,QXC6/A,QXC9,QXC9/A,QXE,QXE/A,QXEB,QXE2,QXE4,QXE4/A,QXE6,QXE6/A,QXE8,QXE8/A,QXQ4,QXQ4/A,QXU,QXU/A,QX2,SE,SE/A,SH,SH/A,SHB1,SHB3,SHB3/A,SHE,SHEZ,SHQ4,SHQ4/A,SHT,SMEO,SMEO/A,SME2,SMX2,SMX2/A,SWX,SWX/A,SX,SX/A,SXB,SXB/A,SXE,SXE/A,SXEB,SXEB/A,SXE2,SXE4,SXE4/A,SXE8,SXE8/A,SXQ4,SXQ4/A,SXU,SXU/A,VAA,VAAE,VAD2,VAD2/A,VA2,VA2/A,VC2,VC2/A,VDE2,VDE2/A,VD16,VE,VEB6,VH,VHE,VH12,VH12/A,VH22,VH22/A,VMQ,VMT,VMT/A,VMX,VNG,VNG1,VNG2,VS2,VS3,VS4,VS5,VS6,VS7,VTE2,VVA2,VWC,VWC2,VWC2/A,VWE,VWE2,VWE2/A,VWS2,VWS2/A,VW12,VW12/A,VX,VX/A,VXB,VXB/A,VXB2,VXE,VXE/A,VXEB,VXEB/A,VXE2,VXE2/A,VXE4,VXE6,VXE8,VXE8/A,VXG,VXK,VXQ4,VXQ4/A,VXU,VXU/A,VXU1,VXU1/A,VX16,VX16/A,VX8,VX8/A
19	90684-ZA0-601	CLIP, HARNESS .....	-	2	2	-----	EDN5,EDN5/A,EDT3,EMT,EMT/A,EN6,EN6/A,ES2,PKT4,PKT4/A,PKX2,PKX4,PKX4/A,PXA2,QKA4/A
21	30700-ZB7-013	CAP ASSY., NOISE SUPPRESSOR (NICHIIWA Y-EZ RTFM256)	1	-	-	3105643 -----	QKA4
			1	-	-	-----	EDS5



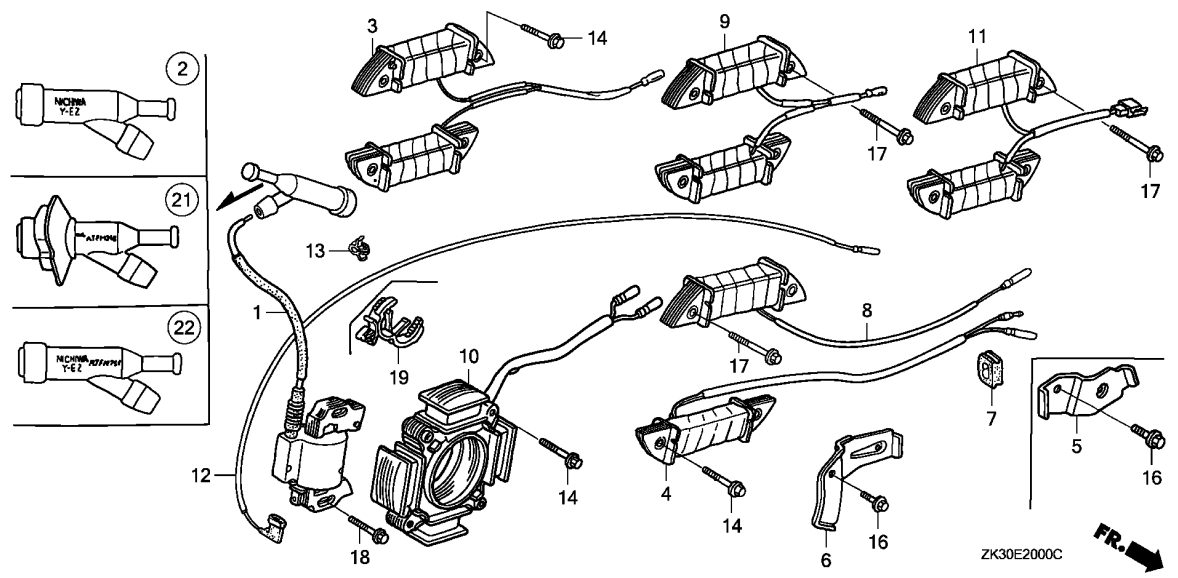

Ref. No.	Part No.	Description	Reqd. QTY GX 340K1 (1) (2) (3)	Serial No.	Parts catalogue code
22	30700-ZE1-013	CAP ASSY., NOISE SUPPRESSOR (NICHIWA Y-EZ RTFM256)	1 - -	-----	EDE2,EDE2/A,EDK,EDN,EDN2,EDN2/A,EDN5/A,EDS,EDS2,EDS2/A,EDS3,EDS4 EDS6,EDS6/A,EDT,EDT/A,EDT2,EDT3,EDT6,EDT6/A,ED6,ED6/A,ED7,ED8 ED8/A,ED9,ED9/A,EMT,EMT/A,ENT,ENT/A,EN6,EN6/A,ES2,HAQ,HA2,HA2/A HH,HX,HX2,HX26,HX26/A,LH,LH/A,LHB3,LHB3/A,LHB5,LHC,LHE,LHE/A,LHQ4 LHQ4/A,LHW,LJS1,LKE,LKE/A,LX,LX/A,LXE,LXE/A,LXE2,LXE2/A,LXE4 LXE4/A,LXE6,LXE8,LXE8/A,LXQ4,LXQ4/A,LXU,LXU/A,LXZ,LX2,LX2/A,LX26 LX26/A,PKT2,PKT2/A,PKT4,PKT4/A,PKX2,PKX4,PKX4/A,PX,PX/A,PXA2,PXE8 PXE8/A,QAB2,QAB2/A,QAC2,QAC2/A,QAE2,QAE2/A,QAE6,QAE6/A,QAG,QAG/A QAH2,QAH2/A,QAP2,QAP2/A,QAQ,QA2,QA2/A,QA26,QA26/A,QDW9,QDW9/A,QE QE/A,QH,QH/A,QHB3/A,QHB5,QHC,QHE,QHE/A,QHP1,QHP1/A,QHQ4,QHQ4/A QH2,QKA4,QKA4/A,QL2,QME0,QME0/A,QME8,QME8/A,QMH,QMH/A,QMT2,QMT2/A QMX2,QNE2,QNE2/A,QNE6,QNE9,QNE9/A,QNR2,QNR2/A,QNR6,QNR6/A,QP,QP/A QPE2,QTC2,QTC2/A,QWH2,QWH2/A,QX,QX/A,QXB,QXB/A,QXC,QXC/A,QXC4 QXC4/A,QXC6,QXC6/A,QXC9,QXC9/A,QXE,QXE/A,QXEB,QXE2,QXE4,QXE4/A QXE6,QXE6/A,QXE8,QXE8/A,QXQ4,QXQ4/A,QXU,QXU/A,QX2,SE,SE/A,SH,SH/A SHB3,SHB3/A,SHE,SHEZ,SHQ4,SHQ4/A,SHT,SME0,SME0/A,SME2,SMX2,SMX2/A SWX,SWX/A,SX,SX/A,SXB,SXB/A,SXE,SXE/A,SXEB,SXEB/A,SXE2,SXE4 SXE4/A,SXE8,SXE8/A,SXQ4,SXQ4/A,SXU,SXU/A,VAA,VAAE,VAD2,VAD2/A,VA2 VA2/A,VC2,VC2/A,VDE2,VDE2/A,VD16,VE,VEB6,VH,VHE,VH12,VH12/A,VH22 VH22/A,VMQ,VMQ,VMT/A,VMX,VNG,VNG1,VNG2,VS2,VS3,VS4,VS5,VS6,VS7 VTE2,VMA2,VWC,VWC2,VWC2/A,VWE,VWE2,VWE2/A,VWS2,VWS2/A,VW12,VW12/A VX,VX/A,VXB,VXB/A,VXB2,VXE,VXE/A,VXEB,VXEB/A,VXE2,VXE2/A,VXE4 VXE6,VXE8,VXE8/A,VXG,VXK,VXQ4,VXQ4/A,VXU,VXU/A,VXU1,VXU1/A,VX16 VX16/A,VX8,VX8/A
	30700-ZE1-013	CAP ASSY., NOISE SUPPRESSOR (NICHIWA Y-EZ RTFM256)	1 - -	3032024	EDN5,QHB3
			1 - -	2427098	LHB1,SHB1
			1 - -	2582676	ES1,ES3,ES4
			- - 1		

2

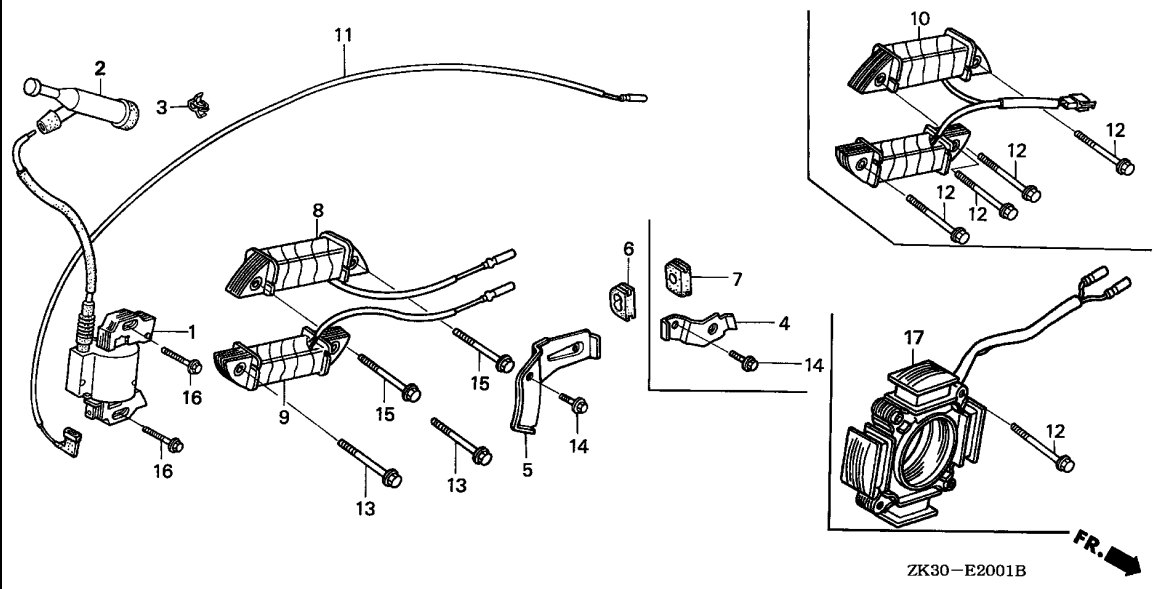

Ref. No.	L.O.N.	(Relative ref. Number) Description	F.R.T.
1	6141A5	COIL, IGNITION(ONE)	0.3
2	6141B8	TERMINAL, HIGH TENSION (9,10,17)	0.1
8	6131C3	COIL, CHARGE	0.3
11	6111B3	CORD, STOP SWITCH	0.3

Ref. No.	Part No.	Description	Reqd. QTY			Serial No.	Parts catalogue code
			GX	(1)	(2)		
1	30500-ZE2-013	COIL ASSY., IGNITION	1	-	-	2286768	HA,QA,QAE,QAP,QAPE,QNE,SXP,VA,VAH1,VAH2,VDE,VWA,VXA
	30500-ZE2-023		1	-	-		QN18
	30500-ZF6-W01		1	-	-	2286769	HA,QA,QAE,QAP,QAPE,QNE,SXP,VA,VAH1,VAH2,VDE,VXA
2	30700-ZE1-013	CAP ASSY., NOISE SUPPRESSOR (NICHIIWA Y-EZ RTFM256)	1	-	-		HA,QA,QAE,QAP,QAPE,QNE,QN18,SXP,VA,VAH1,VAH2,VDE,VWA,VXA
3	30701-883-000	CLIP, HIGH TENSION CORD (8MM)	1	-	-		HA
4	31511-ZE2-W00	CLAMPER, CORD	1	-	-		QN18
5	31511-ZE3-000	CLAMPER, CORD	1	-	-		QAE,QAPE,QNE,VAH2,VWA
6	31512-ZE2-000	GROMMET, CORD	1	-	-		HA,QA,QAE,QAP,QAPE,QNE,SXP,VA,VAH1,VAH2,VDE,VWA,VXA
			1	-	-	2410960	QN18
7	31512-ZG3-000	GROMMET, CORD	1	-	-	2410959	QN18
8	31630-ZE1-003	COIL ASSY., CHARGE (1A)	1	-	-		VAH2,VWA
9	31630-ZE2-841	COIL ASSY., CHARGE (3A)	1	-	-		QAE
10	31630-ZE2-861	COIL ASSY., CHARGE (10A)	1	-	-		QAPE,QNE
11	36101-ZE2-701	CORD, STOP SWITCH (430MM)	1	-	-		HA,QA,QAE,QAP,QAPE,QNE,QN18,SXP,VA,VAH1,VAH2,VDE,VWA,VXA
12	90012-888-000	BOLT, FLANGE, 6X40(CT200)	4	-	-		QAPE,QNE,QN18
13	90012-888-000	BOLT, FLANGE, 6X40(CT200)	2	-	-		QAE
14	90013-883-000	BOLT, FLANGE, 6X12(CT200)	1	-	-		QAE,QAPE,QNE,QN18,VAH2,VWA
15	90014-ZE6-000	BOLT, FLANGE, 6X35(CT200)	2	-	-		VAH2,VWA
16	90015-883-000	BOLT, FLANGE, 6X28	2	-	-		HA,QA,QAE,QAP,QAPE,QNE,QN18,SXP,VA,VAH1,VAH2,VDE,VWA,VXA
17	31630-ZE2-W01	COIL ASSY., CHARGE (12V/18A)	1	-	-		QN18



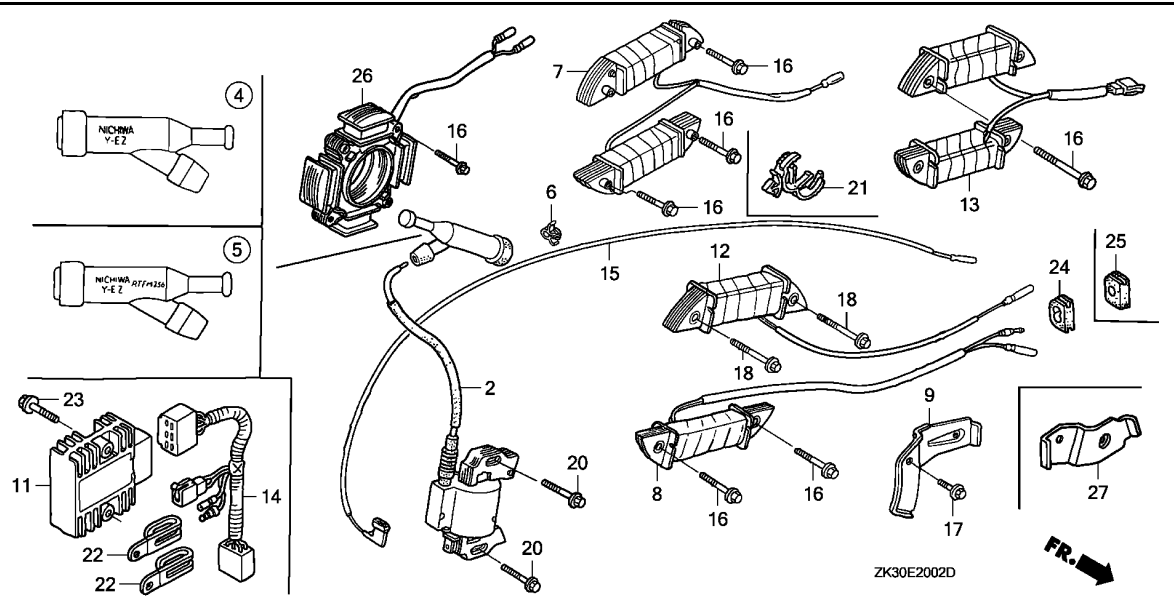

Ref. No.	L.O.N.	(Relative ref. Number) Description	F.R.T.
2	6141A5	COIL, IGNITION(ONE) (4)	0.3
5	6141B8	TERMINAL, HIGH TENSION (8)	0.1
7	6141A6	COIL, LAMP	0.3
11	6131B7	RECTIFIER, REGULATOR (12)	0.2
13	6131C3	COIL, CHARGE	0.3
14	6111E6	HARNESS, REGULATOR RECTIFIER	0.2
15	6111B3	CORD, STOP SWITCH	0.3

Ref. No.	Part No.	Description	Reqd. QTY			Serial No.	Parts catalogue code
			GX	340K1			
			(1)	(2)	(3)		
2	30500-ZE2-013	COIL ASSY., IGNITION	1	-	-	2296924	BJ,EDS1,EDT1,LJ,SJ,STJ,STP,STQ,YJ
	30500-ZE2-023	.....	1	-	-	2287907	L1,P1,Q1,S1,V1
	30500-ZF6-W01	.....	1	(1)	-	2296925	EDS1/A,EDT1/A,LJ/A,LJG,LJG/A,SDE,SJ/A,SJG,SJG/A,SKE,SKE/A,SKZ/A,STJ/A,STP/A,STQ/A,STR,STR/A
	30500-ZF6-W02	.....	1	-	-	2287908	BJ,EDS1,EDT1,LJ,SJ,STJ,STP,STQ,YJ
	30500-ZF6-W03	.....	1	-	-	4072596	LSX,L1/A,P1/A,Q1/A,S1/A
4	30600-ZE1-013	TERMINAL ASSY., HIGH TENSION (NICHIA Y-EZ)	1	-	-	4072597	L1,P1,Q1,S1,V1
		.....	1	-	-		ENT2,LJS,LWD1,QXB7,QXB7/A,SXB7,SXB7/A,VSH7,VXB7,VXB7/A,VXE7
		.....	1	-	-		VXE7/A,ZK1,ZK1/A
		.....	1	-	-		LWD,LWD1/A
		.....	1	-	-		LWD,LWD1/A
5	30700-ZE1-013	CAP ASSY., NOISE SUPPRESSOR (NICHIA Y-EZ RTFM256)	1	-	-	3032023	BJ,LSX,LWD,STJ,STJ/A,YJ
		.....	1	-	-		LJ,LJG,SDE,SJ,SJG,SKE,SKZ,STR
		.....	1	(1)	-		
6	30701-883-000	CLIP, HIGH TENSION CORD (8MM)	-	(1)	-		
	36103-ZE1-000	HOLDER, STOP SWITCH CORD	1	-	-		LJS
		.....	-	(1)	-		
7	31510-ZE2-811	COIL ASSY., LAMP (12V/50W)	-	(1)	-		
8	31510-ZE3-003	COIL ASSY., LAMP (12V/25W)	1	-	-		ENT2,SDE
		.....	-	(1)	-		
	31510-ZE3-811	COIL ASSY., LAMP (6V/25W)	-	(1)	-		

2

Ref. No.	Part No.	Description	Reqd. QTY			Serial No.	Parts catalogue code
			(1)	(2)	(3)		
9	31511-ZE3-000	CLAMPER, CORD .....	1	-	-	-----	EDS1,EDS1/A,ENT2,LWD,SDE,SKE,SKE/A,STJ,STJ/A,VXE7,VXE7/A,ZK1 ZK1/A
11	31600-890-951 31600-ZE2-861	RECTIFIER ASSY., REGULATOR .. RECTIFIER ASSY., REGULATOR (10A)	1	(1)	-	-----	2249295 L1,P1,Q1,S1,V1 2355211 ZK1
12	31630-ZE1-003 31630-ZE1-013 31630-ZE2-841	COIL ASSY., CHARGE (1A) ..... ..... COIL ASSY., CHARGE (3A) .....	1 1 1	(1) (1) (1)	-	-----	ZK1/A ZK1 2355212 EDS1,ENT2,L1,P1,Q1,Q1/A,SDE,SKE,STJ,S1,VXE7,VXE7/A,V1 4072612 EDS1/A,L1/A,P1/A,SKE/A,STJ/A,S1/A 4072613 EDS1/A,L1/A,P1/A,SKE/A,STJ/A,S1/A
13	31630-ZE2-861	COIL ASSY., CHARGE (10A) ....	1	-	-	-----	LWD,ZK1,ZK1/A
14	32100-ZE3-L60	HARNESS ASSY., ENGINE .....	1	-	-	-----	ZK1,ZK1/A
15	36101-ZE2-701	CORD, STOP SWITCH (430MM) ...	1	-	-	-----	BJ,LJ,LJ/A,LJG,LJG/A,LJS,LJS/A,LSX,LWD,LWD1,LWD1/A,QXB7,QXB7/A SDE,SJ,SJ/A,SJG,SJG/A,SKE,SKE/A,SKZ,SKZ/A,STJ,STJ/A,STP,STP/A,STQ STQ/A,STR,STR/A,SXB7,SXB7/A,VSH7,VXB7,VXB7/A,VXE7,VXE7/A,YJ,ZK1 ZK1/A
	36101-ZE3-800	CORD, STOP SWITCH (470MM) ...	1	(1)	-	-----	EDS1,EDS1/A,EDT1,EDT1/A,ENT2
16	90012-888-000	BOLT, FLANGE, 6X40(CT200) ...	N	-	-	-----	ENT2,LWD,LWD1,LWD1/A,SDE,ZK1,ZK1/A
17	90013-883-000	BOLT, FLANGE, 6X12(CT200) ...	1	(N)	-	-----	EDS1,EDS1/A,ENT2,LWD,LWD1,LWD1/A,SDE,SKE,SKE/A,STJ,STJ/A,VXE7 VXE7/A,ZK1,ZK1/A
18	90014-ZE6-000	BOLT, FLANGE, 6X35(CT200) ...	2	(1)	-	-----	EDS1,EDS1/A,ENT2,SDE,SKE,SKE/A,STJ,STJ/A,VXE7,VXE7/A
20	90015-883-000	BOLT, FLANGE, 6X28 .....	2	(2)	-	-----	BJ,EDS1,EDS1/A,EDT1,EDT1/A,ENT2,LJ,LJ/A,LJG,LJG/A,LJS,LSX,LWD LWD1,LWD1/A,QXB7,QXB7/A,SDE,SJ,SJ/A,SJG,SJG/A,SKE,SKE/A,SKZ,SKZ/A STJ,STJ/A,STP,STP/A,STQ,STQ/A,STR,STR/A,SXB7,SXB7/A,VSH7,VXB7 VXB7/A,VXE7,VXE7/A,YJ,ZK1,ZK1/A
21	90684-ZA0-601	CLIP, HARNESS .....	1	(2)	-	-----	EDT1,EDT1/A,LSX,QXB7,QXB7/A,SKZ,SKZ/A,SXB7,SXB7/A,VSH7,VXB7 VXB7/A
22	91406-166-000	CLIP, WIRE .....	2	-	-	-----	ZK1,ZK1/A
23	95701-06025-00	BOLT, FLANGE, 6X25 .....	2	-	-	-----	ZK1,ZK1/A
24	31512-ZE2-000	GROMMET, CORD .....	1	-	-	-----	BJ,EDS1,EDS1/A,EDT1,EDT1/A,ENT2,LJ,LJ/A,LJG,LJG/A,LJS,LSX,LWD LWD1,LWD1/A,QXB7,QXB7/A,SDE,SJ,SJ/A,SJG,SJG/A,SKE,SKE/A,SKZ,SKZ/A STJ,STJ/A,STP,STP/A,STQ,STQ/A,STR,STR/A,SXB7,SXB7/A,VSH7,VXB7 VXB7/A,VXE7,VXE7/A,YJ,ZK1,ZK1/A
25	31512-ZG3-000	GROMMET, CORD .....	-	(1)	-	-----	L1/A,P1/A,Q1/A,S1/A
			-	(1)	-	-----	2249296 L1,P1,Q1,S1,V1
26	31630-ZE2-W01	COIL ASSY., CHARGE (12V/18A)	1	(1)	-	-----	LWD1,LWD1/A
27	31511-ZE2-W00	CLAMPER, CORD .....	1	(1)	-	-----	LWD1,LWD1/A,L1/A,P1/A,Q1/A,S1/A
			-	(1)	-	-----	2249296 L1,P1,Q1,S1,V1



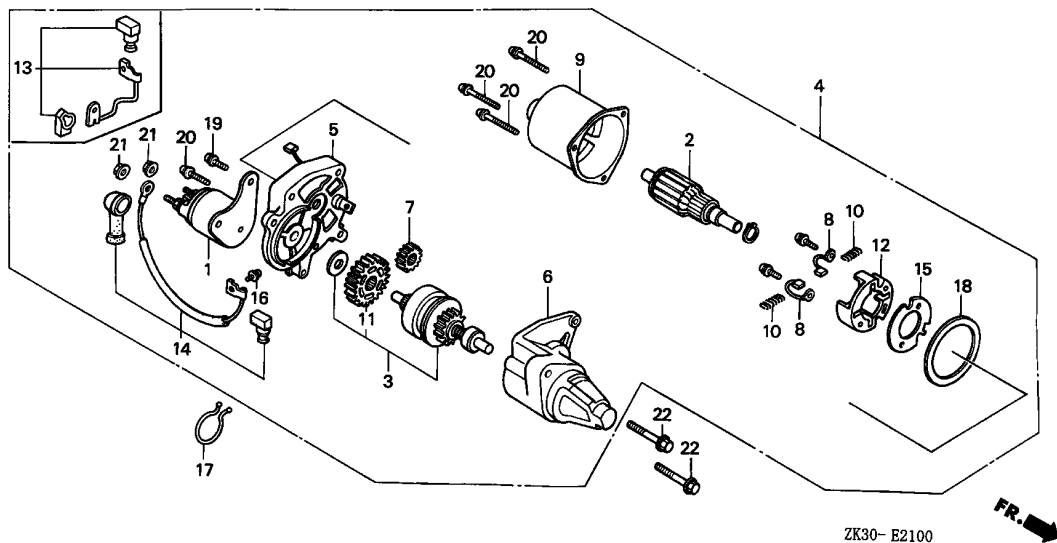

Ref. No.	L.O.N.	(Relative ref. Number) Description	F.R.T.
1	6121E5	CONTACTOR, STARTER .....	0.2
2	6121A0	ARMATURE, STARTER .....	0.4
3		(11)	
	6121B0	CLUTCH, OVERRUNNING .....	0.4
4	6121D5	MOTOR, STARTER .....	0.2
5	6121C3	BRACKET, STARTER :CENTER .....	0.4
6	6121D2	BRACKET, STARTER :FRONT .....	0.3
7	6121B2	GEAR SET, STARTER PINION .....	0.4
8	6121A9	BRUSH, STARTER .....	0.4
9	6121D1	YOKE, STARTER .....	0.4
12	6121B6	HOLDER, STARTER BRUSH .....	0.4
13	6121D0	WIRE, WATER COVER .....	0.1

Ref. No.	Part No.	Description	Reqd. QTY			Serial No.	Parts catalogue code
			GX	(1)	(2)		
1	31204-ZA0-003	CONTACTOR ASSY. ....	1	-	-	-----	EDE2,EDE2/A,EDS,EDS1,EDS1/A,EDS2,EDS2/A,EDS3,EDS4,EDS5,EDS6 EDS6/A,EDT,EDT/A,ED7,ENT,ENT/A,ENT2,ES4,ES4/A,ETS,LHE,LHE/A,LKE LKE/A,LWD,LXE,LXE/A,LXE2,LXE2/A,LXE4,LXE4/A,LXE6,LXE8,LXE8/A,PXE8 PXE8/A,QAE,QAE2,QAE2/A,QAE6,QAE6/A,QAPE,QHE,QHE/A,QL2,QMEO,QMEO/A QME8,QME8/A,QNE,QNE2,QNE2/A,QNE6,QNE9,QNE9/A,QNR2,QNR2/A,QNR6 QNR6/A,QN18,QPE2,QXE,QXE/A,QXEB,QXE2,QXE4,QXE4/A,QXE6,QXE6/A,QXE8 QXE8/A,SDE,SHE,SHEZ,SKE,SKE/A,SME0,SME0/A,SME2,STJ,STJ/A,SXE SXE/A,SXEB,SXEB/A,SXE2,SXE4,SXE4/A,SXE8,SXE8/A,VAAE,VAH2,VEB6,VHE VH22,VH22/A,VMQ,VMT,VMT/A,VNG2,VS5,VS6,VS7,VVA,VVA2,VWE,VWE2 VWE2/A,VWS2,VWS2/A,VXE,VXE/A,VXEB,VXEB/A,VXE2,VXE2/A,VXE4,VXE6 VXE7,VXE7/A,VXE8,VXE8/A,VXU1,VXU1/A,ZK1,ZK1/A
2	31206-ZE3-003	ARMATURE COMP. ....	1	(1)	-	-----	EDE2,EDE2/A,EDS,EDS1,EDS1/A,EDS2,EDS2/A,EDS3,EDS4,EDS5,EDS6 EDS6/A,EDT,EDT/A,ED7,ENT,ENT/A,ENT2,ES4,ES4/A,ETS,LHE,LHE/A,LKE LKE/A,LWD,LWD1,LWD1/A,LXE,LXE/A,LXE2,LXE2/A,LXE4,LXE4/A,LXE6,LXE8 LXE8/A,PXE8,PXE8/A,QAE,QAE2,QAE2/A,QAE6,QAE6/A,QAPE,QHE,QHE/A,QL2 QMEO,QMEO/A,QME8,QME8/A,QNE,QNE2,QNE2/A,QNE6,QNE9,QNE9/A,QNR2 QNR2/A,QNR6,QNR6/A,QN18,QPE2,QXE,QXE/A,QXEB,QXE2,QXE4,QXE4/A,QXE6 QXE6/A,QXE8,QXE8/A,SDE,SHE,SHEZ,SKE,SKE/A,SME0,SME0/A,SME2,STJ STJ/A,SXE,SXE/A,SXEB,SXEB/A,SXE2,SXE4,SXE4/A,SXE8,SXE8/A,VAAE VAH2,VEB6,VHE,VH22,VH22/A,VMQ,VMT,VMT/A,VNG2,VS5,VS6,VS7,VVA,VVA2 VWE,VWE2,VWE2/A,VWS2,VWS2/A,VXE,VXE/A,VXEB,VXEB/A,VXE2,VXE2/A VXE4,VXE6,VXE7,VXE7/A,VXE8,VXE8/A,VXU1,VXU1/A,ZK1,ZK1/A
			-	(1)	-	-----	

Ref. No.	Part No.	Description	Reqd. QTY			Serial No.	Parts catalogue code
			(1)	(2)	(3)		
3	31207-ZE3-003	CLUTCH COMP., OVERRUNNING ...	1	-	-		EDE2,EDE2/A,EDS,EDS1,EDS1/A,EDS2,EDS2/A,EDS3,EDS4,EDS5,EDS6 EDS6/A,EDT,EDT/A,ED7,ENT,ENT/A,ENT2,ES4,ES4/A,ETS,LHE,LHE/A,LKE LKE/A,LWD,LWD1,LWD1/A,LXE,LXE/A,LXE2,LXE2/A,LXE4,LXE4/A,LXE6,LXE8 LXE8/A,PXE8,PXE8/A,QAE,QAE2,QAE2/A,QAE6,QAE6/A,QAPE,QHE,QHE/A,QL2 QME0,QME0/A,QME8,QME8/A,QNE,QNE2,QNE2/A,QNE6,QNE9,QNE9/A,QNR2 QNR2/A,QNR6,QNR6/A,QN18,QPE2,QXE,QXE/A,QXEB,QXE2,QXE4,QXE4/A,QXE6 QXE6/A,QXE8,QXE8/A,SDE,SHE,SHEZ,SKE,SKE/A,SME0,SME0/A,SME2,STJ STJ/A,SXE,SXE/A,SXEB,SXEB/A,SXE2,SXE4,SXE4/A,SXE8,SXE8/A,VAAE VAH2,VEB6,VHE,VH22,VH22/A,VMQ,VMT,VMT/A,VNG2,VS5,VS6,VS7,VWA,VWA2 VWE,VWE2,VWE2/A,VWS2,VWS2/A,VXE,VXE/A,VXEB,VXEB/A,VXE2,VXE2/A VXE4,VXE6,VXE7,VXE7/A,VXE8,VXE8/A,VXU1,VXU1/A,ZK1,ZK1/A
4	31210-ZB8-013 31210-ZE3-013	MOTOR UNIT, STARTER .....	1 1	(1) (1)	-		EDS5 EDE2,EDE2/A,EDS,EDS1,EDS2,EDS2/A,EDS3,EDS6,EDS6/A,EDT,EDT/A,ED7 ENT,ENT/A,ENT2,ES4,ETS,LHE,LHE/A,LKE,LKE/A,LXE,LXE2,LXE2/A,LXE4 LXE4/A,LXE6,LXE8,LXE8/A,L1,PXE8,PXE8/A,P1,QAE,QAE2,QAE2/A,QAE6 QAE6/A,QAPE,QHE,QHE/A,QL2,QME0,QME0/A,QME8,QME8/A,QNE,QNE2,QNE2/A QNE6,QNE9,QNE9/A,QNR2,QNR2/A,QNR6,QNR6/A,QN18,QPE2,QXE,QXE2 QXE4,QXE4/A,QXE6,QXE6/A,QXE8,QXE8/A,Q1,SDE,SHE,SHEZ,SKE,SME0 SME0/A,SME2,STJ,SXE,SXEB,SXEB/A,SXE2,SXE4,SXE4/A,SXE8,SXE8/A,S1 VAAE,VAH2,VEB6,VHE,VH22,VH22/A,VMT,VNG2,VWA,VWA2,VWE,VWE2,VWE2/A VWS2,VWS2/A,VXE,VXEB,VXEB/A,VXE2,VXE2/A,VXE4,VXE6,VXE7,VXE7/A VXE8,VXE8/A,VXU1,VXU1/A,V1,ZK1,ZK1/A
	31210-ZE3-A11 31210-ZE3-023	..... .....	1 1	- (1)	-	4074650 4074651	EDS1/A,EDS4,ES4/A,LWD,LXE/A,L1/A,P1/A,QXE/A,Q1/A,SKE/A,STJ/A SXE/A,S1/A,VMQ,VMT/A,VS5,VS6,VXE/A LWD1,LWD1/A EDS1/A,EDS4,ES4/A,LWD,LXE/A,L1/A,P1/A,QXE/A,Q1/A,SKE/A,STJ/A SXE/A,S1/A,VMQ,VMT/A,VS5,VS6,VXE/A
5	31211-ZE2-003	BRACKET, CENTER .....	1	-	-		VS7 EDE2,EDE2/A,EDS,EDS1,EDS1/A,EDS2,EDS2/A,EDS3,EDS4,EDS5,EDS6 EDS6/A,EDT,EDT/A,ED7,ENT,ENT/A,ENT2,ES4,ES4/A,ETS,LHE,LHE/A,LKE LKE/A,LWD,LWD1,LWD1/A,LXE,LXE/A,LXE2,LXE2/A,LXE4,LXE4/A,LXE6,LXE8 LXE8/A,PXE8,PXE8/A,QAE,QAE2,QAE2/A,QAE6,QAE6/A,QAPE,QHE,QHE/A,QL2 QME0,QME0/A,QME8,QME8/A,QNE,QNE2,QNE2/A,QNE6,QNE9,QNE9/A,QNR2 QNR2/A,QNR6,QNR6/A,QN18,QPE2,QXE,QXE/A,QXEB,QXE2,QXE4,QXE4/A,QXE6 QXE6/A,QXE8,QXE8/A,SDE,SHE,SHEZ,SKE,SKE/A,SME0,SME0/A,SME2,STJ STJ/A,SXE,SXE/A,SXEB,SXEB/A,SXE2,SXE4,SXE4/A,SXE8,SXE8/A,VAAE VAH2,VEB6,VHE,VH22,VH22/A,VMQ,VMT,VMT/A,VNG2,VS5,VS6,VS7,VWA,VWA2 VWE,VWE2,VWE2/A,VWS2,VWS2/A,VXE,VXE/A,VXEB,VXEB/A,VXE2,VXE2/A VXE4,VXE6,VXE7,VXE7/A,VXE8,VXE8/A,VXU1,VXU1/A,ZK1,ZK1/A
			-	(1)	-		
6	31212-ZE3-003	BRACKET, FR. ....	1	-	-		EDE2,EDE2/A,EDS,EDS1,EDS1/A,EDS2,EDS2/A,EDS3,EDS4,EDS5,EDS6 EDS6/A,EDT,EDT/A,ED7,ENT,ENT/A,ENT2,ES4,ES4/A,ETS,LHE,LHE/A,LKE LKE/A,LWD,LWD1,LWD1/A,LXE,LXE/A,LXE2,LXE2/A,LXE4,LXE4/A,LXE6,LXE8 LXE8/A,PXE8,PXE8/A,QAE,QAE2,QAE2/A,QAE6,QAE6/A,QAPE,QHE,QHE/A,QL2 QME0,QME0/A,QME8,QME8/A,QNE,QNE2,QNE2/A,QNE6,QNE9,QNE9/A,QNR2 QNR2/A,QNR6,QNR6/A,QN18,QPE2,QXE,QXE/A,QXEB,QXE2,QXE4,QXE4/A,QXE6 QXE6/A,QXE8,QXE8/A,SDE,SHE,SHEZ,SKE,SKE/A,SME0,SME0/A,SME2,STJ STJ/A,SXE,SXE/A,SXEB,SXEB/A,SXE2,SXE4,SXE4/A,SXE8,SXE8/A,VAAE VAH2,VEB6,VHE,VH22,VH22/A,VMQ,VMT,VMT/A,VNG2,VS5,VS6,VS7,VWA,VWA2 VWE,VWE2,VWE2/A,VWS2,VWS2/A,VXE,VXE/A,VXEB,VXEB/A,VXE2,VXE2/A VXE4,VXE6,VXE7,VXE7/A,VXE8,VXE8/A,VXU1,VXU1/A,ZK1,ZK1/A
			-	(1)	-		



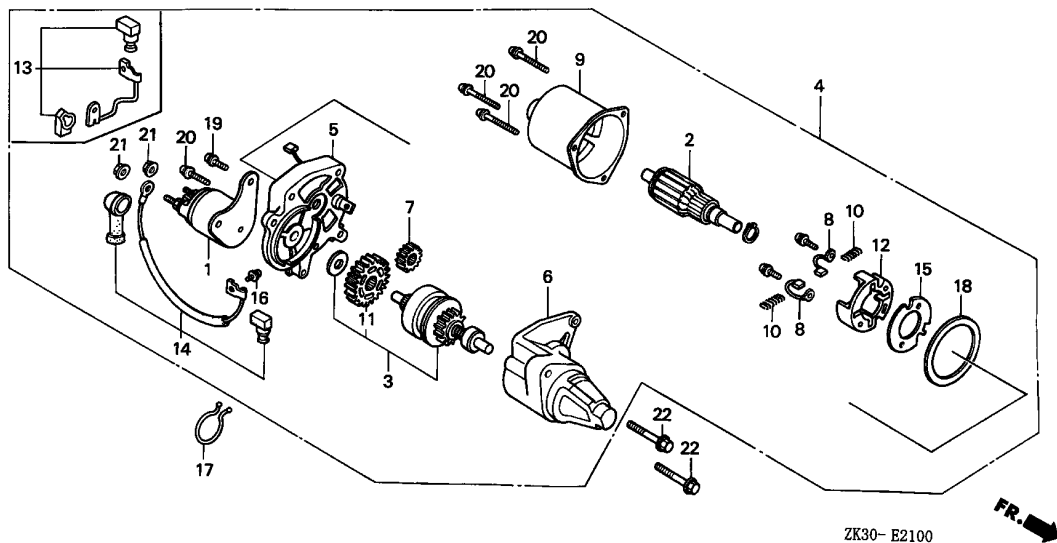

Ref. No.	Part No.	Description	Reqd. QTY			Serial No.	Parts catalogue code
			GX	(1)	(2)		
7	31213-ZE2-003	GEAR, DRIVE PINION .....	1	-	-	-----	EDE2,EDE2/A,EDS,EDS1,EDS1/A,EDS2,EDS2/A,EDS3,EDS4,EDS5,EDS6 EDS6/A,EDT,EDT/A,ED7,ENT,ENT/A,ENT2,ES4,ES4/A,ETS,LHE,LHE/A,LKE LKE/A,LWD,LWD1,LWD1/A,LXE,LXE/A,LXE2,LXE2/A,LXE4,LXE4/A,LXE6,LXE8 LXE8/A,PXE8,PXE8/A,QAE,QAE2,QAE2/A,QAE6,QAE6/A,QAPE,QHE,QHE/A,QL2 QME0,QME0/A,QME8,QME8/A,QNE,QNE2,QNE2/A,QNE6,QNE9,QNE9/A,QNR2 QNR2/A,QNR6,QNR6/A,QN18,QPE2,QXE,QXE/A,QXEB,QXE2,QXE4,QXE4/A,QXE6 QXE6/A,QXE8,QXE8/A,SDE,SHE,SHEZ,SKE,SKE/A,SME0,SME0/A,SME2,STJ STJ/A,SXE,SXE/A,SXEB,SXEB/A,SXE2,SXE4,SXE4/A,SXE8,SXE8/A,VAAE VAH2,VEB6,VHE,VH22,VH22/A,VMQ,VMT,VMT/A,VNG2,VS5,VS6,VS7,VWA,VWA2 VWE,VWE2,VWE2/A,VWS2,VWS2/A,VXE,VXE/A,VXEB,VXEB/A,VXE2,VXE2/A VXE4,VXE6,VXE7,VXE7/A,VXE8,VXE8/A,VXU1,VXU1/A,ZK1,ZK1/A
8	31215-ZE2-003	BRUSH .....	2	(1)	-	-----	EDE2,EDE2/A,EDS,EDS1,EDS1/A,EDS2,EDS2/A,EDS3,EDS4,EDS5,EDS6 EDS6/A,EDT,EDT/A,ED7,ENT,ENT/A,ENT2,ES4,ES4/A,ETS,LHE,LHE/A,LKE LKE/A,LWD,LWD1,LWD1/A,LXE,LXE/A,LXE2,LXE2/A,LXE4,LXE4/A,LXE6,LXE8 LXE8/A,PXE8,PXE8/A,QAE,QAE2,QAE2/A,QAE6,QAE6/A,QAPE,QHE,QHE/A,QL2 QME0,QME0/A,QME8,QME8/A,QNE,QNE2,QNE2/A,QNE6,QNE9,QNE9/A,QNR2 QNR2/A,QNR6,QNR6/A,QN18,QPE2,QXE,QXE/A,QXEB,QXE2,QXE4,QXE4/A,QXE6 QXE6/A,QXE8,QXE8/A,SDE,SHE,SHEZ,SKE,SKE/A,SME0,SME0/A,SME2,STJ STJ/A,SXE,SXE/A,SXEB,SXEB/A,SXE2,SXE4,SXE4/A,SXE8,SXE8/A,VAAE VAH2,VEB6,VHE,VH22,VH22/A,VMQ,VMT,VMT/A,VNG2,VS5,VS6,VS7,VWA,VWA2 VWE,VWE2,VWE2/A,VWS2,VWS2/A,VXE,VXE/A,VXEB,VXEB/A,VXE2,VXE2/A VXE4,VXE6,VXE7,VXE7/A,VXE8,VXE8/A,VXU1,VXU1/A,ZK1,ZK1/A
			-	(2)	-	-----	



Ref. No.	Part No.	Description	Reqd. QTY			Serial No.	Parts catalogue code
			(1)	(2)	(3)		
9	31218-ZE3-003	YOKE COMP. ....	1	-	-	-----	EDE2,EDE2/A,EDS,EDS1,EDS1/A,EDS2,EDS2/A,EDS3,EDS4,EDS5,EDS6 EDS6/A,EDT,EDT/A,ED7,ENT,ENT/A,ENT2,ES4,ES4/A,ETS,LHE,LHE/A,LKE LKE/A,LWD,LWD1,LWD1/A,LXE,LXE/A,LXE2,LXE2/A,LXE4,LXE4/A,LXE6,LXE8 LXE8/A,PXE8,PXE8/A,QAE,QAE2,QAE2/A,QAE6,QAE6/A,QAPE,QHE,QHE/A,QL2 QME0,QME0/A,QME8,QME8/A,QNE,QNE2,QNE2/A,QNE6,QNE9,QNE9/A,QNR2 QNR2/A,QNR6,QNR6/A,QN18,QPE2,QXE,QXE/A,QXEB,QXE2,QXE4,QXE4/A,QXE6 QXE6/A,QXE8,QXE8/A,SDE,SHE,SHEZ,SKE,SKE/A,SME0,SME0/A,SME2,STJ STJ/A,SXE,SXE/A,SXEB,SXEB/A,SXE2,SXE4,SXE4/A,SXE8,SXE8/A,VAAE VAH2,VEB6,VHE,VH22,VH22/A,VMQ,VMT,VMT/A,VNG2,VS5,VS6,VS7,VWA,VWA2 VWE,VWE2,VWE2/A,VWS2,VWS2/A,VXE,VXE/A,VXEB,VXEB/A,VXE2,VXE2/A VXE4,VXE6,VXE7,VXE7/A,VXE8,VXE8/A,VXU1,VXU1/A,ZK1,ZK1/A
10	31219-ZE2-003	SPRING, BRUSH RETURN .....	4	(1)	-	-----	EDE2,EDE2/A,EDS,EDS1,EDS1/A,EDS2,EDS2/A,EDS3,EDS4,EDS5,EDS6 EDS6/A,EDT,EDT/A,ED7,ENT,ENT/A,ENT2,ES4,ES4/A,ETS,LHE,LHE/A,LKE LKE/A,LWD,LWD1,LWD1/A,LXE,LXE/A,LXE2,LXE2/A,LXE4,LXE4/A,LXE6,LXE8 LXE8/A,PXE8,PXE8/A,QAE,QAE2,QAE2/A,QAE6,QAE6/A,QAPE,QHE,QHE/A,QL2 QME0,QME0/A,QME8,QME8/A,QNE,QNE2,QNE2/A,QNE6,QNE9,QNE9/A,QNR2 QNR2/A,QNR6,QNR6/A,QN18,QPE2,QXE,QXE/A,QXEB,QXE2,QXE4,QXE4/A,QXE6 QXE6/A,QXE8,QXE8/A,SDE,SHE,SHEZ,SKE,SKE/A,SME0,SME0/A,SME2,STJ STJ/A,SXE,SXE/A,SXEB,SXEB/A,SXE2,SXE4,SXE4/A,SXE8,SXE8/A,VAAE VAH2,VEB6,VHE,VH22,VH22/A,VMQ,VMT,VMT/A,VNG2,VS5,VS6,VS7,VWA,VWA2 VWE,VWE2,VWE2/A,VWS2,VWS2/A,VXE,VXE/A,VXEB,VXEB/A,VXE2,VXE2/A VXE4,VXE6,VXE7,VXE7/A,VXE8,VXE8/A,VXU1,VXU1/A,ZK1,ZK1/A
11	31222-ZE3-791	GEAR, REDUCTION .....	1	(4)	-	-----	EDE2,EDE2/A,EDS,EDS1,EDS1/A,EDS2,EDS2/A,EDS3,EDS4,EDS5,EDS6 EDS6/A,EDT,EDT/A,ED7,ENT,ENT/A,ENT2,ES4,ES4/A,ETS,LHE,LHE/A,LKE LKE/A,LWD,LWD1,LWD1/A,LXE,LXE/A,LXE2,LXE2/A,LXE4,LXE4/A,LXE6,LXE8 LXE8/A,PXE8,PXE8/A,QAE,QAE2,QAE2/A,QAE6,QAE6/A,QAPE,QHE,QHE/A,QL2 QME0,QME0/A,QME8,QME8/A,QNE,QNE2,QNE2/A,QNE6,QNE9,QNE9/A,QNR2 QNR2/A,QNR6,QNR6/A,QN18,QPE2,QXE,QXE/A,QXEB,QXE2,QXE4,QXE4/A,QXE6 QXE6/A,QXE8,QXE8/A,SDE,SHE,SHEZ,SKE,SKE/A,SME0,SME0/A,SME2,STJ STJ/A,SXE,SXE/A,SXEB,SXEB/A,SXE2,SXE4,SXE4/A,SXE8,SXE8/A,VAAE VAH2,VEB6,VHE,VH22,VH22/A,VMQ,VMT,VMT/A,VNG2,VS5,VS6,VS7,VWA,VWA2 VWE,VWE2,VWE2/A,VWS2,VWS2/A,VXE,VXE/A,VXEB,VXEB/A,VXE2,VXE2/A VXE4,VXE6,VXE7,VXE7/A,VXE8,VXE8/A,VXU1,VXU1/A,ZK1,ZK1/A
12	31231-ZE2-003	HOLDER, BRUSH .....	1	(1)	-	-----	EDE2,EDE2/A,EDS,EDS1,EDS1/A,EDS2,EDS2/A,EDS3,EDS4,EDS5,EDS6 EDS6/A,EDT,EDT/A,ED7,ENT,ENT/A,ENT2,ES4,ES4/A,ETS,LHE,LHE/A,LKE LKE/A,LWD,LWD1,LWD1/A,LXE,LXE/A,LXE2,LXE2/A,LXE4,LXE4/A,LXE6,LXE8 LXE8/A,PXE8,PXE8/A,QAE,QAE2,QAE2/A,QAE6,QAE6/A,QAPE,QHE,QHE/A,QL2 QME0,QME0/A,QME8,QME8/A,QNE,QNE2,QNE2/A,QNE6,QNE9,QNE9/A,QNR2 QNR2/A,QNR6,QNR6/A,QN18,QPE2,QXE,QXE/A,QXEB,QXE2,QXE4,QXE4/A,QXE6 QXE6/A,QXE8,QXE8/A,SDE,SHE,SHEZ,SKE,SKE/A,SME0,SME0/A,SME2,STJ STJ/A,SXE,SXE/A,SXEB,SXEB/A,SXE2,SXE4,SXE4/A,SXE8,SXE8/A,VAAE VAH2,VEB6,VHE,VH22,VH22/A,VMQ,VMT,VMT/A,VNG2,VS5,VS6,VS7,VWA,VWA2 VWE,VWE2,VWE2/A,VWS2,VWS2/A,VXE,VXE/A,VXEB,VXEB/A,VXE2,VXE2/A VXE4,VXE6,VXE7,VXE7/A,VXE8,VXE8/A,VXU1,VXU1/A,ZK1,ZK1/A
13	31232-ZB7-003	WIRE, WATER COVER .....	1	(1)	-	-----	EDS5



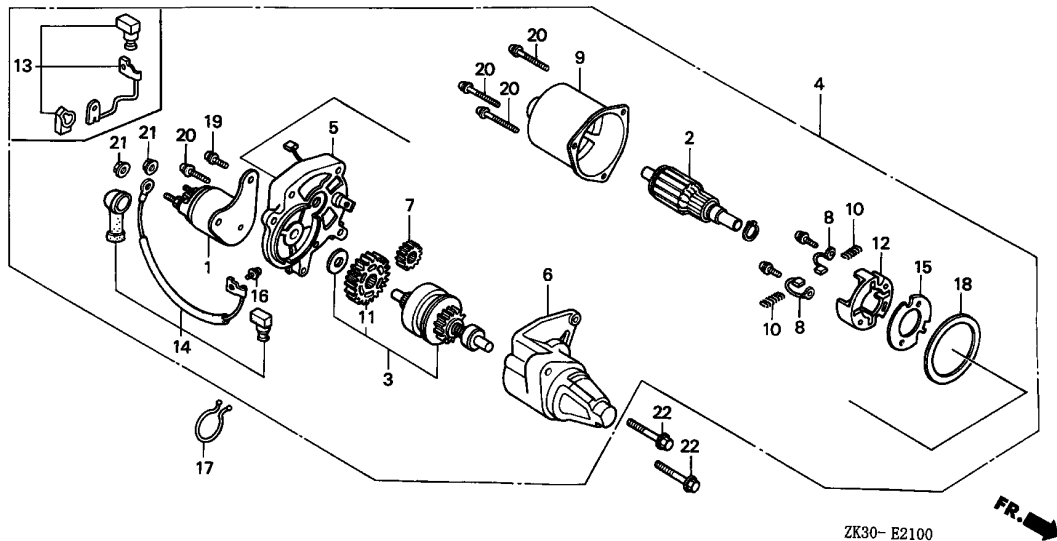

Ref. No.	Part No.	Description	Reqd. QTY			Serial No.	Parts catalogue code
			GX	(1)	(2)		
14	31232-ZE3-003	WIRE, WATER COVER .....	1	-	-	-	EDE2,EDE2/A,EDS,EDS1,EDS1/A,EDS2,EDS2/A,EDS3,EDS4,EDS6,EDS6/A,EDT,EDT/A,ED7,ENT,ENT/A,ENT2,ES4,ES4/A,ETS,LHE,LHE/A,LKE,LKE/A,LWD,LXE,LXE/A,LXE2,LXE2/A,LXE4,LXE4/A,LXE6,LXE8,LXE8/A,PXE8,PXE8/A,QAE,QAE2,QAE2/A,QAE6,QAE6/A,QAPE,QHE,QHE/A,QL2,QMEO,QMEO/A,QME8,QME8/A,QNE,QNE2,QNE2/A,QNE6,QNE9,QNE9/A,QNR2,QNR2/A,QNR6,QNR6/A,QN18,QPE2,QXE,QXE/A,QXEB,QXE2,QXE4,QXE4/A,QXE6,QXE6/A,QXE8,QXE8/A,SDE,SHE,SHEZ,SKE,SKE/A,SME0,SME0/A,SME2,STJ,STJ/A,SXE,SXE/A,SXEB,SXEB/A,SXE2,SXE4,SXE4/A,SXE8,SXE8/A,VAAE,VAH2,VEB6,VHE,VH22,VH22/A,VMQ,VMT,VMT/A,VNG2,VS5,VS6,VS7,VWA,VWA2,VWE,VWE2,VWE2/A,VWS2,VWS2/A,VXE,VXE/A,VXEB,VXEB/A,VXE2,VXE2/A,VXE4,VXE6,VXE7,VXE7/A,VXE8,VXE8/A,VXU1,VXU1/A,ZK1,ZK1/A
15	31233-ZE2-003	INSULATOR .....	1	(1)	-	-	EDE2,EDE2/A,EDS,EDS1,EDS1/A,EDS2,EDS2/A,EDS3,EDS4,EDS5,EDS6,EDS6/A,EDT,EDT/A,ED7,ENT,ENT/A,ENT2,ES4,ES4/A,ETS,LHE,LHE/A,LKE,LKE/A,LWD,LWD1,LWD1/A,LXE,LXE/A,LXE2,LXE2/A,LXE4,LXE4/A,LXE6,LXE8,LXE8/A,PXE8,PXE8/A,QAE,QAE2,QAE2/A,QAE6,QAE6/A,QAPE,QHE,QHE/A,QL2,QMEO,QMEO/A,QME8,QME8/A,QNE,QNE2,QNE2/A,QNE6,QNE9,QNE9/A,QNR2,QNR2/A,QNR6,QNR6/A,QN18,QPE2,QXE,QXE/A,QXEB,QXE2,QXE4,QXE4/A,QXE6,QXE6/A,QXE8,QXE8/A,SDE,SHE,SHEZ,SKE,SKE/A,SME0,SME0/A,SME2,STJ,STJ/A,SXE,SXE/A,SXEB,SXEB/A,SXE2,SXE4,SXE4/A,SXE8,SXE8/A,VAAE,VAH2,VEB6,VHE,VH22,VH22/A,VMQ,VMT,VMT/A,VNG2,VS5,VS6,VS7,VWA,VWA2,VWE,VWE2,VWE2/A,VWS2,VWS2/A,VXE,VXE/A,VXEB,VXEB/A,VXE2,VXE2/A,VXE4,VXE6,VXE7,VXE7/A,VXE8,VXE8/A,VXU1,VXU1/A,ZK1,ZK1/A

Ref. No.	Part No.	Description	Reqd. QTY			Serial No.	Parts catalogue code
			(1)	(2)	(3)		
16	90110-ZE2-003	SCREW-WASHER, 4X6 .....	1	-	-		EDE2,EDE2/A,EDS,EDS1,EDS1/A,EDS2,EDS2/A,EDS3,EDS4,EDS5,EDS6,EDS6/A,EDT,EDT/A,ED7,ENT,ENT/A,ENT2,ES4,ES4/A,ETS,LHE,LHE/A,LKE,LKE/A,LWD,LXE,LXE/A,LXE2,LXE2/A,LXE4,LXE4/A,LXE6,LXE8,LXE8/A,PXE8,PXE8/A,QAE,QAE2,QAE2/A,QAE6,QAE6/A,QAPE,QHE,QHE/A,QL2,QMEO,QMEO/A,QME8,QME8/A,QNE,QNE2,QNE2/A,QNE6,QNE9,QNE9/A,QNR2,QNR2/A,QNR6,QNR6/A,QN18,QPE2,QXE,QXE/A,QXEB,QXE2,QXE4,QXE4/A,QXE6,QXE6/A,QXE8,QXE8/A,SDE,SHE,SHEZ,SKE,SKE/A,SME0,SME0/A,SME2,STJ,STJ/A,SXESXE/A,SXEB,SXEB/A,SXE2,SXE4,SXE4/A,SXE8,SXE8/A,VAAE,VAH2,VEB6,VH22,VH22/A,VMQ,VMT,VMT/A,VNG2,VS5,VS6,VS7,VWA,VWA2,VWE,VWE2,VWE2/A,VWS2,VWS2/A,VXE,VXE/A,VXEB,VXEB/A,VXE2,VXE2/A,VXE4,VXE6,VXE7,VXE7/A,VXE8,VXE8/A,VXU1,VXU1/A,ZK1,ZK1/A
17	90630-751-000	CLIP, PURSE LOCK .....	1	(1)	-		EDS,EDS3,EDS5,LXE4,LXE4/A,PXE8,PXE8/A,QMEO,QMEO/A,QME8,QME8/A,QXE4,QXE4/A,SDE,SKE,SKE/A,SME0,SME0/A,SXE4,SXE4/A,VXE4
18	91601-ZE2-003	PACKING .....	1	-	-	3400701	EDS1,EDS2,EDS6,EDT,ENT EDE2,EDE2/A,EDS,EDS1,EDS1/A,EDS2,EDS2/A,EDS3,EDS4,EDS5,EDS6,EDS6/A,EDT,EDT/A,ED7,ENT,ENT/A,ENT2,ES4,ES4/A,ETS,LHE,LHE/A,LKE,LKE/A,LWD,LWD1,LWD1/A,LXE,LXE/A,LXE2,LXE2/A,LXE4,LXE4/A,LXE6,LXE8,LXE8/A,PXE8,PXE8/A,QAE,QAE2,QAE2/A,QAE6,QAE6/A,QAPE,QHE,QHE/A,QL2,QMEO,QMEO/A,QME8,QME8/A,QNE,QNE2,QNE2/A,QNE6,QNE9,QNE9/A,QNR2,QNR2/A,QNR6,QNR6/A,QN18,QPE2,QXE,QXE/A,QXEB,QXE2,QXE4,QXE4/A,QXE6,QXE6/A,QXE8,QXE8/A,SDE,SHE,SHEZ,SKE,SKE/A,SME0,SME0/A,SME2,STJ,STJ/A,SXE,SXE/A,SXEB,SXEB/A,SXE2,SXE4,SXE4/A,SXE8,SXE8/A,VAAE,VAH2,VEB6,VH22,VH22/A,VMQ,VMT,VMT/A,VNG2,VS5,VS6,VS7,VWA,VWA2,VWE,VWE2,VWE2/A,VWS2,VWS2/A,VXE,VXE/A,VXEB,VXEB/A,VXE2,VXE2/A,VXE4,VXE6,VXE7,VXE7/A,VXE8,VXE8/A,VXU1,VXU1/A,ZK1,ZK1/A
19	93892-05014-18	SCREW-WASHER, 5X14 .....	2	(1)	(2)	2630806	EDE2,EDS,EDS1,EDS3,EDS5,ED7,ES4,ETS,LHE,LKE,LXE,LXE2,LXE4,LXE6,L1P1,QAE,QAE2,QAE6,QAPE,QHE,QMEO,QNE,QNE2,QNE6,QNE9,QNR2,QNR6,QN18,QPE2,QXE,QXEB,QXE2,QXE4,QXE6,Q1,SDE,SHE,SHEZ,SME0,SME2,STJ,SXESXEB,SXE2,SXE4,S1,VAAE,VAH2,VEB6,VHE,VH22,VNG2,VWA,VWA2,VWE2,VWS2,VXE,VXEB,VXE2,VXE4,VXE6,VXU1,V1,ZK1
	90007-ZE2-003	BOLT-WASHER, 5X14 .....	2	(2)	-		EDE2/A,EDS1/A,EDS2,EDS2/A,EDS4,EDS6,EDS6/A,EDT,EDT/A,ENT,ENT/A,ENT2,ES4/A,LHE/A,LKE/A,LWD,LXE/A,LXE2/A,LXE4/A,LXE8,LXE8/A,L1/A,PXE8,PXE8/A,P1/A,QAE2/A,QAE6/A,QHE/A,QL2,QMEO/A,QME8,QME8/A,QNE2/A,QNE9/A,QNR2/A,QNR6/A,QXE/A,QXE4/A,QXE6/A,QXE8,QXE8/A,Q1/A,SKE,SKE/A,SME0/A,STJ/A,SXE/A,SXEB/A,SXE4/A,SXE8,SXE8/A,S1/A,VH22/A,VMQ,VMT,VMT/A,VS5,VS6,VS7,VWE,VWE2/A,VWS2/A,VXE/A,VXEB/A,VXE2/A,VXE7,VXE7/A,VXE8,VXE8/A,VXU1/A,ZK1/A
			2	(2)	-	2630807	EDE2,EDS,EDS1,EDS3,EDS5,ED7,ES4,ETS,LHE,LKE,LXE,LXE2,LXE4,LXE6,L1P1,QAE,QAE2,QAE6,QAPE,QHE,QMEO,QNE,QNE2,QNE6,QNE9,QNR2,QNR6,QN18,QPE2,QXE,QXEB,QXE2,QXE4,QXE6,Q1,SDE,SHE,SHEZ,SME0,SME2,STJ,SXESXEB,SXE2,SXE4,S1,VAAE,VAH2,VEB6,VHE,VH22,VNG2,VWA,VWA2,VWE2,VWS2,VXE,VXEB,VXE2,VXE4,VXE6,VXU1,V1,ZK1
20	93892-05032-18	SCREW-WASHER, 5X32 .....	4	-	-		EDE2,EDE2/A,EDS,EDS1,EDS1/A,EDS2,EDS2/A,EDS3,EDS4,EDS5,EDS6,EDS6/A,EDT,EDT/A,ED7,ENT,ENT/A,ENT2,ES4,ES4/A,ETS,LHE,LHE/A,LKE,LKE/A,LWD,LWD1,LWD1/A,LXE,LXE/A,LXE2,LXE2/A,LXE4,LXE4/A,LXE6,LXE8,LXE8/A,PXE8,PXE8/A,QAE,QAE2,QAE2/A,QAE6,QAE6/A,QAPE,QHE,QHE/A,QL2,QMEO,QMEO/A,QME8,QME8/A,QNE,QNE2,QNE2/A,QNE6,QNE9,QNE9/A,QNR2,QNR2/A,QNR6,QNR6/A,QN18,QPE2,QXE,QXE/A,QXEB,QXE2,QXE4,QXE4/A,QXE6,QXE6/A,QXE8,QXE8/A,SDE,SHE,SHEZ,SKE,SKE/A,SME0,SME0/A,SME2,STJ,STJ/A,SXE,SXE/A,SXEB,SXEB/A,SXE2,SXE4,SXE4/A,SXE8,SXE8/A,VAAE,VAH2,VEB6,VH22,VH22/A,VMQ,VMT,VMT/A,VNG2,VS5,VS6,VS7,VWA,VWA2,VWE,VWE2,VWE2/A,VWS2,VWS2/A,VXE,VXE/A,VXEB,VXEB/A,VXE2,VXE2/A,VXE4,VXE6,VXE7,VXE7/A,VXE8,VXE8/A,VXU1,VXU1/A,ZK1,ZK1/A
			-	(4)	-		



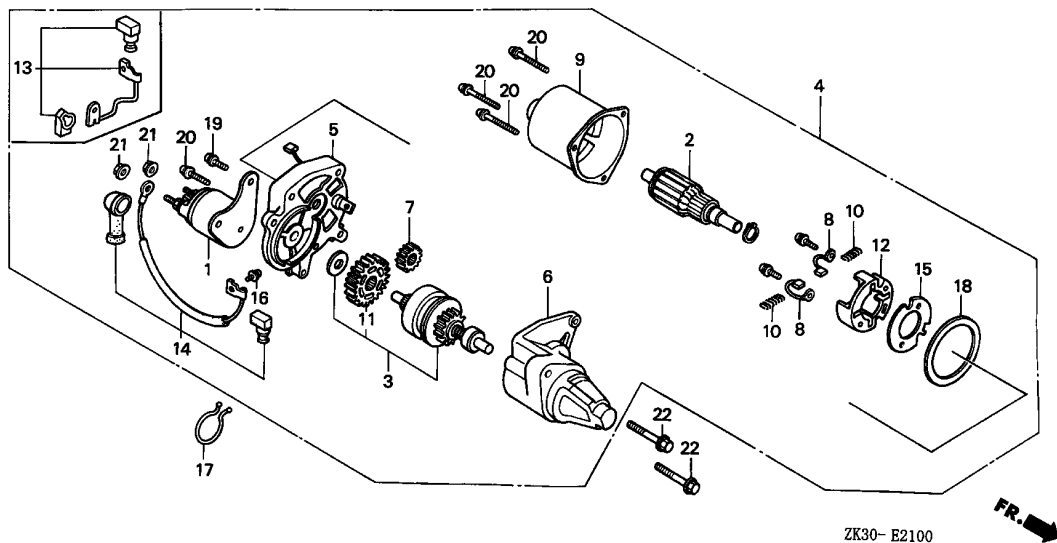

Ref. No.	Part No.	Description	Reqd. QTY			Serial No.	Parts catalogue code
			GX	(1)	(2)		
21	94070-06080	NUT-WASHER, 6MM .....	2	-	-	-----	EDE2,EDE2/A,EDS,EDS1,EDS1/A,EDS2,EDS2/A,EDS3,EDS4,EDS5,EDS6 EDS6/A,EDT,EDT/A,ED7,ENT,ENT/A,ENT2,ES4,ES4/A,ETS,LHE,LHE/A,LKE LKE/A,LWD,LXE,LXE/A,LXE2,LXE2/A,LXE4,LXE4/A,LXE6,LXE8,LXE8/A,PXE8 PXE8/A,QAE,QAE2,QAE2/A,QAE6,QAE6/A,QAPE,QHE,QHE/A,QL2,QMEO,QMEO/A QME8,QME8/A,QNE,QNE2,QNE2/A,QNE6,QNE9,QNE9/A,QNR2,QNR2/A,QNR6 QNR6/A,QN18,QPE2,QXE,QXE/A,QXEB,QXE2,QXE4,QXE4/A,QXE6,QXE6/A,QXE8 QXE8/A,SDE,SHE,SHEZ,SKE,SKE/A,SME0,SME0/A,SME2,STJ,STJ/A,SXE SXE/A,SXEB,SXEB/A,SXE2,SXE4,SXE4/A,SXE8,SXE8/A,VAAE,VAH2,VEB6,VHE VH22,VH22/A,VMQ,VMT,VMT/A,VNG2,VS5,VS6,VS7,VWA,VWA2,VWE,VWE2 VWE2/A,VWS2,VWS2/A,VXE,VXE/A,VXEB,VXEB/A,VXE2,VXE2/A,VXE4,VXE6 VXE7,VXE7/A,VXE8,VXE8/A,VXU1,VXU1/A,ZK1,ZK1/A
22	95701-08035-08	BOLT, FLANGE, 8X35 .....	2	(2)	-	-----	EDE2,EDE2/A,EDS,EDS1,EDS1/A,EDS2,EDS2/A,EDS3,EDS4,EDS5,EDS6 EDS6/A,EDT,EDT/A,ED7,ENT,ENT/A,ENT2,ES4,ES4/A,ETS,LHE,LHE/A,LKE LKE/A,LWD,LWD1,LWD1/A,LXE,LXE/A,LXE2,LXE2/A,LXE4,LXE4/A,LXE6,LXE8 LXE8/A,PXE8,PXE8/A,QAE,QAE2,QAE2/A,QAE6,QAE6/A,QAPE,QHE,QHE/A,QL2 QMEO,QMEO/A,QME8,QME8/A,QNE,QNE2,QNE2/A,QNE6,QNE9,QNE9/A,QNR2 QNR2/A,QNR6,QNR6/A,QN18,QPE2,QXE,QXE/A,QXEB,QXE2,QXE4,QXE4/A,QXE6 QXE6/A,QXE8,QXE8/A,SDE,SHE,SHEZ,SKE,SKE/A,SME0,SME0/A,SME2,STJ STJ/A,SXE,SXE/A,SXEB,SXEB/A,SXE2,SXE4,SXE4/A,SXE8,SXE8/A,VAAE VAH2,VEB6,VHE,VH22,VH22/A,VMQ,VMT,VMT/A,VNG2,VS5,VS6,VS7,VWA,VWA2 VWE,VWE2,VWE2/A,VWS2,VWS2/A,VXE,VXE/A,VXEB,VXEB/A,VXE2,VXE2/A VXE4,VXE6,VXE7,VXE7/A,VXE8,VXE8/A,VXU1,VXU1/A,ZK1,ZK1/A

2

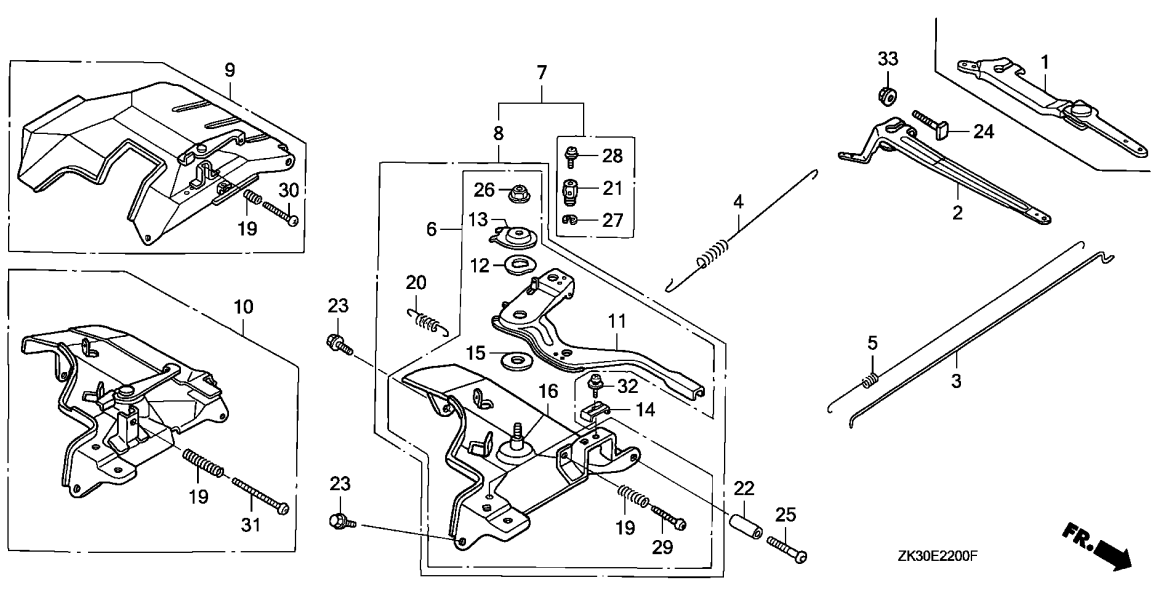

Ref. No.	L.O.N.	(Relative ref. Number) Description	F.R.T.
2		(1)	
2	1161A0	ARM, GOVERNOR .....	0.2
3	1161B1	ROD, GOVERNOR .....	0.3
4	1161C5	SPRING, GOVERNOR .....	0.2
5	1161C2	SPRING, THROTTLE RETURN .....	0.3
7		(9,10)	
	1161A5	CONTROL, THROTTLE/GOVERNOR ...	0.2
11	1161A8	LEVER, CONTROL .....	0.3
16	1161A2	BASE, CONTROL .....	0.3
20	1161B7	SPRING, CABLE RETURN .....	0.1

Ref. No.	Part No.	Description	Reqd. QTY			Serial No.	Parts catalogue code
			GX	(1)	(2)		
1	16550-ZE3-700	ARM COMP., GOVERNOR .....	1	-	-	-----	EDE2,EDE2/A,EDN,EDN2,EDN2/A,EDS,EDS3,EDS4,EDS5,EDS6,EDS6/A,EDT3,EDT6,EDT6/A,ED6/A,EMT,EMT/A,ENT2,EN6,EN6/A,VAH1,VAH2,VC2,VC2/A,VH12,VH12/A,VH22,VH22/A,VMQ,VMT,VMT/A,VWA,VWA2,VWC,VVE
2	16551-ZE3-000	ARM, GOVERNOR .....	1	-	-	2374606	ED6
			1	-	-	-----	EDK,EDN5,EDN5/A,ED7,ED8,ED8/A,ED9,ED9/A,EN,ES,ES1,ES1/A,ES2,ES3,ES3/A,ES4,ES4/A,ET,ETS,ETX,HA,HAQ,HA2,HA2/A,HH,HX,HX2,HX26,HX26/A,LH,LH/A,LHB1,LHB3,LHB3/A,LHB5,LHC,LHE,LHE/A,LHQ4,LHQ4/A,LHW,LJS,LJS/A,LJS1,LKE,LKE/A,LT,LT/A,LWD,LX,LX/A,LXE,LXE/A,LXE2,LXE2/A,LXE4,LXE4/A,LXE6,LXE8,LXE8/A,LXQ4,LXQ4/A,LXU,LXU/A,LX2,LX2/A,LX26,LX26/A,PKT2,PKT2/A,PKT4,PKT4/A,PKX2,PKX4,PKX4/A,PX,PX/A,PXA2,PXE8,PXE8/A,QA,QAE,QAE2,QAE2/A,QAE6,QAE6/A,QAP,QAPE,QAP2,QAP2/A,QAQ,QA2,QA2/A,QA26,QA26/A,QDW9,QDW9/A,QE,QE/A,QH,QH/A,QHB3,QHB3/A,QHB5,QHC,QHE,QHE/A,QHP1,QHP1/A,QHQ4,QHQ4/A,QH2,QKA4,QKA4/A,QMEO,QMEO/A,QME8,QME8/A,QMH,QMH/A,QMT2,QMT2/A,QNE,QNE2,QNE2/A,QNE6,QNE9,QNE9/A,QNR2,QNR2/A,QNR6,QNR6/A,QN18,QP,QP/A,QPE2,QT,QT/A,QTC2,QTC2/A,QX,QX/A,QXB,QXB/A,QXB7,QXB7/A,QXC,QXC/A,QXC4,QXC4/A,QXC6,QXC6/A,QXC9,QXC9/A,QXE,QXE/A,QXEB,QXE2,QXE4,QXE4/A,QXE6,QXE6/A,QXE8,QXE8/A,QXQ4,QXQ4/A,QXU,QXU/A,QX2,SE,SE/A,SH,SH/A,SHB1,SHB3,SHB3/A,SHE,SHEZ,SHQ4,SHQ4/A,SHT,SME0,SME0/A,SME2,SMX2,SMX2/A,SWX,SWX/A,SX,SX/A,SXB,SXB/A,SXB7,SXB7/A,SXE,SXE/A,SXEB,SXEB/A,SXE2,SXE4,SXE4/A,SXE8,SXE8/A,SXP,SXQ4,SXQ4/A,SXU,SXU/A,VA,VA,VAA,VAE,VAD2,VAD2/A,VAW1,VA2,VA2/A,VDE,VDE2,VDE2/A,VD16,VE,VEB6,VH,VHE,VMX,VNG,VNG1,VNG2,VSH7,VS2,VS3,VS4,VS5,VS6,VS7,VTE2,VWC2,VWC2/A,VWE2,VWE2/A,VWS2,VWS2/A,VW12,VW12/A,VX,VX/A,VXA,VXB,VXB/A,VXB2,VXB7,VXB7/A,VXE,VXE/A,VXEB,VXEB/A,VXE2,VXE2/A,VXE4,VXE6,VXE7,VXE7/A,VXE8,VXE8/A,VXG,VXK,VXQ4,VXQ4/A,VXU,VXU/A,VXU1,VXU1/A,VX16,VX16/A,VX8,VX8/A
			1	-	-	2374605	ED6
			-	1	1		



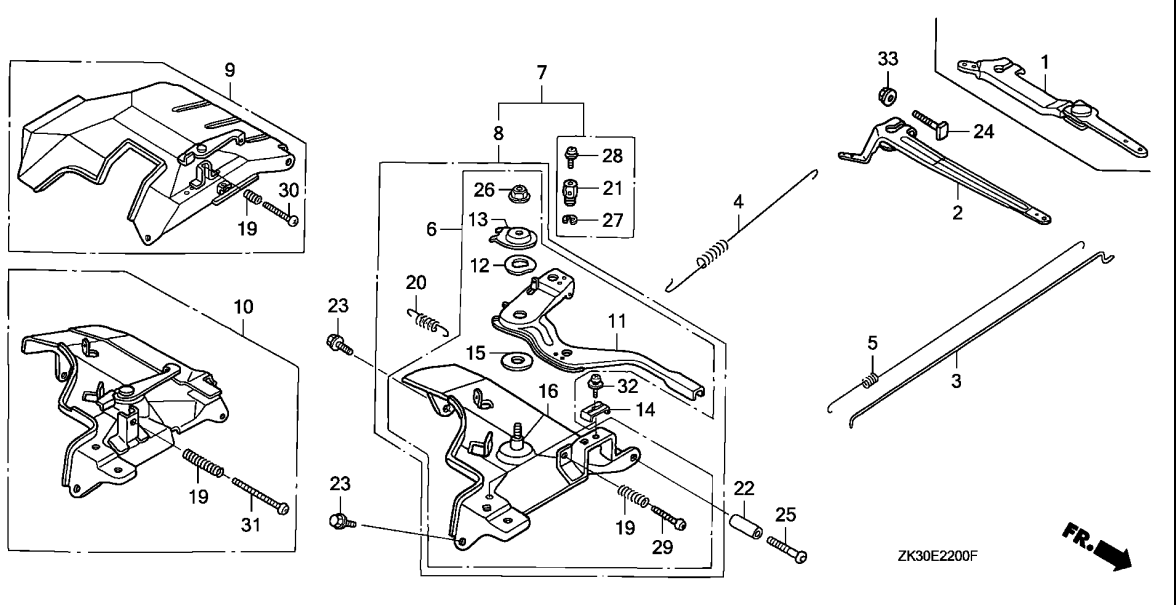

Ref. No.	Part No.	Description	Reqd. QTY			Serial No.	Parts catalogue code					
			GX	340K1								
3	16555-ZE3-000	ROD, GOVERNOR .....	(1)	(2)	(3)	2117541	EN,ES,ES1,ES3,ET,ETS,ETX,HA,HH,HX,LHC,LX,LXZ,L1,P1,QA,QAE,QAP QAPE,QHC,QNE,QP,QT,QXC,QXEB,Q1,SHE,SHEZ,SWX,SXP,S1,VA,VAA,VAE,VE VH,VHE,VNG,VNG1,VNG2,VX,VXA,VXB,VXE,VXEB,V1 EDE2,EDE2/A,EDK,EDN,EDN2,EDN2/A,EDN5,EDN5/A,EDS,EDS3,EDS4,EDS5 EDS6,EDS6/A,EDT3,EDT6,EDT6/A,ED6,ED6/A,ED8/A,ED9/A,EMT,EMT/A,ENT2 EN6,EN6/A,ES2,ES4,ES4/A,HA2,HA2/A,HX2,HX26,HX26/A,LH/A,LHB3/A LHB5,LHE/A,LHQ4/A,LJS,LJS/A,LJS1,LKE/A,LWD,LXE/A,LXE2,LXE2/A LXE4/A,LXE6,LXE8/A,LXQ4/A,LXU/A,LX2,LX2/A,LX26,LX26/A,PKT2/A PKT4,PKT4/A,PKX2,PKX4/A,PX/A,QAE2,QAE2/A,QAE6,QAE6/A,QAP2,QAP2/A QA2,QA2/A,QA26,QA26/A,QDW9,QDW9/A,QE/A,QH/A,QHB3/A,QHB5,QHE/A QHP1/A,QHQ4/A,QH2,QMEO/A,QMH/A,QMT2,QMT2/A,QNE2,QNE2/A,QNE6 QNE9/A,QNR2,QNR2/A,QNR6,QNR6/A,QPE2,QTC2,QTC2/A,QX/A,QXB/A,QXB7 QXB7/A,QXC6,QXC6/A,QXC9,QXC9/A,QXE/A,QXE2,QXE4/A,QXE6,QXE6/A QXE8/A,QXQ4/A,QXU/A,QX2,SE/A,SH/A,SHB3/A,SHQ4/A,SME0/A,SME2,SMX2 SMX2/A,SX/A,SXB/A,SXB7,SXB7/A,SXE/A,SXEB/A,SXE2,SXE4/A,SXE8/A SXQ4/A,SXU/A,VAD2,VAD2/A,VA2,VA2/A,VC2,VC2/A,VDE2,VDE2/A,VH12 VH12/A,VH22,VH22/A,VMQ,VMT,VMT/A,VMX,VSH7,VS2,VS3,VS4,VS5,VS6,VS7 VTE2,VWA2,VWC,VWC2,VWC2/A,VWE,VWE2,VWE2/A,VWS2,VWS2/A,VW12,VW12/A VXB2,VXB7,VXB7/A,VXE2,VXE2/A,VXE6,VXE7,VXE7/A,VXE8,VXE8/A,VXK VXQ4/A,VXU/A,VXU1/A,VX16/A,VX8,VX8/A	1	1	-	2240293	HAQ,QAQ,QNE9
			1	-	-	2589544	ED7,ED8,ED9,VD16,VEB6,VXE4,VXG,VXQ4,VXU,VXU1,VX16					
			1	-	-	3032024	LH,LHB3,LHE,LHQ4,LKE,LXE,LXE4,LXE8,LXQ4,LXU,PX,QE,QH,QHB3,QHE QHP1,QHQ4,QMEO,QMH,QN18,QX,QXB,QXE,QXE4,QXE8,QXQ4,QXU,SE,SH,SHB1 SHB3,SHQ4,SME0,SX,SXB,SXE,SXEB,SXE4,SXE8,SXQ4,SXU					
			1	-	-	3129574	PKX4					

2

Ref. No.	Part No.	Description	Reqd. QTY			Serial No.	Parts catalogue code	
			(1)	(2)	(3)			
(3)	16555-ZE3-W00	ROD, GOVERNOR (STD.) .....	1	1	-	-----	ES1/A,ES3/A,LHB1,LHW,LT,LT/A,LX/A,L1/A,PXA2,PXE8,PXE8/A,P1/A,QKA4	
			1	1	-	2117542	-----	QKA4/A,QME8,QME8/A,QP/A,QT/A,QXC/A,QXC4,QXC4/A,Q1/A,SHT,SWX/A
			1	-	-	2240292	-----	S1/A,VAH1,VAH2,VAW1,VDE,VVA,VX/A,VXB/A,VXB2,VXE/A,VXEB/A
			1	-	-	2589543	-----	EN,ES,ES1,ES3,ET,ETS,ETX,HA,HH,HX,LHC,LX,LXZ,L1,P1,QA,QAE,QAP
			1	-	-	3032023	-----	QAPE,QHC,QNE,QP,QT,QXC,QXEB,Q1,SHE,SHEZ,SWX,SXP,S1,VA,VAA,VAAE,VE
			1	-	-	3129573	-----	VH,VHE,VNG,VNG1,VNG2,VX,VXA,VXB,VXE,VXEB,V1
4	16561-ZE3-000	SPRING, GOVERNOR .....	1	-	-	-----	HAQ,QAQ,QNE9	
			1	-	-	-----	ED7,ED8,ED9,VD16,VEB6,VXE4,VXG,VXQ4,VXU,VXU1,VX16	
			1	-	-	-----	LH,LHB3,LHE,LHQ4,LKE,LXE,LXE4,LXE8,LXQ4,LXU,PX,QE,QH,QHB3,QHE	
			1	-	-	-----	QHP1,QHQ4,QMEO,QMH,QN18,QX,QXB,QXE,QXE4,QXE8,QXQ4,QXU,SE,SH,SHB1	
			1	-	-	-----	SHB3,SHQ4,SME0,SX,SXB,SXE,SXEB,SXE4,SXE8,SXQ4,SXU	
			1	-	-	-----	PKX4	
16561-ZE3-710	.....	.....	1	-	-	-----	EDE2,EDE2/A,EDN,EDN2,EDN2/A,EDS,EDS3,EDS4,EDS5,EDS6,EDS6/A,EDT3	
			1	1	1	-----	EDT6,EDT6/A,ED6,ED6/A,EMT,EMT/A,ENT2,EN6,EN6/A,ES3,ES3/A,ES4	
			1	-	-	-----	ES4/A,HA,HAQ,HA2,HA2/A,HH,HX,HX2,HX26,HX26/A,LH,LH/A,LHB1,LHB3	
			1	-	-	-----	LHB3/A,LHB5,LHC,LHE,LHE/A,LHQ4,LHQ4/A,LHW,LJS,LJS/A,LJS1,LKE	
			1	-	-	-----	LKE/A,LT,LT/A,LWD,LX,LX/A,LXE,LXE/A,LXE2,LXE2/A,LXE4,LXE4/A,LXE6	
			1	-	-	-----	LXE8,LXE8/A,LXQ4,LXQ4/A,LXU,LXU/A,LXZ,LX2,LX2/A,LX26,LX26/A,PKT2	



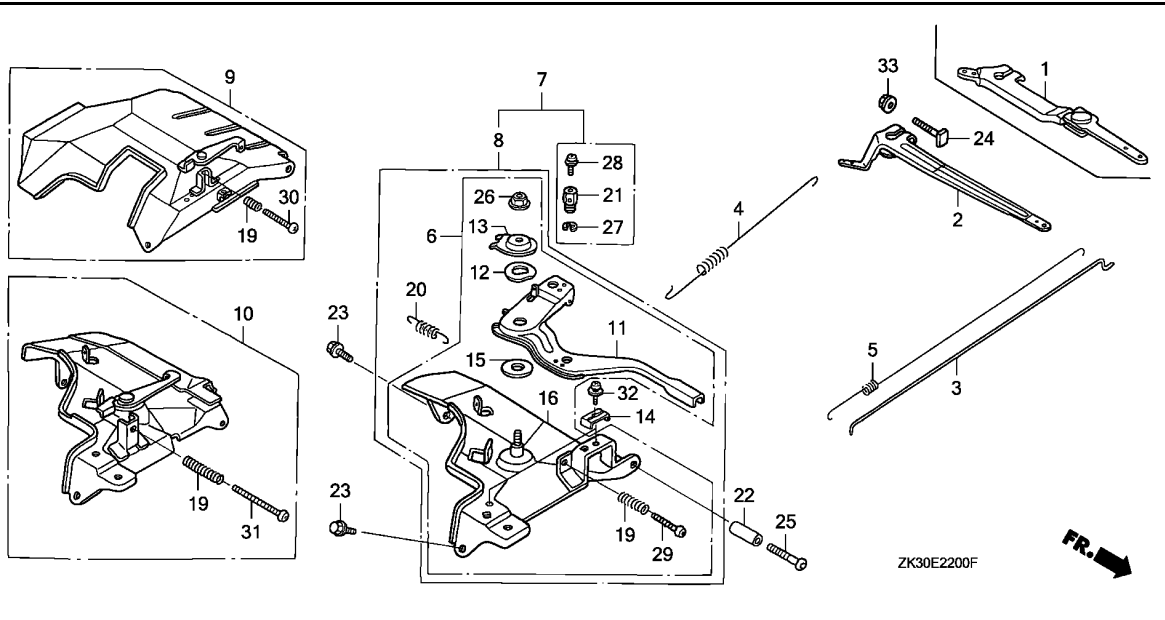

Ref. No.	Part No.	Description	Reqd. QTY			Serial No.	Parts catalogue code						
			GX	340K1									
			(1)	(2)	(3)								
5	16562-ZE3-000	SPRING, THROTTLE RETURN .....	1	-	-	-----	EDK,EDN5,EDN5/A,ED7,ED8,ED8/A,ED9,ED9/A,EN,ES,ES1,ES1/A,ES2,ES3,ES3/A,ES4,ES4/A,ET,ETS,ETX,HA,HAQ,HA2,HA2/A,HH,HX,HX2,HX26,HX26/A,LH,LH/A,LHB1,LHB3,LHB3/A,LHB5,LHC,LHE,LHE/A,LHQ4,LHQ4/A,LHW,LJS,LJS/A,LJS1,LKE,LKE/A,LT,LT/A,LWD,LX,LX/A,LXE,LXE/A,LXE2,LXE2/A,LXE4,LXE4/A,LXE6,LXE8,LXE8/A,LXQ4,LXQ4/A,LXU,LXU/A,LX2,LX2/LX26,LX26/A,PKT2,PKT2/A,PKT4,PKT4/A,PKX2,PKX4,PKX4/A,PX,PX/A,PKA2,PXE8,PXE8/A,QA,QAE,QAE2,QAE2/A,QAE6,QAE6/A,QAP,QAPE,QAP2,QAP2/A,QAQ,QA2,QA2/A,QA26,QA26/A,QDW9,QDW9/A,QE,QE/A,QH,QH/A,QHB3,QHB3/A,QHB5,QHC,QHE,QHE/A,QHP1,QHP1/A,QHQ4,QHQ4/A,QH2,QKA4,QKA4/A,QMEO,QMEO/A,QME8,QME8/A,QMH,QMH/A,QMT2,QMT2/A,QNE,QNE2,QNE2/A,QNE6,QNE9,QNE9/A,QNR2,QNR2/A,QNR6,QNR6/A,QN18,QP,QP/A,QPE2,QT,QT/A,QTC2,QTC2/A,QX,QX/A,QXB,QXB/A,QXB7,QXB7/A,QXC,QXC/A,QXC4,QXC4/A,QXC6,QXC6/A,QXC9,QXC9/A,QXE,QXE/A,QXEB,QXE2,QXE4,QXE4/A,QXE6,QXE6/A,QXE8,QXE8/A,QXQ4,QXQ4/A,QXU,QXU/A,QX2,SE,SE/A,SH,SH/A,SHB1,SHB3,SHB3/A,SHE,SHEZ,SHQ4,SHQ4/A,SHT,SME0,SME0/A,SME2,SMX2,SMX2/A,SWX,SWX/A,SX,SX/A,SXB,SXB/A,SXB7,SXB7/A,SXE,SXE/A,SXEB,SXEB/A,SXE2,SXE4,SXE4/A,SXE8,SXE8/A,SXP,SXQ4,SXQ4/A,VA,VAE,VAE,VAE2,VAE2/A,VAW1,VA2,VA2/A,VDE,VDE2,VDE2/A,VD16,VE,VEB6,VH,VHE,VMX,VNG,VNG1,VNG2,VSH7,VS2,VS3,VS4,VS5,VS6,VS7,VTE2,VWC2,VWC2/A,VWE2,VWE2/A,VWS2,VWS2/A,VW12,VW12/A,VX,VX/A,VXA,VXB,VXB/A,VXB2,VXB7,VXB7/A,VXE,VXE/A,VXEB,VXEB/A,VXE2,VXE2/A,VXE4,VXE6,VXE7,VXE7/A,VXE8,VXE8/A,VXG,VXK,VXQ4,VXQ4/A,VXU,VXU/A,VXU1,VXU1/A,VX16,VX16/A,VX8,VX8/A	1	-	-	-----	2374605	ED6
	16562-ZE3-700	.....	1	-	-	-----	EDE2,EDE2/A,EDN,EDN2,EDN2/A,EDS,EDS3,EDS4,EDS5,EDS6,EDS6/A,EDT3,EDT6,EDT6/A,ED6/A,EMT,EMT/A,ENT2,EN6,EN6/A,VAH1,VAH2,VC2,VC2/A,VH12,VH12/A,VH22,VH22/A,VMQ,VMT,VMT/A,VWA,VWA2,VWC,VWE	1	-	-	-----	2374606	ED6





Ref. No.	Part No.	Description	Reqd. QTY			Serial No.	Parts catalogue code
			(1)	(2)	(3)		
6	16570-ZE3-W00	CONTROL ASSY. (STD.)	1	-	-	PKT2,PKT2/A,PKT4,PKT4/A,PKX2,PKX4,PKX4/A,PXA2,VAA,VAE,VDE,VDE2,VDE2/A,VD16,VE,VEB6,VH,VHE,VMX,VX,VX/A,VXA,VXB,VXB/A,VXB2,VXE,VXE/A,VXEB,VXEB/A,VXE2,VXE2/A,VXE4,VXE6,VXQ4,VXQ4/A,VX16,VX16/A	
			1	-	-	2540276 VAH2,VH22	
	16570-ZE3-W30	CONTROL ASSY. (REMOTE)	-	(1)	1		
			1	-	-	VAD2,VAD2/A,VNG,VNG1,VNG2	
	16570-ZK3-870	CONTROL ASSY.	1	-	-	VXB7,VXB7/A,VXE7,VXE7/A	
7	16570-ZE3-W10	CONTROL ASSY. (REMOTE)	1	-	-	LHW,LT,LT/A,LWD,QAP,QAP2,QAP2/A,QDW9,QDW9/A,QKA4,QKA4/A,QPE2,QTC2,QTC2/A,SME2,SMX2,SMX2/A,SXP	
			1	-	-	2084185 QAPE	
	16570-ZE3-W40	CONTROL ASSY. (REMOTE) (W/PLUG)	1	-	-	LJS,LJS/A,LJS1,LKE,LKE/A	
			1	-	-	2084184 QAPE	
8	16570-ZE3-W20	CONTROL ASSY. (REMOTE)	1	-	-	HA,HAQ,HA2,HA2/A,HH,HX,HX2,HX26,HX26/A,LH,LH/A,LHB1,LHB3,LHB3/A,LHB5,LHC,LHE,LHE/A,LHQ4,LHQ4/A,LX,LX/A,LXE,LXE/A,LXE2,LXE2/A,LXE4,LXE4/A,LXE6,LXE8,LXE8/A,LXQ4,LXQ4/A,LXU,LXU/A,LXZ,LXZ/A,LX26,LX26/A,PX,PX/A,PXE8,PXE8/A,QA,QAE,QAE2,QAE2/A,QAE6,QAE6/A,QAQ,QA2,QA2/A,QA26,QA26/A,QE,QE/A,QH,QH/A,QHB3,QHB3/A,QHB5,QHC,QHE,QHE/A,QHP1,QHP1/A,QHQ4,QHQ4/A,QH2,QMEO,QMEO/A,QME8,QME8/A,QMH,QMH/A,QMT2,QMT2/A,QNE,QNE2,QNE2/A,QNE6,QNE9,QNE9/A,QNR2,QNR2/A,QNR6,QNR6/A,QN18,QP,QP/A,QT,QT/A,QX,QX/A,QXB,QXB/A,QXB7,QXB7/A,QXC,QXC/A,QXC4,QXC4/A,QXC6,QXC6/A,QXC9,QXC9/A,QXE,QXE/A,QXE6,QXE6/A,QXE8,QXE8/A,QXQ4,QXQ4/A,QXU,QXU/A,QX2,SE,SE/A,SH,SH/A,SHB1,SHB3,SHB3/A,SHE,SHE2,SHQ4,SHQ4/A,SHT,SMEO,SMEO/A,SWX,SWX/A,SX,SX/A,SXB,SXB/A,SXB7,SXB7/A,SXE,SXE/A,SXEB,SXEB/A,SXE2,SXE4,SXE4/A,SXE8,SXE8/A,SXQ4,SXQ4/A,SXU,SXU/A,VA,VA2,VA2/A	
			1	-	-	2540276 VAH1,VH12	
9	16570-ZE3-700	CONTROL ASSY.	1	-	-	EDE2,EDE2/A,EDN,EDN2,EDN2/A,EDS,EDS3,EDS4,EDS6,EDS6/A,EDT3,EDT6,EDT6/A,ED6,ED6/A,ENT2,EN6,EN6/A,ES3,ES3/A,ES4,ES4/A,VS2,VS3,VS4,VS5,VS6,VS7,VTE2,VWC,VWE	
	16570-ZE3-710	.....	1	-	-	EMT,EMT/A,VMQ,VMT,VMT/A	
10	16570-ZE3-721	CONTROL ASSY.	1	-	-	EDK,EDN5,EDN5/A,ED7,ED8,ED8/A,ED9,ED9/A,EN,ES,ES1,ES1/A,ES2,ET,ETS,ETX,VAW1,VH12/A,VH22/A,VWA,VWA2,VWC2,VWC2/A,VWE2,VWE2/A,VWS2,VWS2/A,VW12,VW12/A,VXE8,VXE8/A,VXG,VXK,VXU,VXU/A,VXU1,VXU1/A,VX8/A	
			1	-	-	2540277 VAH1,VAH2,VH12,VH22	
			1	-	-	3400223 VC2	
	16570-ZK3-S60	.....	1	-	-	VC2/A	
			1	-	-	3400224 VC2	
	16570-ZK3-D20	.....	1	-	-	VSH7	



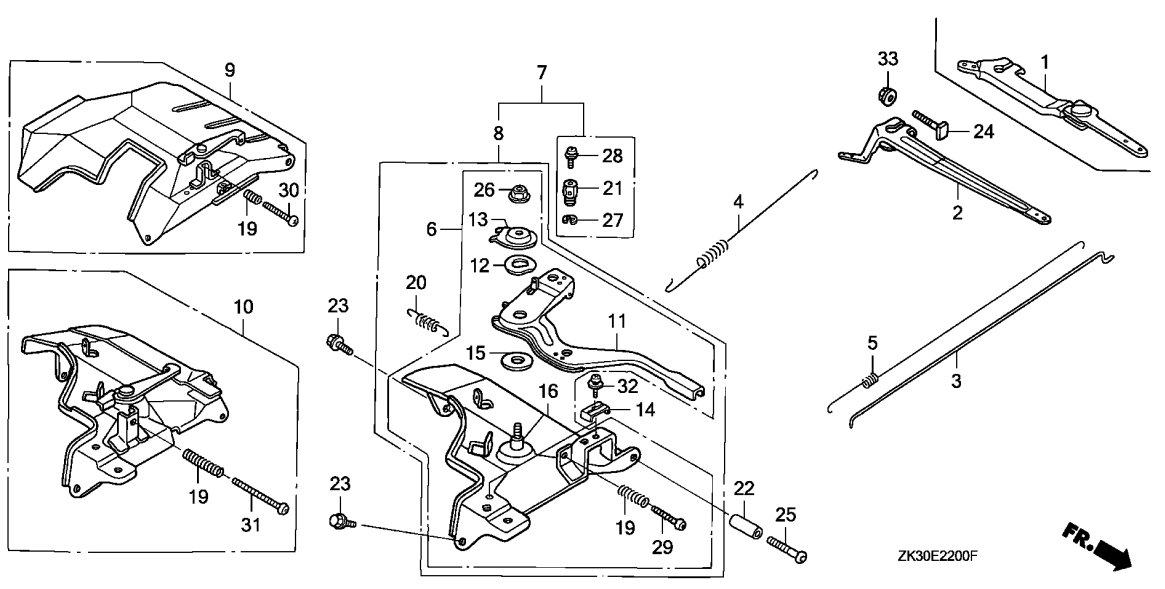

Ref. No.	Part No.	Description	Reqd. QTY			Serial No.	Parts catalogue code					
			GX	(1)	(2)			(3)				
11	16571-ZE3-W00	LEVER, CONTROL .....	1	-	-	-----	HA,HAQ,HA2,HA2/A,HH,HX,HX2,HX26,HX26/A,LH,LH/A,LHB1,LHB3,LHB3/A,LHB5,LHC,LHE,LHE/A,LHQ4,LHQ4/A,LHW,LJS,LJS/A,LJS1,LKE,LKE/A,LT,LT/A,LWD,LX,LX/A,LXE,LXE/A,LXE2,LXE2/A,LXE4,LXE4/A,LXE6,LXE8,LXE8/A,LXQ4,LXQ4/A,LXU,LXU/A,LXZ,LX2,LX2/A,LX26,LX26/A,PKT2,PKT2/A,PKT4,PKT4/A,PKX2,PKX4,PKX4/A,PX,PX/A,PXA2,PXE8,PXE8/A,QA,QA2,QA2/A,QA26,QA26/A,QDW9,QDW9/A,QE,QE/A,QH,QH/A,QHB3,QHB3/A,QHB5,QHC,QHE,QHE/A,QHP1,QHP1/A,QHQ4,QHQ4/A,QH2,QKA4,QKA4/A,QME0,QME0/A,QME8,QME8/A,QMH,QMH/A,QMT2,QMT2/A,QNE,QNE2,QNE2/A,QNE6,QNE9,QNE9/A,QNR2,QNR2/A,QNR6,QNR6/A,QN18,QP,QP/A,QPE2,QT,QT/A,QTC2,QTC2/A,QX,QX/A,QXB,QXB/A,QXB7,QXB7/A,QXC,QXC/A,QXC4,QXC4/A,QXC6,QXC6/A,QXC9,QXC9/A,QXE,QXE/A,QXEB,QXE2,QXE4,QXE4/A,QXE6,QXE6/A,QXE8,QXE8/A,QXQ4,QXQ4/A,QXU,QXU/A,QX2,SE,SE/A,SH,SH/A,SHB1,SHB3,SHB3/A,SHE,SHEZ,SHQ4,SHQ4/A,SHT,SMEO,SMEO/A,SME2,SMX2,SMX2/A,SWX,SWX/A,SX,SX/A,SXB,SXB/A,SXB7,SXB7/A,SXE,SXE/A,SXEB,SXEB/A,SXE2,SXE4,SXE4/A,SXE8,SXE8/A,SXP,SXQ4,SXQ4/A,SXU,SXU/A,VA,VAA,VAAE,VA2,VA2/A,VDE,VDE2,VDE2/A,VD16,VE,VEB6,VH,VHE,VMX,VX,VX/A,VXA,VXB,VXB/A,VXB2,VXB7,VXB7/A,VXE,VXE/A,VXEB,VXEB/A,VXE2,VXE2/A,VXE4,VXE6,VXE7,VXE7/A,VXQ4,VXQ4/A,VX16,VX16/A	1	-	-	-----	2540276 VAH1,VAH2,VH12,VH22
	16571-ZE3-W10	.....	1	-	-	-----	VAD2,VAD2/A,VNG,VNG1,VNG2					
			-	(1)	-	-----						

Ref. No.	Part No.	Description	Reqd. QTY			Serial No.	Parts catalogue code
			(1)	(2)	(3)		
12	16574-ZE1-000	SPRING, LEVER .....	1	-	-	-----	HA,HAQ,HA2,HA2/A,HH,HX,HX2,HX26,HX26/A,LH,LH/A,LHB1,LHB3,LHB3/A,LHB5,LHC,LHE,LHE/A,LHQ4,LHQ4/A,LHW,LJS,LJS/A,LJS1,LKE,LKE/A,LT,LT/A,LWD,LX,LX/A,LXE,LXE/A,LXE2,LXE2/A,LXE4,LXE4/A,LXE6,LXE8,LXE8/A,LXQ4,LXQ4/A,LXU,LXU/A,LXZ,LX2,LX2/A,LX26,LX26/A,PKT2,PKT2/A,PKT4,PKT4/A,PKX2,PKX4,PKX4/A,PX,PX/A,PXA2,PXE8,PXE8/A,QA,QA2,QA2/A,QA26,QA26/A,QDW9,QDW9/A,QE,QE/A,QH,QH/A,QHB3,QHB3/A,QHB5,QHC,QHE,QHE/A,QHP1,QHP1/A,QHQ4,QHQ4/A,QH2,QKA4,QKA4/A,QMED,QMED/A,QME8,QME8/A,QMH,QMH/A,QMT2,QMT2/A,QNE,QNE2,QNE2/A,QNE6,QNE9,QNE9/A,QNR2,QNR2/A,QNR6,QNR6/A,QN18,QP,QP/A,QPE2,QT,QT/A,QTC2,QTC2/A,QX,QX/A,QXB,QXB/A,QXB7,QXB7/A,QXC,QXC/A,QXC4,QXC4/A,QXC6,QXC6/A,QXC9,QXC9/A,QXE,QXE/A,QXEB,QXE2,QXE4,QXE4/A,QXE6,QXE6/A,QXE8,QXE8/A,QXQ4,QXQ4/A,QXU,QXU/A,QX2,SE,SE/A,SH,SH/A,SHB1,SHB3,SHB3/A,SHE,SHEZ,SHQ4,SHQ4/A,SHT,SMED,SMED/A,SME2,SMX2,SMX2/A,SWX,SWX/A,SX,SX/A,SXB,SXB/A,SXB7,SXB7/A,SXE,SXE/A,SXEB,SXEB/A,SXE2,SXE4,SXE4/A,SXE8,SXE8/A,SXP,SXQ4,SXQ4/A,SXU,SXU/A,VA,VAA,VAAE,VAD2,VAD2/A,VA2,VA2/A,VDE,VDE2,VDE2/A,VD16,VE,VEB6,VH,VHE,VMX,VNG,VNG1,VNG2,VX,VX/A,VXA,VXB,VXB/A,VXB2,VXB7,VXB7/A,VXE,VXE/A,VXEB,VXEB/A,VXE2,VXE2/A,VXE4,VXE6,VXE7,VXE7/A,VXQ4,VXQ4/A,VX16,VX16/A
			1	-	-	-----	2540276 VAH1,VAH2,VH12,VH22
			-	(1)	1	-----	
13	16575-ZE2-W00	WASHER, CONTROL LEVER .....	1	-	-	-----	HA,HAQ,HA2,HA2/A,HH,HX,HX2,HX26,HX26/A,LH,LH/A,LHB1,LHB3,LHB3/A,LHB5,LHC,LHE,LHE/A,LHQ4,LHQ4/A,LHW,LJS,LJS/A,LJS1,LKE,LKE/A,LT,LT/A,LWD,LX,LX/A,LXE,LXE/A,LXE2,LXE2/A,LXE4,LXE4/A,LXE6,LXE8,LXE8/A,LXQ4,LXQ4/A,LXU,LXU/A,LXZ,LX2,LX2/A,LX26,LX26/A,PKT2,PKT2/A,PKT4,PKT4/A,PKX2,PKX4,PKX4/A,PX,PX/A,PXA2,PXE8,PXE8/A,QA,QA2,QA2/A,QA26,QA26/A,QDW9,QDW9/A,QE,QE/A,QH,QH/A,QHB3,QHB3/A,QHB5,QHC,QHE,QHE/A,QHP1,QHP1/A,QHQ4,QHQ4/A,QH2,QKA4,QKA4/A,QMED,QMED/A,QME8,QME8/A,QMH,QMH/A,QMT2,QMT2/A,QNE,QNE2,QNE2/A,QNE6,QNE9,QNE9/A,QNR2,QNR2/A,QNR6,QNR6/A,QN18,QP,QP/A,QPE2,QT,QT/A,QTC2,QTC2/A,QX,QX/A,QXB,QXB/A,QXB7,QXB7/A,QXC,QXC/A,QXC4,QXC4/A,QXC6,QXC6/A,QXC9,QXC9/A,QXE,QXE/A,QXEB,QXE2,QXE4,QXE4/A,QXE6,QXE6/A,QXE8,QXE8/A,QXQ4,QXQ4/A,QXU,QXU/A,QX2,SE,SE/A,SH,SH/A,SHB1,SHB3,SHB3/A,SHE,SHEZ,SHQ4,SHQ4/A,SHT,SMED,SMED/A,SME2,SMX2,SMX2/A,SWX,SWX/A,SX,SX/A,SXB,SXB/A,SXB7,SXB7/A,SXE,SXE/A,SXEB,SXEB/A,SXE2,SXE4,SXE4/A,SXE8,SXE8/A,SXP,SXQ4,SXQ4/A,SXU,SXU/A,VA,VAA,VAAE,VAD2,VAD2/A,VA2,VA2/A,VDE,VDE2,VDE2/A,VD16,VE,VEB6,VH,VHE,VMX,VNG,VNG1,VNG2,VX,VX/A,VXA,VXB,VXB/A,VXB2,VXB7,VXB7/A,VXE,VXE/A,VXEB,VXEB/A,VXE2,VXE2/A,VXE4,VXE6,VXE7,VXE7/A,VXQ4,VXQ4/A,VX16,VX16/A
			1	-	-	-----	2540276 VAH1,VAH2,VH12,VH22
			-	(1)	1	-----	



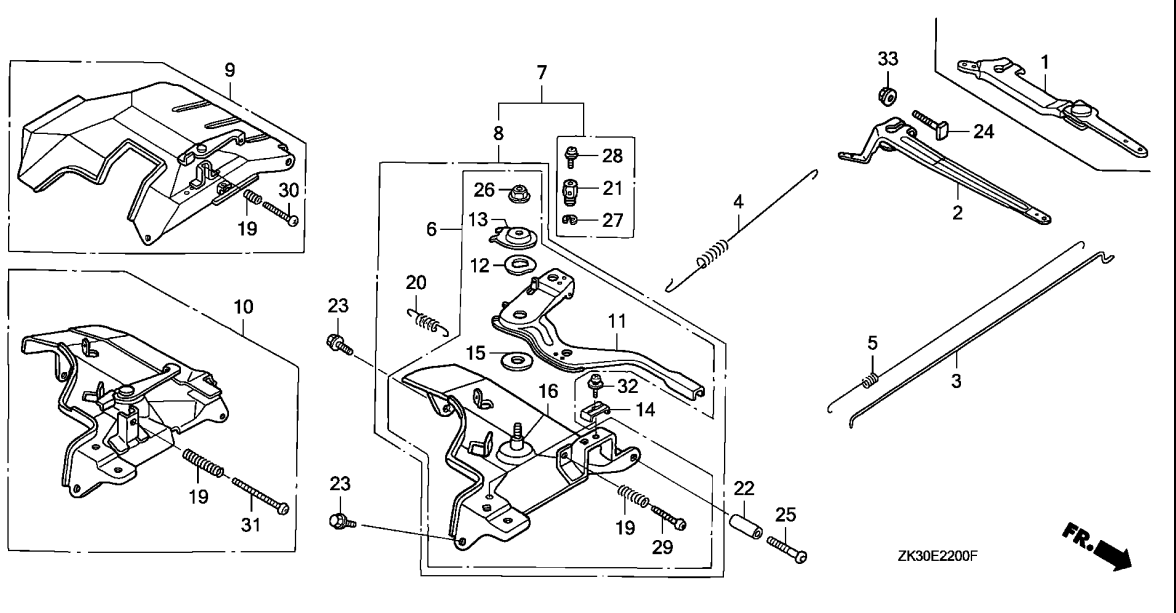

Ref. No.	Part No.	Description	Reqd. QTY			Serial No.	Parts catalogue code
			GX	(1)	(2)		
14	16576-891-000	HOLDER, CABLE .....	1	-	-	-----	HA,HAQ,HA2,HA2/A,HH,HX,HX2,HX26,HX26/A,LH,LH/A,LHB1,LHB3,LHB3/A,LHB5,LHC,LHE,LHE/A,LHQ4,LHQ4/A,LHW,LJS,LJS/A,LJS1,LKE,LKE/A,LT,LT/A,LWD,LX,LX/A,LXE,LXE/A,LXE2,LXE2/A,LXE4,LXE4/A,LXE6,LXE8,LXE8/A,LXQ4,LXQ4/A,LXU,LXU/A,LXZ,LX2,LX2/A,LX26,LX26/A,PX,PX/A,PXE8,PXE8/A,QA,QAE,QAE2,QAE2/A,QAE6,QAE6/A,QAP,QAPE,QAP2,QAP2/A,QAQ,QA2,QA2/A,QA26,QA26/A,QDW9,QDW9/A,QE,QE/A,QH,QH/A,QHB3,QHB3/A,QHB5,QHC,QHE,QHE/A,QHP1,QHP1/A,QHQ4,QHQ4/A,QH2,QKA4,QKA4/A,QMEO,QMEO/A,QME8,QME8/A,QMH,QMH/A,QMT2,QMT2/A,QNE,QNE2,QNE2/A,QNE6,QNE9,QNE9/A,QNR2,QNR2/A,QNR6,QNR6/A,QN18,QP,QP/A,QPE2,QT,QT/A,QTC2,QTC2/A,QX,QX/A,QXB,QXB/A,QXB7,QXB7/A,QXC,QXC/A,QXC4,QXC4/A,QXC6,QXC6/A,QXC9,QXC9/A,QXE,QXE/A,QXEB,QXE2,QXE4,QXE4/A,QXE6,QXE6/A,QXE8,QXE8/A,QXQ4,QXQ4/A,QXU,QXU/A,QX2,SE,SE/A,SH,SH/A,SHB1,SHB3,SHB3/A,SHE,SHEZ,SHQ4,SHQ4/A,SHT,SME0,SME0/A,SME2,SMX2,SMX2/A,SWX,SWX/A,SX,SX/A,SXB,SXB/A,SXB7,SXB7/A,SXE,SXE/A,SXEB,SXEB/A,SXE2,SXE4,SXE4/A,SXE8,SXE8/A,SXP,SXQ4,SXQ4/A,SXU,SXU/A,VA,VA2,VA2/A
			1	-	-	-----	2540276 VAH1,VH12
			-	(1)	-	-----	

Ref. No.	Part No.	Description	Reqd. QTY			Serial No.	Parts catalogue code
			(1)	(2)	(3)		
15	16578-ZE1-000	SPACER, CONTROL LEVER .....	1	-	-	-----	HA,HAQ,HA2,HA2/A,HH,HX,HX2,HX26,HX26/A,LH,LH/A,LHB1,LHB3,LHB3/A,LHB5,LHC,LHE,LHE/A,LHQ4,LHQ4/A,LHW,LJS,LJS/A,LJS1,LKE,LKE/A,LT,LT/A,LWD,LX,LX/A,LXE,LXE/A,LXE2,LXE2/A,LXE4,LXE4/A,LXE6,LXE8,LXE8/A,LXQ4,LXQ4/A,LXU,LXU/A,LXZ,LX2,LX2/A,LX26,LX26/A,PKT2,PKT2/A,PKT4,PKT4/A,PKX2,PKX4,PKX4/A,PX,PX/A,PXA2,PXE8,PXE8/A,QA,QA2,QA2/A,QA26,QA26/A,QDW9,QDW9/A,QE,QE/A,QH,QH/A,QHB3,QHB3/A,QHB5,QHC,QHE,QHE/A,QHP1,QHP1/A,QHQ4,QHQ4/A,QH2,QKA4,QKA4/A,QMED,QMED/A,QME8,QME8/A,QMH,QMH/A,QMT2,QMT2/A,QNE,QNE2,QNE2/A,QNE6,QNE9,QNE9/A,QNR2,QNR2/A,QNR6,QNR6/A,QN18,QP,QP/A,QPE2,QT,QT/A,QTC2,QTC2/A,QX,QX/A,QXB,QXB/A,QXB7,QXB7/A,QXC,QXC/A,QXC4,QXC4/A,QXC6,QXC6/A,QXC9,QXC9/A,QXE,QXE/A,QXEB,QXE2,QXE4,QXE4/A,QXE6,QXE6/A,QXE8,QXE8/A,QXQ4,QXQ4/A,QXU,QXU/A,QX2,SE,SE/A,SH,SH/A,SHB1,SHB3,SHB3/A,SHE,SHEZ,SHQ4,SHQ4/A,SHT,SME0,SME0/A,SME2,SMX2,SMX2/A,SWX,SWX/A,SX,SX/A,SXB,SXB/A,SXB7,SXB7/A,SXE,SXE/A,SXEB,SXEB/A,SXE2,SXE4,SXE4/A,SXE8,SXE8/A,SXP,SXQ4,SXQ4/A,SXU,SXU/A,VA,VAA,VAE,VAE2,VAE2/A,VA2,VA2/A,VDE,VDE2,VDE2/A,VD16,VE,VEB6,VH,VHE,VMX,VNG,VNG1,VNG2,VX,VX/A,VXA,VXB,VXB/A,VXB2,VXB7,VXB7/A,VXE,VXE/A,VXEB,VXEB/A,VXE2,VXE2/A,VXE4,VXE6,VXE7,VXE7/A,VXQ4,VXQ4/A,VX16,VX16/A
			1	-	-	-----	2540276 VAH1,VAH2,VH12,VH22
			-	(1)	1		
16	16581-ZE3-W00	BASE COMP., CONTROL (###) ...	1	-	-	-----	HA,HAQ,HA2,HA2/A,HH,HX,HX2,HX26,HX26/A,LH,LH/A,LHB1,LHB3,LHB3/A,LHB5,LHC,LHE,LHE/A,LHQ4,LHQ4/A,LHW,LJS,LJS/A,LJS1,LKE,LKE/A,LP,LT,LT/A,LWD,LX,LX/A,LXE,LXE/A,LXE2,LXE2/A,LXE4,LXE4/A,LXE6,LXE8,LXE8/A,LXQ4,LXQ4/A,LXU,LXU/A,LXZ,LX2,LX2/A,LX26,LX26/A,PKT2,PKT2/A,PKT4,PKT4/A,PKX2,PKX4,PKX4/A,PX,PX/A,PXA2,PXE8,PXE8/A,QA,QA2,QA2/A,QA26,QA26/A,QDW9,QDW9/A,QE,QE/A,QH,QH/A,QHB3,QHB3/A,QHB5,QHC,QHE,QHE/A,QHP1,QHP1/A,QHQ4,QHQ4/A,QH2,QKA4,QKA4/A,QMED,QMED/A,QME8,QME8/A,QMH,QMH/A,QMT2,QMT2/A,QNE,QNE2,QNE2/A,QNE6,QNE9,QNE9/A,QNR2,QNR2/A,QNR6,QNR6/A,QN18,QP,QP/A,QPE2,QT,QT/A,QTC2,QTC2/A,QX,QX/A,QXB,QXB/A,QXB7,QXB7/A,QXC,QXC/A,QXC4,QXC4/A,QXC6,QXC6/A,QXC9,QXC9/A,QXE,QXE/A,QXEB,QXE2,QXE4,QXE4/A,QXE6,QXE6/A,QXE8,QXE8/A,QXQ4,QXQ4/A,QXU,QXU/A,QX2,SE,SE/A,SH,SH/A,SHB1,SHB3,SHB3/A,SHE,SHEZ,SHQ4,SHQ4/A,SHT,SME0,SME0/A,SME2,SMX2,SMX2/A,SWX,SWX/A,SX,SX/A,SXB,SXB/A,SXB7,SXB7/A,SXE,SXE/A,SXEB,SXEB/A,SXE2,SXE4,SXE4/A,SXE8,SXE8/A,SXP,SXQ4,SXQ4/A,SXU,SXU/A,VA,VAA,VAE,VAE2,VAE2/A,VA2,VA2/A,VDE,VDE2,VDE2/A,VD16,VE,VEB6,VH,VHE,VMX,VNG,VNG1,VNG2,VX,VX/A,VXA,VXB,VXB/A,VXB2,VXB7,VXB7/A,VXE,VXE/A,VXEB,VXEB/A,VXE2,VXE2/A,VXE4,VXE6,VXQ4,VXQ4/A,VX16,VX16/A
			1	-	-	-----	2540276 VAH1,VAH2,VH12,VH22
			-	(1)	1		



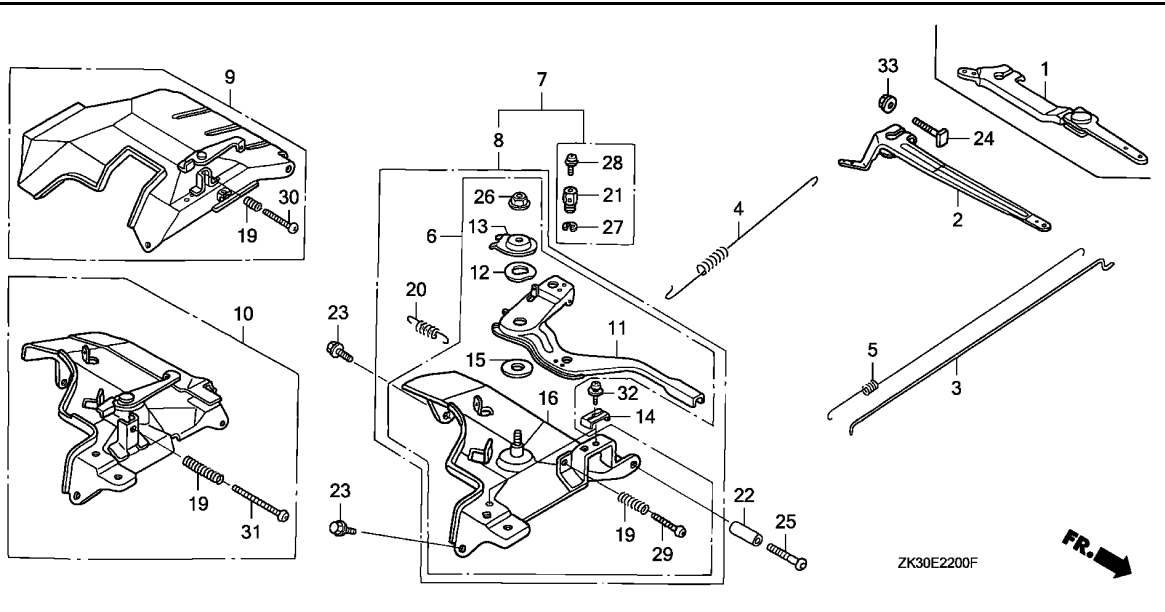

Ref. No.	Part No.	Description	Reqd. QTY GX 340K1 (1) (2) (3)	Serial No.	Parts catalogue code
19	16584-883-300	SPRING, CONTROL ADJUSTING ...	1	-	EDE2,EDE2/A,EDK,EDN,EDN2,EDN2/A,EDN5,EDN5/A,EDS,EDS3,EDS4,EDS6 EDS6/A,EDT3,EDT6,EDT6/A,ED6,ED6/A,ED7,ED8,ED8/A,ED9,ED9/A,EMT EMT/A,EN,ENT2,EN6,EN6/A,ES,ES1,ES1/A,ES2,ES3,ES3/A,ES4,ES4/A,ET ETS,ETX,HA,HAQ,HA2,HA2/A,HH,HX,HX2,HX26,HX26/A,LH,LH/A,LHB1,LHB3 LHB3/A,LHB5,LHC,LHE,LHE/A,LHQ4,LHQ4/A,LHW,LJS,LJS/A,LJS1,LKE LKE/A,LT,LT/A,LWD,LX,LX/A,LXE,LXE/A,LXE2,LXE2/A,LXE4,LXE4/A,LXE6 LXE8,LXE8/A,LXQ4,LXQ4/A,LXU,LXU/A,LXZ,LX2,LX2/A,LX26,LX26/A,PKT2 PKT2/A,PKT4,PKT4/A,PKX2,PKX4,PKX4/A,PX,PX/A,PXA2,PXE8,PXE8/A,QA QAE,QAE2,QAE2/A,QAE6,QAE6/A,QAP,QAPE,QAP2,QAP2/A,QAQ,QA2,QA2/A QA26,QA26/A,QDW9,QDW9/A,QE,QE/A,QH,QH/A,QHB3,QHB3/A,QHB5,QHC,QHE QHE/A,QHP1,QHP1/A,QHQ4,QHQ4/A,QH2,QKA4,QKA4/A,QMEO,QMEO/A,QME8 QME8/A,QMH,QMH/A,QMT2,QMT2/A,QNE,QNE2,QNE2/A,QNE6,QNE9,QNE9/A QNR2,QNR2/A,QNR6,QNR6/A,QN18,QP,QP/A,QPE2,QT,QT/A,QTC2,QTC2/A,QX QX/A,QXB,QXB/A,QXB7,QXB7/A,QXC,QXC/A,QXC4,QXC4/A,QXC6,QXC6/A,QXC9 QXC9/A,QXE,QXE/A,QXEB,QXE2,QXE4,QXE4/A,QXE6,QXE6/A,QXE8,QXE8/A QXQ4,QXQ4/A,QXU,QXU/A,QX2,SE,SE/A,SH,SH/A,SHB1,SHB3,SHB3/A,SHE SHEZ,SHQ4,SHQ4/A,SHT,SMEO,SMEO/A,SME2,SMX2,SMX2/A,SWX,SWX/A,SX SX/A,SXB,SXB/A,SXB7,SXB7/A,SXE,SXE/A,SXEB,SXEB/A,SXE2,SXE4,SXE4/A SXEB,SXEB/A,SXP,SXQ4,SXQ4/A,SXU,SXU/A,VA,VAA,VAAE,VAD2,VAD2/A VAH1,VAH2,VAW1,VA2,VA2/A,VC2,VC2/A,VDE,VDE2,VDE2/A,VD16,VE,VEB6 VH,VHE,VH12,VH12/A,VH22,VH22/A,VMQ,VMT,VMT/A,VMX,VNG,VNG1,VNG2 VSH7,VS2,VS3,VS4,VS5,VS6,VS7,VTE2,VWA,VWA2,VWC,VWC2,VWC2/A,VWE VWE2,VWE2/A,VWS2,VWS2/A,VW12,VW12/A,VX,VX/A,VXA,VXB,VXB/A,VXB2 VXB7,VXB7/A,VXE,VXE/A,VXEB,VXEB/A,VXE2,VXE2/A,VXE4,VXE6,VXE7 VXE7/A,VXE8,VXE8/A,VXG,VXK,VXQ4,VXQ4/A,VXU,VXU/A,VXU1,VXU1/A,VX16 VX16/A,VX8,VX8/A
			(1)		

- (1) 1

Ref. No.	Part No.	Description	Reqd. QTY			Serial No.	Parts catalogue code
			(1)	(2)	(3)		
20	16592-883-310	SPRING, CABLE RETURN .....	1	-	-	-----	HA,HAQ,HA2,HA2/A,HH,HX,HX2,HX26,HX26/A,LH,LH/A,LHB1,LHB3,LHB3/A,LHB5,LHC,LHE,LHE/A,LHQ4,LHQ4/A,LHW,LJS,LJS/A,LJS1,LKE,LKE/A,LT,LT/A,LWD,LX,LX/A,LXE,LXE/A,LXE2,LXE2/A,LXE4,LXE4/A,LXE6,LXE8,LXE8/A,LXQ4,LXQ4/A,LXU,LXU/A,LXZ,LX2,LX2/A,LX26,LX26/A,PX,PX/A,PXE8,PXE8/A,QA,QAE,QAE2,QAE2/A,QAE6,QAE6/A,QAP,QAPE,QAP2,QAP2/A,QAQ,QA2,QA2/A,QA26,QA26/A,QDW9,QDW9/A,QE,QE/A,QH,QH/A,QHB3,QHB3/A,QHB5,QHC,QHE,QHE/A,QHP1,QHP1/A,QHQ4,QHQ4/A,QH2,QKA4,QKA4/A,QMEO,QMEO/A,QME8,QME8/A,QMH,QMH/A,QMT2,QMT2/A,QNE,QNE2,QNE2/A,QNE6,QNE9,QNE9/A,QNR2,QNR2/A,QNR6,QNR6/A,QN18,QP,QP/A,QPE2,QT,QT/A,QTC2,QTC2/A,QX,QX/A,QXB,QXB/A,QXB7,QXB7/A,QXC,QXC/A,QXC4,QXC4/A,QXC6,QXC6/A,QXC9,QXC9/A,QXE,QXE/A,QXEB,QXE2,QXE4,QXE4/A,QXE6,QXE6/A,QXE8,QXE8/A,QXQ4,QXQ4/A,QXU,QXU/A,QX2,SE,SE/A,SH,SH/A,SHB1,SHB3,SHB3/A,SHE,SHEZ,SHQ4,SHQ4/A,SHT,SME0,SME0/A,SME2,SMX2,SMX2/A,SWX,SWX/A,SX,SX/A,SXB,SXB/A,SXB7,SXB7/A,SXE,SXE/A,SXEB,SXEB/A,SXE2,SXE4,SXE4/A,SXE8,SXE8/A,SXP,SXQ4,SXQ4/A,SXU,SXU/A,VA,VA2,VA2/A
			1	-	-	-----	2540276 VAH1,VH12
			-	(1)	-	-----	
21	16594-883-010	HOLDER, WIRE .....	1	-	-	-----	LHW,LJS,LJS/A,LJS1,LKE,LKE/A,LT,LT/A,LWD,QAP,QAPE,QAP2,QAP2/A,QDW9,QDW9/A,QKA4,QKA4/A,QPE2,QTC2,QTC2/A,SME2,SMX2,SMX2/A,SXP
			-	(1)	-	-----	
22	16599-ZG1-M10	COLLAR, STOPPER .....	(1)	-	(1)	-----	LHQ4,LHQ4/A,LKE/A,LXE4,LXE4/A,LXQ4,LXQ4/A,PKT4,PKT4/A,PKX4,PKX4/A,QE/A,QHQ4,QHQ4/A,QKA4,QKA4/A,QMEO,QMEO/A,QME8,QME8/A,QXB/A,QXB7,QXB7/A,QXC4,QXC4/A,QXE4,QXE4/A,QXQ4,QXQ4/A,SE/A,SHQ4,SHQ4/A,SME0,SME0/A,SXB/A,SXB7,SXB7/A,SXEB/A,SXE4,SXE4/A,SXQ4,SXQ4/A,VD16,VEB6,VSH7,VXB/A,VXB7,VXB7/A,VXEB/A,VXE4,VXE7,VXE7/A,VXQP,VXQ4,VXQ4/A,QE,QXB,SE,SXB,SXEB,VNG1,VNG2,VXB,VXEB,VXG
			(1)	-	-	-----	2337465 -----
			(1)	-	-	-----	2398545 -----
23	90013-883-000	BOLT, FLANGE, 6X12(CT200) ...	2	-	-	-----	LKE EDE2,EDE2/A,EDK,EDN2,EDN2/A,EDN5,EDN5/A,EDS,EDS3,EDS4,EDS6,EDS6/A,EDT3,EDT6,EDT6/A,ED6,ED6/A,ED7,ED8,ED8/A,ED9,ED9/A,EMT,EMT/A,EN,ENT2,EN6,EN6/A,ES,ES1,ES1/A,ES2,ES3,ES3/A,ES4,ES4/A,ET,ETX,HA,HAQ,HA2,HA2/A,HH,HX,HX2,HX26,HX26/A,LH,LH/A,LHB1,LHB3,LHB3/A,LHB5,LHC,LHE,LHE/A,LHQ4,LHQ4/A,LHW,LJS,LJS/A,LJS1,LKE,LKE/A,LP,LT,LT/A,LWD,LX,LX/A,LXE,LXE/A,LXE2,LXE2/A,LXE4,LXE4/A,LXE6,LXE8,LXE8/A,LXQ4,LXQ4/A,LXU,LXU/A,LXZ,LX2,LX2/A,LX26,LX26/A,PKT2,PKT2/A,PKT4,PKT4/A,PKX2,PKX4,PKX4/A,PX,PX/A,PXA2,PXE8,PXE8/A,QA,QAE,QAE2,QAE2/A,QAE6,QAE6/A,QAP,QAPE,QAP2,QAP2/A,QAQ,QA2,QA2/A,QA26,QA26/A,QDW9,QDW9/A,QE,QE/A,QH,QH/A,QHB3,QHB3/A,QHB5,QHC,QHE,QHE/A,QHP1,QHP1/A,QHQ4,QHQ4/A,QH2,QKA4,QKA4/A,QMEO,QMEO/A,QME8,QME8/A,QMH,QMH/A,QMT2,QMT2/A,QNE,QNE2,QNE2/A,QNE6,QNE9,QNE9/A,QNR2,QNR2/A,QNR6,QNR6/A,QN18,QP,QP/A,QPE2,QT,QT/A,QTC2,QTC2/A,QX,QX/A,QXB,QXB/A,QXB7,QXB7/A,QXC,QXC/A,QXC4,QXC4/A,QXC6,QXC6/A,QXC9,QXC9/A,QXE,QXE/A,QXEB,QXE2,QXE4,QXE4/A,QXE6,QXE6/A,QXE8,QXE8/A,QXQ4,QXQ4/A,QXU,QXU/A,QX2,SE,SE/A,SH,SH/A,SHB1,SHB3,SHB3/A,SHE,SHEZ,SHQ4,SHQ4/A,SHT,SME0,SME0/A,SME2,SMX2,SMX2/A,SWX,SWX/A,SX,SX/A,SXB,SXB/A,SXB7,SXB7/A,SXE,SXE/A,SXEB,SXEB/A,SXE2,SXE4,SXE4/A,SXE8,SXE8/A,SXP,SXQ4,SXQ4/A,SXU,SXU/A,VA,VAA,VAEA,VAD2,VAD2/A,VAH1,VAH2,VAW1,VA2,VA2/A,VC2,VC2/A,VDE,VDE2,VDE2/A,VD16,VE,VEB6,VH,VHE,VH12,VH12/A,VH22,VH22/A,VMQ,VMT,VMT/A,VMX,VNG,VNG1,VNG2,VSH7,VS2,VS3,VS4,VS5,VS6,VS7,VTE2,VMA,VMA2,VWC,VWC2,VWC2/A,VWE,VWE2,VWE2/A,VWS2,VWS2/A,VW12,VW12/A,VX,VX/A,VXA,VXB,VXB/A,VXB2,VXB7,VXB7/A,VXE,VXE/A,VXEB,VXEB/A,VXE2,VXE2/A,VXE4,VXE6,VXE7,VXE7/A,VXE8,VXE8/A,VXG,VXK,VXQ4,VXQ4/A,VXU,VXU/A,VXU1,VXU1/A,VX16,VX16/A,VX8,VX8/A
			-	2	2	-----	



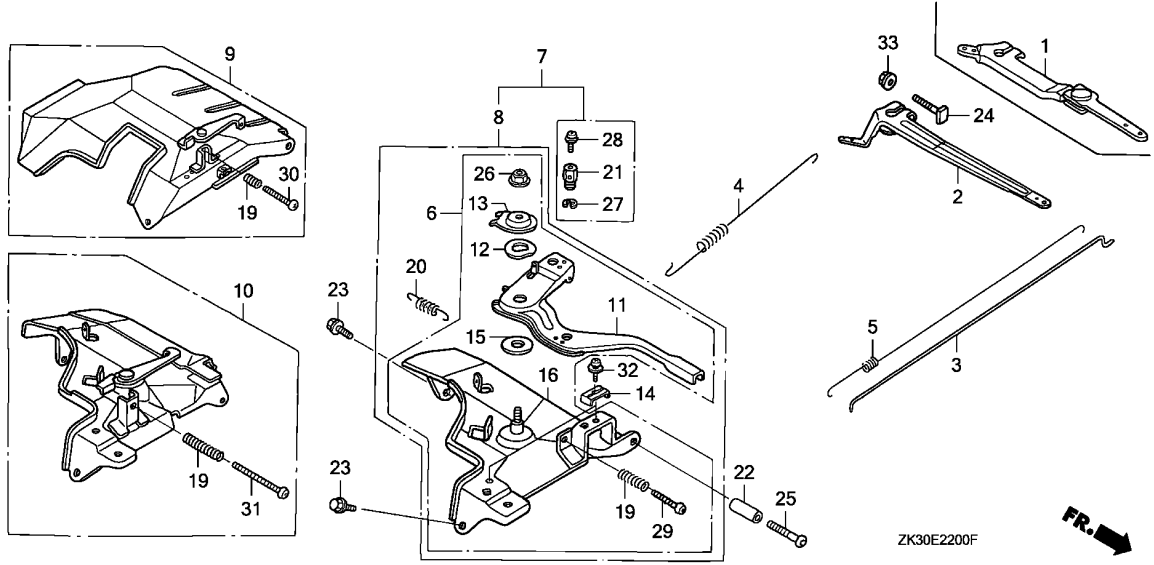

ZK30E2200F

Ref. No.	Part No.	Description	Reqd. QTY GX 340K1 (1) (2) (3)	Serial No.	Parts catalogue code
24	90015-ZE5-010	BOLT, GOVERNOR ARM	1		EDE2,EDE2/A,EDK,EDN,EDN2,EDN2/A,EDN5,EDN5/A,EDS,EDS3,EDS4,EDS5 EDS6,EDS6/A,EDT3,EDT6,EDT6/A,ED6,ED6/A,ED7,ED8,ED8/A,ED9,ED9/A EMT,EMT/A,EN,ENT2,EN6,EN6/A,ES,ES1,ES1/A,ES2,ES3,ES3/A,ES4,ES4/A ET,ETS,ETX,HA,HAQ,HA2,HA2/A,HH,HX,HX2,HX26,HX26/A,LH,LH/A,LHB1 LHB3,LHB3/A,LHB5,LHC,LHE,LHE/A,LHQ4,LHQ4/A,LHW,LJS,LJS/A,LJS1,LKE LKE/A,LT,LT/A,LWD,LX,LX/A,LXE,LXE/A,LXE2,LXE2/A,LXE4,LXE4/A,LXE6 LXE8,LXE8/A,LXQ4,LXQ4/A,LXU,LXU/A,LXZ,LX2,LX2/A,LX26,LX26/A,PKT2 PKT2/A,PKT4,PKT4/A,PKX2,PKX4,PKX4/A,PX,PX/A,PXA2,PXE8,PXE8/A,QA QAE,QAE2,QAE2/A,QAE6,QAE6/A,QAP,QAPE,QAP2,QAP2/A,QAQ,QA2,QA2/A QA26,QA26/A,QDW9,QDW9/A,QE,QE/A,QH,QH/A,QHB3,QHB3/A,QHB5,QHC,QHE QHE/A,QHP1,QHP1/A,QHQ4,QHQ4/A,QH2,QKA4,QKA4/A,QMED,QMED/A,QME8 QME8/A,QMH,QMH/A,QMT2,QMT2/A,QNE,QNE2,QNE2/A,QNE6,QNE9,QNE9/A QNR2,QNR2/A,QNR6,QNR6/A,QN18,QP,QP/A,QPE2,QT,QT/A,QTC2,QTC2/A,QX QX/A,QXB,QXB/A,QXB7,QXB7/A,QXC,QXC/A,QXC4,QXC4/A,QXC6,QXC6/A,QXC9 QXC9/A,QXE,QXE/A,QXEB,QXE2,QXE4,QXE4/A,QXE6,QXE6/A,QXE8,QXE8/A QXQ4,QXQ4/A,QXU,QXU/A,QX2,SE,SE/A,SH,SH/A,SHB1,SHB3,SHB3/A,SHE SHEZ,SHQ4,SHQ4/A,SHT,SMEO,SMEO/A,SME2,SMX2,SMX2/A,SWX,SWX/A,SX SX/A,SXB,SXB/A,SXB7,SXB7/A,SXE,SXE/A,SXEB,SXEB/A,SXE2,SXE4,SXE4/A SXEB,SXEB/A,SXP,SXQ4,SXQ4/A,SXU,SXU/A,VA,VAA,VAEA,VAD2,VAD2/A VAH1,VAH2,VAW1,VA2,VA2/A,VC2,VC2/A,VDE,VDE2,VDE2/A,VD16,VE,VEB6 VH,VHE,VH12,VH12/A,VH22,VH22/A,VMQ,VMT,VMT/A,VMX,VNG,VNG1,VNG2 VSH7,VS2,VS3,VS4,VS5,VS6,VS7,VTE2,VWA,VWA2,VWC,VWC2,VWC2/A,VWE VWE2,VWE2/A,VWS2,VWS2/A,VW12,VW12/A,VX,VX/A,VXA,VXB,VXB/A,VXB2 VXB7,VXB7/A,VXE,VXE/A,VXEB,VXEB/A,VXE2,VXE2/A,VXE4,VXE6,VXE7 VXE7/A,VXE8,VXE8/A,VXG,VXK,VXQ4,VXQ4/A,VXU,VXU/A,VXU1,VXU1/A,VX16 VX16/A,VX8,VX8/A
			- 1 1		

2



Ref. No.	Part No.	Description	Reqd. QTY			Serial No.	Parts catalogue code
			(1)	(2)	(3)		
25	90016-ZG9-N30	SCREW, RECESSED, 5X25 .....	(1)	-	(1)		LHQ4, LHQ4/A, LKE/A, LXE4, LXE4/A, LXQ4, LXQ4/A, PKT4, PKT4/A, PKX4, PKX4/A, QE/A, QHQ4, QHQ4/A, QKA4, QKA4/A, QMEO, QMEO/A, QME8, QME8/A, QXB/A, QXB7, QXB7/A, QXC4, QXC4/A, QXE4, QXE4/A, QXQ4, QXQ4/A, SE/A, SHQ4, SHQ4/A, SMEO, SMEO/A, SXB/A, SXB7, SXB7/A, SXEB/A, SXE4, SXE4/A, SXQ4, SXQ4/A, VD16, VEB6, VSH7, VXB/A, VXB7, VXB7/A, VXEB/A, VXE4, VXE7, VXE7/A, VXQP, VXQ4, VXQ4/A, QE, QXB, SE, SXB, SXEB, VNG1, VNG2, VXB, VXEB, VXG
			(1)	-	-	2337465	LKE
			(1)	-	-	2398545	LKE
26	90114-SAO-000	NUT, SELF-LOCK, 6MM .....	1	-	-		HA, HAQ, HA2, HA2/A, HH, HX, HX2, HX26, HX26/A, LH, LH/A, LHB1, LHB3, LHB3/A, LHB5, LHC, LHE, LHE/A, LHQ4, LHQ4/A, LHW, LJS, LJS/A, LJS1, LKE, LKE/A, LT, LT/A, LWD, LX, LX/A, LXE, LXE/A, LXE2, LXE2/A, LXE4, LXE4/A, LXE6, LXE8, LXE8/A, LXQ4, LXQ4/A, LXU, LXU/A, LXZ, LX2, LX2/A, LX26, LX26/A, PKT2, PKT2/A, PKT4, PKT4/A, PKX2, PKX4, PKX4/A, PX, PX/A, PXA2, PXE8, PXE8/A, QA, QAE, QAE2, QAE2/A, QAE6, QAE6/A, QAP, QAPE, QAP2, QAP2/A, QAQ, QA2, QA2/A, QA26, QA26/A, QDW9, QDW9/A, QE, QE/A, QH, QH/A, QHB3, QHB3/A, QHB5, QHC, QHE, QHE/A, QHP1, QHP1/A, QHQ4, QHQ4/A, QH2, QKA4, QKA4/A, QMEO, QMEO/A, QME8, QME8/A, QMH, QMH/A, QMT2, QMT2/A, QNE, QNE2, QNE2/A, QNE6, QNE9, QNE9/A, QNR2, QNR2/A, QNR6, QNR6/A, QN18, QP, QP/A, QPE2, QT, QT/A, QTC2, QTC2/A, QX, QX/A, QXB, QXB/A, QXB7, QXB7/A, QXC, QXC/A, QXC4, QXC4/A, QXC6, QXC6/A, QXC9, QXC9/A, QXE, QXE/A, QXEB, QXE2, QXE4, QXE4/A, QXE6, QXE6/A, QXE8, QXE8/A, QXQ4, QXQ4/A, QXU, QXU/A, QX2, SE, SE/A, SH, SH/A, SHB1, SHB3, SHB3/A, SHE, SHEZ, SHQ4, SHQ4/A, SHT, SMEO, SMEO/A, SME2, SMX2, SMX2/A, SWX, SWX/A, SX, SX/A, SXB, SXB/A, SXB7, SXB7/A, SXE, SXE/A, SXEB, SXEB/A, SXE2, SXE4, SXE4/A, SXE8, SXE8/A, SXP, SXQ4, SXQ4/A, SXU, SXU/A, VA, VAA, VAAE, VAD2, VAD2/A, VA2, VA2/A, VDE, VDE2, VDE2/A, VD16, VE, VEB6, VH, VHE, VMX, VNG, VNG1, VNG2, VX, VX/A, VXA, VXB, VXB/A, VXB2, VXB7, VXB7/A, VXE, VXE/A, VXEB, VXEB/A, VXE2, VXE2/A, VXE4, VXE6, VXE7, VXE7/A, VXQ4, VXQ4/A, VX16, VX16/A
			1	-	-	2540276	VAH1, VAH2, VH12, VH22
			-	(1)	1		
27	90605-230-000	CIRCLIP, 5MM .....	1	-	-		LHW, LJS, LJS/A, LJS1, LKE, LKE/A, LT, LT/A, LWD, QAP, QAPE, QAP2, QAP2/A, QDW9, QDW9/A, QKA4, QKA4/A, QPE2, QTC2, QTC2/A, SME2, SMX2, SMX2/A, SXP
28	93500-04006-0H	SCREW, PAN, 4X6 .....	1	-	-		LHW, LJS, LJS/A, LJS1, LKE, LKE/A, LT, LT/A, LWD, QAP, QAPE, QAP2, QAP2/A, QDW9, QDW9/A, QKA4, QKA4/A, QPE2, QTC2, QTC2/A, SME2, SMX2, SMX2/A, SXP
29	93500-05032-0A	SCREW, PAN, 5X32 .....	1	-	-		HA, HAQ, HA2, HA2/A, HH, HX, HX2, HX26, HX26/A, LH, LH/A, LHB1, LHB3, LHB3/A, LHB5, LHC, LHE, LHE/A, LHQ4, LHQ4/A, LHW, LJS, LJS/A, LJS1, LKE, LKE/A, LT, LT/A, LWD, LX, LX/A, LXE, LXE/A, LXE2, LXE2/A, LXE4, LXE4/A, LXE6, LXE8, LXE8/A, LXQ4, LXQ4/A, LXU, LXU/A, LXZ, LX2, LX2/A, LX26, LX26/A, PKT2, PKT2/A, PKT4, PKT4/A, PKX2, PKX4, PKX4/A, PX, PX/A, PXA2, PXE8, PXE8/A, QA, QAE, QAE2, QAE2/A, QAE6, QAE6/A, QAP, QAPE, QAP2, QAP2/A, QAQ, QA2, QA2/A, QA26, QA26/A, QDW9, QDW9/A, QE, QE/A, QH, QH/A, QHB3, QHB3/A, QHB5, QHC, QHE, QHE/A, QHP1, QHP1/A, QHQ4, QHQ4/A, QH2, QKA4, QKA4/A, QMEO, QMEO/A, QME8, QME8/A, QMH, QMH/A, QMT2, QMT2/A, QNE, QNE2, QNE2/A, QNE6, QNE9, QNE9/A, QNR2, QNR2/A, QNR6, QNR6/A, QN18, QP, QP/A, QPE2, QT, QT/A, QTC2, QTC2/A, QX, QX/A, QXB, QXB/A, QXB7, QXB7/A, QXC, QXC/A, QXC4, QXC4/A, QXC6, QXC6/A, QXC9, QXC9/A, QXE, QXE/A, QXEB, QXE2, QXE4, QXE4/A, QXE6, QXE6/A, QXE8, QXE8/A, QXQ4, QXQ4/A, QXU, QXU/A, QX2, SE, SE/A, SH, SH/A, SHB1, SHB3, SHB3/A, SHE, SHEZ, SHQ4, SHQ4/A, SHT, SMEO, SMEO/A, SME2, SMX2, SMX2/A, SWX, SWX/A, SX, SX/A, SXB, SXB/A, SXB7, SXB7/A, SXE, SXE/A, SXEB, SXEB/A, SXE2, SXE4, SXE4/A, SXE8, SXE8/A, SXP, SXQ4, SXQ4/A, SXU, SXU/A, VA, VAA, VAAE, VAD2, VAD2/A, VA2, VA2/A, VDE, VDE2, VDE2/A, VD16, VE, VEB6, VH, VHE, VMX, VNG, VNG1, VNG2, VX, VX/A, VXA, VXB, VXB/A, VXB2, VXB7, VXB7/A, VXE, VXE/A, VXEB, VXEB/A, VXE2, VXE2/A, VXE4, VXE6, VXE7, VXE7/A, VXQ4, VXQ4/A, VX16, VX16/A
			1	-	-	2540276	VAH1, VAH2, VH12, VH22
			-	(1)	1		



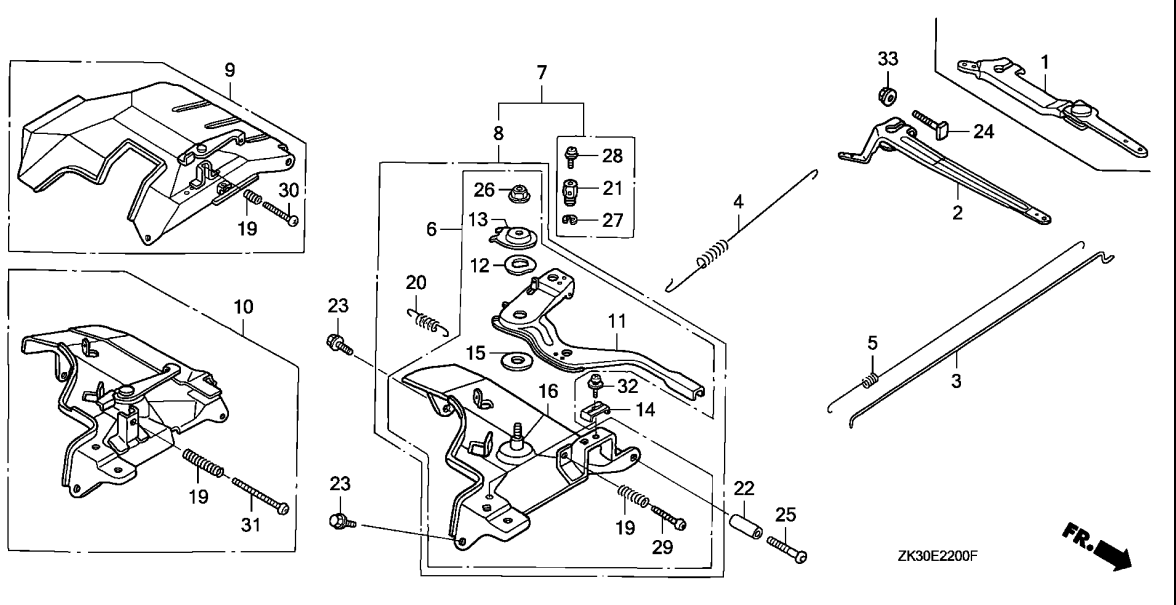

Ref. No.	Part No.	Description	Reqd. QTY			Serial No.	Parts catalogue code
			GX	340K1			
			(1)	(2)	(3)		
30	93500-05035-0A	SCREW, PAN, 5X35	1	-	-	-----	EDE2,EDE2/A,EDN,EDN2,EDN2/A,EDS,EDS3,EDS4,EDS6,EDS6/A,EDT3,EDT6 EDT6/A,ED6,ED6/A,EMT,EMT/A,ENT2,EN6,EN6/A,ES3,ES3/A,ES4,ES4/A,VMQ VMT,VMT/A,VS2,VS3,VS4,VS5,VS6,VS7,VTE2,VWC,VWE
31	93500-05045-0A	SCREW, PAN, 5X45	1	-	-	-----	EDK,EDN5,EDN5/A,ED7,ED8,ED8/A,ED9,ED9/A,EN,ES,ES1,ES1/A,ES2,ET ETS,ETX,VAW1,VC2,VC2/A,VSH7,VWA,VWA2,VWC2,VWC2/A,VWE2,VWE2/A,VWS2 VWS2/A,VW12,VW12/A,VXE8,VXE8/A,VXG,VXK,VXU,VXU/A,VXU1,VXU1/A,VX8 VX8/A
32	93893-05016-00	SCREW-WASHER, 5X16	1	(1)	-	2540277 ----- 2206228	VAH1,VAH2 HA,HAQ,HH,HX,LH,LHC,LHE,LKE,LX,LXE,LXZ,L1,PX,P1,QA,QAE,QAP,QAPE QAQ,QE,QH,QHC,QHE,QNE,QNE9,QP,QT,QX,QXB,QXC,QXE,QXEB,Q1,SE,SH,SHE SHEZ,SWX,SX,SXB,SXE,SXEB,SXP,S1,VA,VAH1,V1

Ref. No.	Part No.	Description	Reqd. QTY			Serial No.	Parts catalogue code
			(1)	(2)	(3)		
32)	93500-05016-0A	SCREW, PAN, 5X16	1	(1)	-	HA2, HA2/A, HX2, HX26, HX26/A, LH/A, LHB1, LHB3, LHB3/A, LHB5, LHE/A, LHQ4, LHQ4/A, LHW, LJS, LJS/A, LJS1, LKE/A, LT, LT/A, LWD, LX/A, LXE/A, LXE2, LXE2/A, LXE4, LXE4/A, LXE6, LXE8, LXE8/A, LXQ4, LXQ4/A, LXU, LXU/A, LX2, LX2/A, LX26, LX26/A, L1/A, PX/A, PXE8, PXE8/A, P1/A, QAE2, QAE2/A, QAE6, QAE6/A, QAP2, QAP2/A, QA2, QA2/A, QA26, QA26/A, QDW9, QDW9/A, QE/A, QH/A, QHB3, QHB3/A, QHB5, QHE/A, QHP1, QHP1/A, QHQ4, QHQ4/A, QH2, QKA4, QKA4/A, QME0, QME0/A, QME8, QME8/A, QMH, QMH/A, QMT2, QMT2/A, QNE2, QNE2/A, QNE6, QNE9/A, QNR2, QNR2/A, QNR6, QNR6/A, QN18, QP/A, QPE2, QT/A, QTC2, QTC2/A, QX/A, QXB/A, QXB7, QXB7/A, QXC/A, QXC4, QXC4/A, QXC6, QXC6/A, QXC9, QXC9/A, QXE/A, QXE2, QXE4, QXE4/A, QXE6, QXE6/A, QXE8, QXE8/A, QXQ4, QXQ4/A, QXU, QXU/A, QX2, Q1/A, SE/A, SH/A, SHB1, SHB3, SHB3/A, SHQ4, SHQ4/A, SHT, SMEO, SMEO/A, SME2, SMX2, SMX2/A, SWX/A, SX/A, SXB/A, SXB7, SXB7/A, SXE/A, SXEB/A, SXE2, SXE4, SXE4/A, SXE8, SXE8/A, SXQ4, SXQ4/A, SXU, SXU/A, S1/A, VA2, VA2/A, HA, HAQ, HH, HX, LH, LHC, LHE, LKE, LX, LXE, LXZ, L1, PX, P1, QA, QAE, QAP, QAPE, QAQ, QE, QH, QHC, QHE, QNE, QNE9, QP, QT, QX, QXB, QXC, QXE, QXEB, Q1, SE, SH, SHE, SHEZ, SWX, SX, SXB, SXE, SXEB, SXP, S1, VA, V1	
			1	-	-	2540276 VH12	
			1	-	-	2206229 2540276 VAH1	
	93500-05045-0A	SCREW, PAN, 5X45	1	-	-	VH12/A	
			1	-	-	2540277 VH12	
33	94050-06000	NUT, FLANGE, 6MM	1	-	-	EDE2, EDE2/A, EDK, EDN, EDN2, EDN2/A, EDN5, EDN5/A, EDS, EDS3, EDS4, EDS5, EDS6, EDS6/A, EDT3, EDT6, EDT6/A, ED6, ED6/A, ED7, ED8, ED8/A, ED9, ED9/A, EMT, EMT/A, EN, ENT2, EN6, EN6/A, ES, ES1, ES1/A, ES2, ES3, ES3/A, ES4, ES4/A, ET, ETS, ETX, HA, HAQ, HA2, HA2/A, HH, HX, HX2, HX26, HX26/A, LH, LH/A, LHB1, LHB3, LHB3/A, LHB5, LHC, LHE, LHE/A, LHQ4, LHQ4/A, LHW, LJS, LJS/A, LJS1, LKE, LKE/A, LT, LT/A, LWD, LX, LX/A, LXE, LXE/A, LXE2, LXE2/A, LXE4, LXE4/A, LXE6, LXE8, LXE8/A, LXQ4, LXQ4/A, LXU, LXU/A, LXZ, LX2, LX2/A, LX26, LX26/A, PKT2, PKT2/A, PKT4, PKT4/A, PKX2, PKX4, PKX4/A, PX, PX/A, PXA2, PXE8, PXE8/A, QA, QAE, QAE2, QAE2/A, QAE6, QAE6/A, QAP, QAPE, QAP2, QAP2/A, QAQ, QA2, QA2/A, QA26, QA26/A, QDW9, QDW9/A, QE, QE/A, QH, QH/A, QHB3, QHB3/A, QHB5, QHC, QHE, QHE/A, QHP1, QHP1/A, QHQ4, QHQ4/A, QH2, QKA4, QKA4/A, QME0, QME0/A, QME8, QME8/A, QMH, QMH/A, QMT2, QMT2/A, QNE, QNE2, QNE2/A, QNE6, QNE9, QNE9/A, QNR2, QNR2/A, QNR6, QNR6/A, QN18, QP, QP/A, QPE2, QT, QT/A, QTC2, QTC2/A, QX, QX/A, QXB, QXB/A, QXB7, QXB7/A, QXC, QXC/A, QXC4, QXC4/A, QXC6, QXC6/A, QXC9, QXC9/A, QXE, QXE/A, QXEB, QXE2, QXE4, QXE4/A, QXE6, QXE6/A, QXE8, QXE8/A, QXQ4, QXQ4/A, QXU, QXU/A, QX2, SE, SE/A, SH, SH/A, SHB1, SHB3, SHB3/A, SHE, SHEZ, SHQ4, SHQ4/A, SHT, SMEO, SMEO/A, SME2, SMX2, SMX2/A, SWX, SWX/A, SX, SX/A, SXB, SXB/A, SXB7, SXB7/A, SXE, SXE/A, SXEB, SXEB/A, SXE2, SXE4, SXE4/A, SXE8, SXE8/A, SXP, SXQ4, SXQ4/A, SXU, SXU/A, VA, VAA, VAAE, VAD2, VAD2/A, VAH1, VAH2, VAW1, VA2, VA2/A, VC2, VC2/A, VDE, VDE2, VDE2/A, VD16, VE, VEB6, VH, VHE, VH12, VH12/A, VH22, VH22/A, VMQ, VMT, VMT/A, VMX, VNG, VNG1, VNG2, VSH7, VS2, VS3, VS4, VS5, VS6, VS7, VTE2, VWA, VWA2, VWC, VWC2, VWC2/A, VWE, VWE2, VWE2/A, VWS2, VWS2/A, VW12, VW12/A, VX, VX/A, VXA, VXB, VXB/A, VXB2, VXB7, VXB7/A, VXE, VXE/A, VXEB, VXEB/A, VXE2, VXE2/A, VXE4, VXE6, VXE7, VXE7/A, VXE8, VXE8/A, VXG, VXK, VXQ4, VXQ4/A, VXU, VXU/A, VXU1, VXU1/A, VX16, VX16/A, VX8, VX8/A	
			-	1	1		



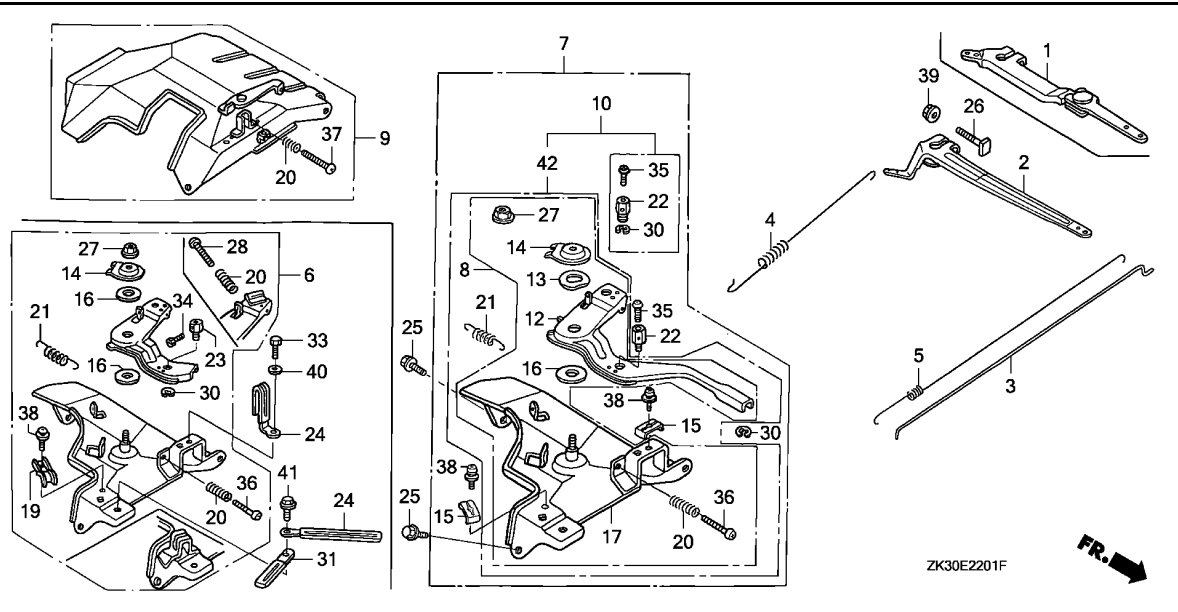

Ref. No.	L.O.N.	(Relative ref. Number) Description	F.R.T.
2		(1)	
2	1161A0	ARM, GOVERNOR .....	0.2
3	1161B1	ROD, GOVERNOR .....	0.3
4	1161C5	SPRING, GOVERNOR .....	0.2
5	1161C2	SPRING, THROTTLE RETURN .....	0.3
7		(6,9,10,42)	
	1161A5	CONTROL, THROTTLE/GOVERNOR ...	0.2
12	1161A8	LEVER, CONTROL .....	0.3
17	1161A2	BASE, CONTROL .....	0.3
21	1161B7	SPRING, CABLE RETURN .....	0.1



Ref. No.	Part No.	Description	Reqd. QTY			Serial No.	Parts catalogue code
			GX 340K1	(1)	(2)		
1	16550-ZE3-700	ARM COMP., GOVERNOR .....	1	-	-	EDS1,EDS1/A,EDS2,EDS2/A,EDT,EDT/A,EDT1/A,EDT2,ENT,ENT/A	
2	16551-ZE3-000	ARM, GOVERNOR .....	1	-	-	2297187	EDT1 BJ,LJ,LJ/A,LJG,LJG/A,LSX,QAB2,QAB2/A,QAC2,QAC2/A,QAG,QAG/A,QAH2 QAH2/A,QL2,QMX2,QWH2,QWH2/A,SDE,SJ,SJ/A,SJG,SJG/A,SKE,SKE/A,SKZ SKZ/A,STJ,STJ/A,STP,STP/A,STQ,STQ/A,STR,STR/A,YJ,ZK1,ZK1/A
			1	-	-	2297186	EDT1
3	16555-ZE3-000	ROD, GOVERNOR .....	1	1	-	2117541	BJ,LJ,L1,P1,Q1,SJ,STJ,STP,STQ,S1,V1,YJ
			1	-	-		EDS1,EDS1/A,EDS2,EDS2/A,EDT,EDT/A,EDT1,EDT1/A,EDT2,ENT,ENT/A LJG/A,QAB2,QAB2/A,QAC2,QAC2/A,QAG,QAG/A,QAH2,QAH2/A,QL2,QMX2,QWH2 QWH2/A,SJG/A,SKE/A,SKZ/A,STR/A,ZK1,ZK1/A
	16555-ZE3-W00	ROD, GOVERNOR (STD.) .....	1	1	-	3032024	LJG,SDE,SJG,SKE,SKZ,STR
			1	1	-		LJ/A,LSX,L1/A,P1/A,Q1/A,SJ/A,STJ/A,STP/A,STQ/A,S1/A
			1	1	-	2117542	BJ,LJ,L1,P1,Q1,SJ,STJ,STP,STQ,S1,V1,YJ
4	16561-ZE3-000	SPRING, GOVERNOR .....	1	-	-	3032023	LJG,SDE,SJG,SKE,SKZ,STR
			1	-	-		BJ,EDS1,EDS1/A,EDS2,EDS2/A,EDT,EDT/A,EDT1,EDT1/A,EDT2,ENT,ENT/A LJ,LJ/A,LJG,LJG/A,LSX,QAB2,QAB2/A,QAC2,QAC2/A,QAG,QAG/A,QAH2 QAH2/A,QL2,QMX2,QWH2,QWH2/A,SDE,SJ,SJ/A,SJG,SJG/A,SKE,SKE/A,SKZ SKZ/A,STJ,STJ/A,STP,STP/A,STQ,STQ/A,STR,STR/A,YJ,ZK1,ZK1/A
5	16562-ZE3-000	SPRING, THROTTLE RETURN .....	1	-	-		BJ,LJ,LJ/A,LJG,LJG/A,LSX,QAB2,QAB2/A,QAC2,QAC2/A,QAG,QAG/A,QAH2 QAH2/A,QL2,QMX2,QWH2,QWH2/A,SDE,SJ,SJ/A,SJG,SJG/A,SKE,SKE/A,SKZ SKZ/A,STJ,STJ/A,STP,STP/A,STQ,STQ/A,STR,STR/A,YJ,ZK1,ZK1/A
			1	-	-	2297186	EDT1
			-	1	-		
	16562-ZE3-700	.....	1	-	-		EDS1,EDS1/A,EDS2,EDS2/A,EDT,EDT/A,EDT1/A,ENT,ENT/A
			1	-	-	2297187	EDT1
6	16570-ZE3-L60	CONTROL ASSY. (REMOTE) .....	1	-	-	2375015	ZK1

Ref. No.	Part No.	Description	Reqd. QTY			Serial No.	Parts catalogue code	
			(1)	(2)	(3)			
(6)	16570-ZE3-L61	CONTROL ASSY. (REMOTE) .....	1	-	-	-----	ZK1/A	
			1	-	-	2375016	-----	ZK1
7	16570-ZE3-R90	CONTROL ASSY. (DELICA) .....	1	-	-	-----	-----	SDE
8	16570-ZE3-W00	CONTROL ASSY. (STD.) .....	-	(1)	-	-----	-----	
	16570-ZE3-W30	CONTROL ASSY. (REMOTE) .....	-	(1)	-	-----	-----	
9	16570-ZE3-700	CONTROL ASSY. ....	1	-	-	-----	-----	EDS1,EDS1/A,EDS2,EDS2/A,EDT,EDT/A,EDT1,EDT1/A,EDT2,ENT,ENT/A
10	16570-ZE3-W10	CONTROL ASSY. (REMOTE) .....	1	-	-	-----	-----	BJ,LJ,LJ/A,LJG,LJG/A,SJ,SJ/A,SJG,SJG/A,SKE,SKE/A,SKZ,SKZ/A,STJ
			-	(1)	-	-----	-----	STJ/A,STP,STP/A,STQ,STQ/A,STR,STR/A,YJ
12	16571-ZE3-W00	LEVER, CONTROL .....	1	-	-	-----	-----	BJ,LJ,LJ/A,LJG,LJG/A,LSX,QAB2,QAB2/A,QAC2,QAC2/A,QAG,QAG/A,QAQ2
			-	(1)	-	-----	-----	QAQ2/A,QL2,QMX2,QWH2,QWH2/A,SDE,SJ,SJ/A,SJG,SJG/A,SKE,SKE/A,SKZ
	16571-ZE3-W10	.....	-	(1)	-	-----	-----	SKZ/A,STJ,STJ/A,STP,STP/A,STQ,STQ/A,STR,STR/A,YJ
13	16574-ZE1-000	SPRING, LEVER .....	1	-	-	-----	-----	BJ,LJ,LJ/A,LJG,LJG/A,LSX,QAB2,QAB2/A,QAC2,QAC2/A,QAG,QAG/A,QAQ2
			-	(1)	-	-----	-----	QAQ2/A,QL2,QMX2,QWH2,QWH2/A,SDE,SJ,SJ/A,SJG,SJG/A,SKE,SKE/A,SKZ
			-	(1)	-	-----	-----	SKZ/A,STJ,STJ/A,STP,STP/A,STQ,STQ/A,STR,STR/A,YJ
14	16575-ZE2-W00	WASHER, CONTROL LEVER .....	1	-	-	-----	-----	BJ,LJ,LJ/A,LJG,LJG/A,LSX,QAB2,QAB2/A,QAC2,QAC2/A,QAG,QAG/A,QAQ2
			-	(1)	-	-----	-----	QAQ2/A,QL2,QMX2,QWH2,QWH2/A,SDE,SJ,SJ/A,SJG,SJG/A,SKE,SKE/A,SKZ
			-	(1)	-	-----	-----	SKZ/A,STJ,STJ/A,STP,STP/A,STQ,STQ/A,STR,STR/A,YJ,ZK1,ZK1/A
15	16576-891-000	HOLDER, CABLE .....	1	-	-	-----	-----	BJ,LJ,LJ/A,LJG,LJG/A,LSX,QAB2,QAB2/A,QAC2,QAC2/A,QAG,QAG/A,QAQ2
			-	(1)	-	-----	-----	QAQ2/A,QL2,QMX2,QWH2,QWH2/A,SDE,SJ,SJ/A,SJG,SJG/A,SKE,SKE/A,SKZ
			-	(1)	-	-----	-----	SKZ/A,STJ,STJ/A,STP,STP/A,STQ,STQ/A,STR,STR/A,YJ
16	16578-ZE1-000	SPACER, CONTROL LEVER .....	1	-	-	-----	-----	BJ,LJ,LJ/A,LJG,LJG/A,LSX,QAB2,QAB2/A,QAC2,QAC2/A,QAG,QAG/A,QAQ2
			2	-	-	-----	-----	QAQ2/A,QL2,QMX2,QWH2,QWH2/A,SDE,SJ,SJ/A,SJG,SJG/A,SKE,SKE/A,SKZ
			-	(1)	-	-----	-----	SKZ/A,STJ,STJ/A,STP,STP/A,STQ,STQ/A,STR,STR/A,YJ
			2	-	-	-----	-----	ZK1,ZK1/A
17	16581-ZE3-W00	BASE COMP., CONTROL (###) ...	1	-	-	-----	-----	BJ,LJ,LJ/A,LJG,LJG/A,LSX,QAB2,QAB2/A,QAC2,QAC2/A,QAG,QAG/A,QAQ2
			-	(1)	-	-----	-----	QAQ2/A,QL2,QMX2,QWH2,QWH2/A,SDE,SJ,SJ/A,SJG,SJG/A,SKE,SKE/A,SKZ
			-	(1)	-	-----	-----	SKZ/A,STJ,STJ/A,STP,STP/A,STQ,STQ/A,STR,STR/A,YJ
19	16582-883-300	HOLDER, CONTROL CABLE .....	1	-	-	-----	2375015	ZK1
20	16584-883-300	SPRING, CONTROL ADJUSTING ...	1	-	-	-----	-----	BJ,EDS1,EDS1/A,EDS2,EDS2/A,EDT,EDT/A,EDT1,EDT1/A,EDT2,ENT,ENT/A
			1	-	-	-----	2375015	-----
			-	(1)	-	-----	-----	LJ,LJ/A,LJG,LJG/A,LSX,QAB2,QAB2/A,QAC2,QAC2/A,QAG,QAG/A,QAQ2
			2	-	-	-----	-----	QAQ2/A,QL2,QMX2,QWH2,QWH2/A,SDE,SJ,SJ/A,SJG,SJG/A,SKE,SKE/A,SKZ
			2	-	-	-----	2375016	-----
			-	(1)	-	-----	-----	SKZ/A,STJ,STJ/A,STP,STP/A,STQ,STQ/A,STR,STR/A,YJ
21	16592-883-310	SPRING, CABLE RETURN .....	1	-	-	-----	-----	BJ,LJ,LJ/A,LJG,LJG/A,LSX,QAB2,QAB2/A,QAC2,QAC2/A,QAG,QAG/A,QAQ2
			-	(1)	-	-----	-----	QAQ2/A,QL2,QMX2,QWH2,QWH2/A,SDE,SJ,SJ/A,SJG,SJG/A,SKE,SKE/A,SKZ
			-	(1)	-	-----	-----	SKZ/A,STJ,STJ/A,STP,STP/A,STQ,STQ/A,STR,STR/A,YJ,ZK1,ZK1/A
22	16594-883-010	HOLDER, WIRE .....	1	-	-	-----	-----	BJ,LJ,LJ/A,LJG,LJG/A,QMX2,SJ,SJ/A,SJG,SJG/A,SKE,SKE/A,SKZ,SKZ/A
			2	-	-	-----	-----	STJ,STJ/A,STP,STP/A,STQ,STQ/A,STR,STR/A,YJ
			-	(1)	-	-----	-----	SDE
23	16617-ZE3-H00	HOLDER, WIRE .....	1	-	-	-----	-----	ZK1,ZK1/A
24	32170-KR5-000	CLIP, WIRE HARNESS .....	3	-	-	-----	2767218	ZK1



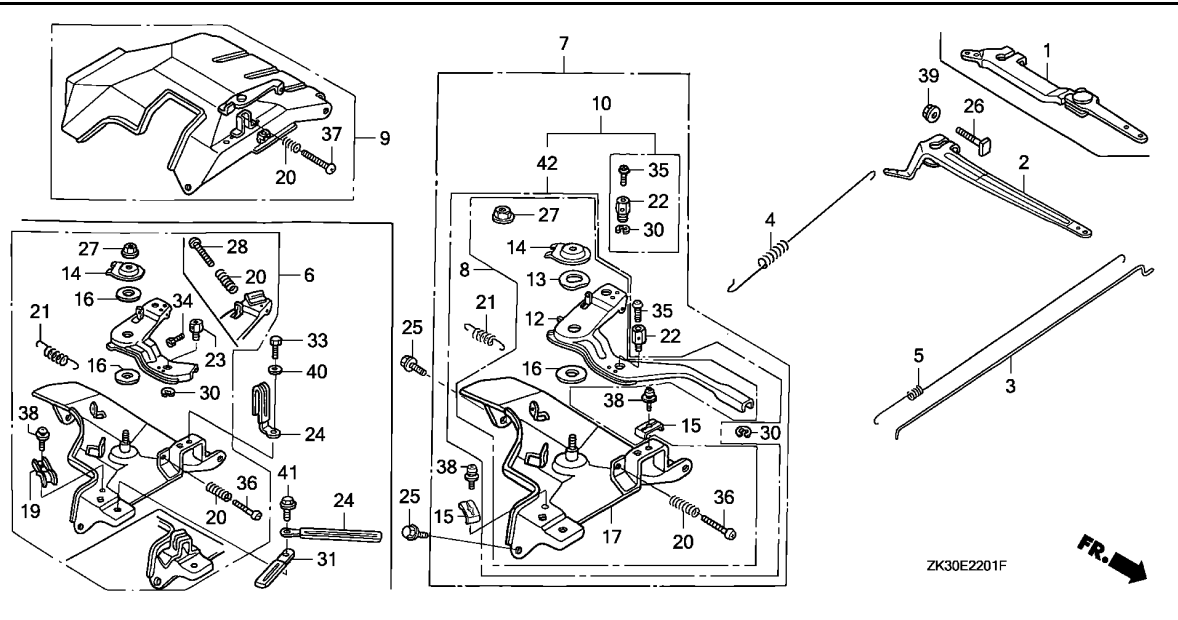

Ref. No.	Part No.	Description	Reqd. QTY			Serial No.	Parts catalogue code
			GX	(1)	(2)		
25	90013-883-000	BOLT, FLANGE, 6X12(CT200) ...	2	-	-	-----	BJ,EDS1,EDS1/A,EDS2,EDS2/A,EDT,EDT/A,EDT1,EDT1/A,EDT2,ENT,ENT/A LJ,LJ/A,LJG,LJG/A,LSX,QAB2,QAB2/A,QAC2,QAC2/A,QAG,QAG/A,QAH2 QAH2/A,QL2,QMX2,QWH2,QWH2/A,SDE,SJ,SJ/A,SJG,SJG/A,SKE,SKE/A,SKZ SKZ/A,STJ,STJ/A,STP,STP/A,STQ,STQ/A,STR,STR/A,YJ,ZK1,ZK1/A
			-	2	-		
26	90015-ZE5-010	BOLT, GOVERNOR ARM .....	1	-	-	-----	BJ,EDS1,EDS1/A,EDS2,EDS2/A,EDT,EDT/A,EDT1,EDT1/A,EDT2,ENT,ENT/A LJ,LJ/A,LJG,LJG/A,LSX,QAB2,QAB2/A,QAC2,QAC2/A,QAG,QAG/A,QAH2 QAH2/A,QL2,QMX2,QWH2,QWH2/A,SDE,SJ,SJ/A,SJG,SJG/A,SKE,SKE/A,SKZ SKZ/A,STJ,STJ/A,STP,STP/A,STQ,STQ/A,STR,STR/A,YJ,ZK1,ZK1/A
27	90114-SA0-000	NUT, SELF-LOCK, 6MM .....	1	-	-	-----	BJ,LJ,LJ/A,LJG,LJG/A,LSX,QAB2,QAB2/A,QAC2,QAC2/A,QAG,QAG/A,QAH2 QAH2/A,QL2,QMX2,QWH2,QWH2/A,SDE,SJ,SJ/A,SJG,SJG/A,SKE,SKE/A,SKZ SKZ/A,STJ,STJ/A,STP,STP/A,STQ,STQ/A,STR,STR/A,YJ,ZK1,ZK1/A
28	90122-735-000	SCREW, PAN, 5X35 .....	1	-	-	2375016	ZK1
	93500-05032-0A	SCREW, PAN, 5X32 .....	1	-	-	-----	ZK1/A
			1	-	-	2492685	ZK1
30	90605-230-000	CIRCLIP, 5MM .....	1	-	-	-----	BJ,LJ,LJ/A,LJG,LJG/A,QMX2,SJ,SJ/A,SJG,SJG/A,SKE,SKE/A,SKZ,SKZ/A STJ,STJ/A,STP,STP/A,STQ,STQ/A,STR,STR/A,YJ,ZK1,ZK1/A
			2	-	-	-----	SDE
			-	(1)	-		
31	91406-657-671	CLIP, WIRE HARNESS .....	1	-	-	-----	ZK1,ZK1/A
33	92101-05012-0A	BOLT, HEX., 5X12 .....	1	-	-	-----	ZK1,ZK1/A
34	92301-04006-0A	BOLT, RECESSED, 4X6 .....	1	-	-	-----	ZK1,ZK1/A

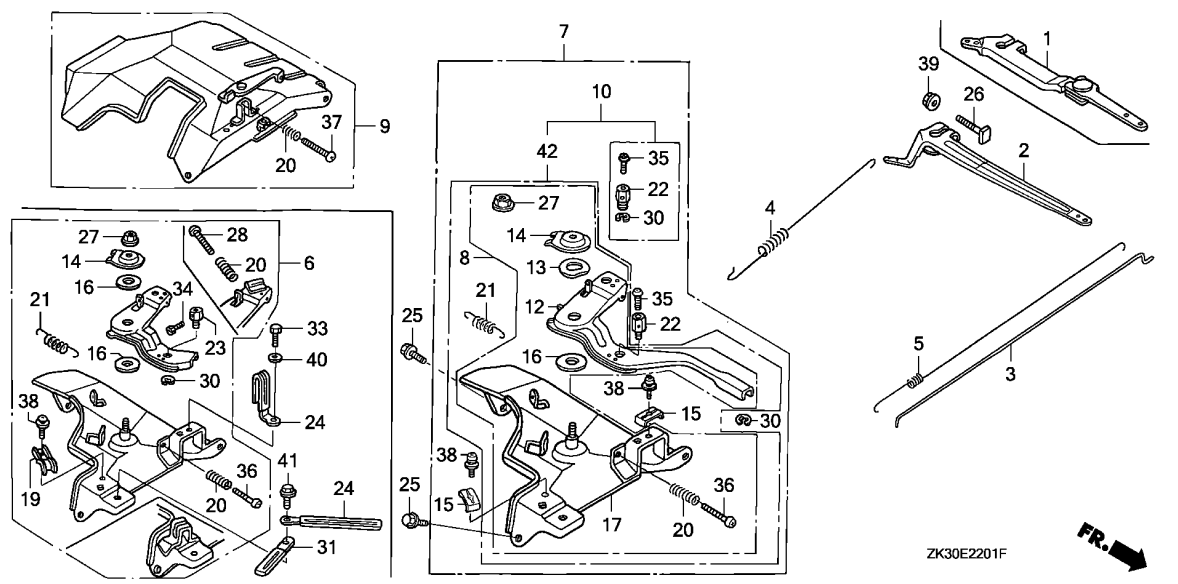

Ref. No.	Part No.	Description	Reqd. QTY			Serial No.	Parts catalogue code	
			GX	(1)	(2)			(3)
35	93500-04006-0H	SCREW, PAN, 4X6	1	-	-	-----	BJ,LJ,LJ/A,LJG,LJG/A,QMX2,SJ,SJ/A,SJG,SJG/A,SKE,SKE/A,SKZ,SKZ/A STJ,STJ/A,STP,STP/A,STQ,STQ/A,STR,STR/A,YJ	
			2	-	-	-----	SDE	
			-	(1)	-	-----		
36	93500-05032-0A	SCREW, PAN, 5X32	1	-	-	-----	BJ,LJ,LJ/A,LJG,LJG/A,LSX,QAB2,QAB2/A,QAC2,QAC2/A,QAG,QAG/A,QAH2 QAH2/A,QL2,QMX2,QWH2,QWH2/A,SDE,SJ,SJ/A,SJG,SJG/A,SKE,SKE/A,SKZ SKZ/A,STJ,STJ/A,STP,STP/A,STQ,STQ/A,STR,STR/A,YJ,ZK1/A	
			1	-	-	2375016	-----	ZK1
			-	(1)	-	-----		
37	93500-05035-0A	SCREW, PAN, 5X35	1	-	-	-----	EDS1,EDS1/A,EDS2,EDS2/A,EDT,EDT/A,EDT1,EDT1/A,EDT2,ENT,ENT/A	
38	93893-05016-00	SCREW-WASHER, 5X16	1	(1)	-	2206228	-----	BJ,LJ,L1,P1,Q1,SJ,STJ,STP,STQ,S1,V1,YJ
	93500-05016-0A	SCREW, PAN, 5X16	1	(1)	-	-----	LJ/A,LJG,LJG/A,LSX,L1/A,P1/A,QAB2,QAB2/A,QAC2,QAC2/A,QAG,QAG/A QAH2,QAH2/A,QL2,QMX2,QWH2,QWH2/A,Q1/A,SJ/A,SJG,SJG/A,SKE,SKE/A SKZ,SKZ/A,STJ/A,STP/A,STQ/A,STR,STR/A,S1/A	
			1	(1)	-	2206229	-----	BJ,LJ,L1,P1,Q1,SJ,STJ,STP,STQ,S1,V1,YJ
			1	-	-	2375015	-----	ZK1
			2	-	-	-----	SDE	
39	94050-06000	NUT, FLANGE, 6MM	1	-	-	-----	BJ,EDS1,EDS1/A,EDS2,EDS2/A,EDT,EDT/A,EDT1,EDT1/A,EDT2,ENT,ENT/A LJ,LJ/A,LJG,LJG/A,LSX,QAB2,QAB2/A,QAC2,QAC2/A,QAG,QAG/A,QAH2 QAH2/A,QL2,QMX2,QWH2,QWH2/A,SDE,SJ,SJ/A,SJG,SJG/A,SKE,SKE/A,SKZ SKZ/A,STJ,STJ/A,STP,STP/A,STQ,STQ/A,STR,STR/A,YJ,ZK1,ZK1/A	
			-	1	-	-----		
40	94101-05000	WASHER, PLAIN, 5MM	1	-	-	2767218	-----	ZK1
	94103-05000	.....	1	-	-	-----	ZK1/A	
			1	-	-	2767219	-----	ZK1
41	95701-06016-00	BOLT, FLANGE, 6X16	1	-	-	-----	ZK1,ZK1/A	
42	16570-ZE3-W20	CONTROL ASSY. (REMOTE)	1	-	-	-----	LSX,QAB2,QAB2/A,QAC2,QAC2/A,QAG,QAG/A,QAH2,QAH2/A,QL2,QWH2,QWH2/A	
			-	(1)	-	-----		



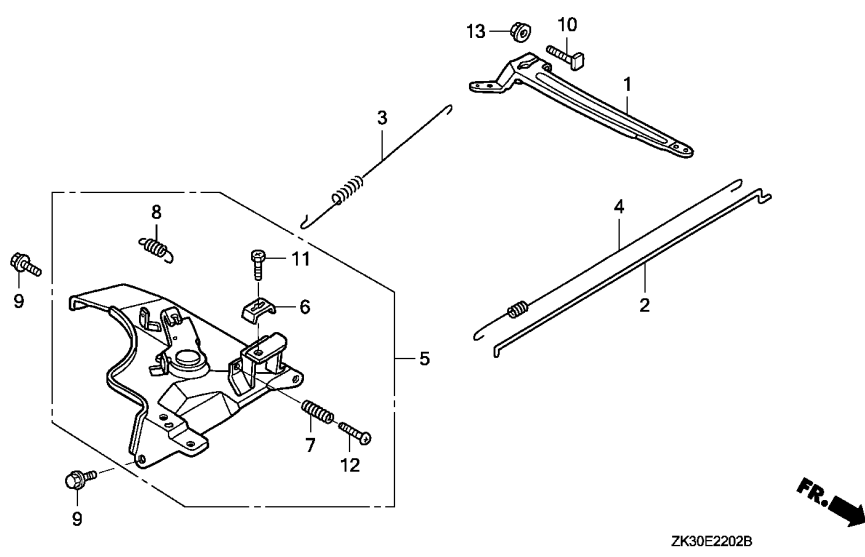

Ref. No.	L.O.N.	(Relative ref. Number) Description	F.R.T.
1	1161A0	ARM, GOVERNOR .....	0.2
2	1161B1	ROD, GOVERNOR .....	0.3
3	1161C5	SPRING, GOVERNOR .....	0.2
4	1161C2	SPRING, THROTTLE RETURN .....	0.3
5	1161A5	CONTROL, THROTTLE/GOVERNOR ...	0.2
8	1161B8	SPRING, CONTROL LEVER RETURN -	0.1

Ref. No.	Part No.	Description	Reqd. QTY			Serial No.	Parts catalogue code
			GX	340K1			
			(1)	(2)	(3)		
1	16551-ZE3-000	ARM, GOVERNOR .....	1	-	-	-----	LWD1,LWD1/A
2	16555-ZE3-000	ROD, GOVERNOR .....	1	-	-	-----	LWD1,LWD1/A
3	16561-ZE3-000	SPRING, GOVERNOR .....	1	-	-	-----	LWD1,LWD1/A
4	16562-ZE3-000	SPRING, THROTTLE RETURN .....	1	-	-	-----	LWD1,LWD1/A
5	16570-ZE3-H02	CONTROL ASSY. ....	1	-	-	-----	LWD1,LWD1/A
6	16576-891-000	HOLDER, CABLE .....	1	-	-	-----	LWD1,LWD1/A
7	16584-883-300	SPRING, CONTROL ADJUSTING ...	1	-	-	-----	LWD1,LWD1/A
8	16593-ZG1-700	SPRING, CONTROL LEVER RETURN	1	-	-	-----	LWD1,LWD1/A
9	90013-883-000	BOLT, FLANGE, 6X12(CT200) ...	2	-	-	-----	LWD1,LWD1/A
10	90015-ZE5-010	BOLT, GOVERNOR ARM .....	1	-	-	-----	LWD1,LWD1/A
11	92301-05016-0A	BOLT, RECESSED, 5X16 .....	1	-	-	-----	LWD1,LWD1/A
12	93500-05032-0A	SCREW, PAN, 5X32 .....	1	-	-	-----	LWD1,LWD1/A
13	94050-06000	NUT, FLANGE, 6MM .....	1	-	-	-----	LWD1,LWD1/A

2



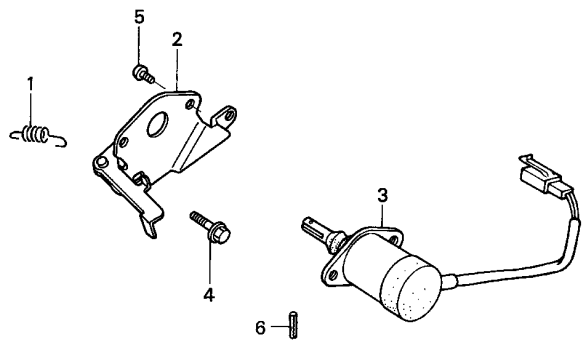

ZK30-E2220A **FR.** →

Ref. No.	L.O.N.	(Relative ref. Number) Description	F.R.T.
1	8101Q9	SPRING, CHOKE RETURN .....	0.1
2	8101H1	LEVER, THROTTLE .....	0.2
3	6211C5	SOLENOID, AUTO THROTTLE .....	0.2

Ref. No.	Part No.	Description	Reqd. QTY			Serial No.	Parts catalogue code
			GX	(1)	(2)		
1	16268-893-000	SPRING, CHOKE RETURN .....	1	-	-	-----	EDE2,EDE2/A,EDN,EDN2,EDN2/A,EDS,EDS2,EDS2/A,EDS5,EDS6,EDS6/A,EDT EDT/A,EDT6,EDT6/A,ED6,ED6/A,EMT,EMT/A,ENT,ENT/A,ENT2,EN6,EN6/A VC2,VC2/A,VMQ,VMT,VMT/A,VWC,VWE
2	17850-ZD1-E30	LEVER COMP., THROTTLE .....	1	-	-	2321344	EDS1 EDE2,EDE2/A,EDN,EDN2,EDN2/A,EDS,EDS2,EDS2/A,EDS5,EDS6,EDS6/A,EDT EDT/A,EDT6,EDT6/A,ED6,ED6/A,EMT,EMT/A,ENT,ENT/A,ENT2,EN6,EN6/A VC2,VC2/A,VMQ,VMT,VMT/A,VWC,VWE
3	36160-ZB4-003	SOLENOID ASSY. ....	1	-	-	2321344	EDS1 EDE2,EDE2/A,EDN,EDN2,EDN2/A,EDS,EDS2,EDS2/A,EDS5,EDS6,EDS6/A,EDT EDT/A,EDT6,EDT6/A,ED6,ED6/A,EMT,ENT,ENT/A,ENT2,EN6,EN6/A,VC2 VC2/A,VMT,VWC,VWE
	36160-ZB4-013	.....	1	-	-	2321344	EDS1
	4082960	.....	1	-	-	4082960	EMT/A,VMQ,VMT/A
4	90013-883-000	BOLT, FLANGE, 6X12(CT200) ...	1	-	-	4082961	EMT/A,VMQ,VMT/A
			1	-	-	-----	EDE2,EDE2/A,EDN,EDN2,EDN2/A,EDS,EDS2,EDS2/A,EDS5,EDS6,EDS6/A,EDT EDT/A,EDT6,EDT6/A,ED6,ED6/A,EMT,EMT/A,ENT,ENT/A,ENT2,EN6,EN6/A VC2,VC2/A,VMQ,VMT,VMT/A,VWC,VWE
5	93500-05008-0A	SCREW, PAN, 5X8 .....	1	-	-	2321344	EDS1
			2	-	-	-----	EDE2,EDE2/A,EDN,EDN2,EDN2/A,EDS,EDS2,EDS2/A,EDS5,EDS6,EDS6/A,EDT EDT/A,EDT6,EDT6/A,ED6,ED6/A,EMT,EMT/A,ENT,ENT/A,ENT2,EN6,EN6/A VC2,VC2/A,VMQ,VMT,VMT/A,VWC,VWE
			2	-	-	2321344	EDS1
6	94305-20062	PIN, SPRING, 2X6 .....	1	-	-	-----	EDE2,EDE2/A,EDN,EDN2,EDN2/A,EDS,EDS2,EDS2/A,EDS5,EDS6,EDS6/A,EDT EDT/A,EDT6,EDT6/A,ED6,ED6/A,EMT,EMT/A,ENT,ENT/A,ENT2,EN6,EN6/A VC2,VC2/A,VMQ,VMT,VMT/A,VWC,VWE
			1	-	-	2321344	EDS1



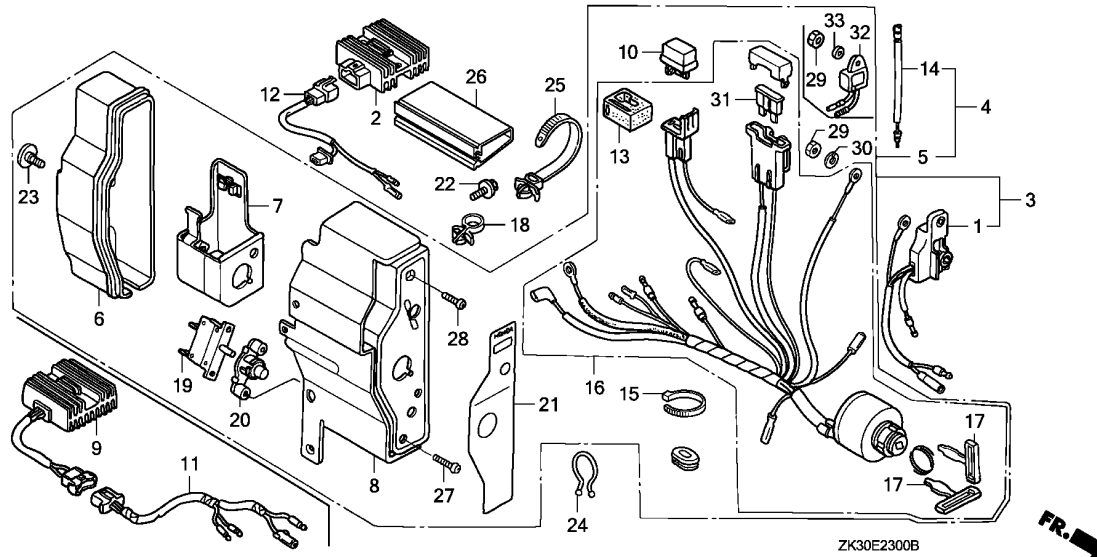

Ref. No.	L.O.N.	(Relative ref. Number) Description	F.R.T.
1		(32) ALERT UNIT, ENGINE CONTROL OIL	0.2
2		6131B7 RECTIFIER, REGULATOR	0.2
3		6221N7 BOX, ENGINE CONTROL	0.1
4		6221N7 BOX, ENGINE CONTROL	0.1
8		6151K5 PANEL, ENGINE CONTROL	0.2
9		6131B7 RECTIFIER, REGULATOR	0.2
10		6131B8 RECTIFIER, SILICON	0.1
11		6111E6 HARNESS, REGULATOR RECTIFIER	0.2
12		6111E6 HARNESS, REGULATOR RECTIFIER	0.2
16		6151E1 SWITCH, COMBINATION	0.2
19		6221D4 PROTECTOR, CIRCUIT	0.2
31		8121A7 FUSE, BLADE	0.1

Ref. No.	Part No.	Description	Reqd. QTY			Serial No.	Parts catalogue code
			GX	340K1			
			(1)	(2)	(3)		
1	15520-ZE2-822	ALERT UNIT, OIL (SEL) .....	1	(1)	-	2143683	ETS,LKE,LXE,QXE,QXEB,SXE,SXEB,S1,VAAE,VNG2,VXEB
2	31600-ZE2-861	RECTIFIER ASSY., REGULATOR (10A)	1	(1)	-	-----	LKE,LKE/A,QMEO,QMEO/A,QME8,QME8/A,QNE6,SME0,SME0/A,S1,S1/A
3	31610-ZE3-W11ZB	BOX ASSY., CONTROL (ALERT) *R8*.....BRIGHT RED	1	(1)	-	2143683	LXE,QXE,QXEB,SXE,SXEB,S1,VAAE,VXEB
	31610-ZE3-W11ZC	*T39*.....GEKO BLUE	1	-	-	2143683	VXEB
	31610-ZE3-W21ZB	BOX ASSY., CONTROL (ALERT) (3A) *R8*.....BRIGHT RED	-	(1)	-	2143683	S1
	31610-ZE3-W21ZC	*T39*.....GEKO BLUE	1	-	-	2143683	VNG2
	31610-ZE3-W31ZB	BOX ASSY., CONTROL (ALERT) (10A) *R8*.....BRIGHT RED	1	(1)	-	2143683	LKE,S1
4	31610-ZE3-W12ZB	BOX ASSY., CONTROL *R8*.....BRIGHT RED	1	(1)	-	-----	S1/A,VXE6
			1	(1)	-	2143684	----- QXEB,S1,VAAE
			1	-	-	2801237	LXE6,QXE6,VXU1
			1	-	-	2143684	2337496 SXEB,VXEB
			1	-	-	2143684	2801237 LXE,QXE,SXE
			1	-	-	2143684	2337496 VXEB
	31610-ZE3-W12ZC	*T39*.....GEKO BLUE	1	-	-	2143684	2337496 VXEB
	31610-ZE3-W22ZB	BOX ASSY., CONTROL (3A) *R8*.....BRIGHT RED	1	-	-	2801237	QAE6
			-	(1)	-	-----	S1/A
			-	(1)	-	2143684	----- S1
	31610-ZE3-W22ZC	*T39*.....GEKO BLUE	1	-	-	2143684	2337496 VNG2
	31610-ZE3-W32ZB	BOX ASSY., CONTROL (10A) *R8*.....BRIGHT RED	1	(1)	-	-----	QNE6,S1/A
			1	-	-	2143684	2398544 LKE
			-	(1)	-	2143684	----- S1



Ref. No.	Part No.	Description	Reqd. QTY			Serial No.	Parts catalogue code
			(1)	(2)	(3)		
(4)	31610-ZE3-W41ZB	BOX ASSY., CONTROL (18A)					
		*R8*.....BRIGHT RED	1	-	-	2801237	QNR6
	31610-ZE3-W13ZB	BOX ASSY., CONTROL (ALERT)					
		*R8*.....BRIGHT RED	1	-	-		LXE8,PXE8,QXE8,SXE8,VMT,VXE8
			1	-	-	2801238	LXE,LXE6,QXE,QXE6,SXE,VXU1
			1	-	-	3662261	LXE/A,LXE8/A,PXE8/A,QXE/A,QXE6/A,QXE8/A,SXE/A,SXE8/A,VMT/A,VXE8/A VXU1/A
	31610-ZE3-W23ZB	BOX ASSY., CONTROL (ALERT) (3A)					
		*R8*.....BRIGHT RED	1	-	-	2801238	QAE6
			1	-	-	3667984	QAE6/A
	31610-ZE3-W33ZB	BOX ASSY., CONTROL (EXP-ALERT) (10A)					
		*R8*.....BRIGHT RED	1	-	-		QME8
			1	-	-	3690533	QME8/A
	31610-ZE3-W42ZB	BOX ASSY., CONTROL (EXP-ALERT) (18A)					
		*R8*.....BRIGHT RED	1	-	-	2801238	QNR6
			1	-	-	3675839	QNR6/A
	31610-ZF6-W41ZA	BOX ASSY., CONTROL (ALERT)					
		*R8*.....BRIGHT RED	1	-	-		VEB6
			1	-	-	2801237	LXE4,QXE4,SXE4,VXE4
			1	-	-	2337497	SXEB,VXEB
			1	-	-	2398545	2566230 LKE
	31610-ZF6-W41ZB	*T39*.....GEKO BLUE	1	-	-	2801237	VXE4
			1	-	-	2337497	2801237 VXEB
	31610-ZF6-W51ZB	BOX ASSY., CONTROL (ALERT) (3A)					
		*T39*.....GEKO BLUE	1	-	-	2337497	VNG2
	31610-ZE3-W13ZE	BOX ASSY., CONTROL					
		*R280*.....POWER RED	1	-	-		VMQ
			1	-	-	3662262	LXE/A,LXE8/A,PXE8/A,QXE/A,QXE6/A,QXE8/A,SXE/A,SXE8/A,VMT/A,VXE8/A VXU1/A
	31610-ZE3-W23ZD	BOX ASSY., CONTROL (EXP-ALERT) (3A)					
		*R280*.....POWER RED	1	-	-	3667985	QAE6/A
	31610-ZE3-W33ZD	BOX ASSY., CONTROL (EXP-ALERT) (10A)					
		*R280*.....POWER RED	1	-	-	3690534	QME8/A
	31610-ZE3-W42ZD	BOX ASSY., CONTROL (EXP-ALERT) (18A)					
		*R280*.....POWER RED	1	-	-	3675840	QNR6/A
	31610-ZF6-W42ZA	BOX ASSY., CONTROL (ALERT)					
		*R8*.....BRIGHT RED	1	-	-		VXE7
			1	-	-	2801238	LXE4,QXE4,SXEB,SXE4,VXEB,VXE4
			1	-	-	3664509	LXE4/A,QXE4/A,SXEB/A,SXE4/A,VXEB/A,VXE7/A
	31610-ZF6-W42ZB	*T39*.....GEKO BLUE	1	-	-		VXEB/A
			1	-	-	2801238	VXEB,VXE4
			1	-	-		VXE7,VXE7/A
	31610-ZF6-W42ZC	*NH105*...MAT BLACK (#15-#20)	1	-	-		
	31610-ZK6-W41ZA	BOX ASSY., CONTROL (10A)					
		*NH1*.....BLACK	1	-	-	2801237	QME0,SMEO
	31610-ZK6-W41ZB	*R8*.....BRIGHT RED	1	-	-	2801237	QME0,SMEO
			1	-	-	2566231	2801237 LKE
	31610-ZF6-W42ZE	BOX ASSY., CONTROL (EXP-ALERT)					
		*R280*.....POWER RED	1	-	-	3664510	LXE4/A,QXE4/A,SXEB/A,SXE4/A,VXEB/A,VXE7/A
	31610-ZK6-W42ZA	BOX ASSY., CONTROL (ALERT) (10A)					
		*NH1*.....BLACK	1	-	-		QME0/A,SMEO/A
			1	-	-	2801238	QME0,SMEO



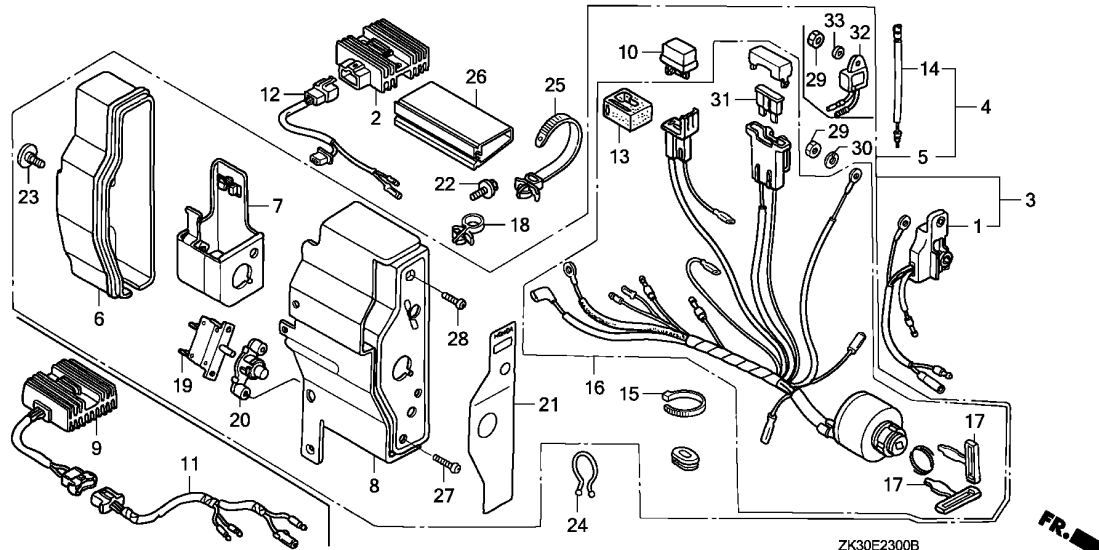

Ref. No.	Part No.	Description	Reqd. QTY			Serial No.	Parts catalogue code
			GX	(1)	(2)		
(4)	31610-ZK6-W42ZB	BOX ASSY., CONTROL (ALERT) (10A) *R8*.....BRIGHT RED	1	-	-	2801238	----- LKE,QMEO,SMEO 3682105 LKE/A,QMEO/A,SMEO/A
	31610-ZK6-W42ZC	BOX ASSY., CONTROL (EXP-ALERT) (10A) *R280*.....POWER RED	1	-	-	3682106	----- LKE/A,QMEO/A,SMEO/A
5	31610-ZE3-812ZB	BOX ASSY., CONTROL *R8*.....BRIGHT RED	1	(1)	-	-----	----- LHE,QHE,SHEZ,S1,VHE 3662149 ED7,LHE/A,QHE/A,SHE,S1/A
	31610-ZE3-842ZB	BOX ASSY., CONTROL (ALERT) (3A) *R8*.....BRIGHT RED	-	(1)	-	-----	----- S1,S1/A
	31610-ZE3-862ZB	BOX ASSY., CONTROL (10A) *R8*.....BRIGHT RED	-	(1)	-	-----	----- S1,S1/A
	31610-ZE3-812ZD	BOX ASSY., CONTROL *R280*.....POWER RED	1	1	-	3662150	----- ED7,LHE/A,QHE/A,SHE,S1/A
6	31612-ZE2-003	CASE, CONTROL .....	1	(1)	-	-----	----- ED7,LHE,LHE/A,LKE,LKE/A,LXE,LXE/A,LXE4,LXE4/A,LXE6,LXE8,LXE8/A PXE8,PXE8/A,QAE6,QAE6/A,QHE,QHE/A,QMEO,QMEO/A,QME8,QME8/A,QNE6 QNR6,QNR6/A,QXE,QXE/A,QXEB,QXE4,QXE4/A,QXE6,QXE6/A,QXE8,QXE8/A SHE,SHEZ,SMEO,SMEO/A,SXE,SXE/A,SXEB,SXEB/A,SXE4,SXE4/A,SXE8 SXE8/A,S1,S1/A,VAAE,VEB6,VHE,VMQ,VMT,VMT/A,VNG2,VXEB,VXEB/A,VXE4 VXE6,VXE7,VXE7/A,VXE8,VXE8/A,VXU1,VXU1/A
7	31614-ZE2-003	BRACKET, CASE MOUNTING .....	1	(1)	-	-----	----- ED7,ETS,LHE,LHE/A,LKE,LKE/A,LXE,LXE/A,LXE4,LXE4/A,LXE6,LXE8 LXE8/A,PXE8,PXE8/A,QAE6,QAE6/A,QHE,QHE/A,QMEO,QMEO/A,QME8,QME8/A QNE6,QNR6,QNR6/A,QXE,QXE/A,QXEB,QXE4,QXE4/A,QXE6,QXE6/A,QXE8 QXE8/A,SHE,SHEZ,SMEO,SMEO/A,SXE,SXE/A,SXEB,SXEB/A,SXE4,SXE4/A SXE8,SXE8/A,S1,S1/A,VAAE,VEB6,VHE,VMQ,VMT,VMT/A,VNG2,VXEB,VXEB/A VXE4,VXE6,VXE7,VXE7/A,VXE8,VXE8/A,VXU1,VXU1/A

Ref. No.	Part No.	Description	Reqd. QTY			Serial No.	Parts catalogue code
			(1)	(2)	(3)		
8	31615-ZE3-003ZA	PANEL COMP., CONTROL					
		*NH1*.....BLACK	1	-	-	-----	QME0,QME0/A,SME0,SME0/A
	31615-ZE3-003ZB	*R8*.....BRIGHT RED	1	(1)	-	-----	ED7,LHE,LKE,LXE,LXE4,LXE6,LXE8,PXE8,QAE6,QHE,QME0,QME8,QNE6,QNR6 QXE,QXEB,QXE4,QXE6,QXE8,SHE,SHEZ,SME0,SXE,SXEB,SXE4,SXE8,S1,VAAE VEB6,VHE,VMT,VXEB,VXE4,VXE6,VXE7,VXE8,VXU1
			1	(1)	-	3662149	LHE/A,LKE/A,LXE/A,LXE4/A,LXE8/A,PXE8/A,QAE6/A,QME0/A,QME8/A QNR6/A,QXE/A,QXE4/A,QXE6/A,QXE8/A,SME0/A,SXE/A,SXEB/A,SXE4/A SXE8/A,S1/A,VMT/A,VXEB/A,VXE7/A,VXE8/A,VXU1/A
	31615-ZE3-003ZC	*T39*.....GEKO BLUE	1	-	-	-----	VNG2,VXEB,VXEB/A,VXE4
	31615-ZE3-003ZD	*NH105*...MAT BLACK (#15-#20)	1	-	-	-----	VXE7,VXE7/A
	31615-ZE3-003ZE	*R280*.....POWER RED	1	(1)	-	3662150	LHE/A,LKE/A,LXE/A,LXE4/A,LXE8/A,PXE8/A,QAE6/A,QME0/A,QME8/A QNR6/A,QXE/A,QXE4/A,QXE6/A,QXE8/A,SME0/A,SXE/A,SXEB/A,SXE4/A SXE8/A,S1/A,VMT/A,VXEB/A,VXE7/A,VXE8/A,VXU1/A
			1	-	-	-----	QHE/A,VMQ
9	31620-ZG5-003	RECTIFIER ASSY., REGULATOR (20A)	1	-	-	-----	QAH2,QNR6
	31620-ZG5-013	.....	1	-	-	-----	QAH2/A,QNR6/A
10	31700-124-008	RECTIFIER ASSY., SILICON (SHINDENGEN)	1	(1)	-	-----	ED7,ETS,LHE,LHE/A,LXE,LXE/A,LXE4,LXE4/A,LXE6,LXE8,LXE8/A,PXE8 PXE8/A,QAE6,QAE6/A,QHE,QHE/A,QXE,QXE/A,QXEB,QXE4,QXE4/A,QXE6 QXE6/A,QXE8,QXE8/A,SHE,SHEZ,SXE,SXE/A,SXEB,SXEB/A,SXE4,SXE4/A SXE8,SXE8/A,S1,S1/A,VAAE,VEB6,VHE,VMQ,VMT,VMT/A,VNG2,VXEB,VXEB/A VXE4,VXE6,VXE7,VXE7/A,VXE8,VXE8/A,VXU1,VXU1/A
			1	-	-	2398545 2566230	LKE
11	32110-ZE2-W00	HARNESS ASSY., SUB WIRE .....	1	-	-	-----	QAH2,QAH2/A,QNR6,QNR6/A
12	32110-ZE2-860	HARNESS ASSY., SUB WIRE .....	1	(1)	-	-----	LKE,LKE/A,QME0,QME0/A,QME8,QME8/A,QNE6,SME0,SME0/A,S1,S1/A
13	32127-738-700	SUSPENSION, COUPLER .....	1	(1)	-	-----	ED7,ETS,LHE,LHE/A,LXE,LXE/A,LXE4,LXE4/A,LXE6,LXE8,LXE8/A,PXE8 PXE8/A,QAE6,QAE6/A,QHE,QHE/A,QXE,QXE/A,QXEB,QXE4,QXE4/A,QXE6 QXE6/A,QXE8,QXE8/A,SHE,SHEZ,SXE,SXE/A,SXEB,SXEB/A,SXE4,SXE4/A SXE8,SXE8/A,S1,S1/A,VAAE,VEB6,VHE,VMQ,VMT,VMT/A,VNG2,VXEB,VXEB/A VXE4,VXE6,VXE7,VXE7/A,VXE8,VXE8/A,VXU1,VXU1/A
			1	-	-	2398545 2566230	LKE
14	32197-ZE1-003	SUB HARNESS .....	1	(1)	-	-----	LKE/A,LXE/A,LXE4,LXE4/A,LXE6,LXE8,LXE8/A,PXE8,PXE8/A,QAE6,QAE6/A QME0,QME0/A,QME8,QME8/A,QNE6,QNR6,QNR6/A,QXE/A,QXE4,QXE4/A,QXE6 QXE6/A,QXE8,QXE8/A,SME0,SME0/A,SXE/A,SXEB/A,SXE4,SXE4/A,SXE8 SXE8/A,S1/A,VEB6,VMQ,VMT,VMT/A,VXEB/A,VXE4,VXE6,VXE7,VXE7/A,VXE8 VXE8/A,VXU1,VXU1/A
			1	(1)	-	2143684	LKE,LXE,QXE,QXEB,SXE,SXEB,S1,VAAE,VNG2,VXEB
15	32902-892-003	BAND .....	1	(1)	-	-----	ED7,LHE,LHE/A,LKE,LKE/A,LXE,LXE/A,LXE4,LXE4/A,LXE6,LXE8,LXE8/A PXE8,PXE8/A,QAE6,QAE6/A,QHE,QHE/A,QME0,QME0/A,QME8,QME8/A,QNE6 QNR6,QNR6/A,QXE,QXE/A,QXEB,QXE4,QXE4/A,QXE6,QXE6/A,QXE8,QXE8/A SHE,SHEZ,SME0,SME0/A,SXE,SXE/A,SXEB,SXEB/A,SXE4,SXE4/A,SXE8 SXE8/A,S1,S1/A,VAAE,VEB6,VHE,VMQ,VMT,VMT/A,VNG2,VXEB,VXEB/A,VXE4 VXE6,VXE7,VXE7/A,VXE8,VXE8/A,VXU1,VXU1/A
16	35100-ZE2-W01	SWITCH ASSY., COMBINATION (18A-CHARGE)	1	-	-	-----	QNR6,QNR6/A
	35100-ZE2-023	SWITCH ASSY., COMBINATION ...	1	(1)	-	-----	ED7,ETS,LHE,LHE/A,LXE,LXE4,LXE4/A,LXE6,LXE8,LXE8/A,PXE8,PXE8/A QHE,QHE/A,QXE,QXEB,QXE4,QXE4/A,QXE6,QXE6/A,QXE8,QXE8/A,SHE,SHEZ SXE,SXEB,SXEB/A,SXE4,SXE4/A,SXE8,SXE8/A,S1,VAAE,VEB6,VHE,VMT,VXEB VXEB/A,VXE4,VXE6,VXE7,VXE7/A,VXE8,VXE8/A,VXU1,VXU1/A
			1	(1)	-	4077286	LXE/A,QXE/A,SXE/A,S1/A,VMQ,VMT/A
			1	-	-	2398545 2566230	LKE
	35100-ZE2-842	SWITCH ASSY., COMBINATION (3A-CHARGE)	1	(1)	-	-----	QAE6,QAE6/A,S1,VNG2



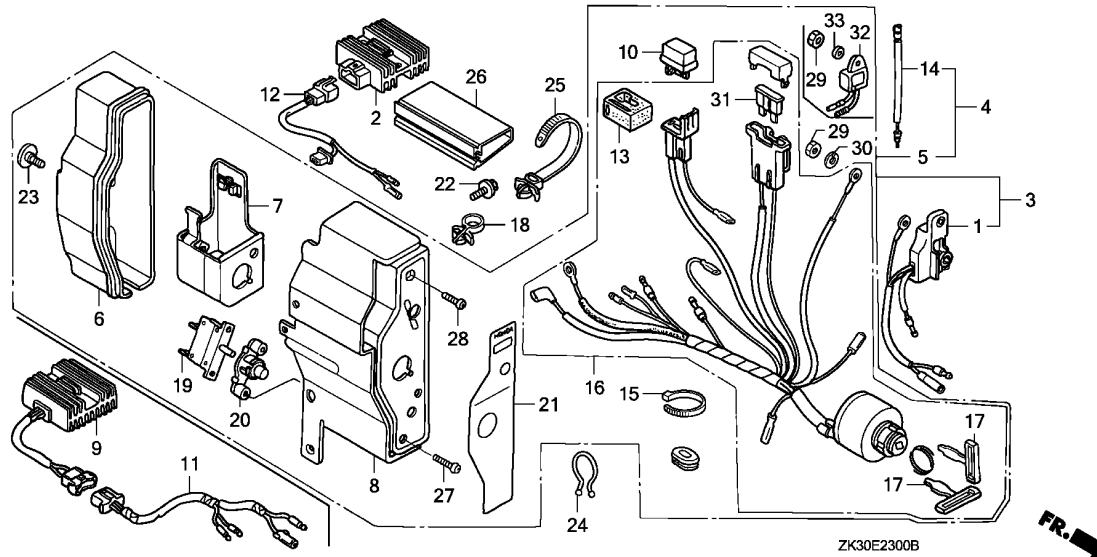

ZK30E2300B

FR. →

Ref. No.	Part No.	Description	Reqd. QTY			Serial No.	Parts catalogue code
			GX	340K1	(3)		
16)	35100-ZE2-862	SWITCH ASSY., COMBINATION (10A-CHARGE)	1	(1)	-	-----	QME0,QME0/A,QME8,QME8/A,QNE6,SMEO,SMEO/A,S1,S1/A
	35100-ZE2-033	SWITCH ASSY., COMBINATION ...	1	(1)	-	2398544	LKE
	35100-ZE2-843	SWITCH ASSY., COMBINATION (3A-CHARGE)	-	(1)	-	4077287	LXE/A,QXE/A,SXE/A,S1/A,VMQ,VMT/A
	35100-ZE2-862	SWITCH ASSY., COMBINATION (10A-CHARGE)	1	-	-	-----	S1/A
			1	-	-	-----	LKE/A
17	35111-880-003	KEY COMP. ....	1	-	-	2566231	LKE
			2	(2)	-	-----	ETS,LHE,LKE,LXE,LXE4,LXE8,PXE8,QAE6,QHE,QME0,QME8,QNE6,QNR6,QXE QXEB,QXE4,QXE6,QXE8,SHEZ,SMEO,SXE,SXEB,SXE4,SXE8,S1,VAAE,VEB6,VHE VMT,VNG2,VXEB,VXE6,VXE7,VXE8,VXU1
			2	(2)	-	3792398	LHE/A,LKE/A,LXE/A,LXE4/A,LXE8/A,PXE8/A,QAE6/A,QHE/A,QME0/A,QME8/A QNR6/A,QXE/A,QXE4/A,QXE6/A,QXE8/A,SMEO/A,SXE/A,SXEB/A,SXE4/A SXEB/A,S1/A,VMT/A,VXEB/A,VXE7/A,VXE8/A,VXU1/A
			2	-	-	3838382	ED7,LXE6,SHE,VXE4
	35111-880-013	.....	2	(2)	-	3792399	LHE/A,LKE/A,LXE/A,LXE4/A,LXE8/A,PXE8/A,QAE6/A,QHE/A,QME0/A,QME8/A QNR6/A,QXE/A,QXE4/A,QXE6/A,QXE8/A,SMEO/A,SXE/A,SXEB/A,SXE4/A SXEB/A,S1/A,VMT/A,VXEB/A,VXE7/A,VXE8/A,VXU1/A
			2	-	-	-----	VMQ
			2	-	-	3838383	ED7,LXE6,SHE,VXE4
18	36103-ZE1-000	HOLDER, STOP SWITCH CORD ....	1	(1)	-	-----	ED7,LHE,LHE/A,LKE,LKE/A,LXE,LXE/A,LXE4,LXE4/A,LXE6,LXE8,LXE8/A PXE8,PXE8/A,QAE6,QAE6/A,QHE,QHE/A,QME0,QME0/A,QME8,QME8/A,QNE6 QNR6,QNR6/A,QXE,QXE/A,QXEB,QXE4,QXE4/A,QXE6,QXE6/A,QXE8,QXE8/A SHE,SHEZ,SMEO,SMEO/A,SXE,SXE/A,SXEB,SXEB/A,SXE4,SXE4/A,SXE8 SXEB/A,S1,S1/A,VAAE,VEB6,VHE,VMQ,VMT,VMT/A,VNG2,VXEB,VXEB/A,VXE4 VXE6,VXE7,VXE7/A,VXE8,VXE8/A,VXU1,VXU1/A

2

Ref. No.	Part No.	Description	Reqd. QTY			Serial No.	Parts catalogue code	
			(1)	(2)	(3)			
19	38240-VA3-900	PROTECTOR, CIRCUIT (1.0A) ...	1	(1)	-	-----	ED7,ETS,LHE,LHE/A,LXE,LXE/A,LXE4,LXE4/A,LXE6,LXE8,LXE8/A,PXE8 PXE8/A,QHE,QHE/A,QXE,QXE/A,QXEB,QXE4,QXE4/A,QXE6,QXE6/A,QXE8 QXE8/A,SHE,SHEZ,SXE,SXE/A,SXEB,SXEB/A,SXE4,SXE4/A,SXE8,SXE8/A,S1 S1/A,VAAE,VEB6,VHE,VMQ,VMT,VMT/A,VXEB,VXEB/A,VXE4,VXE6,VXE7 VXE7/A,VXE8,VXE8/A,VXU1,VXU1/A	
	38240-ZE2-840	PROTECTOR, CIRCUIT (3.5A) ...	1	-	-	2398545	2566230	LKE QAE6,QAE6/A,S1,S1/A,VNG2
20	38250-ZA8-701	LENS ASSY., PROTECTOR .....	1	(1)	-	-----	-----	ED7,ETS,LHE,LHE/A,LXE,LXE/A,LXE4,LXE4/A,LXE6,LXE8,LXE8/A,PXE8 PXE8/A,QAE6,QAE6/A,QHE,QHE/A,QXE,QXE/A,QXEB,QXE4,QXE4/A,QXE6 QXE6/A,QXE8,QXE8/A,SHE,SHEZ,SXE,SXE/A,SXEB,SXEB/A,SXE4,SXE4/A SXE8,SXE8/A,S1,S1/A,VAAE,VEB6,VHE,VMQ,VMT,VMT/A,VNG2,VXEB,VXEB/A VXE4,VXE6,VXE7,VXE7/A,VXE8,VXE8/A,VXU1,VXU1/A
			1	-	-	2398545	2566230	LKE
21	87529-ZE2-831	PANEL, CONTROL BOX (EXTERNAL-ALERT)	1	(1)	-	-----	2143683	LXE,QXE,QXEB,SXE,SXEB,S1,VAAE,VNG2,VXEB
	87529-ZE2-870	MARK, CONTROL BOX (EXTERNAL-ALERT)(REGULATOR)	1	(1)	-	-----	2143683	LKE,S1
	87529-ZE2-811	MARK, CONTROL BOX (EXTERNAL)	1	(1)	-	-----	-----	ED7,LHE,LXE6,LXE8,PXE8,QAE6,QHE,QXE6,QXE8,SHE,SHEZ,SXE8,S1,VHE VMT,VXE6,VXE8,VXU1
			1	(1)	-	-----	3723964	LHE/A,LXE/A,LXE8/A,PXE8/A,QAE6/A,QHE/A,QXE/A,QXE6/A,QXE8/A,SXE/A SXE8/A,S1/A,VMT/A,VXE8/A,VXU1/A
			1	-	-	2143684	-----	LXE,QXE,QXEB,SXE,VAAE
			1	-	-	2143684	2337496	SXEB,VNG2,VXEB
	87529-ZE2-860	MARK, CONTROL BOX (EXTERNAL-REGULATOR)	1	(1)	-	-----	-----	QME8,QNE6,QNR6,S1
			1	(1)	-	-----	3724889	QME8/A,QNR6/A,S1/A
			1	-	-	2143684	2398544	LKE
	87529-ZE2-812	MARK, CONTROL BOX (EXP) .....	1	(1)	-	3723965	-----	LHE/A,LXE/A,LXE8/A,PXE8/A,QAE6/A,QHE/A,QXE/A,QXE6/A,QXE8/A,SXE/A SXE8/A,S1/A,VMT/A,VXE8/A,VXU1/A
			1	-	-	-----	-----	VMQ
	87529-ZE2-861	MARK, CONTROL BOX (EXTERNAL-REGULATOR)	1	(1)	-	3724890	-----	QME8/A,QNR6/A,S1/A
	87529-ZH9-W40	MARK, CONTROL BOX (ENGLISH) .	1	-	-	-----	-----	LXE4,QXE4,SXE4,VEB6,VXE4,VXE7
			1	-	-	2337497	-----	SXEB,VNG2,VXEB
			1	-	-	-----	3746667	LXE4/A,QXE4/A,SXEB/A,SXE4/A,VXEB/A,VXE7/A
			1	-	-	2398545	2566230	LKE
	87529-ZH8-W40	.....	1	-	-	-----	-----	QME0,SMEO
			1	-	-	2566231	-----	LKE
			1	-	-	-----	3746683	LKE/A,QME0/A,SMEO/A
	87529-ZH9-W41	.....	1	-	-	3746668	-----	LXE4/A,QXE4/A,SXEB/A,SXE4/A,VXEB/A,VXE7/A
	87529-ZH8-W41	.....	1	-	-	3746684	-----	LKE/A,QME0/A,SMEO/A
22	90013-883-000	BOLT, FLANGE, 6X12(CT200) ...	2	(2)	-	-----	-----	ED7,LHE,LHE/A,LKE,LKE/A,LXE,LXE/A,LXE4,LXE4/A,LXE6,LXE8,LXE8/A PXE8,PXE8/A,QAE6,QAE6/A,QHE,QHE/A,QME0,QME0/A,QME8,QME8/A,QNE6 QNR6,QNR6/A,QXE,QXE/A,QXEB,QXE4,QXE4/A,QXE6,QXE6/A,QXE8,QXE8/A SHE,SHEZ,SMEO,SMEO/A,SXE,SXE/A,SXEB,SXEB/A,SXE4,SXE4/A,SXE8 SXE8/A,S1,S1/A,VAAE,VEB6,VHE,VMQ,VMT,VMT/A,VNG2,VXEB,VXEB/A,VXE4 VXE6,VXE7,VXE7/A,VXE8,VXE8/A,VXU1,VXU1/A
23	90380-MA6-010	SCREW, SPECIAL, 6X12 .....	1	(1)	-	-----	-----	ED7,LHE,LHE/A,LKE,LKE/A,LXE,LXE/A,LXE4,LXE4/A,LXE6,LXE8,LXE8/A PXE8,PXE8/A,QAE6,QAE6/A,QHE,QHE/A,QME0,QME0/A,QME8,QME8/A,QNE6 QNR6,QNR6/A,QXE,QXE/A,QXEB,QXE4,QXE4/A,QXE6,QXE6/A,QXE8,QXE8/A SHE,SHEZ,SMEO,SMEO/A,SXE,SXE/A,SXEB,SXEB/A,SXE4,SXE4/A,SXE8 SXE8/A,S1,S1/A,VAAE,VEB6,VHE,VMQ,VMT,VMT/A,VNG2,VXEB,VXEB/A,VXE4 VXE6,VXE7,VXE7/A,VXE8,VXE8/A,VXU1,VXU1/A



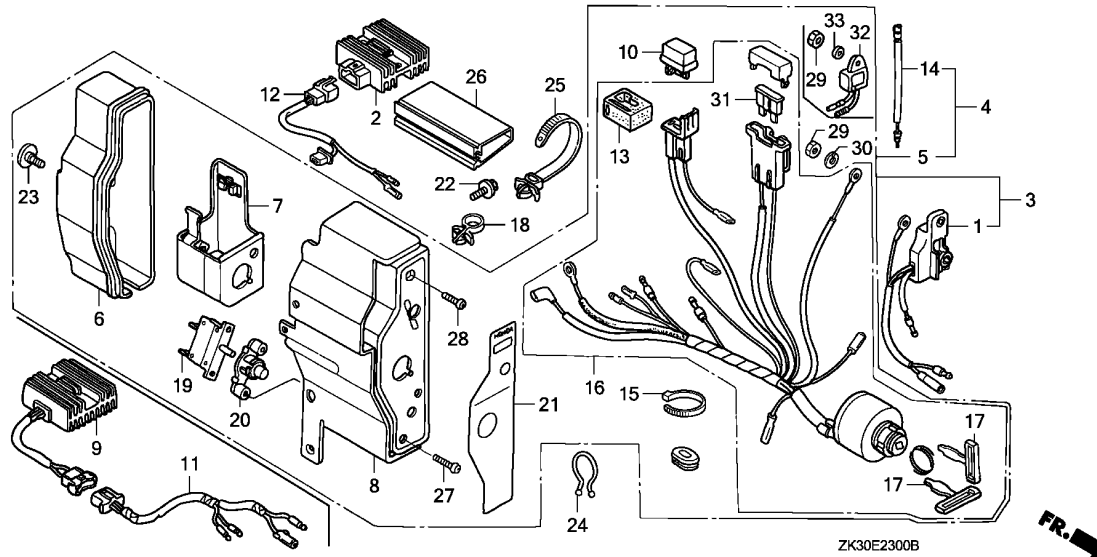

Ref. No.	Part No.	Description	Reqd. QTY			Serial No.	Parts catalogue code
			GX	340K1			
			(1)	(2)	(3)		
24	90630-751-000	CLIP, PURSE LOCK .....	1	(1)	-	-----	ED7,LHE,LHE/A,LKE,LKE/A,LXE,LXE/A,LXE4,LXE4/A,LXE6,LXE8,LXE8/A PXE8,PXE8/A,QAE6,QAE6/A,QHE,QHE/A,QME0,QME0/A,QME8,QME8/A,QNE6 QNR6,QNR6/A,QXE,QXE/A,QXEB,QXE4,QXE4/A,QXE6,QXE6/A,QXE8,QXE8/A SHE,SHEZ,SMEO,SMEO/A,SXE,SXE/A,SXEB,SXEB/A,SXE4,SXE4/A,SXE8 SXE8/A,S1,S1/A,VAAE,VEB6,VHE,VMQ,VMT,VMT/A,VNG2,VXEB,VXEB/A,VXE4 VXE6,VXE7,VXE7/A,VXE8,VXE8/A,VXU1,VXU1/A
25	90672-SA0-003	STRAP, CABLE, 118MM(BLACK) ..	1	(1)	-	-----	ED7,LHE,LHE/A,LKE,LKE/A,LXE,LXE/A,LXE4,LXE4/A,LXE6,LXE8,LXE8/A PXE8,PXE8/A,QAE6,QAE6/A,QHE,QHE/A,QME0,QME0/A,QME8,QME8/A,QNE6 QNR6,QNR6/A,QXE,QXE/A,QXEB,QXE4,QXE4/A,QXE6,QXE6/A,QXE8,QXE8/A SHE,SHEZ,SMEO,SMEO/A,SXE,SXE/A,SXEB,SXEB/A,SXE4,SXE4/A,SXE8 SXE8/A,S1,S1/A,VAAE,VEB6,VHE,VMQ,VMT,VMT/A,VNG2,VXEB,VXEB/A,VXE4 VXE6,VXE7,VXE7/A,VXE8,VXE8/A,VXU1,VXU1/A
26	91406-ZE2-003	TUBE, FASTENER, 30MM .....	1	(1)	-	-----	ED7,LHE,LHE/A,LKE,LKE/A,LXE,LXE/A,LXE4,LXE4/A,LXE6,LXE8,LXE8/A PXE8,PXE8/A,QAE6,QAE6/A,QHE,QHE/A,QME0,QME0/A,QME8,QME8/A,QNE6 QNR6,QNR6/A,QXE,QXE/A,QXEB,QXE4,QXE4/A,QXE6,QXE6/A,QXE8,QXE8/A SHE,SHEZ,SMEO,SMEO/A,SXE,SXE/A,SXEB,SXEB/A,SXE4,SXE4/A,SXE8 SXE8/A,S1,S1/A,VAAE,VEB6,VHE,VMQ,VMT,VMT/A,VNG2,VXEB,VXEB/A,VXE4 VXE6,VXE7,VXE7/A,VXE8,VXE8/A,VXU1,VXU1/A
27	93500-03012-0H	SCREW, PAN, 3X12 .....	2	(2)	-	-----	ED7,LHE,LHE/A,LXE,LXE/A,LXE4,LXE4/A,LXE6,LXE8,LXE8/A,PXE8,PXE8/A QAE6,QAE6/A,QHE,QHE/A,QXE,QXE/A,QXEB,QXE4,QXE4/A,QXE6,QXE6/A,QXE8 QXE8/A,SHE,SHEZ,SXE,SXE/A,SXEB,SXEB/A,SXE4,SXE4/A,SXE8,SXE8/A,S1 S1/A,VAAE,VEB6,VHE,VMQ,VMT,VMT/A,VNG2,VXEB,VXEB/A,VXE4,VXE6,VXE7 VXE7/A,VXE8,VXE8/A,VXU1,VXU1/A
			2	-	-	2398545 2566230	LKE





Ref. No.	Part No.	Description	Reqd. QTY			Serial No.	Parts catalogue code
			(1)	(2)	(3)		
28	93500-04012-0H	SCREW, PAN, 4X12 .....	1	(1)	-		ED7,LHE,LHE/A,LKE,LKE/A,LXE,LXE/A,LXE4,LXE4/A,LXE6,LXE8,LXE8/A PX8,PXE8/A,QAE6,QAE6/A,QHE,QHE/A,QMEO,QMEO/A,QME8,QME8/A,QNE6 QNR6,QNR6/A,QXE,QXE/A,QXEB,QXE4,QXE4/A,QXE6,QXE6/A,QXE8,QXE8/A SHE,SHEZ,SMEO,SMEO/A,SXE,SXE/A,SXEB,SXEB/A,SXE4,SXE4/A,SXE8 SXE8/A,S1,S1/A,VAAE,VEB6,VHE,VMQ,VMT,VMT/A,VNG2,VXEB,VXEB/A,VXE4 VXE6,VXE7,VXE7/A,VXE8,VXE8/A,VXU1,VXU1/A
29	94001-04390-0S	NUT, HEX., 4MM .....	1	(1)	-		ED7,LHE,LHE/A,QHE,QHE/A,QNE6,QXEB,SHE,SHEZ,S1,S1/A,VAAE,VEB6,VHE VNG2,VXE6
			1	-	-	2801237	LKE,LXE,LXE4,LXE6,QAE6,QMEO,QNR6,QXE,QXE4,QXE6,SMEO,SXE,SXEB,SXE4 VXEB,VXE4,VXU1
			2	-	-		LKE/A,LXE/A,LXE4/A,LXE8,LXE8/A,PXE8,PXE8/A,QAE6/A,QMEO/A,QME8 QME8/A,QNR6/A,QXE/A,QXE4/A,QXE6/A,QXE8,QXE8/A,SMEO/A,SXE/A,SXEB/A SXE4/A,SXE8,SXE8/A,VMQ,VMT,VMT/A,VXEB/A,VXE7/VXE7/A,VXE8,VXE8/A VXU1/A
30	94111-04800	WASHER, SPRING, 4MM .....	2	-	-	2801238	LKE,LXE,LXE4,LXE6,QAE6,QMEO,QNR6,QXE,QXE4,QXE6,SMEO,SXE,SXEB,SXE4 VXEB,VXE4,VXU1
			1	(1)	-		ED7,LHE,LHE/A,LKE,LKE/A,LXE,LXE/A,LXE4,LXE4/A,LXE6,LXE8,LXE8/A PX8,PXE8/A,QAE6,QAE6/A,QHE,QHE/A,QMEO,QMEO/A,QME8,QME8/A,QNE6 QNR6,QNR6/A,QXE,QXE/A,QXEB,QXE4,QXE4/A,QXE6,QXE6/A,QXE8,QXE8/A SHE,SHEZ,SMEO,SMEO/A,SXE,SXE/A,SXEB,SXEB/A,SXE4,SXE4/A,SXE8 SXE8/A,S1,S1/A,VAAE,VEB6,VHE,VMQ,VMT,VMT/A,VNG2,VXEB,VXEB/A,VXE4 VXE6,VXE7,VXE7/A,VXE8,VXE8/A,VXU1,VXU1/A
31	98200-31500	FUSE, BLADE (15A) .....	1	(1)	-		QAE6,QAE6/A,QMEO,QMEO/A,QME8,QME8/A,QNE6,SMEO,SMEO/A,S1,S1/A,VNG2
	98200-32500	FUSE, BLADE (25A) .....	1	-	-	2398544	LKE
	98200-30500	FUSE, BLADE (5A) .....	1	(1)	-		QNR6,QNR6/A
				1	-	-	ED7,ETS,LHE,LHE/A,LXE,LXE/A,LXE4,LXE4/A,LXE6,LXE8,LXE8/A,PXE8 PX8/A,QHE,QHE/A,QXE,QXE/A,QXEB,QXE4,QXE4/A,QXE6,QXE6/A,QXE8 QXE8/A,SHE,SHEZ,SXE,SXE/A,SXEB,SXEB/A,SXE4,SXE4/A,SXE8,SXE8/A,S1 S1/A,VAAE,VEB6,VHE,VMQ,VMT,VMT/A,VXEB,VXEB/A,VXE4,VXE6,VXE7 VXE7/A,VXE8,VXE8/A,VXU1,VXU1/A
	98200-31500	FUSE, BLADE (15A) .....	1	-	-	2398545	2566230 LKE
			1	-	-	2566231	LKE/A
			1	-	-		LKE
32	34150-ZH7-003	ALERT UNIT, OIL .....	1	-	-		LKE/A,LXE4/A,LXE8,LXE8/A,PXE8,PXE8/A,QAE6/A,QMEO/A,QME8,QME8/A QNR6/A,QXE4/A,QXE6/A,QXE8,QXE8/A,SMEO/A,SXEB/A,SXE4/A,SXE8,SXE8/A VMT,VXEB/A,VXE7,VXE7/A,VXE8,VXE8/A,VXU1/A
			1	-	-	2801238	LKE,LXE,LXE4,LXE6,QAE6,QMEO,QNR6,QXE,QXE4,QXE6,SMEO,SXE,SXEB,SXE4 VXEB,VXE4,VXU1
			1	-	-	4074558	LXE/A,QXE/A,SXE/A,VMQ,VMT/A
	34150-ZH7-013	.....	1	-	-	4074559	LXE/A,QXE/A,SXE/A,VMQ,VMT/A
33	94101-04800	WASHER, PLAIN, 4MM .....	1	-	-		LKE/A,LXE/A,LXE4/A,LXE8,LXE8/A,PXE8,PXE8/A,QAE6/A,QMEO/A,QME8 QME8/A,QNR6/A,QXE/A,QXE4/A,QXE6/A,QXE8,QXE8/A,SMEO/A,SXE/A,SXEB/A SXE4/A,SXE8,SXE8/A,VMQ,VMT,VMT/A,VXEB/A,VXE7,VXE7/A,VXE8,VXE8/A VXU1/A
			1	-	-	2801238	LKE,LXE,LXE4,LXE6,QAE6,QMEO,QNR6,QXE,QXE4,QXE6,SMEO,SXE,SXEB,SXE4 VXEB,VXE4,VXU1



E-23-1

CONTROL BOX(2)

2-G16

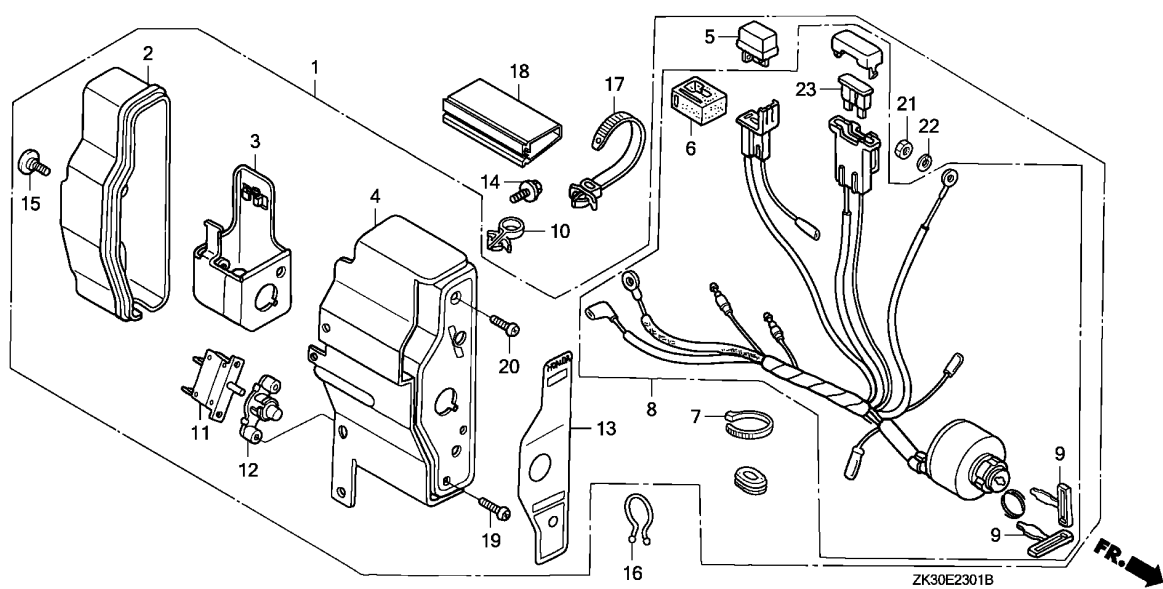

Ref. No.	L.O.N.	(Relative ref. Number) Description	F.R.T.
1	6221N7	BOX, ENGINE CONTROL .....	0.1
4	6221P7	PANEL, ENGINE CONTROL .....	0.2
5	6131B8	RECTIFIER, SILICON .....	0.1
8	6151E1	SWITCH, COMBINATION .....	0.2
11	6221D4	PROTECTOR, CIRCUIT .....	0.2
23	8121A7	FUSE, BLADE .....	0.1

Ref. No.	Part No.	Description	Reqd. QTY			Serial No.	Parts catalogue code
			GX	(1)	(2)		
1	31610-ZE3-013ZB	BOX ASSY., CONTROL (INTERNAL) *R8*.....BRIGHT RED	1	(1)	-	-----	L1,P1,Q1,SDE,SKE,S1,V1
			1	-	-	3672611	SKE/A
			-	(1)	-	3663624	L1/A,P1/A,Q1/A,S1/A
	31610-ZE3-013ZD	*R280*.....POWER RED	1	-	-	3672612	SKE/A
			-	(1)	-	3663625	L1/A,P1/A,Q1/A,S1/A
2	31612-ZE2-003	CASE, CONTROL .....	1	-	-	-----	SDE,SKE,SKE/A
			-	(1)	-	-----	-----
3	31614-ZE2-003	BRACKET, CASE MOUNTING .....	1	-	-	-----	SDE,SKE,SKE/A
			-	(1)	-	-----	-----
4	31615-ZE3-003ZB	PANEL COMP., CONTROL *R8*.....BRIGHT RED	1	(1)	-	-----	L1,P1,Q1,SDE,SKE,S1,V1
			1	(1)	-	3662149	L1/A,P1/A,Q1/A,SKE/A,S1/A
	31615-ZE3-003ZE	*R280*.....POWER RED	1	(1)	-	3662150	L1/A,P1/A,Q1/A,SKE/A,S1/A
5	31700-124-008	RECTIFIER ASSY., SILICON (SHINDENGEN)	1	-	-	-----	SDE,SKE,SKE/A
			-	(1)	-	-----	-----
6	32127-738-700	SUSPENSION, COUPLER .....	1	-	-	-----	SDE,SKE,SKE/A
			-	(1)	-	-----	-----
7	32902-892-003	BAND .....	1	-	-	-----	SDE,SKE,SKE/A
			-	(1)	-	-----	-----
8	35100-ZE2-023	SWITCH ASSY., COMBINATION ...	1	(1)	-	-----	L1,P1,Q1,SDE,SKE,S1,V1
			1	(1)	-	4077286	L1/A,P1/A,Q1/A,SKE/A,S1/A
	35100-ZE2-033	.....	1	(1)	-	4077287	L1/A,P1/A,Q1/A,SKE/A,S1/A
	35111-880-003	KEY COMP. ....	2	(2)	-	-----	L1,P1,Q1,SKE,S1,V1
			2	(2)	-	3792398	L1/A,P1/A,Q1/A,SKE/A,S1/A
			2	-	-	3838382	SDE

2

Ref. No.	Part No.	Description	Reqd. QTY			Serial No.	Parts catalogue code
			(1)	(2)	(3)		
(9)	35111-880-013	KEY COMP. ....	2	(2)	-	3792399 -----	L1/A,P1/A,Q1/A,SKE/A,S1/A
			2	-	-	3838383 -----	SDE
10	36103-ZE1-000	HOLDER, STOP SWITCH CORD ....	1	-	-	-----	SDE,SKE,SKE/A
			-	(1)	-		
11	38240-VA3-900	PROTECTOR, CIRCUIT (1.0A) ...	1	-	-	-----	SDE,SKE,SKE/A
			-	(1)	-		
12	38250-ZA8-701	LENS ASSY., PROTECTOR ....	1	-	-	-----	SDE,SKE,SKE/A
			-	(1)	-		
13	87529-ZE2-010	PANEL, CONTROL BOX (INTERNAL)	1	(1)	-	-----	L1,P1,P1/A,Q1,Q1/A,SDE,SKE,S1,V1
	87529-ZE2-020	.....	1	(1)	-	3735552 -----	L1/A,SKE/A,S1/A
14	90013-883-000	BOLT, FLANGE, 6X12(CT200) ...	2	-	-	-----	SDE,SKE,SKE/A
			-	(2)	-		
15	90380-MA6-010	SCREW, SPECIAL, 6X12 ....	1	-	-	-----	SDE,SKE,SKE/A
			-	(1)	-		
16	90630-751-000	CLIP, PURSE LOCK .....	1	-	-	-----	SDE,SKE,SKE/A
			-	(1)	-		
17	90672-SAO-003	STRAP, CABLE, 118MM(BLACK) ..	1	-	-	-----	SDE,SKE,SKE/A
			-	(1)	-		
18	91406-ZE2-003	TUBE, FASTENER, 30MM .....	1	-	-	-----	SDE,SKE,SKE/A
			-	(1)	-		
19	93500-03012-0H	SCREW, PAN, 3X12 .....	2	-	-	-----	SDE,SKE,SKE/A
			-	(2)	-		
20	93500-04012-0H	SCREW, PAN, 4X12 .....	1	-	-	-----	SDE,SKE,SKE/A
			-	(1)	-		
21	94001-04390-0S	NUT, HEX., 4MM .....	1	-	-	-----	SDE,SKE,SKE/A
			-	(1)	-		
22	94111-04800	WASHER, SPRING, 4MM .....	1	-	-	-----	SDE,SKE,SKE/A
			-	(1)	-		
23	98200-30500	FUSE, BLADE (5A) .....	1	-	-	-----	SDE,SKE,SKE/A
			-	(1)	-		



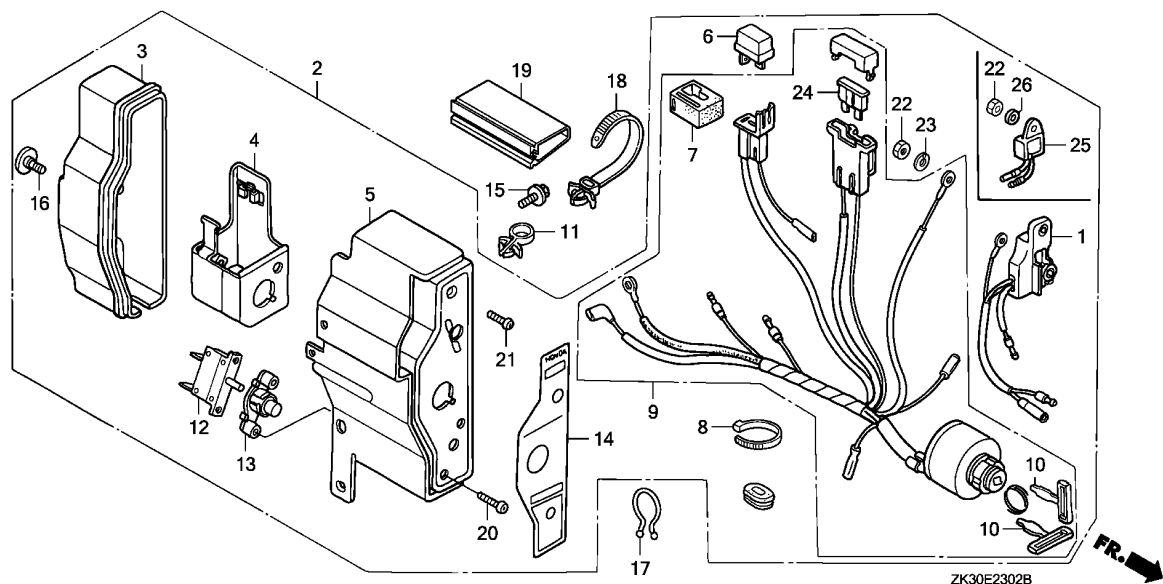

Ref. No.	L.O.N.	(Relative ref. Number) Description	F.R.T.
1		(25)	
1	6151K4	ALERT UNIT, ENGINE CONTROL OIL	0.2
2	6221N7	BOX, ENGINE CONTROL	0.1
5	6221P7	PANEL, ENGINE CONTROL	0.2
6	6131B8	RECTIFIER, SILICON	0.1
9	6151E1	SWITCH, COMBINATION	0.2
12	6221D4	PROTECTOR, CIRCUIT	0.2
24	8121A7	FUSE, BLADE	0.1



Ref. No.	Part No.	Description	Reqd. QTY			Serial No.	Parts catalogue code
			GX	340K1			
			(1)	(2)	(3)		
1	15520-ZE2-822	ALERT UNIT, OIL (SEL)	-	(1)	-	2143683	L1,P1,Q1,S1,V1
2	31610-ZE3-W01ZB	BOX ASSY., CONTROL (INTERNAL-ALERT)	-	(1)	-	2143683	L1,P1,Q1,S1,V1
		*R8*.....BRIGHT RED	-	(1)	-	2143684	V1
	31610-ZE3-W02ZB	*R8*.....BRIGHT RED	-	(1)	-	2143684	2801237 L1,P1,Q1,S1
	31610-ZE3-W33ZA	BOX ASSY., CONTROL (EXP-ALERT) (10A)	-	(1)	-		S1/A
		*NH1*.....BLACK	-	(1)	-	2801238	S1
	31610-ZE3-W33ZB	*R8*.....BRIGHT RED	-	(1)	-	2801238	L1,P1,Q1,S1
			-	(1)	-	3663624	L1/A,P1/A,Q1/A,S1/A
	31610-ZE3-W33ZD	*R280*.....POWER RED	-	(1)	-	3663625	L1/A,P1/A,Q1/A,S1/A
3	31612-ZE2-003	CASE, CONTROL	-	(1)	-		
4	31614-ZE2-003	BRACKET, CASE MOUNTING	-	(1)	-		
5	31615-ZE3-003ZB	PANEL COMP., CONTROL	-	(1)	-		
		*R8*.....BRIGHT RED	-	(1)	-	3662149	L1,P1,Q1,S1,V1
			-	(1)	-	3662150	L1/A,P1/A,Q1/A,S1/A
	31615-ZE3-003ZE	*R280*.....POWER RED	-	(1)	-	3662150	L1/A,P1/A,Q1/A,S1/A
6	31700-124-008	RECTIFIER ASSY., SILICON (SHINDENGEN)	-	(1)	-		
7	32127-738-700	SUSPENSION, COUPLER	-	(1)	-		
8	32902-892-003	BAND	-	(1)	-		
9	35100-ZE2-023	SWITCH ASSY., COMBINATION	-	(1)	-		L1,P1,P1/A,Q1,S1,V1
			-	(1)	-	4077286	L1/A,Q1/A,S1/A
	35100-ZE2-033		-	(1)	-	4077287	L1/A,Q1/A,S1/A
10	35111-880-003	KEY COMP.	-	(2)	-		L1,P1,Q1,S1,V1
			-	(2)	-	3792398	L1/A,P1/A,Q1/A,S1/A

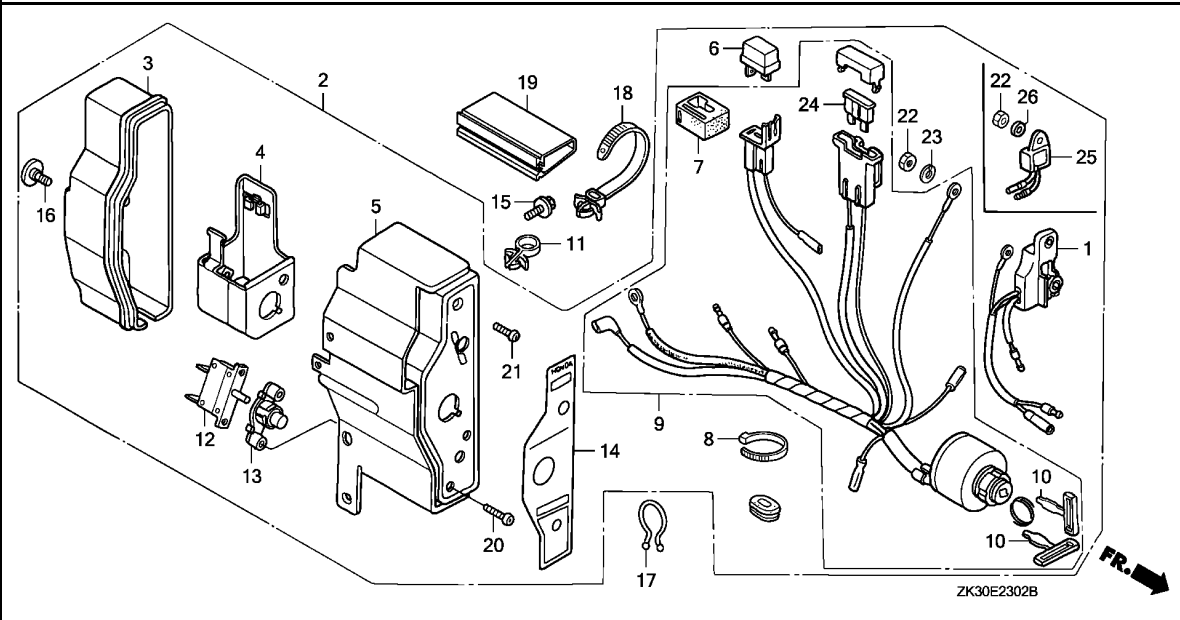

Ref. No.	Part No.	Description	Reqd. QTY			Serial No.	Parts catalogue code
			GX	340K1	(3)		
10)	35111-880-013	KEY COMP. ....	-	(2)	-	3792399	----- L1/A,P1/A,Q1/A,S1/A
	11	36103-ZE1-000	HOLDER, STOP SWITCH CORD ....	-	(1)	-	
	12	38240-VA3-900	PROTECTOR, CIRCUIT (1.0A) ...	-	(1)	-	
	13	38250-ZA8-701	LENS ASSY., PROTECTOR .....	-	(1)	-	
	14	87529-ZE2-821	PANEL, CONTROL BOX (INTERNAL-ALERT)	-	(1)	-	2143683 L1,P1,Q1,S1,V1
	87529-ZE2-010	PANEL, CONTROL BOX (INTERNAL)	-	(1)	-	2143684	----- P1/A,Q1/A
			-	(1)	-	3735552	----- L1,P1,Q1,S1,V1
	87529-ZE2-020	.....	-	(1)	-	3735553	----- L1/A,S1/A
	15	90013-883-000	BOLT, FLANGE, 6X12(CT200) ...	-	(1)	-	
	16	90380-MA6-010	SCREW, SPECIAL, 6X12 .....	-	(1)	-	
	17	90630-751-000	CLIP, PURSE LOCK .....	-	(1)	-	
	18	90672-SA0-003	STRAP, CABLE, 118MM(BLACK) ..	-	(1)	-	
	19	91406-ZE2-003	TUBE, FASTENER, 30MM .....	-	(1)	-	
	20	93500-03012-0H	SCREW, PAN, 3X12 .....	-	(2)	-	
	21	93500-04012-0H	SCREW, PAN, 4X12 .....	-	(1)	-	
	22	94001-04390-0S	NUT, HEX., 4MM .....	-	(2)	-	
	23	94111-04800	WASHER, SPRING, 4MM .....	-	(1)	-	
	24	98200-30500	FUSE, BLADE (5A) .....	-	(1)	-	
	25	34150-ZH7-003	ALERT UNIT, OIL .....	-	(1)	-	----- L1,P1,P1/A,Q1,Q1/A,S1,V1
			-	(1)	-	4074558	----- L1/A,S1/A
	34150-ZH7-013	.....	-	(1)	-	4074559	----- L1/A,S1/A
	26	94101-04800	WASHER, PLAIN, 4MM .....	-	(1)	-	



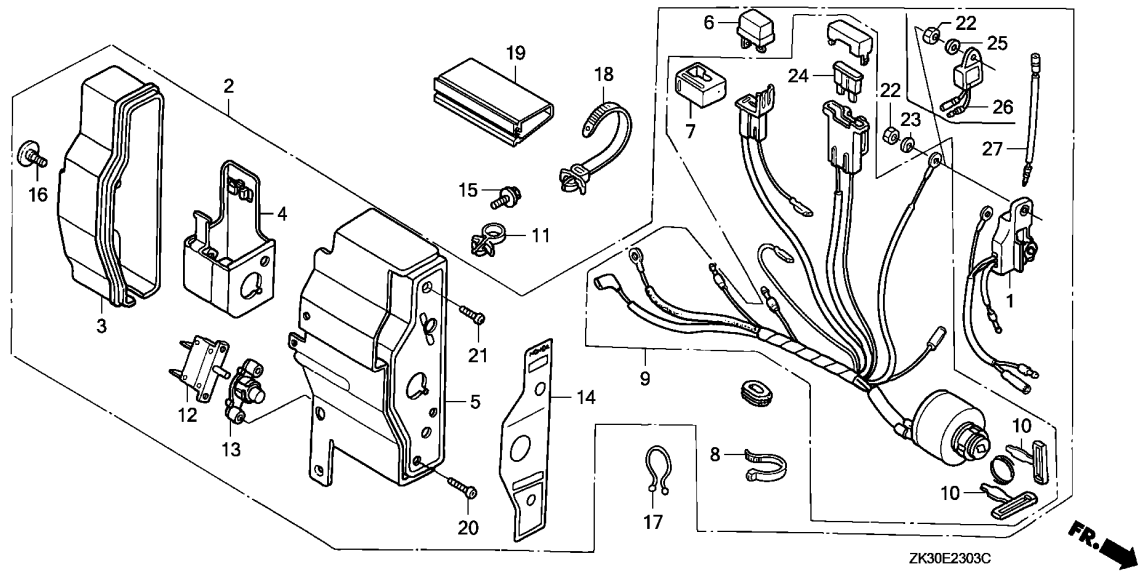

Ref. No.	L.O.N.	(Relative ref. Number) Description	F.R.T.
1		(26)	
1	6151K4	ALERT UNIT, ENGINE CONTROL OIL	0.2
2	6221N7	BOX, ENGINE CONTROL	0.1
5	6221P7	PANEL, ENGINE CONTROL	0.2
6	6131B8	RECTIFIER, SILICON	0.1
9	6151E1	SWITCH, COMBINATION	0.2
12	6221D4	PROTECTOR, CIRCUIT	0.2
24	8121A7	FUSE, BLADE	0.1

2

Ref. No.	Part No.	Description	Reqd. QTY			Serial No.	Parts catalogue code
			GX	340K1			
			(1)	(2)	(3)		
1	15520-ZE2-822	ALERT UNIT, OIL (SEL) .....	1	-	-	2143683	QAE,VAH2,VXE
2	31610-ZE3-W11ZB	BOX ASSY., CONTROL (ALERT)	1	-	-	2143683	VAH2,VXE
	*R8*	.....BRIGHT RED	1	-	-		
	31610-ZE3-W12ZB	BOX ASSY., CONTROL	1	-	-	2143684	VAH2
	*R8*	.....BRIGHT RED	1	-	-	2143684	2801237 VXE
	31610-ZE3-W21ZB	BOX ASSY., CONTROL (ALERT)(3A)	1	-	-	2143683	QAE
	*R8*	.....BRIGHT RED	1	-	-	2143684	QAE
	31610-ZE3-W22ZB	BOX ASSY., CONTROL (3A)	1	-	-	2143684	QAE
	*R8*	.....BRIGHT RED	1	-	-		
	31610-ZE3-W13ZB	BOX ASSY., CONTROL (ALERT)	1	-	-	2801238	VXE
	*R8*	.....BRIGHT RED	1	-	-	3662261	VXE/A
	31610-ZE3-W13ZC	*T39*.....GEKO BLUE	1	-	-		VXE/A
			1	-	-	2801238	VXE
	31610-ZE3-W13ZD	*NH105*...MAT BLACK (#15-#20)	1	-	-		VXE/A
			1	-	-	2801238	VXE
	31610-ZE3-W13ZE	BOX ASSY., CONTROL	1	-	-	3662262	VXE/A
	*R280*	.....POWER RED	1	-	-		VXE/A
3	31612-ZE2-003	CASE, CONTROL .....	1	-	-		QAE,VAH2,VXE,VXE/A
4	31614-ZE2-003	BRACKET, CASE MOUNTING .....	1	-	-		QAE,VAH2,VXE,VXE/A
5	31615-ZE3-003ZB	PANEL COMP., CONTROL	1	-	-		QAE,VAH2,VXE
	*R8*	.....BRIGHT RED	1	-	-	3662149	VXE/A
	31615-ZE3-003ZC	*T39*.....GEKO BLUE	1	-	-		VXE/A
			1	-	-	2801238	VXE
	31615-ZE3-003ZD	*NH105*...MAT BLACK (#15-#20)	1	-	-		VXE/A
			1	-	-	2801238	VXE
	31615-ZE3-003ZE	*R280*.....POWER RED	1	-	-	3662150	VXE/A

Ref. No.	Part No.	Description	Reqd. QTY			Serial No.	Parts catalogue code
			(1)	(2)	(3)		
6	31700-124-008	RECTIFIER ASSY., SILICON (SHINDENGEN)	1	-	-	-----	QAE,VAH2,VXE,VXE/A
7	32127-738-700	SUSPENSION, COUPLER .....	1	-	-	-----	QAE,VAH2,VXE,VXE/A
8	32902-892-003	BAND .....	1	-	-	-----	QAE,VAH2,VXE,VXE/A
9	35100-ZE2-023	SWITCH ASSY., COMBINATION ...	1	-	-	-----	VAH2,VXE
	35100-ZE2-842	SWITCH ASSY., COMBINATION (3A-CHARGE)	1	-	-	4077286	VXE/A
	35100-ZE2-033	SWITCH ASSY., COMBINATION ...	1	-	-	4077287	VXE/A
10	35111-880-003	KEY COMP. ....	2	-	-	-----	QAE,VAH2,VXE
	35111-880-013	.....	2	-	-	3792398	VXE/A
	35111-880-013	.....	2	-	-	3792399	VXE/A
11	36103-ZE1-000	HOLDER, STOP SWITCH CORD ....	1	-	-	-----	QAE,VAH2,VXE,VXE/A
12	38240-VA3-900	PROTECTOR, CIRCUIT (1.0A) ...	1	-	-	-----	VAH2,VXE,VXE/A
	38240-ZE2-840	PROTECTOR, CIRCUIT (3.5A) ...	1	-	-	-----	QAE
13	38250-ZA8-701	LENS ASSY., PROTECTOR .....	1	-	-	-----	QAE,VAH2,VXE,VXE/A
14	87529-ZE2-831	PANEL, CONTROL BOX (EXTERNAL-ALERT)	1	-	-	2143683	QAE,VAH2,VXE
	87529-ZE2-811	MARK, CONTROL BOX (EXTERNAL)	1	-	-	2143684	QAE,VAH2,VXE
	87529-ZE2-812	MARK, CONTROL BOX (EXP) .....	1	-	-	3723964	VXE/A
15	90013-883-000	BOLT, FLANGE, 6X12(CT200) ...	2	-	-	3723965	VXE/A
	90013-883-000	.....	2	-	-	-----	QAE,VAH2,VXE,VXE/A
16	90380-MA6-010	SCREW, SPECIAL, 6X12 .....	1	-	-	-----	QAE,VAH2,VXE,VXE/A
17	90630-751-000	CLIP, PURSE LOCK .....	1	-	-	-----	QAE,VAH2,VXE,VXE/A
18	90672-SA0-003	STRAP, CABLE, 118MM(BLACK) ..	1	-	-	-----	QAE,VAH2,VXE,VXE/A
19	91406-ZE2-003	TUBE, FASTENER, 30MM .....	1	-	-	-----	QAE,VAH2,VXE,VXE/A
20	93500-03012-OH	SCREW, PAN, 3X12 .....	2	-	-	-----	QAE,VAH2,VXE,VXE/A
21	93500-04012-OH	SCREW, PAN, 4X12 .....	1	-	-	-----	QAE,VAH2,VXE,VXE/A
22	94001-04390-OS	NUT, HEX., 4MM .....	1	-	-	-----	QAE,VAH2
	94001-04390-OS	.....	1	-	-	2801237	VXE
	94001-04390-OS	.....	2	-	-	-----	VXE/A
	94001-04390-OS	.....	2	-	-	2801238	VXE
23	94111-04800	WASHER, SPRING, 4MM .....	1	-	-	-----	QAE,VAH2,VXE,VXE/A
24	98200-30500	FUSE, BLADE (5A) .....	1	-	-	-----	VAH2,VXE,VXE/A
	98200-31500	FUSE, BLADE (15A) .....	1	-	-	-----	QAE
25	94101-04800	WASHER, PLAIN, 4MM .....	1	-	-	-----	VXE/A
	94101-04800	.....	1	-	-	2801238	VXE
26	34150-ZH7-003	ALERT UNIT, OIL .....	1	-	-	2801238	VXE
	34150-ZH7-003	.....	1	-	-	4074558	VXE/A
	34150-ZH7-013	.....	1	-	-	4074559	VXE/A
27	32197-ZE1-003	SUB HARNESS .....	1	-	-	-----	VXE/A
	32197-ZE1-003	.....	1	-	-	2143684	QAE,VAH2,VXE



E-23-4

CONTROL BOX(5)

2-H 6

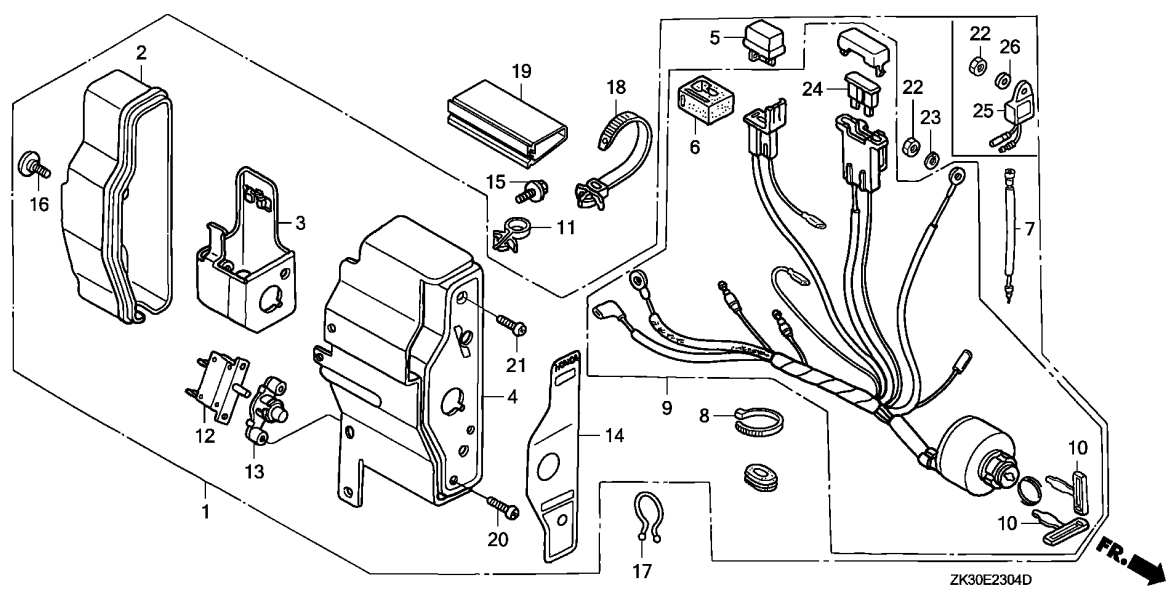

Ref. No.	L.O.N.	(Relative ref. Number) Description	F.R.T.
1	6221N7	BOX, ENGINE CONTROL .....	0.1
4	6151K5	PANEL, ENGINE CONTROL. ....	0.2
5	6131B8	RECTIFIER, SILICON .....	0.1
9	6151E1	SWITCH, COMBINATION .....	0.2
12	6221D4	PROTECTOR, CIRCUIT .....	0.2
24	8121A7	FUSE, BLADE .....	0.1
25	6151K4	ALERT UNIT, ENGINE CONTROL OIL	0.2

2

Ref. No.	Part No.	Description	Reqd. QTY			Serial No.	Parts catalogue code
			GX	(1)	(2)		
1	31610-ZE3-W12ZA	BOX ASSY., CONTROL	1	-	-	-	SME2
	*NH1*	.....BLACK	1	-	-	-	SME2,SXE2
	31610-ZE3-W12ZB	*R8*.....BRIGHT RED	1	-	-	2801237	LXE2,QXE2,VH22,VXE2
	31610-ZE3-W12ZD	*NH105*...MAT BLACK (#15-#20)	1	-	-	2801237	VWE2,VXE2
	31610-ZE3-W13ZB	BOX ASSY., CONTROL (ALERT)	1	-	-	2801238	LXE2,QXE2,VH22,VXE2
	*R8*	.....BRIGHT RED	1	-	-	3671095	LXE2/A,VH22/A,VXE2/A
	31610-ZE3-W22ZB	BOX ASSY., CONTROL (3A)	1	-	-	2801237	QAE2
	*R8*	.....BRIGHT RED	1	-	-	-	VWE2/A,VXE2/A
	31610-ZE3-W13ZD	BOX ASSY., CONTROL (ALERT)	1	-	-	2801238	VWE2,VXE2
	*NH105*	...MAT BLACK (#15-#20)	1	-	-	-	VWE2,VXE2
	31610-ZE3-W13ZE	BOX ASSY., CONTROL	1	-	-	3671096	LXE2/A,VH22/A,VXE2/A
	*R280*	.....POWER RED	1	-	-	-	QAE2/A
	31610-ZE3-W23ZA	BOX ASSY., CONTROL (ALERT) (3A)	1	-	-	2801238	QAE2
	*NH1*	.....BLACK	1	-	-	2801238	QAE2
	31610-ZE3-W23ZB	*R8*.....BRIGHT RED	1	-	-	3662149	QAE2/A
	31610-ZE3-W23ZD	BOX ASSY., CONTROL (EXP-ALERT) (3A)	1	-	-	-	QAE2/A
	*R280*	.....POWER RED	1	-	-	3662150	QAE2/A
2	31612-ZE2-003	CASE, CONTROL .....	1	-	-	-	LXE2,LXE2/A,QAE2,QAE2/A,QXE2,SME2,SXE2,VH22,VH22/A,VWE2,VWE2/A
3	31614-ZE2-003	BRACKET, CASE MOUNTING .....	1	-	-	-	VXE2,VXE2/A
			1	-	-	-	LXE2,LXE2/A,QAE2,QAE2/A,QXE2,SME2,SXE2,VH22,VH22/A,VWE2,VWE2/A
4	31615-ZE3-003ZA	PANEL COMP., CONTROL	1	-	-	-	VXE2,VXE2/A
	*NH1*	.....BLACK	1	-	-	-	ENT,ENT/A,SME2



Ref. No.	Part No.	Description	Reqd. QTY			Serial No.	Parts catalogue code	
			(1)	(2)	(3)			
(4)	31615-ZE3-003ZB	PANEL COMP., CONTROL *R8*.....BRIGHT RED	1	-	-	-----	LXE2,QAE2,QXE2,SME2,SXE2,VH22,VXE2	
			1	-	-	3662149	LXE2/A,QAE2/A,VH22/A,VXE2/A	
	31615-ZE3-003ZD	*NH105*...MAT BLACK (#15-#20)	1	-	-	-----	VWE2,VWE2/A,VXE2,VXE2/A	
	31615-ZE3-003ZE	*R280*.....POWER RED	1	-	-	3662150	-----	LXE2/A,QAE2/A,VH22/A,VXE2/A
5	31700-124-008	RECTIFIER ASSY., SILICON (SHINDENGEN)	1	-	-	-----	LXE2,LXE2/A,QAE2,QAE2/A,QXE2,SME2,SXE2,VH22,VH22/A,VWE2,VWE2/A VXE2,VXE2/A	
6	32127-738-700	SUSPENSION, COUPLER .....	1	-	-	-----	LXE2,LXE2/A,QAE2,QAE2/A,QXE2,SME2,SXE2,VH22,VH22/A,VWE2,VWE2/A VXE2,VXE2/A	
7	32197-ZE1-003	SUB HARNESS .....	1	-	-	-----	LXE2,LXE2/A,QAE2,QAE2/A,QXE2,SME2,SXE2,VH22,VH22/A,VWE2,VWE2/A VXE2,VXE2/A	
8	32902-892-003	BAND .....	1	-	-	-----	LXE2,LXE2/A,QAE2,QAE2/A,QXE2,SME2,SXE2,VH22,VH22/A,VWE2,VWE2/A VXE2,VXE2/A	
9	35100-ZE2-023	SWITCH ASSY., COMBINATION ...	1	-	-	-----	LXE2,LXE2/A,QXE2,SME2,SXE2,VH22,VH22/A,VWE2,VWE2/A,VXE2,VXE2/A	
	35100-ZE2-842	SWITCH ASSY., COMBINATION (3A-CHARGE)	1	-	-	-----	QAE2,QAE2/A	
10	35111-880-003	KEY COMP. ....	2	-	-	-----	LXE2,QAE2,SME2,SXE2,VH22,VWE2,VXE2	
			2	-	-	3792398	LXE2/A,QAE2/A,VH22/A,VWE2/A,VXE2/A	
			2	-	-	3838382	QXE2	
	35111-880-013	.....	2	-	-	3792399	LXE2/A,QAE2/A,VH22/A,VWE2/A,VXE2/A	
			2	-	-	3838383	QXE2	
11	36103-ZE1-000	HOLDER, STOP SWITCH CORD ....	1	-	-	-----	LXE2,LXE2/A,QAE2,QAE2/A,QXE2,SME2,SXE2,VH22,VH22/A,VWE2,VWE2/A VXE2,VXE2/A	
12	38240-VA3-900	PROTECTOR, CIRCUIT (1.0A) ...	1	-	-	-----	LXE2,LXE2/A,QXE2,SME2,SXE2,VH22,VH22/A,VWE2,VWE2/A,VXE2,VXE2/A	
	38240-ZE2-840	PROTECTOR, CIRCUIT (3.5A) ...	1	-	-	-----	QAE2,QAE2/A	
13	38250-ZA8-701	LENS ASSY., PROTECTOR .....	1	-	-	-----	LXE2,LXE2/A,QAE2,QAE2/A,QXE2,SME2,SXE2,VH22,VH22/A,VWE2,VWE2/A VXE2,VXE2/A	
14	87529-ZE2-811	MARK, CONTROL BOX (EXTERNAL)	1	-	-	-----	LXE2,QAE2,QXE2,SME2,SXE2,VH22,VWE2,VXE2	
			1	-	-	3723964	LXE2/A,QAE2/A,VH22/A,VWE2/A,VXE2/A	
	87529-ZE2-812	MARK, CONTROL BOX (EXP) .....	1	-	-	3723965	LXE2/A,QAE2/A,VH22/A,VWE2/A,VXE2/A	
15	90013-883-000	BOLT, FLANGE, 6X12(CT200) ...	1	-	-	-----	QAE2,QAE2/A,QXE2,VXE2,VXE2/A	
			2	-	-	-----	LXE2,VH22,VWE2	
			2	-	-	2644833	SME2,SXE2	
16	90380-MA6-010	SCREW, SPECIAL, 6X12 .....	1	-	-	-----	LXE2,LXE2/A,QAE2,QAE2/A,QXE2,SME2,SXE2,VH22,VH22/A,VWE2,VWE2/A VXE2,VXE2/A	
17	90630-751-000	CLIP, PURSE LOCK .....	1	-	-	-----	LXE2,LXE2/A,QAE2,QAE2/A,QXE2,SME2,SXE2,VH22,VH22/A,VWE2,VWE2/A VXE2,VXE2/A	
18	90672-SA0-003	STRAP, CABLE, 118MM(BLACK) ..	1	-	-	-----	LXE2,LXE2/A,QAE2,QAE2/A,QXE2,SME2,SXE2,VH22,VH22/A,VWE2,VWE2/A VXE2,VXE2/A	
19	91406-ZE2-003	TUBE, FASTENER, 30MM .....	1	-	-	-----	LXE2,LXE2/A,QAE2,QAE2/A,QXE2,SME2,SXE2,VH22,VH22/A,VWE2,VWE2/A VXE2,VXE2/A	
20	93500-03012-OH	SCREW, PAN, 3X12 .....	2	-	-	-----	LXE2,LXE2/A,QAE2,QAE2/A,QXE2,SME2,SXE2,VH22,VH22/A,VWE2,VWE2/A VXE2,VXE2/A	
21	93500-04012-OH	SCREW, PAN, 4X12 .....	1	-	-	-----	LXE2,LXE2/A,QAE2,QAE2/A,QXE2,SME2,SXE2,VH22,VH22/A,VWE2,VWE2/A VXE2,VXE2/A	
22	94001-04390-0S	NUT, HEX., 4MM .....	1	-	-	-----	SME2,SXE2	
			1	-	-	2801237	LXE2,QAE2,QXE2,VH22,VWE2,VXE2	
			2	-	-	-----	LXE2/A,QAE2/A,VH22/A,VWE2/A,VXE2/A	
			2	-	-	2801238	LXE2,QAE2,QXE2,VH22,VWE2,VXE2	
23	94111-04800	WASHER, SPRING, 4MM .....	1	-	-	-----	LXE2,LXE2/A,QAE2,QAE2/A,QXE2,SME2,SXE2,VH22,VH22/A,VWE2,VWE2/A VXE2,VXE2/A	
24	98200-30500	FUSE, BLADE (5A) .....	1	-	-	-----	LXE2,LXE2/A,QXE2,SME2,SXE2,VH22,VH22/A,VWE2,VWE2/A,VXE2,VXE2/A	
	98200-31500	FUSE, BLADE (15A) .....	1	-	-	-----	QAE2,QAE2/A	



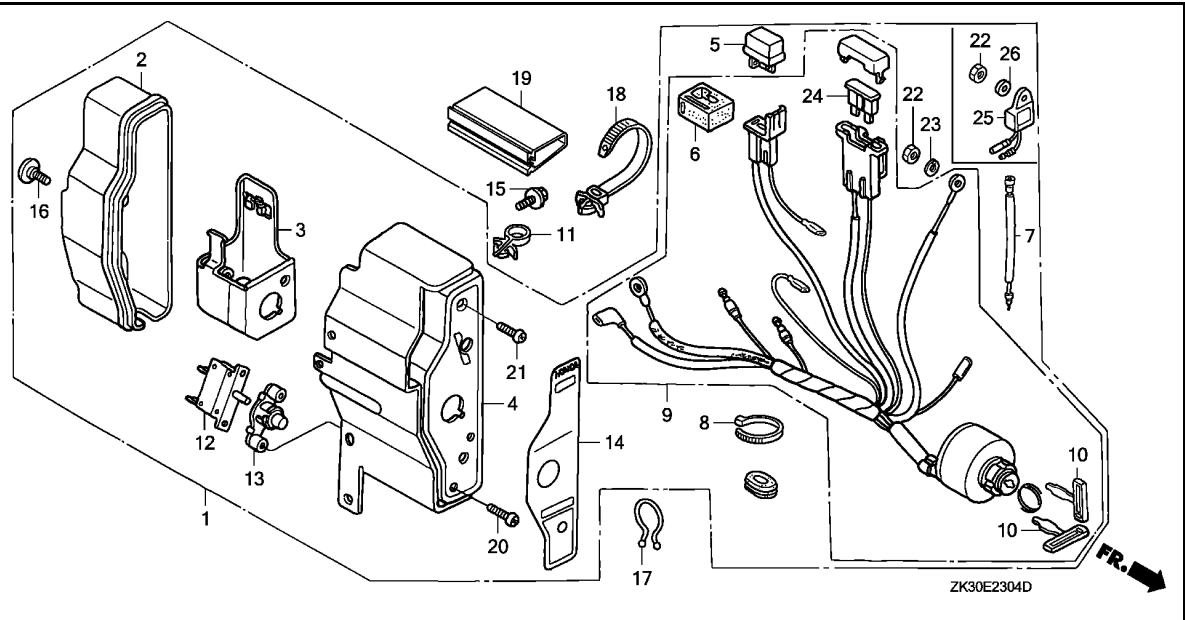

Ref. No.	Part No.	Description	Reqd. QTY			Serial No.	Parts catalogue code
			GX	340K1			
			(1)	(2)	(3)		
25	34150-ZH7-003	ALERT UNIT, OIL .....	1	-	-	----- LXE2/A,QAE2/A,VH22/A,VWE2/A,VXE2/A	
			1	-	-	2801238 ----- LXE2,QAE2,QXE2,VH22,VWE2,VXE2	
26	94101-04800	WASHER, PLAIN, 4MM .....	1	-	-	----- LXE2/A,QAE2/A,VH22/A,VWE2/A,VXE2/A	
			1	-	-	2801238 ----- LXE2,QAE2,QXE2,VH22,VWE2,VXE2	



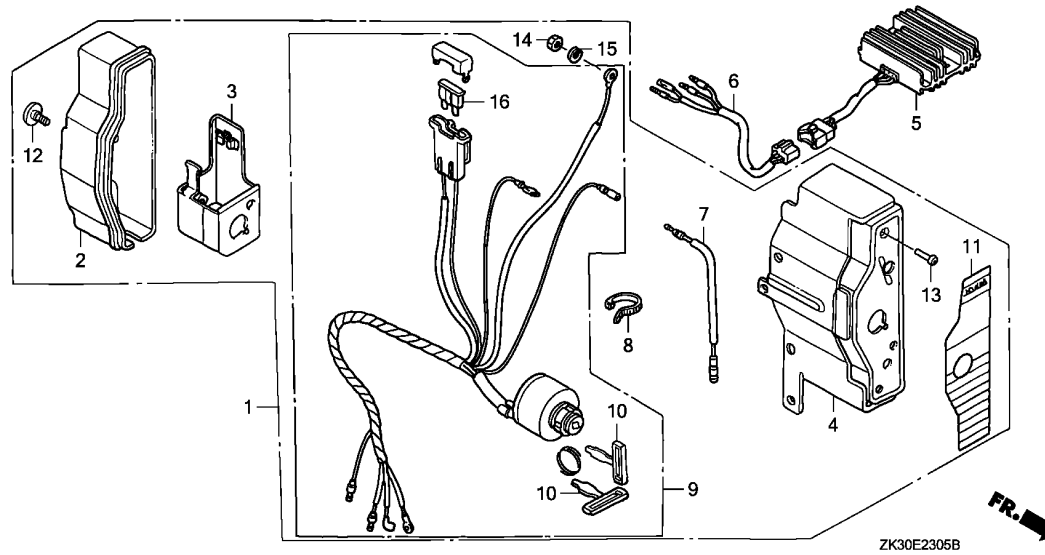

Ref. No.	L.O.N.	(Relative ref. Number) Description	F.R.T.
1	6221N7	BOX, ENGINE CONTROL .....	0.1
4	6221P7	PANEL, ENGINE CONTROL .....	0.2
5	6131B7	RECTIFIER, REGULATOR .....	0.2
6	6111E6	HARNESS, REGULATOR RECTIFIER ..	0.2
9	6151E1	SWITCH, COMBINATION .....	0.2
16	8121A7	FUSE, BLADE .....	0.1

Ref. No.	Part No.	Description	Reqd. QTY			Serial No.	Parts catalogue code
			GX	(1)	(2)		
1	31610-ZE3-W41ZB	BOX ASSY., CONTROL (18A)	-	(1)	-		
		*R8*.....BRIGHT RED	-	(1)	-		
	31610-ZE3-W42ZD	BOX ASSY., CONTROL (EXP-ALERT) (18A)	-	(1)	-		
2	31612-ZE2-003	CASE, CONTROL .....	-	(1)	-	3663625	----- L1/A,P1/A,Q1/A,S1/A
3	31614-ZE2-003	BRACKET, CASE MOUNTING .....	-	(1)	-		
4	31615-ZE3-003ZA	PANEL COMP., CONTROL	-	(1)	-		
		*NH1*.....BLACK	-	(1)	-		
	31615-ZE3-003ZB	*R8*.....BRIGHT RED	-	(1)	-		
		*R8*.....BRIGHT RED	-	(1)	-	3662149	----- L1/A,P1/A,Q1/A,S1/A
	31615-ZE3-003ZE	*R280*.....POWER RED	-	(1)	-	3662150	----- L1/A,P1/A,Q1/A,S1/A
5	31620-ZG5-003	RECTIFIER ASSY., REGULATOR (20A)	-	(1)	-		
6	32110-ZE2-W00	HARNESS ASSY., SUB WIRE .....	-	(1)	-		
7	32197-ZE1-003	SUB HARNESS .....	-	(1)	-		
8	32902-892-003	BAND .....	-	(1)	-		
9	35100-ZE2-W01	SWITCH ASSY., COMBINATION (18A-CHARGE)	-	(1)	-		
10	35111-880-003	KEY COMP. ....	-	(2)	-		
		.....	-	(2)	-	3792398	----- L1/A,P1/A,Q1/A,S1/A
	35111-880-013	.....	-	(2)	-	3792399	----- L1/A,P1/A,Q1/A,S1/A
11	87529-ZE2-860	MARK, CONTROL BOX (EXTERNAL-REGULATOR)	-	(1)	-		
		.....	-	(1)	-	3724889	----- L1/A,P1/A,Q1/S1,V1
	87529-ZE2-861	.....	-	(1)	-	3724890	----- L1/A,Q1/A,S1/A
12	90380-MA6-010	SCREW, SPECIAL, 6X12 .....	-	(1)	-		



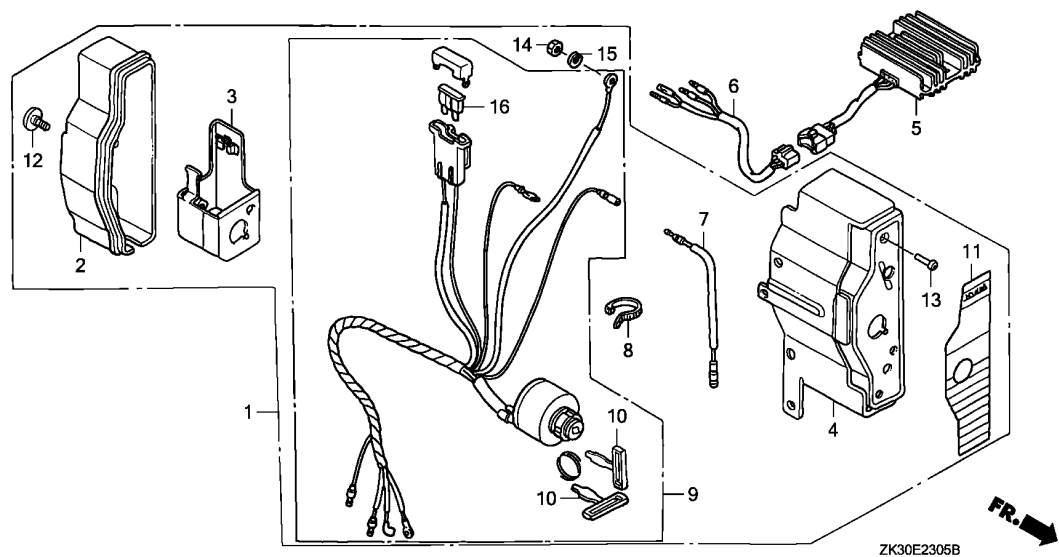

2

Ref. No.	Part No.	Description	Reqd. QTY			Serial No.	Parts catalogue code
			GX	340K1			
			(1)	(2)	(3)		
13	93500-04012-0H	SCREW, PAN, 4X12 .....	-	(1)	-		
14	94001-04390-OS	NUT, HEX., 4MM .....	-	(1)	-		
15	94111-04800	WASHER, SPRING, 4MM .....	-	(1)	-		
16	98200-32500	FUSE, BLADE (25A) .....	-	(1)	-		

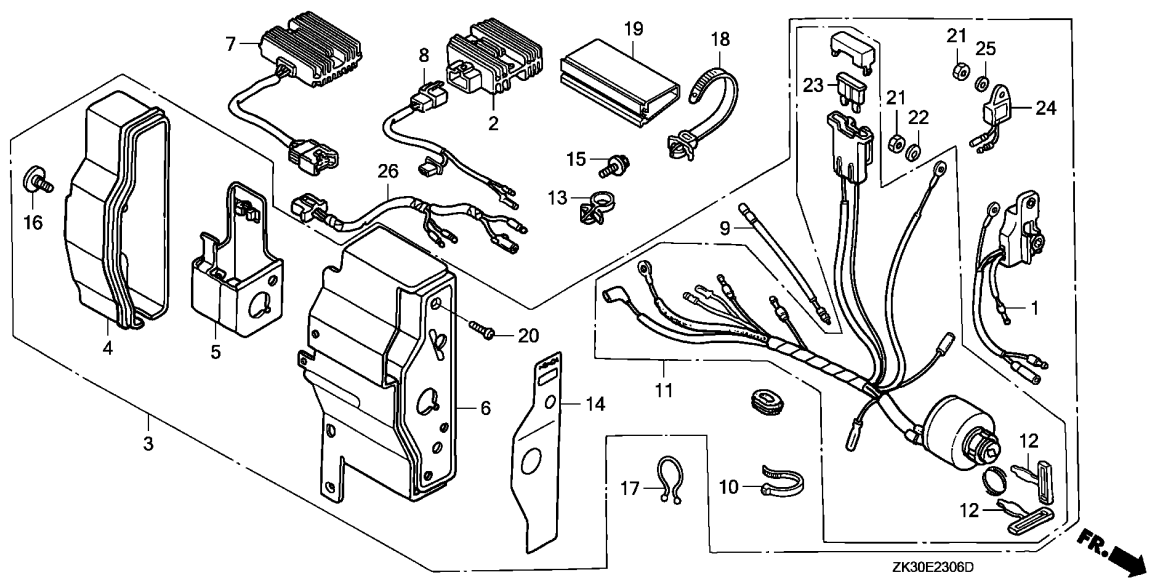

Ref. No.	L.O.N.	(Relative ref. Number) Description	F.R.T.
1		(24)	
1	6151K4	ALERT UNIT, ENGINE CONTROL OIL	0.2
2	6131B7	RECTIFIER, REGULATOR	0.2
3	6221N7	BOX, ENGINE CONTROL	0.1
6	6151K5	PANEL, ENGINE CONTROL	0.2
7	6131B7	RECTIFIER, REGULATOR	0.2
11	6151E1	SWITCH, COMBINATION	0.2
23	8121A7	FUSE, BLADE	0.1

Ref. No.	Part No.	Description	Reqd. QTY			Serial No.	Parts catalogue code
			GX	340K1			
			(1)	(2)	(3)		
1	15520-ZE2-822	ALERT UNIT, OIL (SEL)	1	-	-	2143683	QAPE,QNE
2	31600-ZE2-861	RECTIFIER ASSY., REGULATOR (10A)	1	-	-		QAPE,QNE,QNE2,QNE2/A,QNE9,QNE9/A,QPE2
3	31610-ZE3-W31ZB	BOX ASSY., CONTROL (ALERT) (10A)	1	-	-		
	*R8*	BRIGHT RED	1	-	-	2143683	QAPE,QNE
	31610-ZE3-W32ZA	BOX ASSY., CONTROL (10A)	1	-	-		
	*NH1*	BLACK	1	-	-	2801237	QNE9,QNE9/A
			1	-	-		QPE2
	31610-ZE3-W32ZB	*R8* BRIGHT RED	1	-	-	2143684	QAPE,QNE
			1	-	-		QNE2
	31610-ZE3-W41ZB	BOX ASSY., CONTROL (18A)	1	-	-		
	*R8*	BRIGHT RED	1	-	-	2801237	QNR2,QN18
	31610-ZE3-W33ZA	BOX ASSY., CONTROL (EXP-ALERT) (10A)	1	-	-		
	*NH1*	BLACK	1	-	-	2801238	QPE2
			1	-	-		QNE9
	31610-ZE3-W33ZB	*R8* BRIGHT RED	1	-	-	2801238	QNE2
			1	-	-		QNE2/A,QNE9/A
	31610-ZE3-W42ZA	BOX ASSY., CONTROL (EXP-ALERT) (18A)	1	-	-		
	*NH1*	BLACK	1	-	-		QL2,QNR2/A
			1	-	-	2801238	QNR2
	31610-ZE3-W42ZB	*R8* BRIGHT RED	1	-	-	2801238	QNR2,QN18
			1	-	-		QNR2/A
	31610-ZE3-W33ZD	BOX ASSY., CONTROL (EXP-ALERT) (10A)	1	-	-		
	*R280*	POWER RED	1	-	-	3664907	QNE2/A,QNE9/A



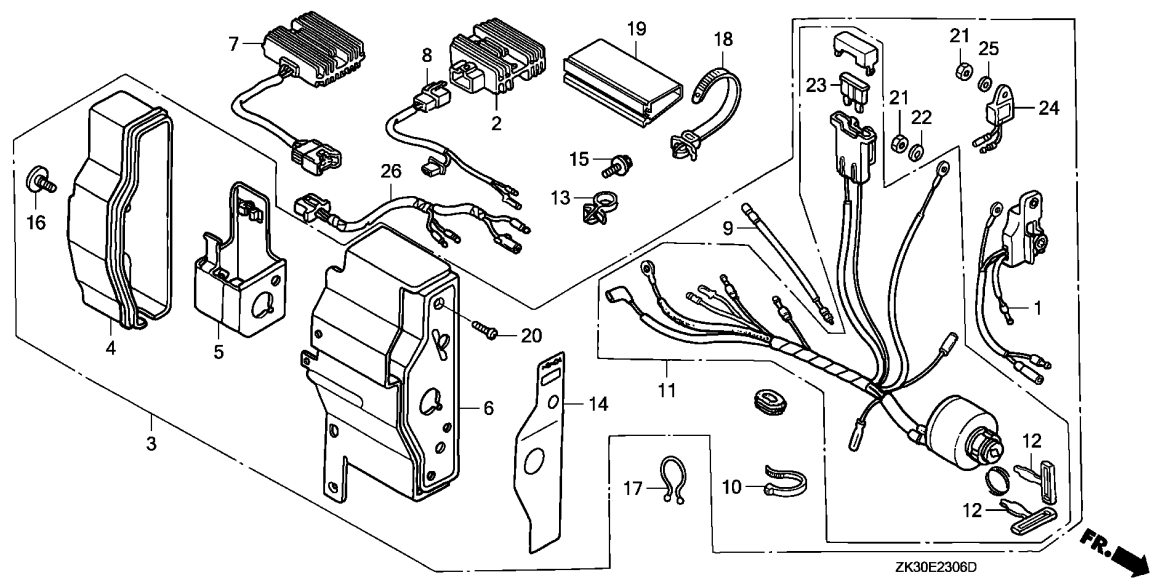

Ref. No.	Part No.	Description	Reqd. QTY			Serial No.	Parts catalogue code
			GX	(1)	(2)		
(3)	31610-ZE3-W42ZD	BOX ASSY., CONTROL (EXP-ALERT) (18A)					
		*R280*.....POWER RED	1	-	-	3663868	----- QNR2/A
4	31612-ZE2-003	CASE, CONTROL	1	-	-	-----	----- QAPE,QL2,QNE,QNE2,QNE2/A,QNE9,QNE9/A,QNR2,QNR2/A,QN18,QPE2
5	31614-ZE2-003	BRACKET, CASE MOUNTING	1	-	-	-----	----- QAPE,QL2,QNE,QNE2,QNE2/A,QNE9,QNE9/A,QNR2,QNR2/A,QN18,QPE2
6	31615-ZE3-003ZA	PANEL COMP., CONTROL					
		*NH1*.....BLACK	1	-	-	-----	----- QAPE,QNE,QNE2,QNE2/A,QNE9,QNE9/A,QNR2,QNR2/A,QPE2
	31615-ZE3-003ZB	*R8*.....BRIGHT RED	1	-	-	-----	----- QAPE,QNE,QNE2,QNE2/A,QNE9,QNE9/A,QNR2,QNR2/A,QN18
			1	-	-	3662149	----- QNE2/A,QNE9/A,QNR2/A
	31615-ZE3-003ZE	*R280*.....POWER RED	1	-	-	3662150	----- QNE2/A,QNE9/A,QNR2/A
7	31620-ZG5-003	RECTIFIER ASSY., REGULATOR (20A)	1	-	-	-----	----- QNR2,QN18
	31620-ZG5-013	.....	1	-	-	-----	----- QNR2/A
8	32110-ZE2-860	HARNESS ASSY., SUB WIRE	1	-	-	-----	----- QAPE,QNE,QNE2,QNE2/A,QNE9,QNE9/A,QPE2
9	32197-ZE1-003	SUB HARNESS	1	-	-	-----	----- QL2,QNE2,QNE2/A,QNE9,QNE9/A,QNR2,QNR2/A,QN18,QPE2
10	32902-892-003	BAND	1	-	-	-----	----- QAPE,QL2,QNE,QNE2,QNE2/A,QNE9,QNE9/A,QNR2,QNR2/A,QN18,QPE2
11	35100-ZE2-862	SWITCH ASSY., COMBINATION (10A-CHARGE)	1	-	-	-----	----- QAPE,QNE,QNE2,QNE2/A,QNE9,QNE9/A,QPE2
	35100-ZE2-W01	SWITCH ASSY., COMBINATION (18A-CHARGE)	1	-	-	-----	----- QL2,QNR2,QNR2/A,QN18
12	35111-880-003	KEY COMP.	2	-	-	-----	----- QAPE,QL2,QNE,QNE2,QNE9,QNR2
			2	-	-	3792398	----- QNE2/A,QNE9/A,QNR2/A
			2	-	-	3838382	----- QN18,QPE2
	35111-880-013	.....	2	-	-	3792399	----- QNE2/A,QNE9/A,QNR2/A
			2	-	-	3838383	----- QN18,QPE2
13	36103-ZE1-000	HOLDER, STOP SWITCH CORD	1	-	-	-----	----- QAPE,QL2,QNE,QNE2,QNE2/A,QNE9,QNE9/A,QNR2,QNR2/A,QN18,QPE2

Ref. No.	Part No.	Description	Reqd. QTY			Serial No.	Parts catalogue code
			(1)	(2)	(3)		
14	87529-ZE2-870	MARK, CONTROL BOX (EXTERNAL-ALERT)(REGULATOR)	1	-	-	2143683	QAPE,QNE
	87529-ZE2-860	MARK, CONTROL BOX (EXTERNAL-REGULATOR)	1	-	-		QL2,QNE2,QNE9,QNR2,QN18,QPE2
			1	-	-	2143684	QAPE,QNE
			1	-	-	3724889	QNE2/A,QNE9/A,QNR2/A
	87529-ZE2-861	.....	1	-	-	3724890	QNE2/A,QNE9/A,QNR2/A
15	90013-883-000	BOLT, FLANGE, 6X12(CT200) ...	2	-	-		QAPE,QL2,QNE,QNR2,QNR2/A,QN18
			2	-	-	2644833	QNE2,QNE9,QPE2
16	90380-MA6-010	SCREW, SPECIAL, 6X12 .....	1	-	-		QAPE,QL2,QNE,QNE2,QNE2/A,QNE9,QNE9/A,QNR2,QNR2/A,QN18,QPE2
17	90630-751-000	CLIP, PURSE LOCK .....	1	-	-		QAPE,QL2,QNE,QNE2,QNE2/A,QNE9,QNE9/A,QNR2,QNR2/A,QN18,QPE2
18	90672-SAO-003	STRAP, CABLE, 118MM(BLACK) ..	1	-	-		QAPE,QL2,QNE,QNE2,QNE2/A,QNE9,QNE9/A,QNR2,QNR2/A,QN18,QPE2
19	91406-ZE2-003	TUBE, FASTENER, 30MM .....	1	-	-		QAPE,QL2,QNE,QNE2,QNE2/A,QNE9,QNE9/A,QNR2,QNR2/A,QN18,QPE2
20	93500-04012-OH	SCREW, PAN, 4X12 .....	1	-	-		QAPE,QL2,QNE,QNE2,QNE2/A,QNE9,QNE9/A,QNR2,QNR2/A,QN18,QPE2
21	94001-04390-0S	NUT, HEX., 4MM .....	1	-	-	2801237	QNE2,QNR2,QN18,QPE2
			2	-	-		QL2,QNE2/A,QNE9,QNE9/A,QNR2/A
			2	-	-	2143683	QAPE,QNE
			1	-	-	2143684	QAPE,QNE
			2	-	-	2801238	QNE2,QNR2,QN18,QPE2
22	94111-04800	WASHER, SPRING, 4MM .....	1	-	-		QAPE,QL2,QNE,QNE2,QNE2/A,QNE9,QNE9/A,QNR2,QNR2/A,QN18,QPE2
23	98200-31500	FUSE, BLADE (15A) .....	1	-	-		QAPE,QNE,QNE2,QNE2/A,QNE9,QNE9/A,QPE2
	98200-32500	FUSE, BLADE (25A) .....	1	-	-		QL2,QNR2,QNR2/A,QN18
24	34150-ZH7-003	ALERT UNIT, OIL .....	1	-	-		QL2,QNE2/A,QNE9,QNE9/A,QNR2/A
			1	-	-	2801238	QNE2,QNR2,QN18,QPE2
			1	-	-	2143683	QAPE,QNE
25	94101-04800	WASHER, PLAIN, 4MM .....	1	-	-		QL2,QNE2/A,QNE9,QNE9/A,QNR2/A
			1	-	-	2801238	QNE2,QNR2,QN18,QPE2
			1	-	-	2143683	QAPE,QNE
26	32110-ZE2-W00	HARNESS ASSY., SUB WIRE .....	1	-	-		QNR2,QNR2/A,QN18



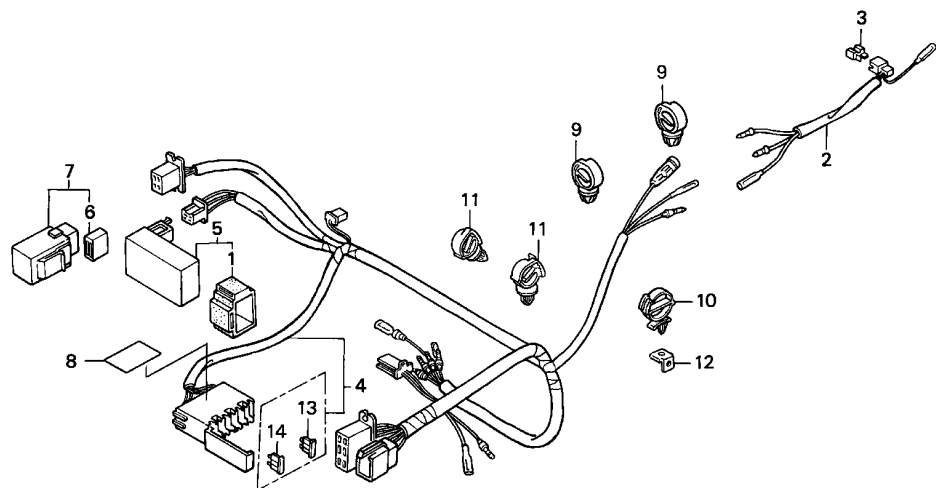

ZK30-E2320A

Ref. No.	L.O.N.	(Relative ref. Number) Description	F.R.T.
2	6211C6	DIODE, SOLENOID .....	0.1
4	6111D3	HARNESS, SUB WIRE .....	0.4
5	6211C7	CONTROL UNIT, SOLENOID .....	0.2
7	6151F6	TIMER UNIT .....	0.2
13		(14)	
	8121A7	FUSE, BLADE .....	0.1

.NOTE: Same time for two units

Ref. No.	Part No.	Description	Reqd. QTY			Serial No.	Parts catalogue code
			GX	340K1			
			(1)	(2)	(3)		
1	30401-HA0-000	CUSHION, C.D.I. UNIT .....	1	-	-	-----	EDS5
2	31700-ZB7-003	DIODE ASSY., SOLENOID .....	1	-	-	-----	EDS5
3	31700-166-008	RECTIFIER COMP., SILICON .....	1	-	-	-----	EDS5
4	32100-ZB7-A00	HARNESS ASSY., SUB WIRE .....	1	-	-	2639737	EDS5
	32100-ZB7-A01	.....	1	-	-	2639738	EDS5
5	36150-ZB7-A01	CONTROL UNIT, SOLENOID .....	1	-	-	-----	EDS5
6	38306-KK4-000	SUSPENSION, WINKER RELAY (MITSUBA)	1	-	-	-----	EDS5
7	39500-ZB7-003	TIMER UNIT .....	1	-	-	-----	EDS5
8	87117-ZB7-A30	LABEL, FUSE .....	1	-	-	-----	EDS5
9	90683-SA0-003	CLIP, WIRE HARNESS, 25MM .....	2	-	-	-----	EDS5
10	90690-SA0-003	STRAP, WIRE HARNESS, 25MM (BLACK)	1	-	-	-----	EDS5
11	90691-ZB7-003	CLIP, HARNESS .....	2	-	-	-----	EDS5
12	90700-ZB7-000	BASE, CORD CLIP .....	1	-	-	-----	EDS5
13	98200-30500	FUSE, BLADE (5A) .....	1	-	-	-----	EDS5
14	98200-31000	FUSE, BLADE (10A) .....	1	-	-	-----	EDS5



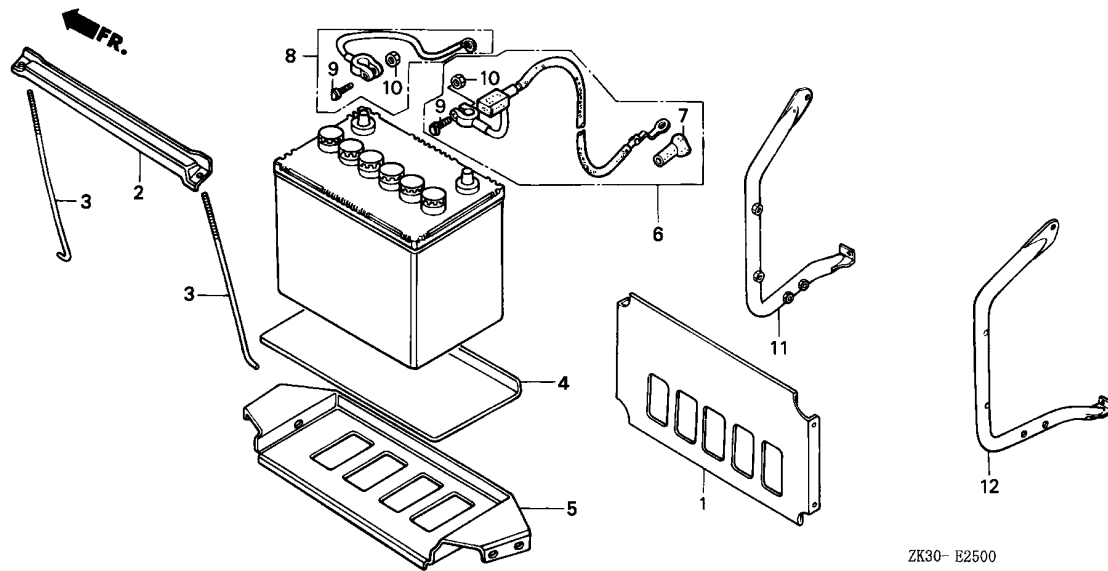

Ref. No.	L.O.N.	(Relative ref. Number) Description	F.R.T.
5	4101T4	TRAY, BATTERY .....	0.2
6	610115	CABLE, BATTERY STARTER .....	0.2
8	6101A8	CABLE, BATTERY EARTH .....	0.2
11	6101A9	GUARD, BATTERY :FRONT .....	0.1
12	6101B0	GUARD, BATTERY :REAR .....	0.1

Ref. No.	Part No.	Description	Reqd. QTY			Serial No.	Parts catalogue code
			GX	340K1			
			(1)	(2)	(3)		
1	31511-ZB4-000	PLATE, BATTERY GUARD .....	1	-	-	ES4,ES4/A,VS5,VS6,VS7	
2	31512-880-810	PLATE, BATTERY SETTING .....	1	-	-	ES4,ES4/A,VS5,VS6,VS7	
3	31513-634-000	BOLT, BATTERY SETTING, 220MM .....	2	-	-	ES4,ES4/A,VS5,VS6,VS7	
4	31521-880-000	PLATE, BATTERY .....	1	-	-	ES4,ES4/A,VS5,VS6,VS7	
5	31550-899-000	BASE, BATTERY TRAY .....	1	-	-	ES4,ES4/A,VS5,VS6,VS7	
6	32410-ZB4-620	CABLE ASSY., STARTING .....	1	-	-	ES4,ES4/A,VS5,VS6,VS7	
7	32411-253-000	COVER, STARTER MOTOR TERMINAL .....	1	-	-	ES4,ES4/A,VS5,VS6,VS7	
8	32430-ZB4-620	CABLE ASSY., EARTH .....	1	-	-	ES4,ES4/A,VS5,VS6,VS7	
9	32601-SK7-900	BOLT, BATTERY TERMINAL .....	2	-	-	ES4,ES4/A,VS5,VS6,VS7	
10	32602-SK7-900	NUT, BATTERY TERMINAL .....	2	-	-	ES4,ES4/A,VS5,VS6,VS7	
11	50365-ZD1-E30ZA	GUARD, FR. BATTERY					
		*NH105*...MAT BLACK (#15-#20)	1	-	-	ES4,ES4/A	
	50365-ZD1-E30ZB	*NH1*...BLACK	1	-	-	ES4,ES4/A	
12	50375-ZD1-E30ZA	GUARD, RR. BATTERY					
		*NH105*...MAT BLACK (#15-#20)	1	-	-	ES4,ES4/A	
	50375-ZD1-E30ZB	*NH1*...BLACK	1	-	-	ES4,ES4/A	

E-25-1

BATTERY(2)

2-H16

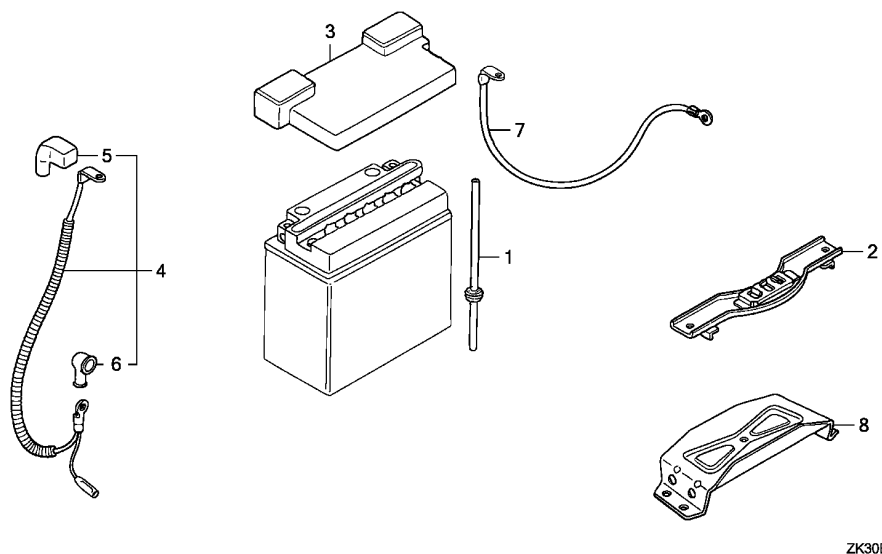

Ref. No.	L.O.N.	(Relative ref. Number) Description	F.R.T.
2	6101B5	PLATE, BATTERY SETTING .....	0.1
4	6101B1	CABLE, BATTERY STARTER(A) ....	0.1
7	6101B2	CABLE, BATTERY EARTH(A) .....	0.1

Ref. No.	Part No.	Description	Reqd. QTY			Serial No.	Parts catalogue code
			GX	340K1			
			(1)	(2)	(3)		
1	31507-ZB7-000	TUBE, BATTERY BREATHER .....	1	-	-	-----	EDS5
2	31512-ZB7-000	PLATE, BATTERY SETTING .....	1	-	-	-----	EDS5
3	31513-ZB7-000	COVER, BATTERY .....	1	-	-	-----	EDS5
4	32410-ZB7-A00	CABLE ASSY., STARTING .....	1	-	-	-----	EDS5
5	32412-471-000	COVER, BATTERY TERMINAL .....	1	-	-	-----	EDS5
6	32416-460-000	COVER B, MAGNETIC SWITCH .....	1	-	-	-----	EDS5
7	32430-ZB7-000	CABLE ASSY., EARTH .....	1	-	-	-----	EDS5
8	50319-ZB7-000	BASE, BATTERY .....	1	-	-	-----	EDS5

2

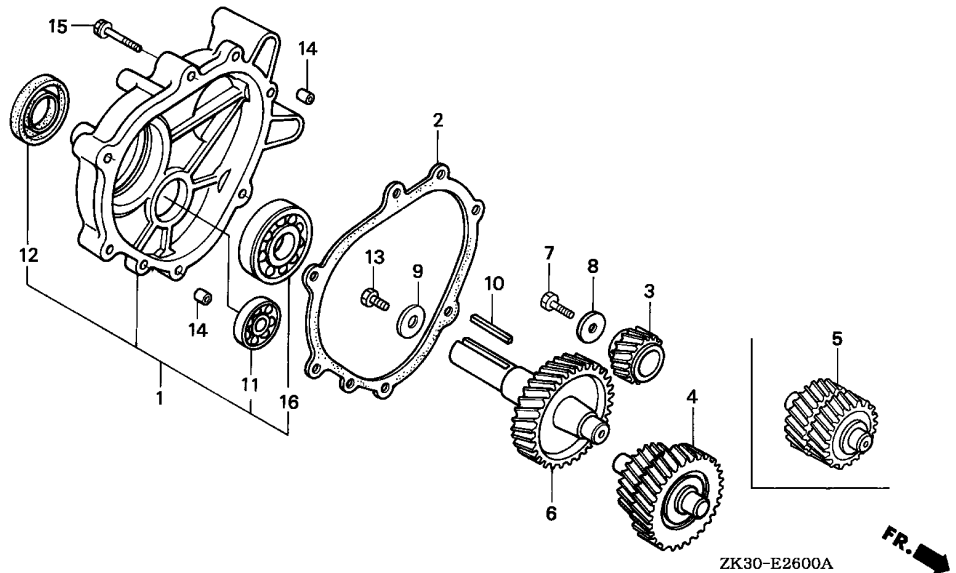

Ref. No.	L.O.N.	(Relative ref. Number) Description	F.R.T.
1		(2) COVER, REDUCTION GEAR CASE ...	0.2
3		2141L2 GEAR, PRIMARY DRIVE .....	0.2
4		(5) COUNTERSHAFT .....	0.3
6		2091A2 SHAFT, POWER TAKE OFF .....	0.3
11		2141H4 BEARING, COUNTERSHAFT :REAR ..	0.3
12		2101U4 OIL SEAL, POWER TAKE OFF SHAFT	0.3
16		2141F2 BEARING, POWER TAKE OFF SHAFT :REAR .....	0.3

Ref. No.	Part No.	Description	Reqd. QTY			Serial No.	Parts catalogue code
			(1)	(2)	(3)		
1	11500-ZE3-611	COVER ASSY., GEAR CASE .....	1	1	-	LH,LH/A,LHB1,LHB3,LHB3/A,LHB5,LHC,LHE,LHE/A,LHQ4,LHQ4/A,LHW,LJ LJ/A,LJG,LJG/A,LJS,LJS/A,LJS1,LKE,LKE/A,LP,LSX,LWD,LWD1/A,LX LX/A,LXE,LXE/A,LXE2,LXE2/A,LXE4,LXE4/A,LXE6,LXE8,LXE8/A,LXQ4 LXQ4/A,LXU,LXU/A,LXZ,LX2,LX2/A,LX26,LX26/A,L1,L1/A,ZK1,ZK1/A	
	11500-ZE3-620	.....	1	-	-	BJ	
	11500-ZK3-800	.....	1	-	-	LT,LT/A	
2	11521-ZE2-610	PACKING, CHAIN CASE COVER ...	1	(1)	-	2178372 BJ,LJ,LP,LXZ,L1	
	11521-ZE2-800	.....	1	1	-	LH,LH/A,LHB1,LHB3,LHB3/A,LHB5,LHC,LHE,LHE/A,LHQ4,LHQ4/A,LHW,LJ/A LJG,LJG/A,LJS,LJS/A,LJS1,LKE,LKE/A,LSX,LT,LT/A,LWD,LWD1,LWD1/A,LX LX/A,LXE,LXE/A,LXE2,LXE2/A,LXE4,LXE4/A,LXE6,LXE8,LXE8/A,LXQ4 LXQ4/A,LXU,LXU/A,LX2,LX2/A,LX26,LX26/A,L1/A,ZK1,ZK1/A	
3	22103-ZE3-610	GEAR, PRIMARY DRIVE (22T) ...	1	1	-	2178373 BJ,LJ,LP,LXZ,L1	
	22103-ZE3-W00	GEAR, PRIMARY DRIVE (BANKA) .	1	-	-	BJ,LH,LH/A,LHB1,LHB3,LHB3/A,LHB5,LHC,LHE,LHE/A,LHQ4,LHQ4/A,LHW,LJ LJ/A,LJG,LJG/A,LJS,LJS/A,LJS1,LKE,LKE/A,LSX,LT,LT/A,LWD,LWD1 LWD1/A,LX,LX/A,LXE,LXE/A,LXE2,LXE2/A,LXE4,LXE4/A,LXE6,LXE8,LXE8/A LXQ4,LXQ4/A,LXU,LXU/A,LXZ,LX2,LX2/A,LX26,LX26/A,L1,L1/A,ZK1,ZK1/A	
4	23220-ZE3-610	COUNTERSHAFT COMP. ....	1	1	-	LP	
5	23222-ZE3-W00	GEAR, COUNTER (BANKA) .....	1	-	-	BJ,LH,LH/A,LHB1,LHB3,LHB3/A,LHB5,LHC,LHE,LHE/A,LHQ4,LHQ4/A,LHW,LJ LJ/A,LJG,LJG/A,LJS,LJS/A,LJS1,LKE,LKE/A,LSX,LT,LT/A,LWD,LWD1 LWD1/A,LX,LX/A,LXE,LXE/A,LXE2,LXE2/A,LXE4,LXE4/A,LXE6,LXE8,LXE8/A LXQ4,LXQ4/A,LXU,LXU/A,LXZ,LX2,LX2/A,LX26,LX26/A,L1,L1/A,ZK1,ZK1/A	
6	23710-ZE3-610	SHAFT, P.T.O. (33T) .....	1	1	-	LP	
	23710-ZE3-620	.....	1	-	-	LH,LH/A,LHB1,LHB3,LHB3/A,LHB5,LHC,LHE,LHE/A,LHQ4,LHQ4/A,LHW,LJ LJ/A,LJG,LJG/A,LJS,LJS/A,LJS1,LKE,LKE/A,LP,LSX,LWD,LWD1,LWD1/A,LX LX/A,LXE,LXE/A,LXE2,LXE2/A,LXE4,LXE4/A,LXE6,LXE8,LXE8/A,LXQ4 LXQ4/A,LXU,LXU/A,LXZ,LX2,LX2/A,LX26,LX26/A,L1,L1/A,ZK1,ZK1/A	
	23710-ZK3-800	.....	1	-	-	BJ LT,LT/A	



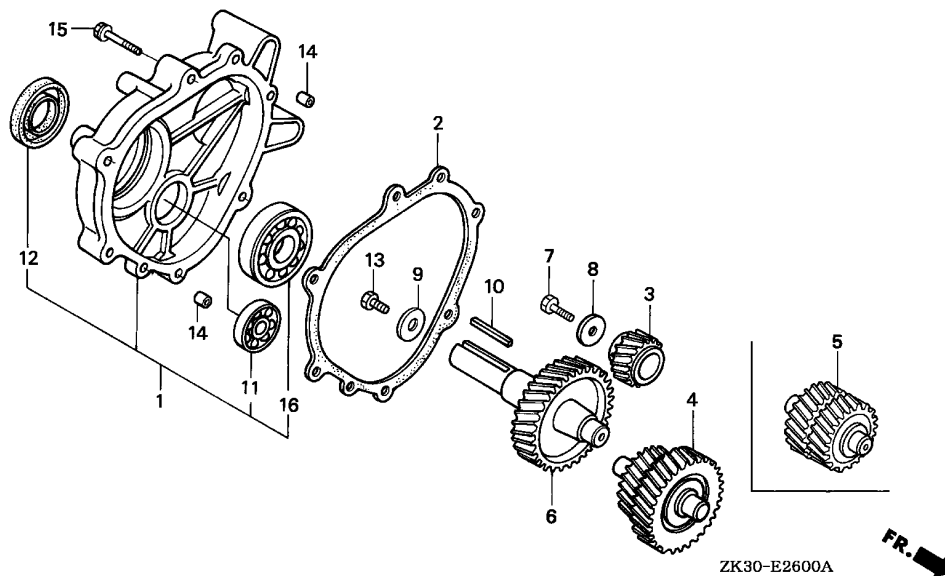

Ref. No.	Part No.	Description	Reqd. QTY			Serial No.	Parts catalogue code
			(1)	(2)	(3)		
7	90107-959-003	BOLT, HEX., 8X25	1	1	-	BJ, LH, LH/A, LHB1, LHB3, LHB3/A, LHB5, LHC, LHE, LHE/A, LHQ4, LHQ4/A, LHW, LJ, LJ/A, LJG, LJG/A, LJS, LJS/A, LJS1, LKE, LKE/A, LP, LSX, LT, LT/A, LWD, LWD1, LWD1/A, LX, LX/A, LXE, LXE/A, LXE2, LXE2/A, LXE4, LXE4/A, LXE6, LXE8, LXE8/A, LXQ4, LXQ4/A, LXU, LXU/A, LXZ, LX2, LX2/A, LX26, LX26/A, L1, L1/A, ZK1, ZK1/A	
8	90473-ZE3-010	WASHER, 8MM	1	1	-	BJ, LH, LH/A, LHB1, LHB3, LHB3/A, LHB5, LHC, LHE, LHE/A, LHQ4, LHQ4/A, LHW, LJ, LJ/A, LJG, LJG/A, LJS, LJS/A, LJS1, LKE, LKE/A, LP, LSX, LT, LT/A, LWD, LWD1, LWD1/A, LX, LX/A, LXE, LXE/A, LXE2, LXE2/A, LXE4, LXE4/A, LXE6, LXE8, LXE8/A, LXQ4, LXQ4/A, LXU, LXU/A, LXZ, LX2, LX2/A, LX26, LX26/A, L1, L1/A, ZK1, ZK1/A	
9	90471-ZE3-000	WASHER, 10.5X40X4	1	-	-	BJ	
	90534-706-010	WASHER, LOCK, 8MM	1	(1)	-	LJ, LJ/A, LJG, LJG/A, LJS, LJS/A, LJS1, LWD, L1, L1/A	
10	90741-805-000	KEY, 7X7X33	1	(1)	-	BJ, LH, LH/A, LHB1, LHB3, LHB3/A, LHB5, LHC, LHE, LHE/A, LHQ4, LHQ4/A, LHW, LJ, LJ/A, LJG, LJG/A, LJS, LJS/A, LJS1, LKE, LKE/A, LP, LSX, LWD, LX, LX/A, LXE, LXE/A, LXE2, LXE2/A, LXE4, LXE4/A, LXE6, LXE8, LXE8/A, LXQ4, LXQ4/A, LXU, LXU/A, LXZ, LX2, LX2/A, LX26, LX26/A, L1, L1/A	
	90741-889-810	KEY, 7X7X33(YELLOW)	(1)	-	-	LWD1, LWD1/A	
	90745-ZK2-800	KEY, 6.3X6.3X33	(1)	(1)	-	BJ, LH, LH/A, LHB1, LHB3, LHB3/A, LHB5, LHC, LHE, LHE/A, LHQ4, LHQ4/A, LHW, LJ, LJ/A, LJG, LJG/A, LJS, LJS/A, LJS1, LKE, LKE/A, LP, LSX, LWD, LX, LX/A, LXE, LXE/A, LXE2, LXE2/A, LXE4, LXE4/A, LXE6, LXE8, LXE8/A, LXQ4, LXQ4/A, LXU, LXU/A, LXZ, LX2, LX2/A, LX26, LX26/A, L1, L1/A	
	90741-ZE3-L60	KEY, 7X7X40	1	-	-	LT, LT/A	
			1	-	-	ZK1, ZK1/A	
11	91009-KJ1-003	BEARING, RADIAL BALL, 6202 (NTN)	1	1	-	BJ, LH, LH/A, LHB1, LHB3, LHB3/A, LHB5, LHC, LHE, LHE/A, LHQ4, LHQ4/A, LHW, LJ, LJ/A, LJG, LJG/A, LJS, LJS/A, LJS1, LKE, LKE/A, LP, LSX, LT, LT/A, LWD, LWD1, LWD1/A, LX, LX/A, LXE, LXE/A, LXE2, LXE2/A, LXE4, LXE4/A, LXE6, LXE8, LXE8/A, LXQ4, LXQ4/A, LXU, LXU/A, LXZ, LX2, LX2/A, LX26, LX26/A, L1, L1/A, ZK1, ZK1/A	

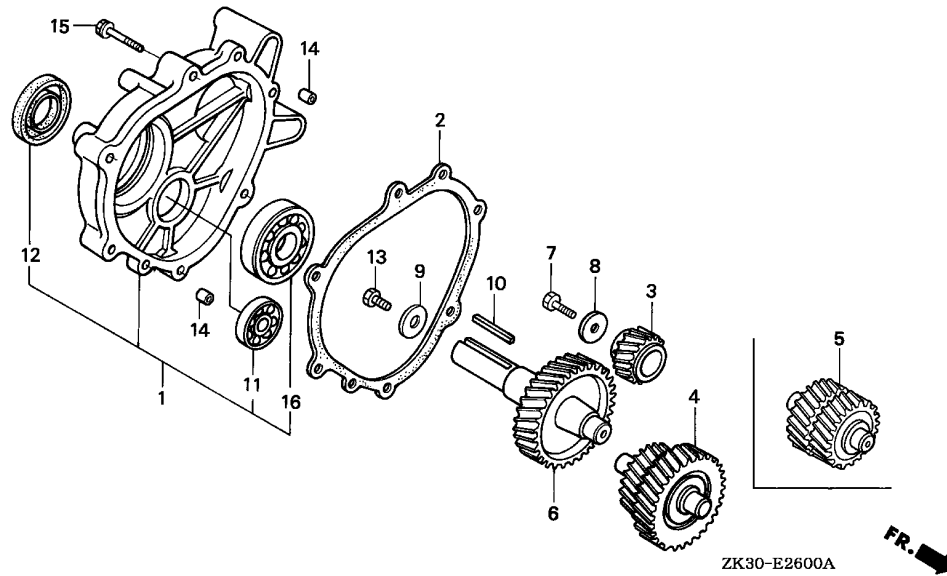

Ref. No.	Part No.	Description	Reqd. QTY			Serial No.	Parts catalogue code
			(1)	(2)	(3)		
12	91201-890-003	OIL SEAL, 30X46X8 .....	1	1	-	-----	LH,LH/A,LHB1,LHB3,LHB3/A,LHB5,LHC,LHE,LHE/A,LHQ4,LHQ4/A,LHW,LJ LJ/A,LJG,LJG/A,LJS,LJS/A,LJS1,LKE,LKE/A,LP,LSX,LT,LT/A,LWD,LWD1 LWD1/A,LX,LX/A,LXE,LXE/A,LXE2,LXE2/A,LXE4,LXE4/A,LXE6,LXE8,LXE8/A LXQ4,LXQ4/A,LXU,LXU/A,LXZ,LX2,LX2/A,LX26,LX26/A,L1,L1/A,ZK1,ZK1/A
	91201-ZE3-004	OIL SEAL, 35X52X8 .....	1	-	-	-----	BJ
13	92000-08025-0A	BOLT, HEX., 8X25 .....	-	(1)	-	-----	L1
	92000-10025-0A	BOLT, HEX., 10X25 .....	1	-	-	-----	L1/A,S1/A
	92101-08025-0A	BOLT, HEX., 8X25 .....	1	-	-	-----	BJ
			-	(1)	-	4077287	LJ,LJ/A,LJG,LJG/A,LJS,LJS/A,LJS1,LWD L1/A,S1/A
14	94301-08140	DOWEL PIN, 8X14 .....	2	2	-	-----	BJ,LH,LH/A,LHB1,LHB3,LHB3/A,LHB5,LHC,LHE,LHE/A,LHQ4,LHQ4/A,LHW,LJ LJ/A,LJG,LJG/A,LJS,LJS/A,LJS1,LKE,LKE/A,LP,LSX,LT,LT/A,LWD,LWD1 LWD1/A,LX,LX/A,LXE,LXE/A,LXE2,LXE2/A,LXE4,LXE4/A,LXE6,LXE8,LXE8/A LXQ4,LXQ4/A,LXU,LXU/A,LXZ,LX2,LX2/A,LX26,LX26/A,L1,L1/A,ZK1,ZK1/A
15	95701-08040-00	BOLT, FLANGE, 8X40 .....	6	6	-	-----	BJ,LH,LH/A,LHB1,LHB3,LHB3/A,LHB5,LHC,LHE,LHE/A,LHQ4,LHQ4/A,LHW,LJ LJ/A,LJG,LJG/A,LJS,LJS/A,LJS1,LKE,LKE/A,LP,LSX,LT,LT/A,LWD,LWD1 LWD1/A,LX,LX/A,LXE,LXE/A,LXE2,LXE2/A,LXE4,LXE4/A,LXE6,LXE8,LXE8/A LXQ4,LXQ4/A,LXU,LXU/A,LXZ,LX2,LX2/A,LX26,LX26/A,L1,L1/A,ZK1,ZK1/A
16	96100-62060-00	BEARING, RADIAL BALL, 6206 ..	1	1	-	-----	LH,LH/A,LHB1,LHB3,LHB3/A,LHB5,LHC,LHE,LHE/A,LHQ4,LHQ4/A,LHW,LJ LJ/A,LJG,LJG/A,LJS,LJS/A,LJS1,LKE,LKE/A,LP,LSX,LT,LT/A,LWD,LWD1 LWD1/A,LX,LX/A,LXE,LXE/A,LXE2,LXE2/A,LXE4,LXE4/A,LXE6,LXE8,LXE8/A LXQ4,LXQ4/A,LXU,LXU/A,LXZ,LX2,LX2/A,LX26,LX26/A,L1,L1/A,ZK1,ZK1/A
	96100-62070-00	BEARING, RADIAL BALL, 6207 ..	1	-	-	-----	BJ



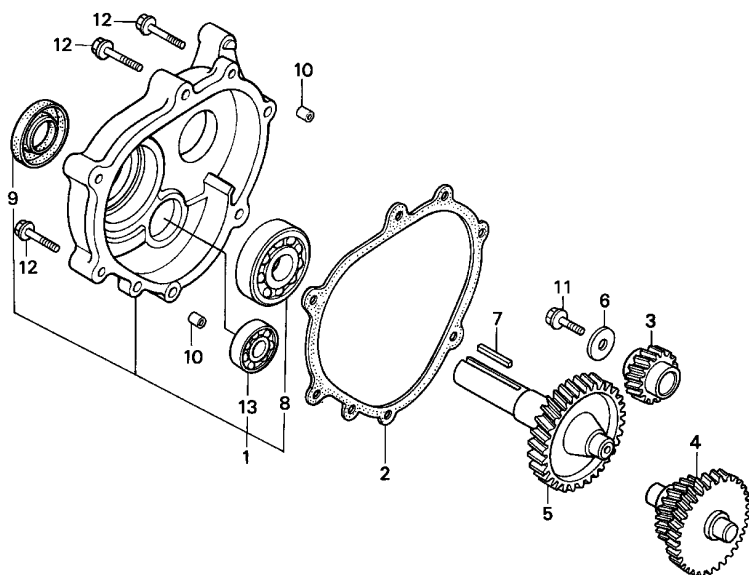

Ref. No.	L.O.N.	(Relative ref. Number) Description	F.R.T.
1	(2)	COVER, REDUCTION GEAR CASE ...	0.2
3	2141L2	GEAR, PRIMARY DRIVE .....	0.2
4	2091A2	COUNTERSHAFT .....	0.3
5	2141H4	SHAFT, POWER TAKE OFF .....	0.3
8	2141L0	BEARING, POWER TAKE OFF SHAFT :REAR .....	0.3
9	2141L5	OIL SEAL, POWER TAKE OFF SHAFT :REAR .....	0.3
13	2101U4	BEARING, COUNTERSHAFT :REAR ..	0.3

Ref. No.	Part No.	Description	Reqd. QTY			Serial No.	Parts catalogue code
			(1)	(2)	(3)		
1	11500-ZE3-640	COVER ASSY., GEAR CASE .....	1	-	-	HA,HAQ,HA2,HA2/A,HH,HX,HX2,HX26,HX26/A	
2	11521-ZE2-800	PACKING, CHAIN CASE COVER ...	1	-	-	HA,HAQ,HA2,HA2/A,HH,HX,HX2,HX26,HX26/A	
3	22103-ZE3-640	GEAR, PRIMARY DRIVE (12T) ...	1	-	-	HA,HAQ,HA2,HA2/A,HH,HX,HX2,HX26,HX26/A	
4	23220-ZE3-640	COUNTERSHAFT COMP. ....	1	-	-	HA,HAQ,HA2,HA2/A,HH,HX,HX2,HX26,HX26/A	
5	23710-ZE3-640	SHAFT, P.T.O. (34T) .....	1	-	-	HA,HAQ,HA2,HA2/A,HH,HX,HX2,HX26,HX26/A	
6	90473-842-000	WASHER, 8MM .....	1	-	-	HA,HAQ,HA2,HA2/A,HH,HX,HX2,HX26,HX26/A	
7	90745-ZK2-800	KEY, 6.3X6.3X33 .....	1	-	-	HA,HAQ,HA2,HA2/A,HH,HX,HX2,HX26,HX26/A	
8	91006-MT3-003	BEARING, RADIAL BALL, 6206 (NTN)	1	-	-	HA,HAQ,HA2,HA2/A,HH,HX,HX2,HX26,HX26/A	
9	91201-890-003	OIL SEAL, 30X46X8 .....	1	-	-	HA,HAQ,HA2,HA2/A,HH,HX,HX2,HX26,HX26/A	
10	94301-08140	DOWEL PIN, 8X14 .....	2	-	-	HA,HAQ,HA2,HA2/A,HH,HX,HX2,HX26,HX26/A	
11	95701-08025-00	BOLT, FLANGE, 8X25 .....	1	-	-	HA,HAQ,HA2,HA2/A,HX2,HX26,HX26/A	
	95900-08025-00	.....	1	-	-	HH,HX	
12	95701-08040-00	BOLT, FLANGE, 8X40 .....	6	-	-	HA,HAQ,HA2,HA2/A,HH,HX,HX2,HX26,HX26/A	
13	96100-63020-00	BEARING, RADIAL BALL, 6302 ..	1	-	-	HA,HAQ,HA2,HA2/A,HH,HX,HX2,HX26,HX26/A	

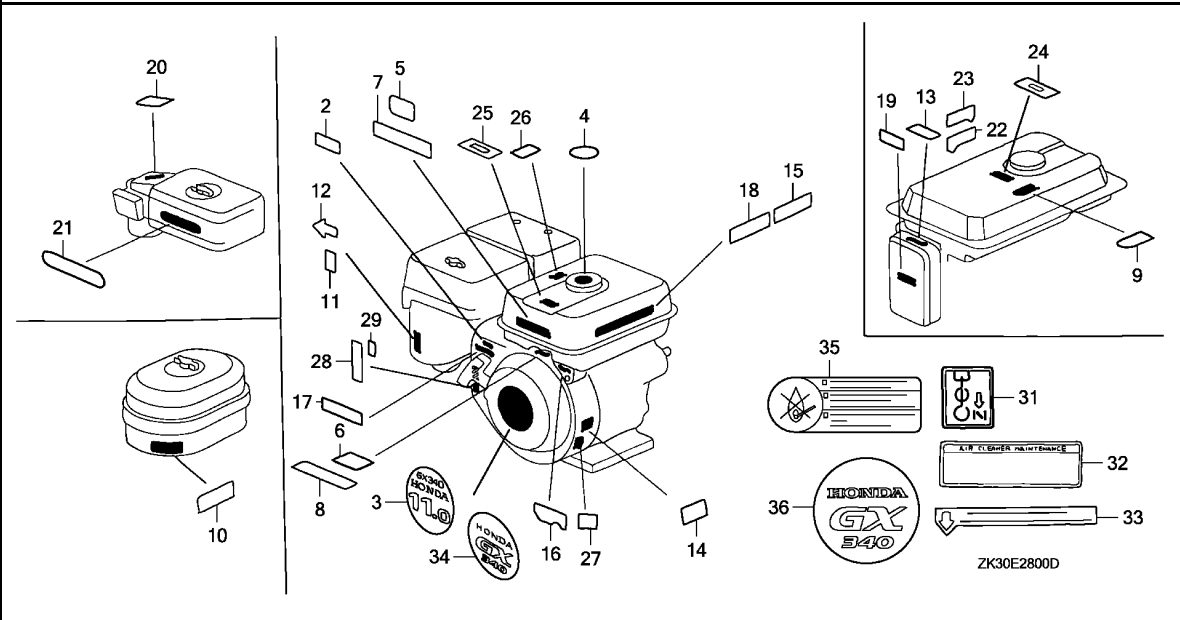

Ref. No.	L.O.N.	(Relative ref. Number)	Description	F.R.T.
NO INFORMATION .....				

Ref. No.	Part No.	Description	Reqd. QTY			Serial No.	Parts catalogue code
			GX	340K1	(3)		
2	87124-ZV3-010	MARK, EMERGENCY SWITCH INDICATION	-	-	1		
3	87521-ZE3-W10	EMBLEM (GX340 HONDA 11.0HP) (ELECTRONIC IGNITION)	1	(1)	-	----- 2143835	ED6,ED7,EN,ES,ES1,ES3,ET,ETS,ETX,HH,HX,LH,LHC,LHE,LKE,LXE,LXZ,L1 PX,P1,QE,QH,QHC,QHE,QP,QT,QX,QXB,QXE,QXEB,Q1,SE,SH,SHE,SHEZ,SWX SX,SXB,SXE,SXEB,S1,VAA,VAE,VE,VH,VHE,VNG,VNG1,VNG2,VX,VXB,VXEB V1
	87521-ZE3-W01	EMBLEM (GX340 HONDA 11.0) (ELECTRONIC IGNITION)	1	(1)	-	2143836	3449599 ED6,ES1,ES3,LH,LHE,LXE,L1,PX,QE,QH,QHE,QP,QT,QX,QXB,QXE,SE,SH,SWX SX,SXB,SXE,SXEB,VX,VXB,VXEB
			1	-	-	----- 3449599	EDN5,EDS6,EDT6,ED8,ED9,EN6,ES4,HX26,LHB3,LHQ4,LT,LXE4,LXE8,LXQ4 LXU,LX26,PKT4,PKX4,PXE8,QAE6,QA26,QHB3,QHP1,QHQ4,QKA4,QME0,QME8 QMH,QNR6,QXC4,QXC6,QXE4,QXE6,QXE8,QXQ4,QXU,SHB3,SHQ4,SME0,SXE4 SXE8,SXQ4,SXU,VMT,VXE8,VXQ4,VXU,VXU1,VX16,VX8



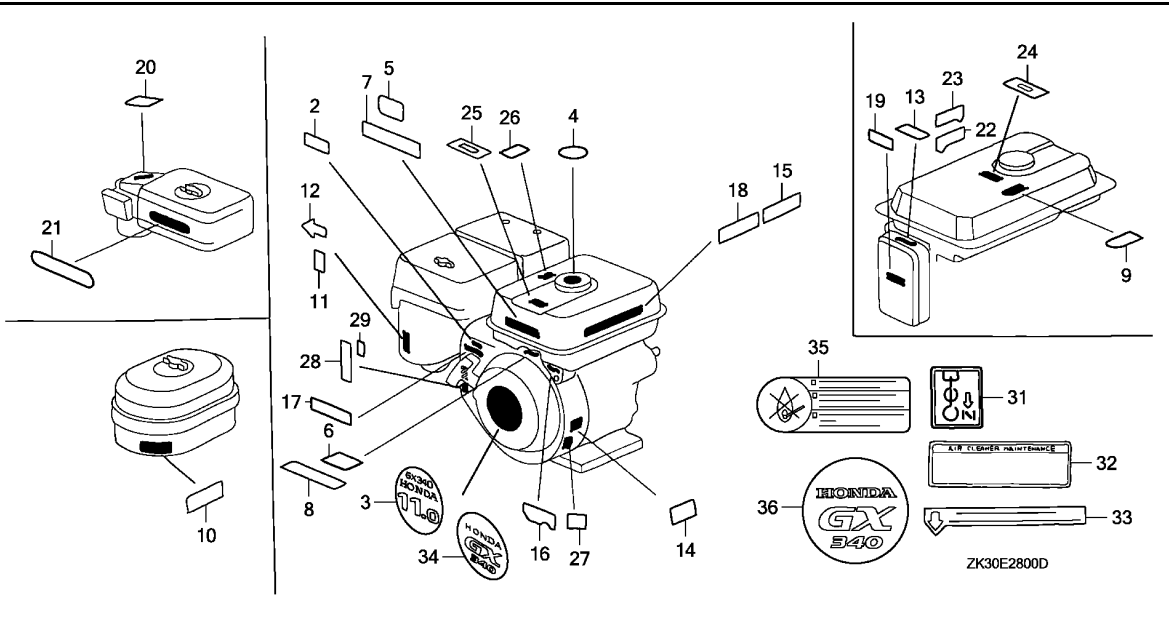

Ref. No.	Part No.	Description	Reqd. QTY			Serial No.	Parts catalogue code
			GX 340K1	(1)	(2)		
(3)	87521-ZE3-W02	EMBLEM (GX340 HONDA 11.0) ...	1	(1)	-	2143836 -----	ED7,EN,ES,ET,ETS,ETX,HH,HX,LHC,LXZ,P1,QHC,QXEB,Q1,SHE,SHEZ,S1,VAA VAAE,VE,VH,VHE,VNG,VNG1,VNG2,V1
			1	(1)	-	3449600 -----	EDN5,EDS6,EDT6,ED6,ED8,ED9,EN6,ES1,ES3,ES4,HX26,LH,LHB3,LHE,LHQ4 LT,LXE,LXE4,LXE8,LXQ4,LXU,LX26,L1,PKT4,PKX4,PX,PXE8,QAE6,QA26,QE QH,QHB3,QHE,QHP1,QHQ4,QKA4,QME0,QME8,QMH,QNR6,QP,QT,QX,QXB,QXC4 QXC6,QXE,QXE4,QXE6,QXE8,QXQ4,QXU,SE,SH,SHB3,SHQ4,SMEO,SWX,SX,SXB SXE,SXEB,SXE4,SXE8,SXQ4,SXU,VMT,VX,VXB,VXEB,VXE8,VXQ4,VXU,VXU1 VX16,VX8
			1	(1)	-	3663825 -----	EDN5/A,EDS6/A,EDT6/A,ED6/A,ED8/A,ED9/A,EMT/A,EN6/A,ES1/A,ES3/A ES4/A,HX26/A,LH/A,LHB3/A,LHB5,LHE/A,LHQ4/A,LT/A,LXE/A,LXE4/A LXE8/A,LXQ4/A,LXU/A,LX26/A,L1/A,PKT4/A,PKX4/A,PX/A,PXE8/A,P1/A QAE6/A,QA26/A,QE/A,QH/A,QHB3/A,QHB5,QHE/A,QHP1/A,QHQ4/A,QKA4/A QME0/A,QME8/A,QMH/A,QNR6/A,QP/A,QT/A,QX/A,QXB/A,QXB7/A,QXC4/A QXC6/A,QXE/A,QXE4/A,QXE6/A,QXE8/A,QXQ4/A,QXU/A,Q1/A,SE/A,SH/A SHB3/A,SHQ4/A,SMEO/A,SWX/A,SX/A,SXB/A,SXB7/A,SXE/A,SXEB/A,SXE4/A SXE8/A,SXQ4/A,SXU/A,S1/A,VMT/A,VX/A,VXB/A,VXB7/A,VXEB/A,VXE7/A VXE8/A,VXQ4/A,VXU/A,VXU1/A,VX16/A,VX8/A
			1	-	-	-----	EDN,EDS,EDS3,EMT,LHB1,LHW,LXE6,QNE6,QXB7,SHB1,SHT,SXB7,VD16,VEB6 VMX,VTE2,VXB2,VXB7,VXE4,VXE6,VXE7,VXG
			-	-	1		





Ref. No.	Part No.	Description	Reqd. QTY			Serial No.	Parts catalogue code
			(1)	(2)	(3)		
(3)	87521-ZE3-W03	EMBLEM (GX340 HONDA 11.0) ...	1	(1)	-	3663826 4072394	EDN5/A,ED8/A,ED9/A,EMT/A,ES1/A,ES3/A,ES4/A,LH/A,LHB3/A,LHB5,LHE/A,LT/A,LXE/A,L1/A,PX/A,P1/A,QH/A,QHB3/A,QHB5,QHP1/A,QMH/A,QP/A,QT/A,QX/A,QXE/A,Q1/A,SH/A,SA/A,SXE/A,S1/A,VMT/A,VX/A,VXE/A,VXU/A,VXU1/A
			1	-	-	-----	VSH7
			1	-	-	3663826	EDS6/A,EDT6/A,ED6/A,EN6/A,HX26/A,LHQ4/A,LXE4/A,LXE8/A,LXQ4/A,LXU/A,LX26/A,PKT4/A,PKX4/A,PXE8/A,QAE6/A,QA26/A,QE/A,QHE/A,QHQ4/A,QKA4/A,QMEO/A,QME8/A,QNR6/A,QXB/A,QXB7/A,QXC4/A,QXC6/A,QXE4/A,QXE6/A,QXE8/A,QXQ4/A,QXU/A,SE/A,SHB3/A,SHQ4/A,SMEO/A,SWX/A,SXB/A,SXB7/A,SXEB/A,SXE4/A,SXE8/A,SXQ4/A,SXU/A,VXB/A,VXB7/A,VXE7/A,VXE8/A,VXQ4/A,VX16/A,VX8/A
4	87522-ZE1-010	LABEL, FUEL WARNING .....	1	-	-	4072394	EDK,EDS4,VMQ,VXK
			1	-	-	-----	EN,ET
			1	-	-	2205608	ETS,ETX
	87522-ZE1-810	MARK, CAUTION .....	1	(1)	-	2302949	ED7,ED8,ED9,EN,ES,ES1,ET,HH,HX,LH,LHC,LHE,LKE,LP,LXE,LXZ,L1,PX,P1,QE,QH,QHC,QHE,QP,QX,QXB,QXE,QXEB,Q1,SE,SH,SHE,SHEZ,SWX,SP,SXB,SXE,SXEB,S1,VE,VH,VHE,VNG,VX,VXB,VXEB,VXU,VXU1,V1
			1	-	-	-----	LHB1,LHB3,LHB3/A,LHB5,LT,LT/A,QHB3,QHB3/A,QHB5,QT,QT/A,SHB1,SHB3,SHB3/A,VXG
			1	-	-	2205609	ETS,ETX
5	87522-ZH8-W40	MARK, CAUTION (PICTOGRAPH) ..	1	-	-	-----	LHQ4,LXE4,LXQ4,PKT4,PKX4,QHQ4,QKA4,QMEO,QXB7,QXC4,QXE4,QXQ4,SHQ4,SMEO,SXB7,SXE4,SXQ4,VD16,VEB6,VXB7,VXE4,VXE7,VXQ4
			1	-	-	2337465	QE,QXB,SE,SXB,SXEB,VXB,VXEB,VXG
			1	-	-	2398545	LKE
			1	-	-	3727690	LHQ4/A,LKE/A,LXE4/A,LXQ4/A,PKT4/A,PKX4/A,QE/A,QHQ4/A,QKA4/A,QMEO/A,QXB/A,QXB7/A,QXC4/A,QXE4/A,QXQ4/A,SE/A,SHQ4/A,SMEO/A,SXB/A,SXB7/A,SXEB/A,SXE4/A,SXQ4/A,VXB/A,VXB7/A,VXEB/A,VXE7/A,VXQ4/A
	87522-ZH8-W41	.....	1	-	-	3727691	LHQ4/A,LKE/A,LXE4/A,LXQ4/A,PKT4/A,PKX4/A,QE/A,QHQ4/A,QKA4/A,QMEO/A,QXB/A,QXB7/A,QXC4/A,QXE4/A,QXQ4/A,SE/A,SHQ4/A,SMEO/A,SXB/A,SXB7/A,SXEB/A,SXE4/A,SXQ4/A,VXB/A,VXB7/A,VXEB/A,VXE7/A,VXQ4/A
6	87522-ZH8-W40	MARK, CAUTION (PICTOGRAPH) ..	1	-	-	3727690	VSH7
			-	-	1	1000021	VXQP
	87522-ZH8-W41	.....	1	-	-	3727691	VSH7
	87516-Z0D-800	MARK, OPERATOR CAUTION .....	1	-	-	-----	EDT3,ES2,VS2,VS7
7	87522-ZH9-000	LABEL, CAUTION (ENGLISH, ETC.)	1	(1)	-	-----	ED7,ES,HH,HX,LHB1,LHC,LHW,LP,LXE6,LXZ,P1,P1/A,QHC,QNE6,QXEB,Q1,Q1/A,SHB1,SHE,SHEZ,S1,S1/A,VE,VH,VHE,VMX,VXB2,VXE6,V1
			1	-	-	2337464	QE,QXB,SE,SXB,SXEB,VXB,VXEB,VXG
			1	-	-	2398544	LKE
	87522-ZH9-820	LABEL, CAUTION (THAI) .....	1	-	-	-----	LT,QT
			1	-	-	3732694	LT/A,QT/A
	87522-ZH9-010	LABEL, CAUTION (ENGLISH, ETC.)	1	(1)	-	-----	ED8,ED8/A,ED9,ED9/A,ES1,ES1/A,HA2,HA2/A,HX26,HX26/A,LH,LH/A,LHB3,LHB3/A,LHB5,LHE,LHE/A,LXE,LXE/A,LXE2,LXE2/A,LXE8,LXE8/A,LXU,LXU/A,LX26,LX26/A,L1,L1/A,PX,PX/A,PXA2,PXE8,PXE8/A,QAB2,QAB2/A,QAC2,QAC2/A,QAE2,QAE2/A,QAE6,QAE6/A,QAG,QAG/A,QA2,QA2/A,QAP2,QAP2/A,QA2,QA2/A,QA26,QA26/A,QDW9,QDW9/A,QH,QH/A,QHB3,QHB3/A,QHB5,QHE,QHE/A,QHP1,QHP1/A,QME8,QME8/A,QMH,QMH/A,QMT2,QMT2/A,QNE2,QNE2/A,QNE9,QNE9/A,QNR2,QNR2/A,QNR6,QNR6/A,QP,QP/A,QT2,QT2/A,QWH2,QWH2/A,QX,QX/A,QXC6,QXC6/A,QXC9,QXC9/A,QXE,QXE/A,QXE6,QXE6/A,QXE8,QXE8/A,QXU,QXU/A,SH,SH/A,SHB3,SHB3/A,SMX2,SMX2/A,STP,STP/A,STQ,STQ/A,SWX,SWX/A,SX,SX/A,SXE,SXE/A,SXE8,SXE8/A,SXU,SXU/A,VAD2,VAD2/A,VA2,VA2/A,VDE2,VDE2/A,VWC2,VWC2/A,VWS2,VWS2/A,VX,VX/A,VXE2,VXE2/A,VXE8,VXE8/A,VXU,VXU/A,VXU1,VXU1/A,VX16,VX16/A,VX8,VX8/A
			1	-	-	3732695	LT/A,QT/A
	87516-ZM7-801	MARK, OPERATOR CAUTION .....	1	-	-	-----	EDK,EDS4,VS4,VS6,VXK
8	87522-ZH9-000	LABEL, CAUTION (ENGLISH, ETC.)	-	-	1	1000020	VXQP



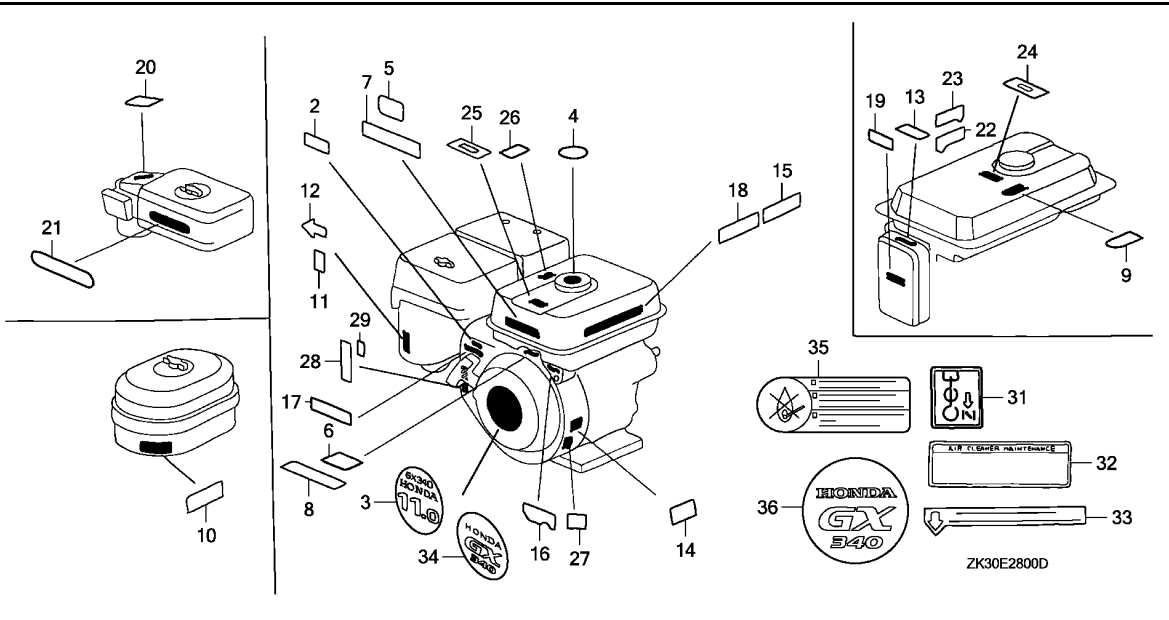

Ref. No.	Part No.	Description	Reqd. QTY			Serial No.	Parts catalogue code
			GX 340K1	(1)	(2)		
9	87522-883-660	MARK, CAUTION (ENGLISH/FRENCH/SPANISH)	1	-	-	-----	EDS3,EDS5,EDS6,EDS6/A,EDT6,EDT6/A,ED6,ED6/A,EN6,EN6/A,VTE2
10	87524-883-690	MARK, AIR CLEANER CAUTION (OIL BATH)(ARABIC)	1	-	-	2186194	----- EDS
11	87528-ZE2-810	MARK, CHOKE (ORANGE)	1	-	-	-----	LT,LT/A,QP,QP/A,QT,QT/A,SWX,SWX/A
						-----	EDK,EDN5,EDN5/A,ED7,ED8,ED8/A,ED9,ED9/A,EN,ES,ES1,ES1/A,ES2,ET ETS,ETX,HH,HX,HX26,HX26/A,LH,LH/A,LHB1,LHB3,LHB3/A,LHB5,LHC,LHE LHE/A,LHW,LXE,LXE/A,LXE6,LXE8,LXE8/A,LXU,LXU/A,LXZ,LX26,LX26/A,PX PX/A,PXA2,PXE8,PXE8/A,QAE6,QAE6/A,QA26,QA26/A,QH,QH/A,QHB3,QHB3/A QHB5,QHC,QHE,QHE/A,QHP1,QHP1/A,QME8,QME8/A,QMH,QMH/A,QNE6,QNR6 QNR6/A,QP,QP/A,QX,QX/A,QXC6,QXC6/A,QXE,QXE/A,QXEB,QXE6,QXE6/A QXE8,QXE8/A,QXU,QXU/A,SH,SH/A,SHB1,SHB3,SHB3/A,SHE,SHEZ,SHT,SWX SWX/A,SX,SX/A,SXE,SXE/A,SXE8,SXE8/A,SXU,SXU/A,VAA,VAAE,VE,VH,VHE VMX,VNG,VX,VX/A,VXB2,VXE6,VXE8,VXE8/A,VXK,VXU,VXU/A,VXU1,VXU1/A VX16,VX16/A,VX8,VX8/A
			1	-	-	2602235	----- VD16,VEB6
			1	-	-	2337464	----- QE,QXB,SE,SXB,SXEB,VNG1,VNG2,VXB,VXEB,VXG
			1	-	-	2398544	----- LKE
			-	(1)	-	-----	
	87528-ZE1-690	MARK, CHOKE (THAI)	1	-	-	-----	LT,LT/A,QP,QP/A,QT,QT/A
	87528-ZF6-W40	MARK, CHOKE (BLACK)	1	-	-	-----	LHQ4,LHQ4/A,LKE/A,LXE4,LXE4/A,LXQ4,LXQ4/A,PKT4,PKT4/A,PKX4,PKX4/A QE/A,QHQ4,QHQ4/A,QKA4,QKA4/A,QMED,QMED/A,QXB/A,QXB7/A,QXC4 QXC4/A,QXE4,QXE4/A,QXQ4,QXQ4/A,SE/A,SHQ4,SHQ4/A,SMED,SMED/A,SXB/A SXB7,SXB7/A,SXEB/A,SXE4,SXE4/A,SXQ4,SXQ4/A,VSH7,VXB/A,VXB7,VXB7/A VXEB/A,VXE4,VXE7,VXE7/A,VXQ4,VXQ4/A
			1	-	-	2337465	----- QE,QXB,SE,SXB,SXEB,VNG1,VNG2,VXB,VXEB,VXG
			1	-	-	2398545	----- LKE
			1	-	-	2602234	----- VD16,VEB6

Ref. No.	Part No.	Description	Reqd. QTY			Serial No.	Parts catalogue code	
			(1)	(2)	(3)			
12	87528-883-661	MARK, CHOKE .....	-	-	1			
13	87528-898-620	MARK, CHOKE .....	1	-	-	-----	EDN,EDS,EDS3,EDS4,EDS6,EDS6/A,EDT6,EDT6/A,ED6,ED6/A,EMT,EMT/A,EN6 EN6/A,ES3,ES3/A,ES4,ES4/A,VMQ,VMT,VMT/A,VS4,VS6,VTE2	
14	87530-ZE3-W10	LABEL, SPECIFICATION (EXTERNAL)	1	(1)	-	-----	2205609 EDN,EDS,ED6,ED7,ED8,ED9,ES,ES1,ETS,ETX,HH,HX,LH,LHC,LHE,LKE,LXE LXZ,L1,PX,P1,QE,QH,QHC,QHE,QP,QT,QX,QXB,QXE,QXEB,Q1,SE,SH,SHE SHEZ,SWX,SX,SXB,SXE,SXEB,S1,VAA,VAE,VE,VH,VHE,VNG1,VNG2,VX VXB,VXEB,V1	
15	87532-ZB4-G60	MARK, OIL ALERT (GERMAN) ....	1	(1)	-	-----	EN,ES3,ES3/A,ES4,ES4/A,ET ED9/A,ES1/A,LXE/A,LXE6,LXE8,LXE8/A,LXU,LXU/A,L1/A,PX/A,P1/A,QNR6 QNR6/A,QX/A,QXB/A,QXC6,QXC6/A,QXE/A,QXE8,QXE8/A,QXU,QXU/A,Q1/A SHT,SWX/A,SX/A,SXB/A,SXE/A,SXEB/A,SXE8,SXE8/A,SXU,SXU/A,S1/A,VX/A VXB/A,VXB2,VXEB/A,VXE8,VXE8/A,VXG,VXU,VXU/A,VXU1,VXU1/A,VX16 VX16/A,VX8,VX8/A	
			1	(1)	-	2215598	-----	ED9,ES1,HX,LXE,LXZ,L1,PX,P1,QX,QXB,QXE,QXEB,Q1,SWX,SX,SXB,SXE SXEB,S1,VAA,VAE,VNG,VNG1,VNG2,VX,VXB,VXEB,V1
	87532-ZB4-H50	MARK, OIL ALERT (FRENCH) ....	1	(1)	-	2215598	2398544	LKE ED9/A,ES1/A,HX26/A,LKE/A,LXE/A,LXE6,LXE8,LXE8/A,LXU,LXU/A,LX26 LX26/A,L1/A,PX/A,P1/A,QAE6,QAE6/A,QA26,QA26/A,QNR6,QNR6/A,QX/A QXC6,QXC6/A,QXE/A,QXE6,QXE6/A,QXE8,QXE8/A,QXU,QXU/A,Q1/A,SHT SWX/A,SX/A,SXE/A,SXE8,SXE8/A,SXU,SXU/A,S1/A,VX/A,VXB2,VXE8,VXE8/A VXU,VXU/A,VXU1,VXU1/A,VX16,VX16/A,VX8,VX8/A
			1	(1)	-	2215598	-----	ED9,ES1,HX,LKE,LXE,LXZ,L1,PX,P1,QX,QXE,QXEB,Q1,SWX,SX,SXE,S1,VAA VAE,VNG,VX,V1
			1	-	-	2602235	-----	HX26,VD16,VEB6
			1	-	-	2338523	-----	VXG
			1	-	-	2215598	2338523	QXB,SXB,SXEB,VNG1,VNG2,VXB,VXEB
16	87532-ZE1-810	MARK, OIL ALERT (EXTERNAL) ..	1	(1)	-	-----	2143683	ES1,HX,LXZ,L1,PX,P1,QX,QXB,Q1,SWX,SX,SXB,S1,VAA,VNG,VNG1,VX,VXB V1
17	87532-ZH8-W40	MARK, THROTTLE INDICATION ...	1	-	-	-----	LHQ4,LHQ4/A,LKE/A,LXE4,LXE4/A,LXQ4,LXQ4/A,PKT4,PKT4/A,PKX4,PKX4/A QE/A,QHQ4,QHQ4/A,QKA4,QKA4/A,QMED,QMED/A,QXB/A,QXB7,QXB7/A,QXC4 QXC4/A,QXE4,QXE4/A,QXQ4,QXQ4/A,SE/A,SHQ4,SHQ4/A,SMED,SMED/A,SXB/A SXB7,SXB7/A,SXEB/A,SXE4,SXE4/A,SXQ4,SXQ4/A,VD16,VEB6,VSH7,VXB7/A VXB7,VXB7/A,VXEB/A,VXE4,VXE7,VXE7/A,VXQ4,VXQ4/A	
			1	-	-	2337465	-----	QE,QXB,SE,SXB,SXEB,VNG1,VNG2,VXB,VXEB
			1	-	-	2398545	-----	LKE
18	87532-ZH8-810	MARK, OIL ALERT (EXTERNAL) ..	1	1	1	-----	EDN5,EDN5/A,ED9,ED9/A,ES1/A,ES2,HX26,HX26/A,LKE/A,LXE/A,LXE6,LXE8 LXE8/A,LXU,LXU/A,LX26,LX26/A,L1/A,PX/A,PXE8,PXE8/A,P1/A,QAE6 QAE6/A,QA26,QA26/A,QME8,QME8/A,QNE6,QNR6,QNR6/A,QX/A,QXC6,QXC6/A QXE/A,QXE6,QXE6/A,QXE8,QXE8/A,QXU,QXU/A,Q1/A,SHT,SWX/A,SX/A,SXE/A SXE8,SXE8/A,SXU,SXU/A,S1/A,VD16,VEB6,VMX,VX/A,VXB2,VXE6,VXE8 VXE8/A,VXP,VXU,VXU/A,VXU1,VXU1/A,VX16,VX16/A,VX8,VX8/A	
			1	1	-	2143684	-----	ES1,HX,LKE,LXE,LXZ,L1,PX,P1,QX,QXE,QXEB,Q1,SWX,SX,SXE,S1,VAA,VAE VNG,VX,V1
			1	-	-	2338523	-----	VXG
			1	-	-	2143684	2338523	QXB,SXB,SXEB,VNG1,VNG2,VXB,VXEB
19	87533-ZC0-630	MARK, AIR CLEANER .....	1	-	-	-----	EDN,EDS,EDS3,EDS6,EDS6/A,EDT6,EDT6/A,ED6,ED6/A,EMT,EMT/A,EN6 EN6/A,ES3,ES3/A,ES4,ES4/A,VMQ,VMT,VMT/A,VTE2	
	87533-ZB6-750	.....	1	-	-	-----	EDS5	
20	87534-ZE1-841	LABEL, AIR CLEANER CAUTION ..	-	(1)	-	-----	LHC,QHC,QXC6,QXC6/A,SHT	
21	87535-ZE1-840	MARK, AIR CLEANER SALES POINT	1	(1)	-	-----	LHC,L1,P1,QHC,QXC4,QXC6,Q1,SHT,S1,V1	
	87535-ZE1-841	.....	1	(1)	-	3670223	-----	L1/A,P1/A,QXC4/A,QXC6/A,Q1/A,S1/A
22	87539-ZB2-630	MARK, EX. CAUTION .....	1	-	-	-----	L1/A,P1/A,QXC4/A,QXC6/A,Q1/A,S1/A EDS5	



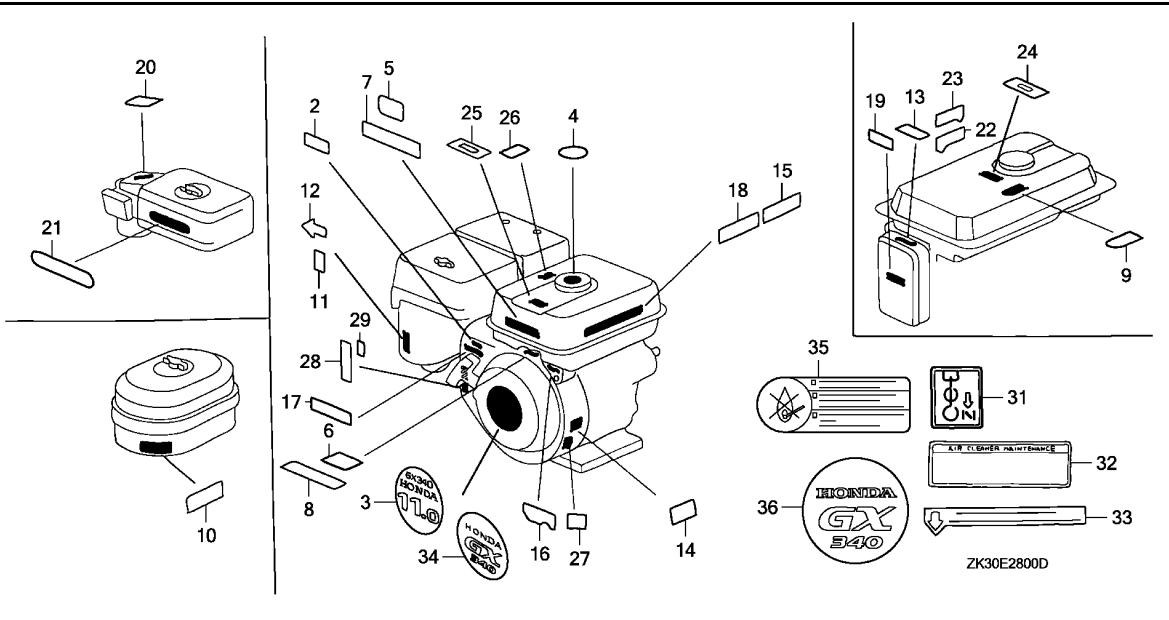

Ref. No.	Part No.	Description	Reqd. QTY			Serial No.	Parts catalogue code
			GX 340K1 (1)	(2)	(3)		
23	87539-898-620	MARK, EX. CAUTION (ENGLISH/FRENCH)	1	-	-	-----	EDS,EDS3,EDS6,EDS6/A,EDT6,EDT6/A,ED6,ED6/A,EMT,EMT/A,EN6,EN6/A ES3,ES3/A,ES4,ES4/A,VMQ,VMT,VMT/A,VTE2
24	87565-ZB4-A00	PLATE, FUEL INDICATION .....	1	-	-	-----	EDS,EDS5,ED6/A,EMT,EMT/A,SHT,VMQ,VMT,VMT/A,VTE2
25	87565-ZE2-810	MARK, FUEL INDICATION (ENGLISH)	1	-	-	-----	2337464 VXG
	87565-ZE2-A01	MARK, FUEL INDICATION (PICTOGRAPH)	-	(1)	-	-----	2337465 VXG
26	87586-ZH7-W00	LABEL, FUEL CAUTION .....	2	-	-	-----	ED6/A
	87532-ZH8-810	MARK, OIL ALERT (EXTERNAL) ..	2	-	-	-----	2374606 ED6
27	87594-ZB4-A00	MARK, OIL CAUTION .....	1	-	-	-----	PXA2
28	87135-ZE2-010	LABEL, E-SPEC (EPA STANDARD) (15.5X60.0)	1	1	-	-----	EDN,EDN5,EDN5/A,EDS,EDS3,EDS4,EDS5,EDS6,EDS6/A,EDT3,EDT6,EDT6/A ED6,ED6/A,EN6,EN6/A,ES,ES1,ES1/A,ES2,VTE2
			1	-	-	-----	EDN5,EDS6,EDT6,ED8,ED9,ES1,ES3,ES4,LH,LHB3,LHE,LHQ4,LKE,LT,LXE LXE4,LXE8,LXQ4,LXU,L1,PKT4,PKX4,PX,PXE8,QE,QH,QHB3,QHE,QHP1,QHQ4 QKA4,QME0,QME8,QMH,QP,QX,QXB,QXC4,QXE,QXE4,QXE8,QXQ4,QXU,Q1,SE,SH SHB1,SHB3,SHQ4,SMEO,SWX,SX,SXB,SXE,SXEB,SXE4,SXE8,SXQ4,SXU,VMT,VX VXB,VXEB,VXE8,VXQ4,VXU,VXU1,VX8
			-	-	1	-----	EMT,QXB7,SXB7,VXB7,VXE7



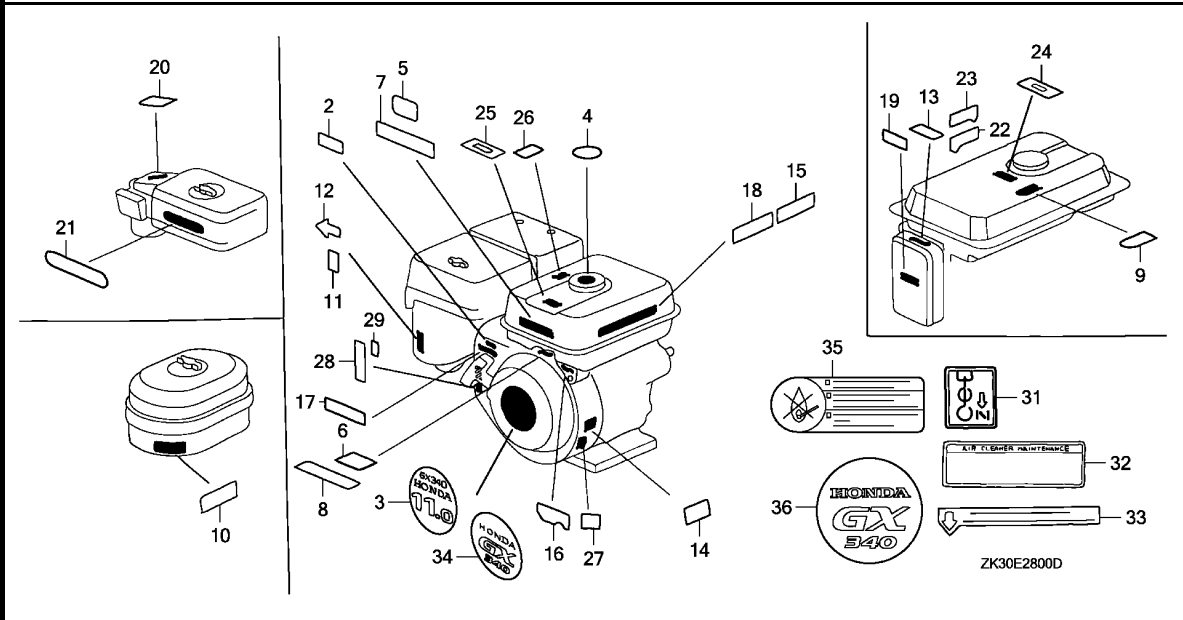

Ref. No.	Part No.	Description	Reqd. QTY			Serial No.	Parts catalogue code
			GX 340K1 (1)	(2)	(3)		
28)	87135-ZE2-020	LABEL, E-SPEC (15.5X27.5) ...	1	1	-	3989217	EDN5/A,ED8/A,ED9/A,EMT/A,ES1/A,ES3/A,ES4/A,LH/A,LHB3/A,LHB5,LHE/A,LT/A,LXE/A,LXE8/A,LXU/A,L1/A,PX/A,PXE8/A,P1/A,QH/A,QHB3/A,QHB5,QHE/A,QHP1/A,QME8/A,QMH/A,QP/A,QX/A,QXE/A,QXE8/A,QXU/A,Q1/A,SH/A,SHB3/A,SKE/A,SKZ/A,STR/A,SWX/A,SX/A,SXE/A,SXE8/A,SXU/A,S1/A,VMQ,VMT/A,VS3,VS5,VX/A,VXE8/A,VXU/A,VXU1/A,VX8/A
			1	-	-	3851715	EDS6/A,EDT6/A,LHQ4/A,LKE/A,LXE4/A,LXQ4/A,PKT4/A,PKX4/A,QE/A,QHQ4/A,QKA4/A,QMEO/A,QXB/A,QXB7/A,QXC4/A,QXE4/A,QXQ4/A,SE/A,SHQ4/A,SME0/A,SXB/A,SXB7/A,SXEB/A,SXE4/A,SXQ4/A,VSH7,VXB/A,VXB7/A,VXEB/A,VXE7/A,VXQ4/A
29	87114-ZH7-000	LABEL, WARNING (NOT CERTIFIED FOR SALE)	1	1	-	3912093	LH/A,LHB3/A,LHB5,LHE/A,LT/A,LXE/A,P1/A,QH/A,QHB3/A,QHB5,QHE/A,QHP1/A,QMH/A,QP/A,QT/A,QX/A,QXE/A,SH/A,SHB3/A,SWX/A,SX/A,SXE/A,VMQ,VMT/A,VX/A
			1	1	-	3982175	EDN5/A,ED8/A,ED9/A,EMT/A,ES1/A,ES3/A,ES4/A,L1/A,PX/A,Q1/A,S1/A,VXU/A,VXU1/A
			1	-	-	3970135	EDK,EDS4,EDT3,ES2,VS2,VS4,VS6,VS7,VXK
31	87528-898-620	MARK, CHOKE .....	1	-	-		VS3,VS5
32	87533-ZC0-630	MARK, AIR CLEANER .....	1	-	-		EDS4,EDT3,VS2,VS3,VS4,VS5,VS6,VS7
33	87539-898-620	MARK, EX. CAUTION (ENGLISH/FRENCH)	1	-	-		EDS4,EDT3,VS2,VS3,VS4,VS5,VS6,VS7
34	87521-ZE3-W04	EMBLEM (GX340) .....	1	(1)	-	4072395	EDS4,EDT3,VS2,VS3,VS4,VS5,VS6,VS7
			1	-	-		EDK,EDN5/A,EDS4,ED8/A,ED9/A,EMT/A,ES1/A,ES3/A,ES4/A,LH/A,LHB3/A,LHB5,LHE/A,LT/A,LXE/A,L1/A,PX/A,P1/A,QH/A,QHB3/A,QHB5,QHP1/A,QMH/A,QP/A,QT/A,QX/A,QXE/A,Q1/A,SH/A,SX/A,SXE/A,S1/A,VMQ,VMT/A,VS3,VS4,VS5,VS6,VX/A,VXEB/A,VXK,VXU/A,VXU1/A
35	87522-883-660	MARK, CAUTION (ENGLISH/FRENCH/SPANISH)	1	-	-		EDT3,ES2
			1	-	-		EDT3
36	87521-ZE3-W04	EMBLEM (GX340) .....	1	-	-		VS2,VS7



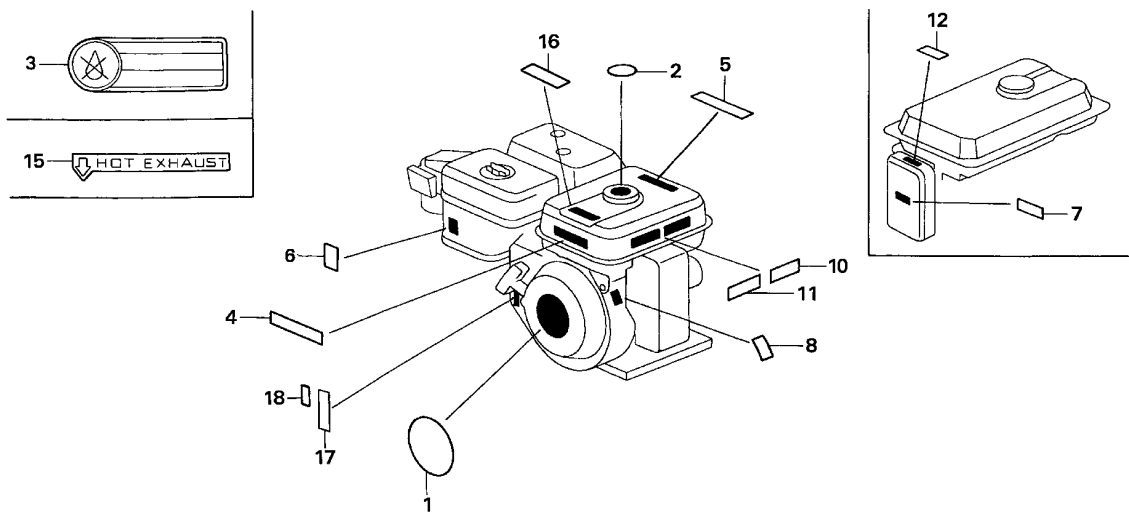

ZK30-E2801A

Ref. No.	L.O.N.	(Relative ref. Number)	Description	F.R.T.
----------	--------	------------------------	-------------	--------

NO INFORMATION .....

Ref. No.	Part No.	Description	Reqd. QTY			Serial No.	Parts catalogue code
			GX 340K1	(1)	(2)		
1	87521-ZE3-W02	EMBLEM (GX340 HONDA 11.0) ...	1	-	-	-----	BJ,EDS1,EDT1,LJ,LJG,LJS,LSX,SJ,SJG,SKE,SKZ,STJ,STP,STQ,STR,YJ
			1	-	-	3663825	EDS1/A,EDT1/A,ENT2,LJ/A,LJG/A,LJS/A,SJ/A,SJG/A,SKE/A,SKZ/A,STJ/A
	87521-ZE3-W03	.....	1	-	-	3663826	STP/A,STQ/A,STR/A
			1	-	-	4072394	ENT2
			1	-	-	3663826	LJS1
			1	-	-	4072394	EDS1/A,EDT1/A,LJ/A,LJG/A,LJS/A,SJ/A,SJG/A,SKE/A,SKZ/A,STJ/A,STP/A
	87521-ZE3-W04	EMBLEM (GX340) .....	1	-	-	4072395	STQ/A,STR/A
			1	-	-	4072395	EDS1/A,EDT1/A,LJ/A,LJG/A,LJS/A,LJS1,SJ/A,SJG/A,SKE/A,SKZ/A,STJ/A
			1	-	-	4072395	STP/A,STQ/A,STR/A
2	87522-ZE1-010	LABEL, FUEL WARNING .....	1	-	-	2205608	BJ,LJ,SJ,STJ,YJ
	87522-ZE1-810	MARK, CAUTION .....	1	-	-	2205609	BJ,LJ,SJ,STJ,YJ
3	87522-883-660	MARK, CAUTION (ENGLISH/FRENCH/SPANISH)	1	-	-	-----	EDS1,EDS1/A,EDT1,EDT1/A
4	87520-ZH8-000	MARK A, COMBINATION .....	1	-	-	-----	LJ/A,LJG/A,LJS,LJS/A,LJS1,LSX,LWD,SJ/A,SJG/A,SKE,SKE/A,SKZ,SKZ/A
			1	-	-	2448575	STJ/A,STP,STP/A,STQ,STQ/A,STR,STR/A
			1	-	-	2448575	BJ,LJ,LJG,SDE,SJ,SJG,STJ,YJ
5	87526-ZH8-000	MARK B, COMBINATION .....	1	-	-	-----	LJ/A,LJG/A,LJS,LJS/A,LJS1,LSX,LWD,SJ/A,SJG/A,SKE,SKE/A,SKZ,SKZ/A
			1	-	-	2448575	STJ/A,STR,STR/A
			1	-	-	2448575	BJ,LJ,LJG,SDE,SJ,SJG,STJ,YJ
6	87528-ZE2-000	MARK, CHOKE (INTERNAL) .....	1	-	-	2209470	BJ,LJ,SJ,STJ,YJ
	87528-ZE2-810	MARK, CHOKE (ORANGE) .....	1	-	-	-----	LJ/A,LJG,LJG/A,LJS,LJS/A,LJS1,LSX,SDE,SJ/A,SJG,SJG/A,SKE,SKE/A
			1	-	-	2209471	SKZ,SKZ/A,STJ/A,STP,STP/A,STQ,STQ/A,STR,STR/A
			1	-	-	2209471	BJ,LJ,SJ,STJ,YJ
7	87528-898-620	MARK, CHOKE .....	1	-	-	-----	EDS1,EDS1/A,EDT1,EDT1/A,ENT2
8	87530-ZE3-W00	LABEL, SPECIFICATION (INTERNAL)	1	-	-	-----	SDE,YJ
			1	-	-	3611393	SJ,SJG,SKE,SKZ,STJ,STR

Ref. No.	Part No.	Description	Reqd. QTY			Serial No.	Parts catalogue code
			(1)	(2)	(3)		
(8)	87530-ZE3-W40	LABEL, SPECIFICATION (INTERNAL-L TYPE)	1	(1)	-	-----	BJ,LJ,LJG,L1
			1	-	-	-----	3610644 LJG/A
			1	-	-	-----	3618032 LJ/A
			-	(1)	-	-----	3611390 L1/A
	87594-ZB4-A00	MARK, OIL CAUTION .....	1	-	-	-----	EDS1,EDS1/A,EDT1,EDT1/A,ENT2
	87530-ZE3-W01	LABEL, SPECIFICATION .....	1	-	-	-----	SJ/A,SJG/A,SKE/A,SKZ/A,STJ/A,STR/A
			1	-	-	3611394	SJ,SJG,SKE,SKZ,STJ,STR
	87530-ZE3-W41	.....	1	-	-	-----	LJS,LJS/A,LJS1,LWD
			1	-	-	3610645	LJG/A
			1	-	-	3618033	LJ/A
			-	1	-	3611391	L1/A
10	87532-ZB4-G60	MARK, OIL ALERT (GERMAN) ....	1	-	-	-----	STP/A
			1	-	-	2215598	STP
11	87532-ZH8-000	MARK, OIL ALERT (INTERNAL) ..	1	-	-	-----	LSX
12	87533-ZC0-630	MARK, AIR CLEANER .....	1	-	-	-----	EDS1,EDS1/A,EDT1,EDT1/A,ENT2
15	87539-898-620	MARK, EX. CAUTION (ENGLISH/FRENCH)	1	-	-	-----	EDS1,EDS1/A,EDT1,EDT1/A
16	87565-ZB4-A00	PLATE, FUEL INDICATION .....	1	-	-	-----	STR,STR/A
	87565-ZE2-000	MARK, FUEL INDICATION (JAPANESE)	1	-	-	-----	LJG,LJG/A,LJS,LJS/A,LJS1,LWD,LWD1,LWD1/A,SDE,SJG,SJG/A,SKE,SKE/A,SKZ,SKZ/A,STJ,STJ/A
17	87135-ZE2-010	LABEL, E-SPEC (EPA STANDARD) (15.5X60.0)	1	-	-	-----	LJS
			1	-	-	3334264	EDS1,EDT1,LJ,LJG,LWD1,SJ,SJG,SKE,SKZ,STJ,STP,STQ,STR,ZK1
	87135-ZE2-020	LABEL, E-SPEC (15.5X27.5) ...	1	-	-	3989217	LJ/A,LJG/A,LJS/A,LJS1,LWD,LWD1/A,SJ/A,SJG/A,SKE/A,SKZ/A,STJ/A,STP/A,STQ/A,STR/A,ZK1/A
			1	-	-	3334264	3989217 EDS1/A,EDT1/A
18	87114-ZH7-000	LABEL, WARNING (NOT CERTIFIED FOR SALE)	1	-	-	3912093	LJ/A,LJG/A,LJS/A,LJS1,LWD,LWD1/A,SJ/A,SJG/A,SKE/A,SKZ/A,STJ/A,STR/A
			1	-	-	3982175	EDS1/A,EDT1/A,STP/A,STQ/A,ZK1/A



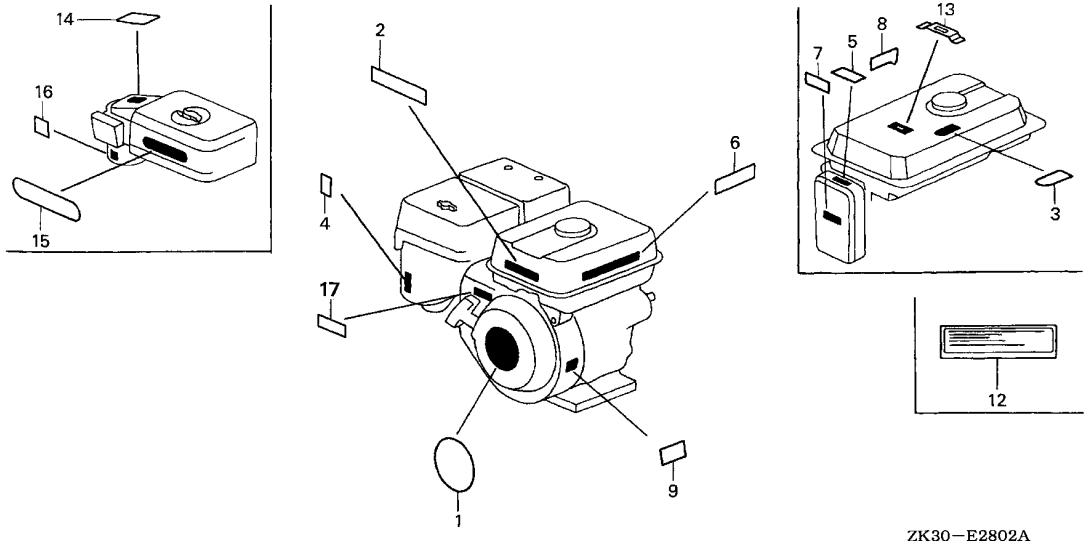

ZK30-E2802A

Ref. No.	L.O.N.	(Relative ref. Number)	Description	F.R.T.
----------	--------	------------------------	-------------	--------

NO INFORMATION .....

Ref. No.	Part No.	Description	Reqd. QTY			Serial No.	Parts catalogue code
			GX 340K1 (1)	(2)	(3)		
1	87521-ZE3-W02	EMBLEM (GX340 HONDA 11.0) ...	1	-	-	EDS2,EDT,EDT2,ENT,QAB2,QAC2,QAG,QA2,QL2,QMX2,QWH2,VC2,VWC2,VWS2	
	87521-ZE3-W03	.....	1	-	-	3663825 EDS2/A,EDT/A,ENT/A,QAB2/A,QAC2/A,QAG/A,QA2/A,QWH2/A,VC2/A,VWC2/A	
	87521-ZE3-W03	.....	1	-	-	VWS2/A	
	87521-ZE3-W03	.....	1	-	-	3663826 VWC	
	87521-ZE3-W03	.....	1	-	-	EDS2/A,EDT/A,ENT/A,QAB2/A,QAC2/A,QAG/A,QA2/A,QWH2/A,VC2/A,VWC2/A	
2	87522-ZH8-W41	MARK, CAUTION (PICTOGRAPH) ..	1	-	-	VWS2/A	
	87522-ZH8-W41	.....	1	-	-	3930788 VWC	
	87522-ZH8-W41	.....	1	-	-	QAG/A,VWC2/A,VWS2/A	
	87522-ZH9-000	LABEL, CAUTION (ENGLISH, ETC.)	1	-	-	QAB2,QAB2/A,QAG,QA2,QA2/A,QL2,QMX2,QWH2,QWH2/A,VWC2,VWS2	
	87522-ZH9-000	.....	1	-	-	3930787 QAG/A,VWC2/A,VWS2/A	
	87522-ZH9-010	.....	1	-	-	VWC	
	87522-ZH9-010	.....	1	-	-	3930788 QAG/A,VWC2/A,VWS2/A	
3	87522-883-660	MARK, CAUTION (ENGLISH/FRENCH/SPANISH)	1	-	-	EDS2,EDS2/A,EDT,EDT/A,EDT2,ENT,ENT/A,VC2,VC2/A,VWC	
4	87528-ZE2-810	MARK, CHOKE (ORANGE) .....	1	-	-	QAB2,QAB2/A,QAC2,QAC2/A,QAG,QAG/A,QA2,QA2/A,QL2,QMX2,QWH2	
	87528-ZE2-810	.....	1	-	-	QWH2/A,VWC2,VWC2/A,VWS2,VWS2/A	
	87528-ZH7-000	MARK, CHOKE (GRAY) .....	1	-	-	3930788 QAG/A,VWC2/A,VWS2/A	
5	87528-898-620	MARK, CHOKE .....	1	-	-	EDS2,EDS2/A,EDT,EDT/A,EDT2,ENT,ENT/A,VC2,VC2/A,VWC	
6	87532-ZB4-G60	MARK, OIL ALERT (GERMAN) ....	1	-	-	VWC2,VWC2/A,VWS2,VWS2/A	
	87532-ZB4-H50	MARK, OIL ALERT (FRENCH) ....	1	-	-	VWC2,VWC2/A,VWS2,VWS2/A	
	87532-ZH8-810	MARK, OIL ALERT (EXTERNAL) ..	1	-	-	QAB2,QAB2/A,QAC2,QAC2/A,QAG,QA2,QA2/A,QL2,QMX2,QWH2,QWH2/A,VWC	
	87532-ZH8-810	.....	1	-	-	VWC2,VWS2	
	87532-ZH8-810	.....	1	-	-	3930787 QAG/A,VWC2/A,VWS2/A	
7	87533-ZC0-630	MARK, AIR CLEANER .....	1	-	-	EDS2,EDS2/A,EDT,EDT/A,EDT2,ENT,ENT/A,VC2,VC2/A,VWC	
8	87539-898-620	MARK, EX. CAUTION (ENGLISH/FRENCH)	1	-	-	EDS2,EDS2/A,EDT,EDT/A,EDT2,ENT,ENT/A,VC2,VC2/A,VWC	
9	87594-ZB4-A00	MARK, OIL CAUTION .....	1	-	-	EDS2,EDS2/A,EDT,EDT/A,EDT2,ENT,ENT/A,VC2,VC2/A,VWC	



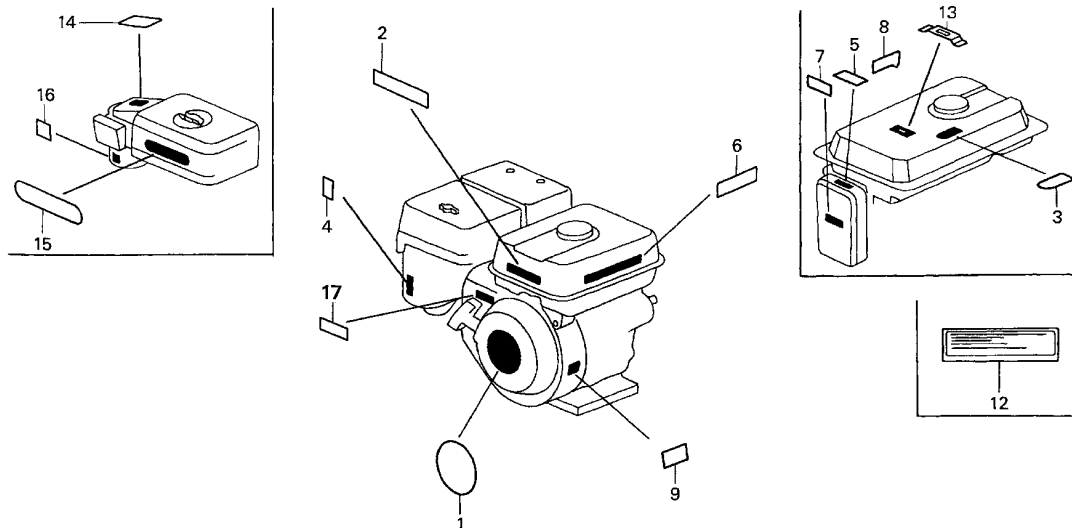

ZK30-E2802A

Ref. No.	Part No.	Description	Reqd. QTY			Serial No.	Parts catalogue code
			GX 340K1 (1)	(2)	(3)		
(9)	87532-ZH8-810	MARK, OIL ALERT (EXTERNAL) ..	1	-	-	-----	QAB2,QAB2/A,QAC2,QAC2/A,QAG,QAG/A,QAH2,QAH2/A,QWH2,QWH2/A,VWC VWC2,VWC2/A,VWS2,VWS2/A
12	87522-ZH9-000	LABEL, CAUTION (ENGLISH, ETC.)	1	-	-	-----	QAC2,QAC2/A
13	87565-ZB4-A00	PLATE, FUEL INDICATION .....	1	-	-	-----	EDT,EDT/A,ENT,ENT/A
14	87534-ZE1-841	LABEL, AIR CLEANER CAUTION ..	1	-	-	-----	QWH2,QWH2/A
15	87535-ZE1-840	MARK, AIR CLEANER SALES POINT	1	-	-	-----	QWH2
	87535-ZE1-841	.....	1	-	-	3807628	QWH2/A
	87535-ZE1-841	.....	1	-	-	3807629	QWH2/A
16	87528-ZE2-810	MARK, CHOKE (ORANGE) .....	1	-	-	-----	QWH2,QWH2/A
17	87532-ZH8-W40	MARK, THROTTLE INDICATION ...	1	-	-	3930681	QAG/A,VWC2/A,VWS2/A



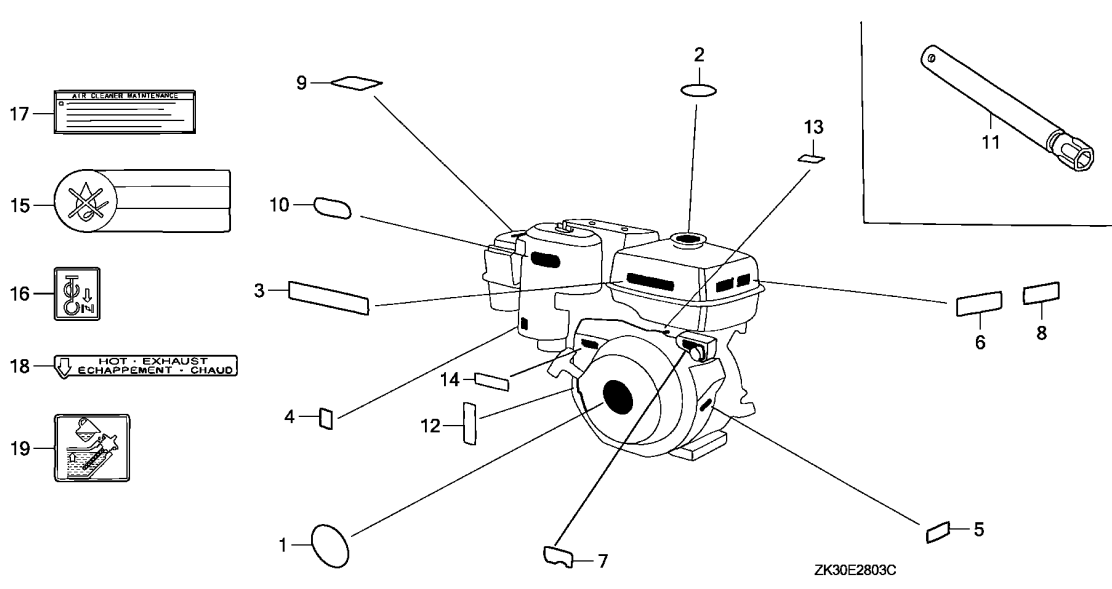

Ref. No.	L.O.N.	(Relative ref. Number) Description	F.R.T.
----------	--------	------------------------------------	--------

NO INFORMATION .....

Ref. No.	Part No.	Description	Reqd. QTY			Serial No.	Parts catalogue code
			GX 340K1	(1)	(2)		
1	87521-ZE3-W10	EMBLEM (GX340 HONDA 11.OHP) (ELECTRONIC IGNITION)	1	-	-	2143835	HA, LX, QA, QAE, QAP, QAPE, QNE, QXC, SXP, VA, VAH1, VAH2, VXA, VXE
	87521-ZE3-W02	EMBLEM (GX340 HONDA 11.0) ...	1	-	-	-----	HAQ, HA2, HX2, LX2, QAE2, QAP2, QAQ, QA2, QH2, QNE2, QNE9, QN18, QPE2, QXC9, QXE2, QX2, VAW1, VA2, VDE, VH12, VWA, VXE2
			1	-	-	2143836	HA, LX, QA, QAE, QAP, QAPE, QNE, QXC, SXP, VA, VAH1, VAH2, VXA, VXE
			1	-	-	3663825	HA2/A, LX/A, LX2/A, QAE2/A, QAP2/A, QA2/A, QNE2/A, QNE9/A, QXC/A, QXC9/A, VA2/A, VH12/A, VXE/A, VXE2/A
	87521-ZE3-W03	.....	1	-	-	-----	VWE
			1	-	-	3663826	HA2/A, LX2/A, QAE2/A, QAP2/A, QA2/A, QNE2/A, QNE9/A, QXC9/A, VA2/A, VH12/A, VXE2/A
			1	-	-	3663826	LX/A, QXC/A, VXE/A
	87521-ZE3-W04	EMBLEM (GX340) .....	1	-	-	4072395	LX/A, QXC/A, VXE/A
2	87522-ZE1-810	MARK, CAUTION .....	1	-	-	2302949	HA, HAQ, LX, QA, QAE, QAP, QAPE, QAQ, QNE, QNE9, QXC, SXP, VA, VXE
3	87522-ZH8-W41	MARK, CAUTION (PICTOGRAPH) ..	1	-	-	-----	VWE
			1	-	-	3930788	QAE2/A, QAP2/A, QA2/A, QNE2/A, QXC9/A
	87522-ZH9-000	LABEL, CAUTION (ENGLISH, ETC.)	1	-	-	-----	HA, HAQ, HA2, HA2/A, HX2, LX, LX/A, LX2, LX2/A, QA, QAE, QAE2, QAP, QAPE, QAP2, QAQ, QA2, QH2, QNE, QNE2, QNE9, QNE9/A, QN18, QPE2, QXC, QXC/A, QXC9, QXE2, QX2, SXP, VA, VA2, VA2/A, VDE, VH12, VH12/A, VXE, VXE/A, VXE2, VXE2/A
			1	-	-	3930787	QAE2/A, QAP2/A, QA2/A, QNE2/A, QXC9/A
	87522-ZH9-010	.....	1	-	-	-----	VWE
			1	-	-	3930788	QAE2/A, QAP2/A, QA2/A, QNE2/A, QXC9/A
4	87528-ZE2-810	MARK, CHOKE (ORANGE) .....	1	-	-	-----	HA, HAQ, HA2, HA2/A, HX2, LX, LX/A, LX2, LX2/A, QA, QAE, QAE2, QAE2/A, QAP, QAPE, QAP2, QAP2/A, QAQ, QA2, QA2/A, QH2, QNE, QNE2, QNE2/A, QNE9, QNE9/A, QN18, QPE2, QXC, QXC/A, QXC9, QXC9/A, QXE2, QX2, SXP, VA, VAH1, VAH2, VAW1, VA2, VA2/A, VDE, VH12, VH12/A, VWA, VXA, VXE, VXE/A, VXE2, VXE2/A
	87528-ZH7-000	MARK, CHOKE (GRAY) .....	1	-	-	3930788	QAE2/A, QAP2/A, QA2/A, QNE2/A, QXC9/A

Ref. No.	Part No.	Description	Reqd. QTY			Serial No.	Parts catalogue code
			(1)	(2)	(3)		
5	87530-ZE3-W10	LABEL, SPECIFICATION (EXTERNAL)	1	-	-	-----	VWA
			1	-	-	-----	2205609 HA,HAQ,LX,QA,QAE,QAP,QAPE,QAQ,QNE,QNE9,QXC,SXP,VA,VAH1,VAH2,VXA VXE
6	87532-ZB4-G60	MARK, OIL ALERT (GERMAN) ....	1	-	-	-----	LX/A,QNE9/A,QN18,QXC/A,QXC9,QXC9/A,VAW1,VDE,VXE/A
	87532-ZB4-H50	MARK, OIL ALERT (FRENCH) ....	1	-	-	-----	2215598 HA,HAQ,LX,QA,QAE,QAP,QAPE,QAQ,QNE,QNE9,QXC,SXP,VA,VXA,VXE
			1	-	-	-----	LX/A,QNE9/A,QN18,QXC/A,QXC9,QXC9/A,VAW1,VDE,VXE/A
			1	-	-	-----	2215598 HA,HAQ,LX,QA,QAE,QAP,QAPE,QAQ,QNE,QNE9,QXC,SXP,VA,VXA,VXE
7	87532-ZE1-810	MARK, OIL ALERT (EXTERNAL) ..	1	-	-	-----	2143683 HA,LX,QA,QAP,QXC,SXP,VA,VAH1,VXA
8	87532-ZH8-810	MARK, OIL ALERT (EXTERNAL) ..	1	-	-	-----	HAQ,HA2,HA2/A,HX2,LX/A,LX2,LX2/A,QAE2,QAP2,QAQ,QA2,QNE2,QNE9 QNE9/A,QN18,QPE2,QXC/A,QXC9,QXE2,QX2,VAW1,VA2,VA2/A,VDE,VWE,VXE/A VXE2,VXE2/A
			1	-	-	-----	2143684 HA,LX,QA,QAE,QAP,QAPE,QNE,QXC,SXP,VA,VXA,VXE
			1	-	-	-----	3930787 QAE2/A,QAP2/A,QA2/A,QNE2/A,QXC9/A
9	87534-ZE1-841	LABEL, AIR CLEANER CAUTION ..	1	-	-	-----	QXC,QXC/A,QXC9,QXC9/A
10	87535-ZE1-840	MARK, AIR CLEANER SALES POINT	1	-	-	-----	QXC,QXC9
			1	-	-	-----	3670223 QXC/A,QXC9/A
	87535-ZE1-841	.....	1	-	-	-----	3670224 QXC/A,QXC9/A
11	89218-ZE1-000	WRENCH COMP., SPARK PLUG ....	1	-	-	-----	HA,HAQ,HA2,HA2/A,QA,QAE,QAE2,QAE2/A,QAP,QAPE,QAP2,QAP2/A,QAQ,QA2 QA2/A,QNE,QNE2,QNE2/A,QNE9,QNE9/A,QPE2,VA,VA2,VA2/A,VDE
			(1)	-	-	-----	QN18,VAW1
12	87135-ZE2-000	LABEL, E-SPEC (HONDA) (EPA STANDARD)(15.5X60.0)	1	-	-	-----	3334264 3461747 LX,QXC,VXE
	87135-ZE2-010	LABEL, E-SPEC (EPA STANDARD) (15.5X60.0)	1	-	-	-----	3461748 LX,QXC,VXE
	87135-ZE2-020	LABEL, E-SPEC (15.5X27.5) ...	1	-	-	-----	3989217 LX/A,QXC/A,VXE/A
13	87586-ZH7-W00	LABEL, FUEL CAUTION .....	1	-	-	-----	HAQ,QAQ,QNE9,QNE9/A
14	87532-ZH8-W40	MARK, THROTTLE INDICATION ...	1	-	-	-----	3930681 QAE2/A,QAP2/A,QA2/A,QNE2/A,QXC9/A
15	87522-883-660	MARK, CAUTION (ENGLISH/FRENCH/SPANISH)	1	-	-	-----	VWE
16	87528-898-620	MARK, CHOKE .....	1	-	-	-----	VWE
17	87533-ZC0-630	MARK, AIR CLEANER .....	1	-	-	-----	VWE
18	87539-898-620	MARK, EX. CAUTION (ENGLISH/FRENCH)	1	-	-	-----	VWE
19	87594-ZB4-A00	MARK, OIL CAUTION .....	1	-	-	-----	VWE



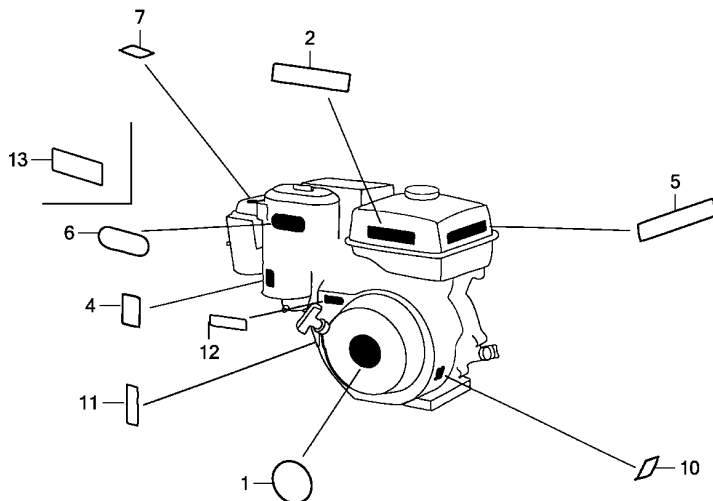

ZK30E2804C

Ref. L.O.N. (Relative ref. Number) F.R.T.  
No. Description

NO INFORMATION .....

Ref. No.	Part No.	Description	Reqd. QTY			Serial No.	Parts catalogue code
			(1)	(2)	(3)		
1	87521-ZE3-W02	EMBLEM (GX340 HONDA 11.0) ...	1	-	-	-----	EDE2,EDN2,LXE2,PKT2,QDW9,QMT2,QNR2,QTC2,SME2,SMX2,SXE2,VAD2,VDE2,VH22,VWA2,VWE2,VW12
			1	-	-	3658029	PKX2
			1	-	-	3663825	EDE2/A,EDN2/A,LXE2/A,PKT2/A,QDW9/A,QMT2/A,QNR2/A,QTC2/A,SMX2/A,VAD2/A,VDE2/A,VH22/A,VWE2/A,VW12/A
	87521-ZE3-W03	.....	1	-	-	3658030	PKX2
			1	-	-	3663826	EDE2/A,EDN2/A,LXE2/A,PKT2/A,QDW9/A,QMT2/A,QNR2/A,QTC2/A,SMX2/A,VAD2/A,VDE2/A,VH22/A,VWE2/A,VW12/A
2	87522-ZH9-010	LABEL, CAUTION (ENGLISH, ETC.)	1	-	-	-----	LXE2,LXE2/A,PKT2,PKT2/A,PKX2,QDW9,QDW9/A,QMT2,QMT2/A,QNR2,QNR2/A,QTC2,QTC2/A,SME2,SMX2,SMX2/A,SXE2,VAD2,VAD2/A,VDE2,VDE2/A,QDW9/A
	87522-ZH8-W41	MARK, CAUTION (PICTOGRAPH) ..	1	-	-	3930788	-----
4	87528-ZE2-810	MARK, CHOKE (ORANGE) .....	1	-	-	-----	LXE2,LXE2/A,PKT2,PKT2/A,PKX2,QDW9,QDW9/A,QMT2,QMT2/A,QNR2,QNR2/A,QTC2,QTC2/A,SME2,SMX2,SMX2/A,SXE2,VAD2,VAD2/A,VDE2,VDE2/A,VH22,VH22/A,VWA2,VWE2,VWE2/A,VW12,VW12/A
	87528-ZH7-000	MARK, CHOKE (GRAY) .....	1	-	-	3930788	-----
	87528-898-620	MARK, CHOKE .....	1	-	-	-----	EDE2,EDE2/A,EDN2,EDN2/A
5	87532-ZB4-G60	MARK, OIL ALERT (GERMAN) ....	1	-	-	-----	LXE2,LXE2/A,PKT2,PKT2/A,QDW9,QDW9/A,QMT2,QMT2/A,QNR2,QNR2/A,QTC2,QTC2/A,SME2,SMX2,SMX2/A,SXE2,VAD2,VAD2/A,VDE2,VDE2/A,VW12,VW12/A
	87532-ZB4-H50	MARK, OIL ALERT (FRENCH) ....	1	-	-	-----	LXE2,LXE2/A,PKT2,PKT2/A,QDW9,QDW9/A,QMT2,QMT2/A,QNR2,QNR2/A,QTC2,QTC2/A,SME2,SMX2,SMX2/A,SXE2,VAD2,VAD2/A,VDE2,VDE2/A,VW12,VW12/A
	87532-ZH8-810	MARK, OIL ALERT (EXTERNAL) ..	1	-	-	-----	LXE2,LXE2/A,PKT2,PKT2/A,PKX2,QDW9,QMT2,QMT2/A,QNR2,QNR2/A,QTC2,QTC2/A,SME2,SMX2,SMX2/A,SXE2,VAD2,VAD2/A,VDE2,VDE2/A,VWE2,VWE2/A,VW12,VW12/A
			1	-	-	3930787	QDW9/A
6	87535-ZE1-840	MARK, AIR CLEANER SALES POINT	1	-	-	-----	QDW9
			1	-	-	3600223	QDW9/A
	87535-ZE1-841	.....	1	-	-	3600224	QDW9/A
7	87534-ZE1-841	LABEL, AIR CLEANER CAUTION ..	1	-	-	-----	QDW9,QDW9/A

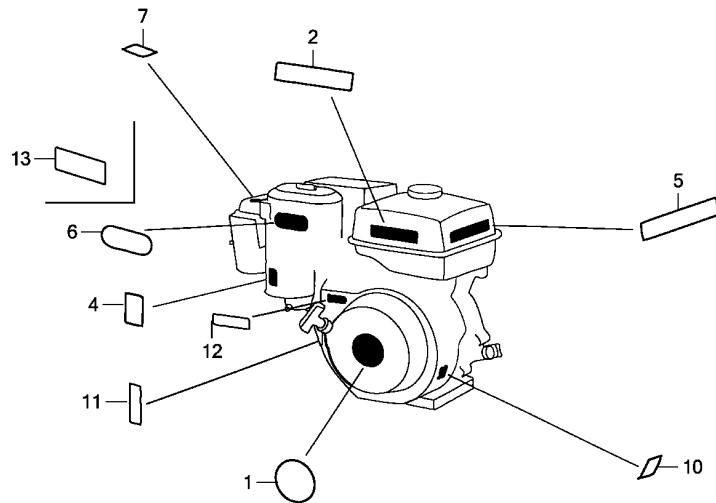

ZK30E2804C

Ref. No.	Part No.	Description	Reqd. QTY			Serial No.	Parts catalogue code
			(1)	(2)	(3)		
10	87594-ZB4-A00	MARK, OIL CAUTION .....	1	-	-	-----	EDE2,EDE2/A,EDN2,EDN2/A
11	87135-ZE2-000	LABEL, E-SPEC (HONDA) (EPA STANDARD)(15.5X60.0)	1	-	-	3334264 3461747	QMT2
	87135-ZE2-010	LABEL, E-SPEC (EPA STANDARD) (15.5X60.0)	1	-	-	-----	QMT2/A
			1	-	-	3461748	QMT2
12	87532-ZH8-W40	MARK, THROTTLE INDICATION ...	1	-	-	3930681	QDW9/A
13	87533-ZC0-630	MARK, AIR CLEANER .....	1	-	-	-----	EDE2,EDE2/A,EDN2,EDN2/A



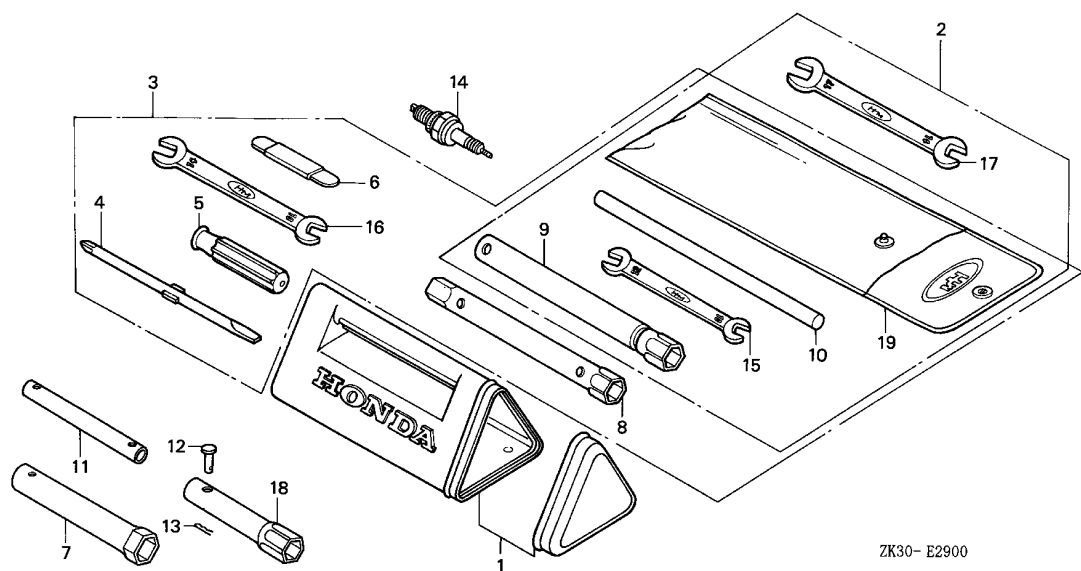

Ref. L.O.N. (Relative ref. Number) F.R.T.  
No. Description

NO INFORMATION .....

Ref. No.	Part No.	Description	Reqd. QTY			Serial No.	Parts catalogue code
			GX 340K1 (1)	(2)	(3)		
1	83501-ZF1-000	BOX, TOOL .....	1	-	-	LT,LT/A,QHB3,QHB3/A,QT,QT/A,SWX,SWX/A	
2	89000-ZE1-000	TOOL KIT .....	1	-	-	2667055 QP	
			1	-	-	2667056	EDN,LHW,QHP1,QHP1/A,QMH,QMH/A,QP/A,VMX QP
3	89001-ZF1-000	BAG SET, TOOL .....	1	(1)	-	LT,LT/A,QHB3,QHB3/A,QT,QT/A,SWX,SWX/A	
			1	-	-	2667055	QP
4	89102-538-000	DRIVER, SCREW (NO.2 + -) ....	1	-	-	LT,LT/A,QHB3,QHB3/A,QT,QT/A,SWX,SWX/A	
			1	-	-	2667055	QP
5	89103-538-000	GRIP .....	1	-	-	LT,LT/A,QHB3,QHB3/A,QT,QT/A,SWX,SWX/A	
			1	-	-	2667055	QP
6	89210-ZF1-000	GAUGE ASSY., THICKNESS .....	1	-	-	LT,LT/A,QHB3,QHB3/A,QT,QT/A,SWX,SWX/A	
			1	-	-	2667055	QP
7	89216-ZB4-000	WRENCH, PLUG .....	1	-	-	EDS,EDS1,EDS1/A,EDS2,EDS2/A,EDS4,EDS6,EDS6/A,EDT,EDT/A,EDT1 EDT1/A,EDT2,EDT3,EDT6,EDT6/A,ED6,ED6/A,ENT,ENT/A,EN6,EN6/A,ES3 ES3/A,ES4,ES4/A,VC2,VC2/A,VMQ,VMT,VMT/A,VS2,VS3,VS4,VS5,VS6,VS7 VTE2	
8	89216-ZF1-000	WRENCH, BOX .....	1	-	-	LT,LT/A,QHB3,QHB3/A,QT,QT/A,SWX,SWX/A	
			1	-	-	2667055	QP
9	89218-ZE1-000	WRENCH COMP., SPARK PLUG ....	1	-	-	EDK,EDN,EDN5,EDN5/A,ED7,ED8,ED8/A,ED9,ED9/A,EN,ES,ES1,ES1/A,ES2 ET,ETS,ETX,LHW,LP,LT,LT/A,PKT4,PKT4/A,PKX4,PKX4/A,QAB2,QAB2/A QAC2,QAC2/A,QAE6,QAE6/A,QA2,QA2/A,QA26,QA26/A,QE,QE/A,QHB3 QHB3/A,QHP1,QHP1/A,QKA4,QKA4/A,QME8,QME8/A,QMH,QMH/A,QMX2,QNE6,QP QP/A,QT,QT/A,SE,SE/A,SHT,SWX,SWX/A,VMX,VNG,VNG1,VNG2	
			(1)	-	-	PXA2,QL2,QNR6,QNR6/A	
			-	(1)	-		

Ref. No.	Part No.	Description	Reqd. QTY			Serial No.	Parts catalogue code
			(1)	(2)	(3)		
10	89219-805-000	HANDLE, BOX WRENCH .....	1	-	-	-----	EDN,LHW,LT,LT/A,QHB3,QHB3/A,QHP1,QHP1/A,QMH,QMH/A,QP,QP/A,QT,QT/A SWX,SWX/A,VMX
			-	(1)	-		
11	89220-ZE2-000	PIPE, BOX WRENCH EXTENSION ..	-	(1)	-		
12	90755-758-L00	PIN, ROLLER ARM, 8X22 .....	-	(1)	-		
13	94252-08000	PIN, LOCK, 8MM .....	-	(1)	-		
14	98079-55846	PLUG, SPARK (BPR5ES)(NGK) ...	1	-	-	-----	VS2,VS7
	98079-56841	PLUG, SPARK (BP6ES)(NGK) ....	1	-	-	-----	3032023 QHB3
	98079-56854	PLUG, SPARK (W20EP-U)(DENSO)	1	-	-	-----	LP
			1	-	-	-----	2085033 QT
			-	(1)	-		
	98079-56855	PLUG, SPARK (W20EPR-U)(DENSO)	1	-	-	-----	HX26,HX26/A,LHW,LXE6,LX26,LX26/A,QAE6,QAE6/A,QA26,QA26/A,QHP1 QHP1/A,QNE6,QNR6,QNR6/A,QXC6,QXC6/A,QXE6,QXE6/A,SWX,SWX/A,VD16 VEB6,VXE6,VXK,VX16,VX16/A
			-	(1)	-		
	98079-56846	PLUG, SPARK (BPR6ES)(NGK) ...	1	-	-	-----	ED8,ED8/A,ED9,ED9/A,ES2,HX26,HX26/A,LHW,LXE6,LX26,LX26/A,PKX2 QAE6,QAE6/A,QA26,QA26/A,QHP1,QHP1/A,QNE6,QNR6,QNR6/A,QXC6,QXC6/A QXE6,QXE6/A,SWX,SWX/A,VD16,VEB6,VX,VX/A,VXB2,VXE6,VXK,VX16,VX16/A
			(1)	-	-	-----	QHB3/A
			(1)	-	-	-----	3032024 QHB3
			-	(1)	-		
15	99001-10120	SPANNER, 10X12 .....	1	-	-	-----	EDN,LHW,LT,LT/A,QHB3,QHB3/A,QHP1,QHP1/A,QMH,QMH/A,QP,QP/A,QT,QT/A SWX,SWX/A,VMX
			-	(1)	-		
16	99001-10140	SPANNER, 10X14 .....	1	-	-	-----	LT,LT/A,QHB3,QHB3/A,QT,QT/A,SWX,SWX/A
			1	-	-	-----	2667055 QP
17	99001-14170	SPANNER, 14X17 .....	1	-	-	-----	EDN,LHW,QHP1,QHP1/A,QMH,QMH/A,VMX
			-	(1)	-		
18	99004-21003	WRENCH, BOX (P21) .....	-	(1)	-		
19	99008-02300	BAG, TOOL, 230MM .....	1	-	-	-----	EDN,LHW,LT,LT/A,QHB3,QHB3/A,QHP1,QHP1/A,QMH,QMH/A,QP,QP/A,QT,QT/A SWX,SWX/A,VMX
			-	(1)	-		



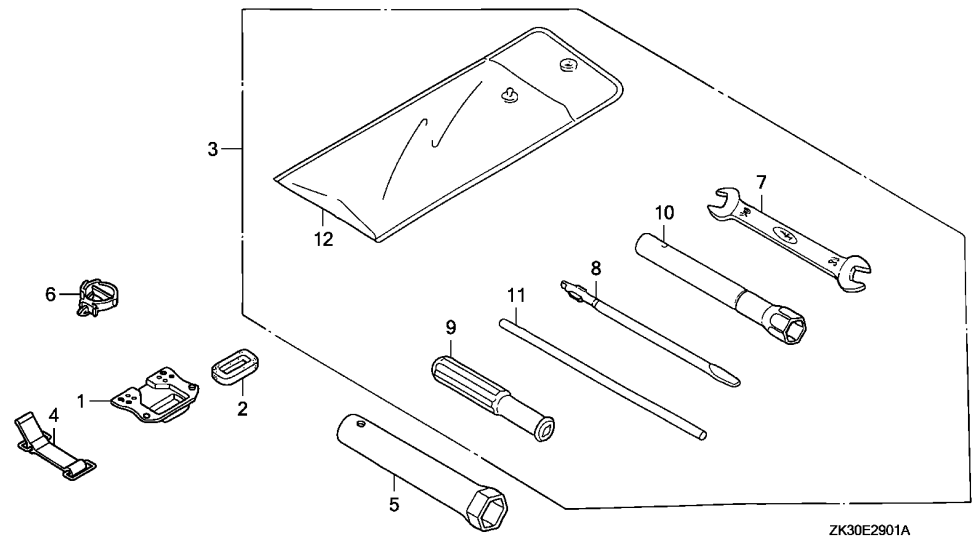

ZK30E2901A

Ref. No.	L.O.N.	(Relative ref. Number)	Description	F.R.T.
----------	--------	------------------------	-------------	--------

NO INFORMATION .....

Ref. No.	Part No.	Description	Reqd. QTY			Serial No.	Parts catalogue code
			GX	340K1			
			(1)	(2)	(3)		
1	68310-ZB7-000	GUIDE, UNDER AIR .....	1	-	-	-----	EDS5
2	68312-ZB7-000	SEAL, UNDER AIR GUIDE .....	1	-	-	-----	EDS5
3	89000-ZB6-000	TOOL KIT .....	1	-	-	-----	EDS5,LHB5,QHB5
4	89011-192-700	BAND, TOOL SETTING .....	1	-	-	-----	EDS5
5	89216-ZB4-000	WRENCH, PLUG .....	1	-	-	-----	EDS3
6	90690-SA0-003	STRAP, WIRE HARNESS, 25MM (BLACK)	2	-	-	-----	EDS5
7	99001-10120	SPANNER, 10X12 .....	1	-	-	-----	EDS5,LHB5,QHB5
8	99003-30000	DRIVER MINUS SCREW 3,(NO.2)	1	-	-	-----	EDS5,LHB5,QHB5
9	99003-50000	GRIP, SCREW DRIVER .....	1	-	-	-----	EDS5,LHB5,QHB5
10	99004-21003	WRENCH, BOX (P21) .....	1	-	-	-----	EDS5,LHB5,QHB5
11	99005-01000	BAR A, HANDLE .....	1	-	-	-----	EDS5,LHB5,QHB5
12	99008-02000	BAG, TOOL, 200MM .....	1	-	-	-----	EDS5,LHB5,QHB5



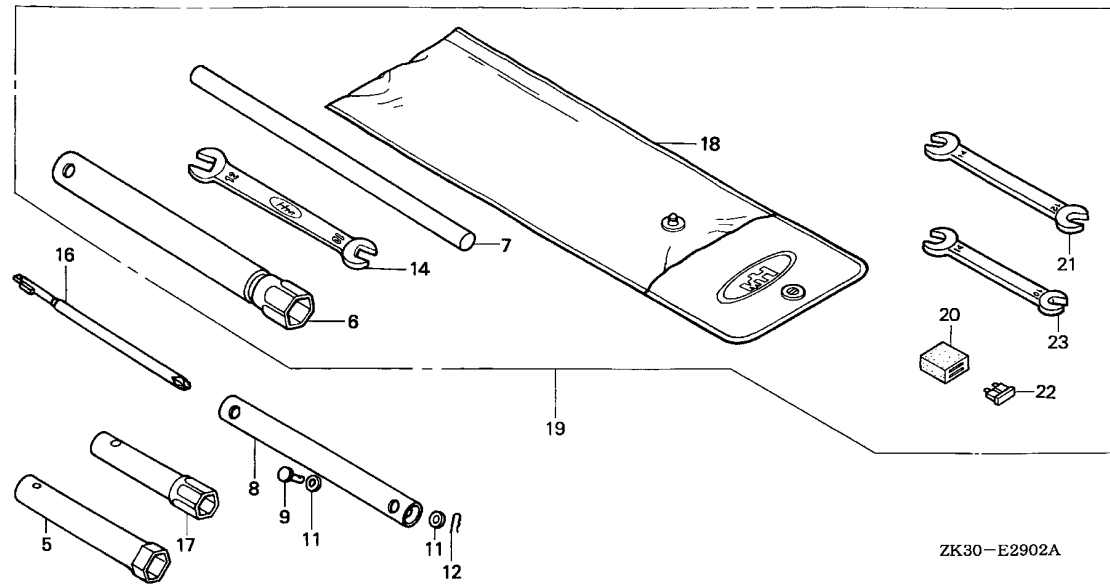

ZK30-E2902A

Ref. No. L.O.N. (Relative ref. Number) Description F.R.T.

NO INFORMATION .....

Ref. No.	Part No.	Description	Reqd. QTY			Serial No.	Parts catalogue code
			GX	340K1			
			(1)	(2)	(3)		
5	89216-ZB4-000	WRENCH, PLUG .....	1	-	-	-----	EDS1,EDS1/A,EDT1,EDT1/A
6	89218-ZE1-000	WRENCH COMP., SPARK PLUG ....	1	-	-	-----	BJ,LJ,LJ/A,LJG,LJG/A,LJS,LJS/A,LJS1,LSX,LWD,LWD1,LWD1/A,SDE,SJ SJ/A,SJG,SJG/A,SKE,SKE/A,SKZ,SKZ/A,STJ,STJ/A,STP,STP/A,STQ,STQ/A STR,STR/A,YJ
7	89219-805-000	HANDLE, BOX WRENCH .....	1	-	-	-----	LWD,LWD1,LWD1/A
8	89220-ZE3-L60	PIPE, BOX WRENCH EXTENSION ..	1	-	-	-----	ZK1,ZK1/A
9	90752-752-000	PIN, FLAT, 6X27.5 .....	1	-	-	-----	ZK1,ZK1/A
11	94101-06000	WASHER, PLAIN, 6MM .....	2	-	-	-----	ZK1,ZK1/A
12	94251-06000	PIN, LOCK, 6MM .....	1	-	-	-----	ZK1,ZK1/A
14	99001-10120	SPANNER, 10X12 .....	1	-	-	-----	LWD,LWD1,LWD1/A
16	99003-20000	DRIVER PLUS SCREW 2,(NO.3) ..	1	-	-	-----	ZK1,ZK1/A
17	99004-21003	WRENCH, BOX (P21) .....	1	-	-	-----	ZK1,ZK1/A
18	99008-02300	BAG, TOOL, 230MM .....	1	-	-	-----	LWD,LWD1,LWD1/A
19	89000-766-800	TOOL SET .....	1	-	-	-----	LWD,LWD1,LWD1/A
20	38306-KK4-000	SUSPENSION, WINKER RELAY (MITSUBA)	1	-	-	-----	LWD,LWD1,LWD1/A
21	89216-KB7-000	SPANNER, 12X14 .....	1	-	-	-----	LWD,LWD1,LWD1/A
22	98200-32000	FUSE, BLADE (20A) .....	2	-	-	-----	LWD,LWD1,LWD1/A
23	99001-10140	SPANNER, 10X14 .....	1	-	-	-----	LWD,LWD1,LWD1/A



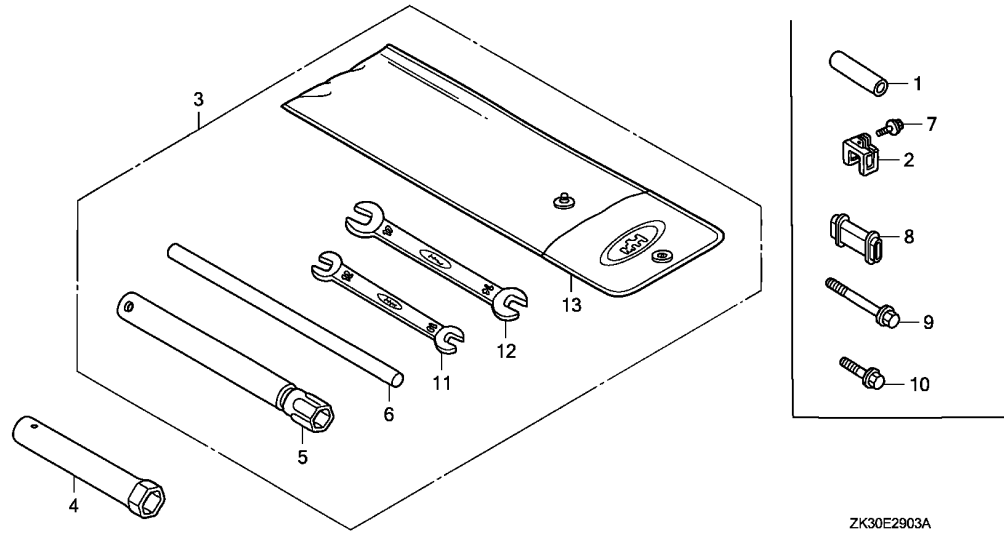

ZK30E2903A

Ref. L.O.N. (Relative ref. Number) F.R.T.  
No. Description

NO INFORMATION .....

2

Ref. No.	Part No.	Description	Reqd. QTY			Serial No.	Parts catalogue code
			GX	340K1			
			(1)	(2)	(3)		
1	18301-ZE2-V60	COLLAR, 10X16X53 .....	1	-	-	-----	ED6,ED6/A
2	30561-ZB4-000	CLIP, WIRE .....	1	-	-	3659637	ENT/A
3	89000-ZE1-000	TOOL KIT .....	1	-	-	2764578	ED6,ED6/A
4	89216-ZB4-000	WRENCH, PLUG .....	1	-	-	-----	EDE2,EDN2
5	89218-ZE1-000	WRENCH COMP., SPARK PLUG ....	1	-	-	-----	ED6,ED6/A
			1	-	-	2764578	PKT2,PKT2/A,PKX2,QTC2,QTC2/A,SME2,SMX2,SMX2/A
			(1)	-	-	-----	EDE2,EDN2
				-	-	-----	QNR2,QNR2/A,VDE2,VDE2/A,VW12,VW12/A
6	89219-805-000	HANDLE, BOX WRENCH .....	1	-	-	5165563	EDE2,EDN2
7	90013-883-000	BOLT, FLANGE, 6X12(CT200) ...	1	-	-	-----	ED6,ED6/A
			1	-	-	3659637	ENT/A
8	91406-ZB4-000	TUBE, CORD .....	1	-	-	-----	ED6,ED6/A
9	95701-08070-00	BOLT, FLANGE, 8X70 .....	1	-	-	-----	ED6,ED6/A
			1	-	-	3659637	ENT/A
10	95801-08020-18	BOLT, FLANGE, 8X20 .....	1	-	-	-----	ED6,ED6/A
11	99001-10120	SPANNER, 10X12 .....	1	-	-	2764578	EDE2,EDN2
12	99001-14170	SPANNER, 14X17 .....	1	-	-	2764578	EDE2,EDN2
13	99008-02300	BAG, TOOL, 230MM .....	1	-	-	2764578	EDE2,EDN2

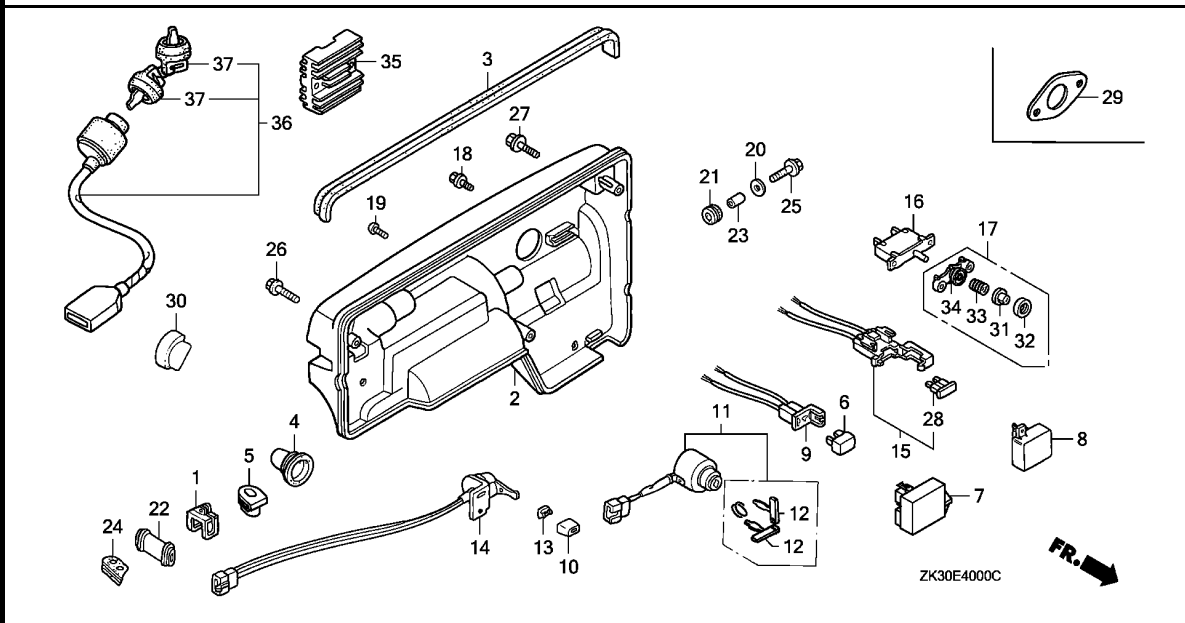

Ref. No.	L.O.N.	(Relative ref. Number) Description	F.R.T.
NO INFORMATION .....			

Ref. No.	Part No.	Description	Reqd. QTY			Serial No.	Parts catalogue code
			GX	340K1			
			(1)	(2)	(3)		
1	30561-ZB4-000	CLIP, WIRE .....	1	-	-	-----	EDS,EDS1,EDS1/A,EDS2,EDS2/A,EDS3,EDS4,EDS6,EDS6/A,EDT,EDT/A,EDT1,EDT1/A,EDT2,EDT6,EDT6/A,ED6,ED6/A,ENT,ENT/A,EN6,EN6/A,VTE2
2	31425-ZB4-010ZA	CASE, CONTROL *R8*.....BRIGHT RED	1	-	-	-----	EDS,ED6,ENT
	31425-ZB4-010ZB	*NH1*.....BLACK	1	-	-	-----	ED6/A,ENT/A
	31425-ZB4-010ZC	*T68*.....TSURUMI BLUE	1	-	-	-----	ENT,ENT/A
	31425-ZB4-010ZD	*R280*.....POWER RED	1	-	-	-----	EDT,EDT/A
3	31462-ZB4-000	RUBBER, CONTROL .....	1	-	-	-----	ED6/A,ENT/A
			1	-	-	-----	EDS,EDT,EDT/A
			1	-	-	-----	ED6
4	31482-ZB4-003	GROMMET, MAIN CORD .....	1	-	-	-----	EDS,EDT,EDT/A
			1	-	-	-----	ED6
5	31483-ZB4-003	GROMMET, SWITCH CORD .....	1	-	-	-----	EDS,EDT,EDT/A
			1	-	-	-----	ED6
6	31700-124-008	RECTIFIER ASSY., SILICON (SHINDENGEN)	1	-	-	-----	EDS,EDS1,EDS1/A,EDS2,EDS2/A,EDS4,EDS6,EDS6/A,EDT,EDT/A,ENT,ENT/A
			1	-	-	-----	ENT2
7	31710-ZB4-003	DIODE ASSY. ....	1	-	-	-----	EDS3
8	31710-ZB7-A01	DIODE ASSY. ....	1	-	-	-----	EDS5
9	32130-ZE1-000	COUPLER COMP. ....	1	-	-	-----	EDS,EDS1,EDS1/A,EDS2,EDS2/A,EDS4,EDS6,EDS6/A,EDT,EDT/A,ENT,ENT/A
			1	-	-	-----	ENT2
10	32343-892-003	KNOB, COCK LEVER .....	1	-	-	-----	EDT1,EDT1/A,EDT2,EDT6,EDT6/A
			1	-	-	-----	ED6
11	35100-ZB4-013	SWITCH ASSY., COMBINATION ...	1	-	-	-----	EDS,EDS1,EDS2,EDS2/A,EDS3,EDS6,EDS6/A,EDT,EDT/A,ENT,ENT/A,ENT2
			1	-	-	-----	ES4
			1	-	-	-----	EDS1/A,EDS4,ES4/A,VS5,VS6
	35100-ZA0-013	.....	1	-	-	-----	EDS5



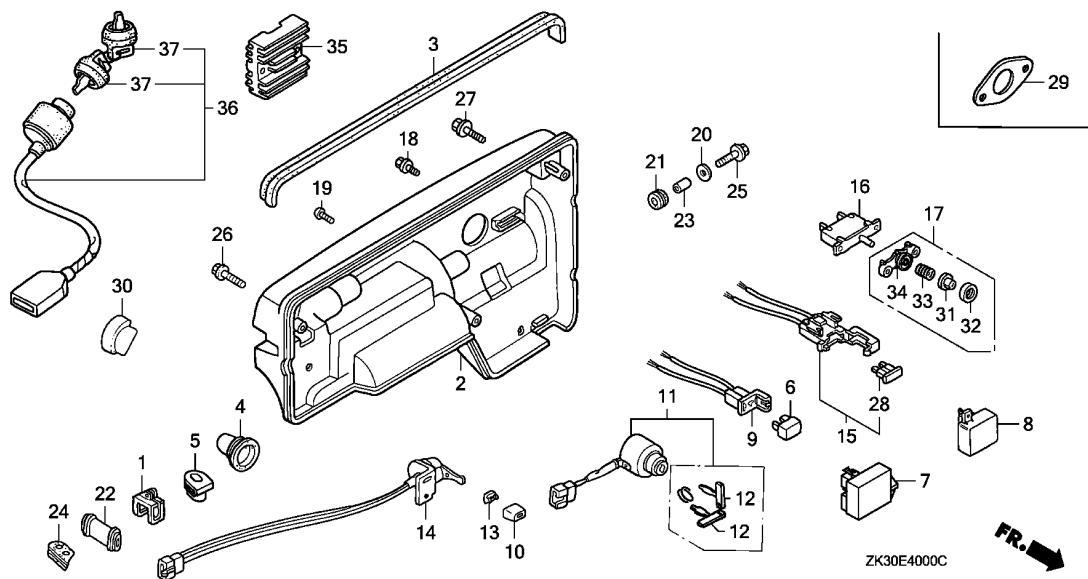

Ref. No.	Part No.	Description	Reqd. QTY			Serial No.	Parts catalogue code
			GX	340K1	(3)		
11)	35100-ZB4-023	SWITCH ASSY., COMBINATION ...	1	-	-	VS7	
12	35111-880-003	KEY COMP. ....	2	-	-	4074661	EDS1/A,EDS4,ES4/A,VS5,VS6
			2	-	-	3792398	EDS1,EDS2,EDS6,EDT,ENT,ES4
	35111-880-013	.....	2	-	-	3838382	EDS1/A,EDS2/A,EDS6/A,EDT/A,ENT/A,ENT2,ES4/A
			2	-	-		EDS,EDS3,EDS5
			2	-	-	3792399	EDS4,VS5,VS6,VS7
			2	-	-	3838383	EDS1/A,EDS2/A,EDS6/A,EDT/A,ENT/A,ENT2,ES4/A
13	36106-892-003	BUSH, CONTROL KNOB .....	1	-	-		EDS,EDS3,EDS5
			1	-	-	2392334	EDT1,EDT1/A,EDT2,EDT6,EDT6/A
14	36110-ZB4-701	SWITCH ASSY., ENGINE KILL ...	1	-	-		ED6
			1	-	-	2392334	EDT1,EDT2,EDT6,EDT6/A
	36110-ZB4-702	.....	1	-	-	4080332	ED6
15	38220-ZE1-000	CASE COMP., FUSE .....	1	-	-	4080333	EDT1/A
	38220-ZE2-R70	.....	1	-	-		EDS,EDS1,EDS1/A,EDS2,EDS2/A,EDS4,EDS6,EDS6/A,EDT,EDT/A
			1	-	-		EDS3,ENT,ENT/A,ENT2
16	38240-VA3-900	PROTECTOR, CIRCUIT (1.0A) ...	1	-	-		EDS,EDS1,EDS1/A,EDS2,EDS2/A,EDS3,EDS4,EDS5,EDT,EDT/A,VXE7,VXE7/A
	38240-ZE2-840	PROTECTOR, CIRCUIT (3.5A) ...	1	-	-		EDS6,EDS6/A,ENT,ENT/A
17	38250-898-000	LENS ASSY., PROTECTOR .....	1	-	-		EDS,EDS1,EDS1/A,EDS2,EDS2/A,EDS3,EDS4,EDS5,EDS6,EDS6/A,EDT,EDT/A
							ENT,ENT/A
18	90013-883-000	BOLT, FLANGE, 6X12(CT200) ...	1	-	-		ENT2,VTE2
19	90101-692-000	SCREW, GLOVE BOX .....	1	-	-		EDS,EDS1,EDS1/A,EDS2,EDS2/A,EDS3,EDS4,EDS6,EDS6/A,EDT,EDT/A,EDT1
						2160982	EDT1/A,EDT2,EDT3,EDT6,EDT6/A,ENT,ENT/A
20	90506-500-000	WASHER, AIR DUCT .....	1	-	-	2392334	ED6
			3	-	-		EDS,EDT,EDT/A,ENT,ENT/A
			3	-	-	2392334	ED6

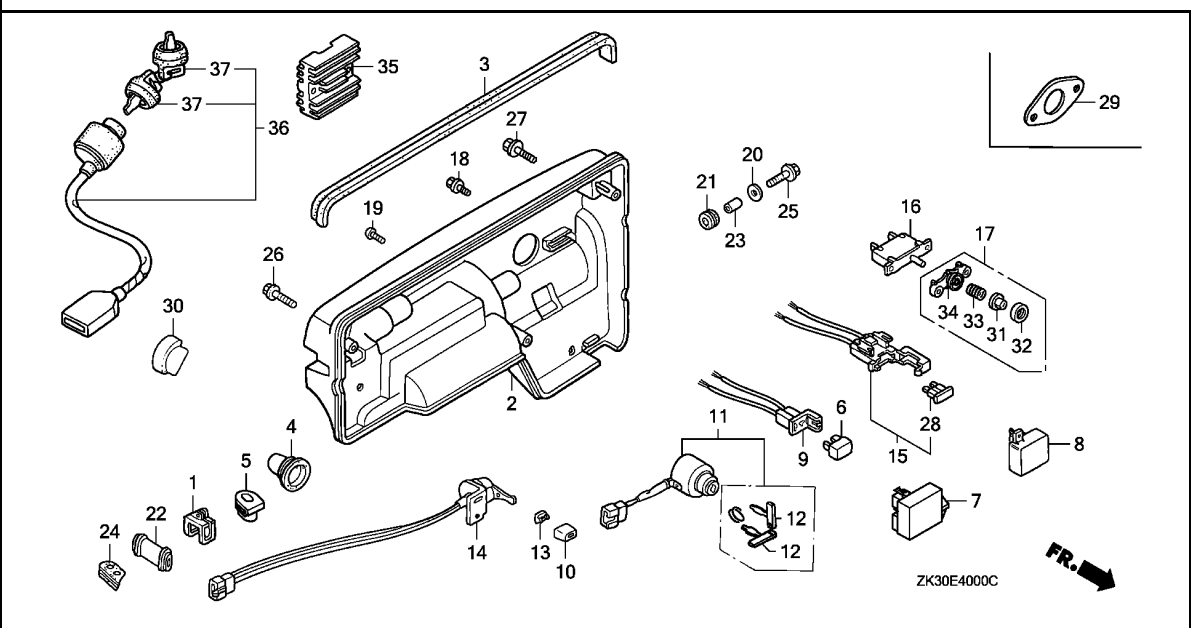

Ref. No.	Part No.	Description	Reqd. QTY			Serial No.	Parts catalogue code
			GX	(1)	(2)		
21	90852-898-000	RUBBER, CONTROL BOX .....	3	-	-	-----	EDS,EDT,EDT/A,ENT,ENT/A
22	91406-ZB4-000	TUBE, CORD .....	1	-	-	2392334	ED6
23	91552-898-000	COLLAR, CONTROL BOX .....	3	-	-	-----	EDS,EDT,EDT/A,ENT,ENT/A
24	91601-ZB4-003	GROMMET, TUBE .....	1	-	-	2392334	ED6
			1	-	-	2392334	ED6
25	95701-06018-00	BOLT, FLANGE, 6X18 .....	3	-	-	2392334	ED6
	95701-06020-00	BOLT, FLANGE, 6X20 .....	3	-	-	-----	EDS,EDT,EDT/A,ENT,ENT/A
26	95701-06040-08	BOLT, FLANGE, 6X40 .....	3	-	-	-----	EDS,EDT,EDT/A,ENT,ENT/A
			3	-	-	2160982 2392334	ED6
27	95801-08020-18	BOLT, FLANGE, 8X20 .....	1	-	-	-----	ED6/A,EN6,EN6/A,VTE2
			1	-	-	2392335	ED6
28	98200-30500	FUSE, BLADE (5A) .....	1	-	-	-----	EDS,EDS1,EDS1/A,EDS2,EDS2/A,EDS4,EDS6,EDS6/A,EDT,EDT/A
	98200-31000	FUSE, BLADE (10A) .....	1	-	-	-----	EDS3,ENT,ENT/A,ENT2
29	18333-ZE3-800	GASKET, EX. PIPE .....	1	-	-	-----	EDS4,EDS5,VS4,VS6
30	90855-ZB4-000	GROMMET, CRANKCASE .....	1	-	-	-----	EMT,EMT/A,VMQ,VMT,VMT/A
31	38251-898-000	LENS .....	1	-	-	-----	EDS2,EDS2/A,EDS4,EDT,EDT/A,ENT,ENT/A
32	38252-898-000	CAP, LENS .....	1	-	-	-----	EDS2,EDS2/A,EDS4,EDT,EDT/A,ENT,ENT/A
33	38253-898-000	SPRING, COIL .....	1	-	-	-----	EDS2,EDS2/A,EDS4,EDT,EDT/A,ENT,ENT/A
34	38254-898-000	HOLDER, LENS .....	1	-	-	-----	EDS2,EDS2/A,EDS4,EDT,EDT/A,ENT,ENT/A
35	31620-762-003	RECTIFIER COMP., REGULATOR ..	1	-	-	-----	LWD
36	35100-768-S01	SWITCH ASSY., COMBINATION ...	1	-	-	-----	LWD
37	35110-766-003	KEY ASSY., COMBINATION SWITCH	2	-	-	3826797	LWD
	35110-736-612	.....	2	-	-	3826798	LWD

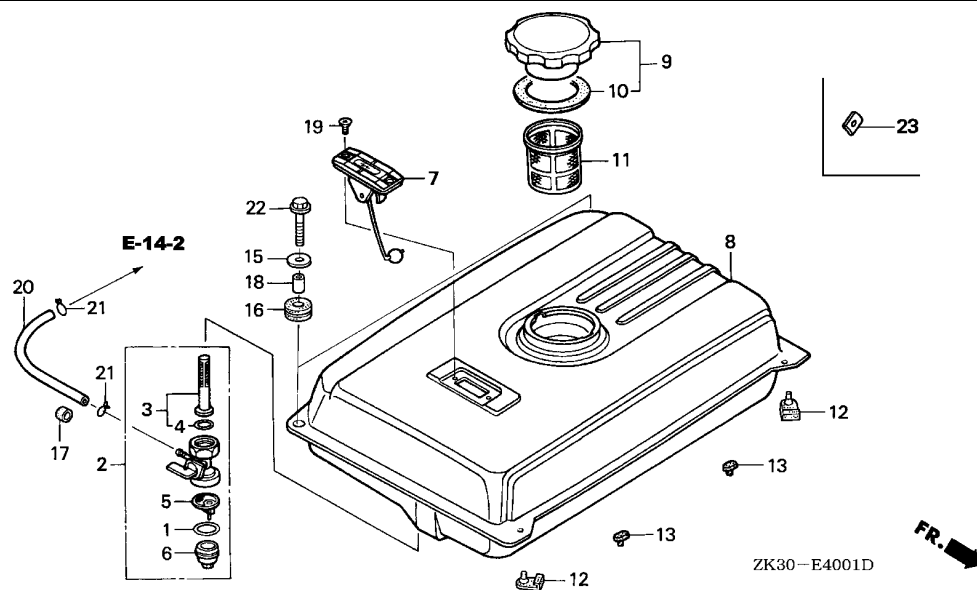

Ref. No.	L.O.N.	(Relative ref. Number) Description	F.R.T.
2	3101A3	COCK, FUEL .....	0.2
3	3101D5	SCREEN, FUEL STRAINER .....	0.2
5		(1)	
	3101A7	FILTER, FUEL TANK CUP .....	0.2
7	6171A1	METER/GAUGE UNIT, FUEL .....	0.1
8	3101D0	TANK, FUEL(A) .....	0.3
11	3101A6	FILTER, FUEL .....	0.1
20	3101F2	TUBE, FUEL COCK .....	0.2

Ref. No.	Part No.	Description	Reqd. QTY			Serial No.	Parts catalogue code
			GX	(1)	(2)		
1	16173-001-004	PACKING, FUEL STRAINER CUP ..	1	-	-	EDK,EDS4,EDT,EDT/A,EDT3,ENT,ENT/A,ES2,VS2,VS3,VS4,VS5,VS6,VS7,VXK	
2	16950-ZB4-015	COCK ASSY., FUEL .....	1	-	-	EDS4,EDT,EDT/A,EDT3,ENT,ENT/A,VS2,VS3,VS4,VS5,VS6,VS7	
3	16952-ZB4-005	SCREEN, FUEL STRAINER .....	1	-	-	EDS4,EDT,EDT/A,EDT3,ENT,ENT/A,VS2,VS3,VS4,VS5,VS6,VS7	
4	16958-397-771	O-RING .....	1	-	-	EDS4,EDT,EDT/A,EDT3,ENT,ENT/A,VS2,VS3,VS4,VS5,VS6,VS7	
5	16959-471-831	FILTER, CUP .....	1	-	-	EDS4,EDT,EDT/A,EDT3,ENT,ENT/A,VS2,VS3,VS4,VS5,VS6,VS7	
6	16967-GA6-671	CUP, FUEL STRAINER .....	1	-	-	EDS4,EDT,EDT/A,EDT3,ENT,ENT/A,VS2,VS3,VS4,VS5,VS6,VS7	
7	17505-ZB2-003	METER ASSY., FUEL .....	1	-	-	EDT,EDT/A,ENT,ENT/A,VS2,VS3,VS4,VS5,VS6,VS7	
8	17510-ZB4-000ZA	TANK COMP., FUEL	1	-	-	ENT,ENT/A	
	17510-ZB4-000ZB	*NH31*.....MCKINLEY WHITE	1	-	-	ENT	
		*R8*.....BRIGHT RED	1	-	3724082	ENT/A	
	17510-ZB4-000ZC	*NH1*.....BLACK	1	-	-	ENT,ENT/A	
	17510-ZB4-000ZE	*T68*.....TSURUMI BLUE	1	-	-	EDT,EDT/A	
	17510-ZB4-000ZF	*Y131*.....LIGHTNING YELLOW	1	-	-	ENT,ENT/A	
	17510-ZB4-000ZH	*R280*.....POWER RED	1	-	3724083	ENT/A	
9	17620-899-013	CAP COMP., FUEL FILLER .....	1	-	-	EDT,EDT/A,ENT,ENT/A,VS2,VS3,VS4,VS5,VS6,VS7	
10	17631-899-000	PACKING, FUEL FILLER CAP .....	1	-	-	EDT,EDT/A,ENT,ENT/A,VS2,VS3,VS4,VS5,VS6,VS7	
11	17670-899-000	FILTER COMP., FUEL .....	1	-	-	EDT,EDT/A,ENT,ENT/A,VS2,VS3,VS4,VS5,VS6,VS7	
12	50319-ZB2-000	RUBBER, TANK MOUNTING .....	2	-	-	EDS4,EDT,EDT/A,EDT3,ENT,ENT/A	
13	76122-952-000	STOPPER, DISCHARGE GUARD .....	2	-	-	EDT,EDT/A,ENT,ENT/A	
			4	-	-	VS2,VS3,VS4,VS5,VS6,VS7	
15	90503-898-000	WASHER, TANK CUSHION .....	2	-	-	EDT,EDT/A,ENT,ENT/A	
			4	-	-	VS2,VS3,VS4,VS5,VS6,VS7	
16	90851-898-000	RUBBER, TANK CUSHION .....	2	-	-	EDT,EDT/A,ENT,ENT/A	
			4	-	-	VS2,VS3,VS4,VS5,VS6,VS7	
17	90854-ZB2-000	RUBBER, FUEL (9X15X10) .....	1	-	-	EDT,EDT/A,EDT3,ENT,ENT/A,VS3,VS5	

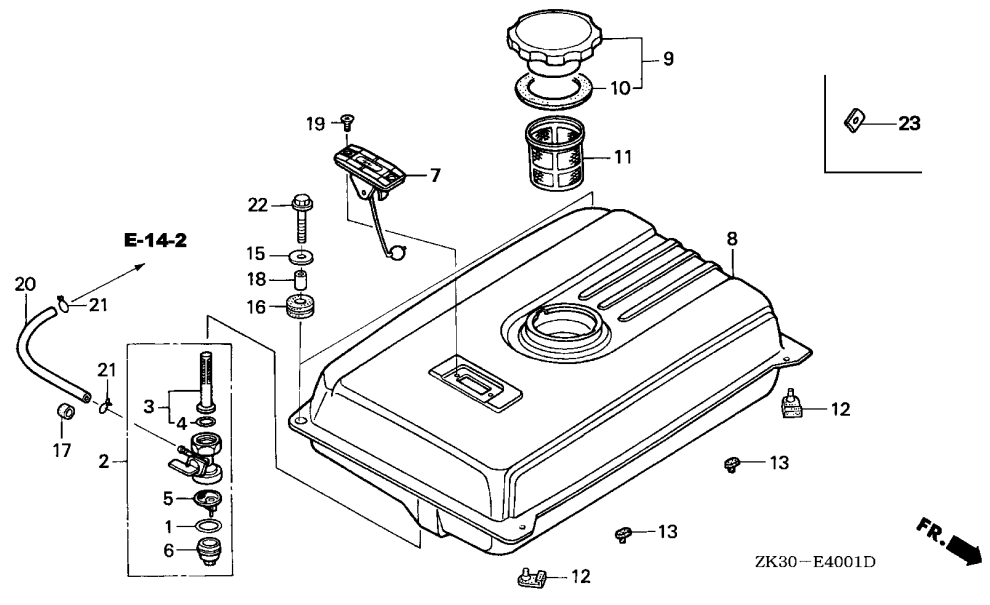

Ref. No.	Part No.	Description	Reqd. QTY			Serial No.	Parts catalogue code
			GX 340K1 (1)	(2)	(3)		
18	91551-898-000	COLLAR, TANK CUSHION .....	2	-	-	EDT,EDT/A,ENT,ENT/A	
19	93600-05010-0A	SCREW, FLAT, 5X10 .....	4	-	-	VS2,VS3,VS4,VS5,VS6,VS7	
20	95001-45150-40	TUBE, FUEL, 4.5X150 (95001-45001-60M)	1	-	-	EDT,EDT/A,ENT,VS3,VS5	
	95001-45165	TUBE, FUEL, 4.5X165 (95001-45001-60M)	1	-	-	3659636 ENT/A	
	95001-45190-40	TUBE, FUEL, 4.5X190 (95001-45001-60M)	1	-	-	EDT3	
			1	-	-	3659637 ENT/A	
21	95002-02080	CLIP, TUBE (B8) .....	2	-	-	EDT,EDT/A,EDT3,ENT,ENT/A,VS3,VS5	
22	95701-06022-00	BOLT, FLANGE, 6X22 .....	2	-	-	EDT,EDT/A,ENT,ENT/A	
23	90501-898-000	WASHER, FRAME JOINT .....	8	-	-	VS5,VS6,VS7	



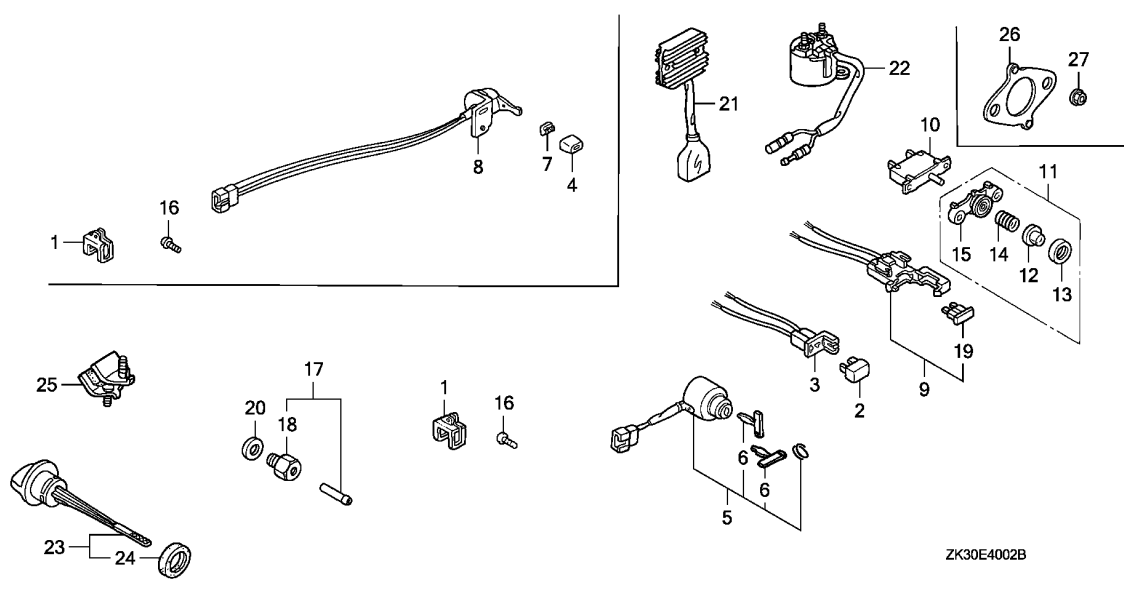

Ref. No.	L.O.N.	(Relative ref. Number) Description	F.R.T.
----------	--------	------------------------------------	--------

NO INFORMATION .....

ZK30E4002B

Ref. No.	Part No.	Description	Reqd. QTY			Serial No.	Parts catalogue code
			GX	340K1	(3)		
1	30561-ZB4-000	CLIP, WIRE .....	1	-	-	-----	EDS1,EDS1/A,EDT1,EDT1/A,EDT3
2	31700-124-008	RECTIFIER ASSY., SILICON (SHINDENGEN)	1	-	-	-----	EDS1,EDS1/A,VWE
3	32130-ZE1-000	COUPLER COMP. ....	1	-	-	-----	EDS1,EDS1/A
4	32343-892-003	KNOB, COCK LEVER .....	1	-	-	-----	EDT1,EDT1/A,EDT3
5	35100-ZB4-013	SWITCH ASSY., COMBINATION .....	1	-	-	-----	EDS1,EDS1/A
	35100-766-013	.....	1	-	-	-----	LWD1,LWD1/A
6	35111-880-003	KEY COMP. ....	2	-	-	-----	EDS1
			2	-	-	3792398	EDS1/A
	35110-766-003	KEY ASSY., COMBINATION SWITCH	2	-	-	-----	LWD1
			2	-	-	3826797	LWD1/A
	35111-880-013	KEY COMP. ....	2	-	-	3792399	EDS1/A
	35110-736-612	KEY ASSY., COMBINATION SWITCH	2	-	-	3826798	LWD1/A
7	36106-892-003	BUSH, CONTROL KNOB .....	1	-	-	-----	EDT1,EDT1/A,EDT3
8	36110-ZB4-701	SWITCH ASSY., ENGINE KILL ...	1	-	-	-----	EDT1
			1	-	-	4080332	EDT1/A
	36110-ZB4-702	.....	1	-	-	-----	EDT3
			1	-	-	4080333	EDT1/A
9	38220-ZE1-000	CASE COMP., FUSE .....	1	-	-	-----	EDS1,EDS1/A
10	38240-VA3-900	PROTECTOR, CIRCUIT (1.0A) ...	1	-	-	-----	EDS1,EDS1/A
11	38250-898-000	LENS ASSY., PROTECTOR .....	1	-	-	-----	EDS1,EDS1/A
12	38251-898-000	LENS .....	1	-	-	-----	EDS1,EDS1/A
13	38252-898-000	CAP, LENS .....	1	-	-	-----	EDS1,EDS1/A
14	38253-898-000	SPRING, COIL .....	1	-	-	-----	EDS1,EDS1/A
15	38254-898-000	HOLDER, LENS .....	1	-	-	-----	EDS1,EDS1/A
16	90101-692-000	SCREW, GLOVE BOX .....	1	-	-	-----	EDS1,EDS1/A,EDT1,EDT1/A,EDT3



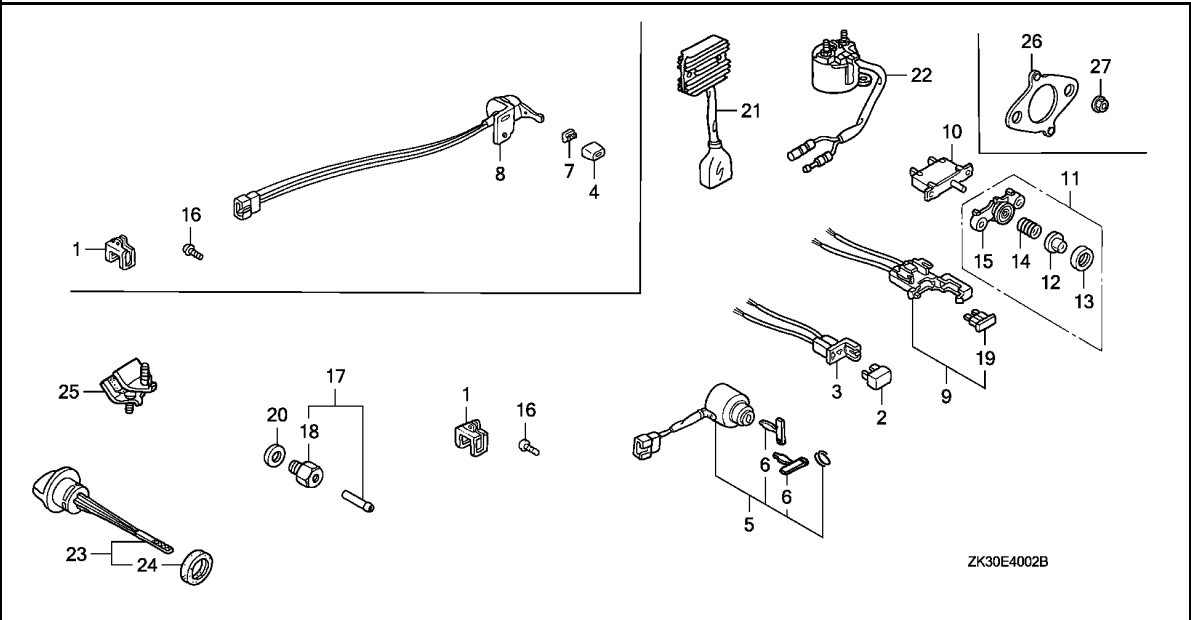

Ref. No.	Part No.	Description	Reqd. QTY			Serial No.	Parts catalogue code
			GX	340K1			
			(1)	(2)	(3)		
17	90131-ZE3-790	PLUG, OIL DRAIN .....	2	-	-	-----	SKE,SKE/A,SKZ/A
18	92800-12000	BOLT, DRAIN PLUG, 12MM .....	2	-	-	2673112	----- SKZ
19	98200-30500	FUSE, BLADE (5A) .....	1	-	-	-----	----- SKE,SKE/A,SKZ/A
20	94109-12000	WASHER, DRAIN PLUG, 12MM ....	2	-	-	-----	----- SKZ
21	31750-769-751	RECTIFIER ASSY., REGULATOR ..	1	-	-	-----	----- EDS1,EDS1/A
22	35850-766-003	SWITCH ASSY., STARTER MAGNETIC	1	-	-	-----	----- SKE,SKE/A,SKZ/A
23	15600-ZE3-791	CAP ASSY., OIL FILLER .....	1	-	-	-----	----- SKZ
24	15625-ZE8-000	PACKING, OIL FILLER CAP .....	1	-	-	-----	----- STJ,STJ/A
25	68325-899-000	RUBBER, BOTTOM .....	2	-	-	-----	----- STJ,STJ/A
			4	-	-	-----	----- VS4,VS6
				-	-	-----	----- STR,STR/A
26	18333-ZF6-W01	GASKET, EX. PIPE .....	1	-	-	-----	----- VWC,VWE
27	94050-08000	NUT, FLANGE, 8MM .....	2	-	-	-----	----- VWC,VWE



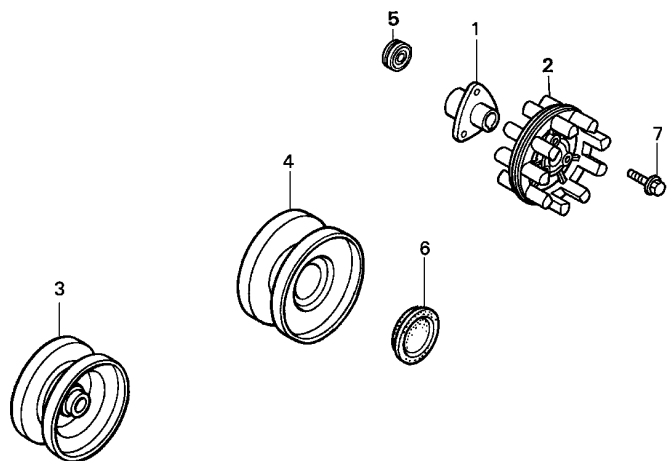

ZK30-E4003A

Ref. (Relative ref. Number)  
No. L.O.N. Description F.R.T.

NO INFORMATION .....

Ref. No.	Part No.	Description	Reqd. QTY			Serial No.	Parts catalogue code
			GX	340K1			
			(1)	(2)	(3)		
1	42703-740-000	HUB, CRAWLER SPROCKET .....	2	-	-	-----	LJS1
2	42756-740-C00	WHEEL, DRIVE SPROCKET .....	2	-	-	-----	LJS1
3	42757-740-C00	WHEEL, DRIVEN .....	2	-	-	-----	LJS1
4	42758-740-010	WHEEL, INDUCTION .....	4	-	-	-----	LJS1
5	91256-740-003	OIL SEAL, 24X47X15 .....	6	-	-	-----	LJS1
6	91261-740-003	PLUG, SEAL, 47X10 .....	6	-	-	-----	LJS1
7	95701-10032-00	BOLT, FLANGE, 10X32 .....	6	-	-	-----	LJS1

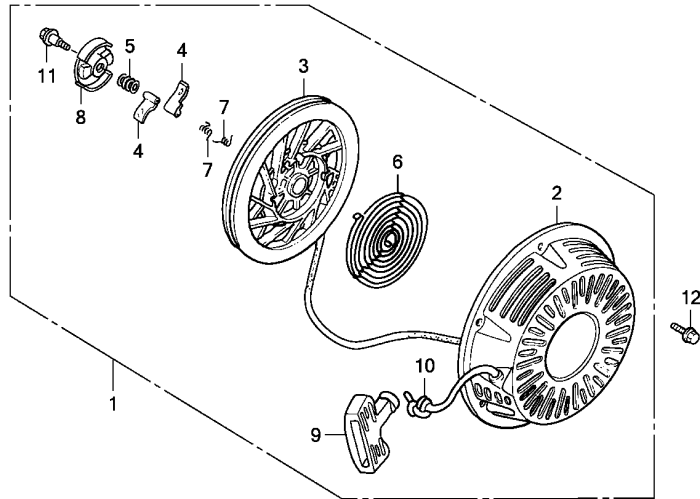

ZK30E4004

Ref. No.	L.O.N.	(Relative ref. Number) Description	F.R.T.
1	1121B9	STARTER, RECOIL .....	0.1
3	1121B1	REEL, RECOIL STARTER .....	0.3
4	1121B0	RATCHET, STARTER AND/OR SPRING, RATCHET .....	0.2
.NOTE: Same time for two units			
6	1121B7	SPRING, RECOIL STARTER RETURN (5)	0.3
8	1121B2	RETAINER, SPRING .....	0.2
10	1121B3	ROPE, RECOIL STARTER .....	0.3

Ref. No.	Part No.	Description	Reqd. QTY			Serial No.	Parts catalogue code
			GX	(1)	(2)		
1	28400-ZE3-W01ZH	STARTER ASSY., RECOIL	1	-	-	-	VS2,VS3,VS4,VS5,VS6,VS7
		*NH105*...MAT BLACK (#15-#20)	1	-	-	-	ES2
	28400-ZE3-W01ZL	*Y131*...LIGHTNING YELLOW	1	-	-	-	ES2
	28400-ZE3-W01ZM	*T77*...SEC WINE RED	1	-	-	-	ES2
	28400-ZE3-W01ZP	*R280*...POWER RED	1	-	-	-	ES2
2	28410-ZE3-W01ZH	CASE COMP., RECOIL STARTER	1	-	-	-	VS2,VS3,VS4,VS5,VS6,VS7
		*NH105*...MAT BLACK (#15-#20)	1	-	-	-	ES2
	28410-ZE3-W01ZL	*Y131*...LIGHTNING YELLOW	1	-	-	-	ES2
	28410-ZE3-W01ZM	*T77*...SEC WINE RED	1	-	-	-	ES2
	28410-ZE3-W01ZP	*R280*...POWER RED	1	-	-	-	ES2
3	28421-ZE3-W01	PULLEY, RECOIL STARTER .....	1	-	-	-	ES2,VS2,VS3,VS4,VS5,VS6,VS7
4	28422-ZE2-W01	RATCHET, STARTER .....	2	-	-	-	ES2,VS2,VS3,VS4,VS5,VS6,VS7
5	28441-ZE2-W01	SPRING, FRICTION .....	1	-	-	-	ES2,VS2,VS3,VS4,VS5,VS6,VS7
6	28442-ZE2-W01	SPRING, STARTER RETURN .....	1	-	-	-	ES2,VS2,VS3,VS4,VS5,VS6,VS7
7	28443-ZE2-W01	SPRING, RATCHET .....	2	-	-	-	ES2,VS2,VS3,VS4,VS5,VS6,VS7
8	28444-ZE2-W01	RETAINER, SPRING .....	1	-	-	-	ES2,VS2,VS3,VS4,VS5,VS6,VS7
9	28461-ZE2-W02	GRIP, STARTER .....	1	-	-	-	ES2,VS2,VS3,VS4,VS5,VS6,VS7
10	28462-ZE3-W01	ROPE, RECOIL STARTER .....	1	-	-	-	ES2,VS2,VS3,VS4,VS5,VS6,VS7
11	90004-ZE2-W01	SCREW, CENTER .....	1	-	-	-	ES2,VS2,VS3,VS4,VS5,VS6,VS7
12	90008-ZE2-003	BOLT, FLANGE, 6X10 .....	3	-	-	-	ES2,VS2,VS3,VS4,VS5,VS6,VS7



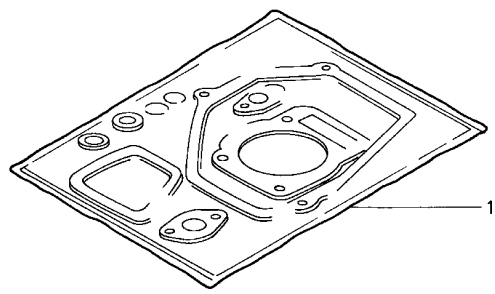

HENG-X0003

Ref. L.O.N. (Relative ref. Number) F.R.T.  
No. Description

NO INFORMATION .....

Ref. No.	Part No.	Description	Reqd. QTY			Serial No.	Parts catalogue code
			(1)	(2)	(3)		
1	061A1-ZE3-G00	GASKET KIT .....	1	-	-	-----	QNE9,QNE9/A
	061A1-ZE3-G50	.....	1	-	-	-----	QAQ
	061A1-ZE3-G80	.....	1	-	-	-----	HAQ
	061A1-ZE3-851	.....	1	-	-	-----	2582468 STR
	061B1-ZE3-010	.....	1	1	-	-----	3032023 LHB3,SHB3
			1	-	-	-----	2179883 BJ,LJ,L1,P1,Q1,SJ,STJ,STP,STQ,S1,V1,YJ
			1	-	-	-----	EDN,EDS,EDS3,EDS5,EN,ES,ET,ETS,ETX,HA,HH,HX,LHC,LP,LXZ,QA,QAE,QAP
			1	-	-	-----	QAPE,QHC,QNE,QXEB,SHEZ,SHT,SXP,VA,VAA,VAAE,VAH1,VAH2,VDE,VE,VHE
			1	-	-	-----	VNG,VNG1,VNG2,VWA,VXA,VXG
			1	-	-	-----	3032023 ED7,ED8,ES1,LH,LHE,LHQ4,LKE,LX,LXE,LXE4,LXE8,LXQ4,LXU,PX,QE,QH
			1	-	-	-----	QHB3,QHE,QHQ4,QME0,QX,QXB,QXC,QXE,QXE4,QXE8,QXQ4,QXU,SE,SH,SHE
			1	-	-	-----	SHQ4,SME0,SX,SXB,SXE,SXEB,SXE4,SXE8,SXQ4,SXU,VH,VX,VXB,VXE,VXEB
			1	-	-	-----	VXE4,VXE8,VXQ4,VXU,VXU1,VX8
			1	-	-	-----	3129573 PKX4
			1	-	-	-----	3279758 EDS1,EDT1,ED6,ED9,ES3,ES4,PKT4,PXE8,QME8,QP,QT,QXC4,SWX
	061C1-ZE3-820	.....	1	-	-	-----	VXB2
	06111-ZK3-U60	.....	1	-	-	-----	2563594 QMX2
			1	-	-	-----	2563594 3279758 QAH2,VWC2,VWS2
	06111-ZK3-U61	.....	1	-	-	-----	QAH2/A,VWC2/A,VWS2/A
			1	-	-	-----	3279759 QAH2,VWC2,VWS2
	06111-ZK3-W00	.....	1	-	-	-----	EDT2
			1	-	-	-----	3279758 EDS2
	06111-ZK3-W01	.....	1	-	-	-----	EDS2/A,EDT,EDT/A,ENT,ENT/A,ENT2,VC2,VC2/A
			1	-	-	-----	3279759 EDS2



# PART NO. INDEX

**2-L 2**

Part Number	Address	Page	Ref.	Part Number	Address	Page	Ref.	Part Number	Address	Page	Ref.	Part Number	Address	Page	Ref.				
16100-ZE3-W31	K11	153	11					G15	93	14		2-F10	280	14	16952-ZB4-005	2-D7	245	21	
16100-ZE3-W32	K12	154	11	16221-ZF6-800	M4	178	15	H1	95	8		2-G3	289	15		2-D9	247	3	
16100-ZE3-W50	K11	153	11		M4	178	15	16531-Z0A-000	G7	85	16	2-G6	292	6		2-J12	346	3	
16100-ZE3-W51	K11	153	11		M15	189	7		G15	93	15	16578-ZE1-000	2-F11	281	15	16952-ZB7-000	2-D13	251	6
16100-ZE3-W61	M15	189	2	16223-ZA0-700	L3	161	20		H1	95	9		2-G3	289	16	16953-ZE1-712	N2	192	23
16100-ZH9-W30	K13	155	11	16223-ZA0-800	L3	161	20	16531-ZE2-000	G6	84	16	16581-ZE3-W00	2-F11	281	16	16953-ZE1-811	L5	163	26
16100-ZH9-W31	K13	155	11	16223-ZE3-800	L4	162	20		G15	93	15		2-G3	289	17		M5	179	22
16100-ZK3-S61	M12	186	53		M8	182	15	16541-ZE3-010	H1	95	9	16582-883-300	2-B8	214	1	16953-ZE1-812	L6	164	26
16124-ZE0-005	K13	155	13		M13	187	14		F4	66	3		2-G3	289	19		L7	165	26
	M4	178	11	16223-ZE3-W00	L3	161	20	16550-ZE3-700	2-F3	273	1	16584-883-300	K2	144	2	16954-ZE1-811	M5	179	22
	M7	181	10		M5	179	16		2-G2	288	1		2-F12	282	19		L7	165	27
	M13	187	9		M15	189	8	16551-ZE3-000	2-F3	273	2		2-G3	289	20		M5	179	23
	M15	189	3		M16	190	14		2-G2	288	2		2-G6	292	7	16954-ZE1-812	L7	165	27
	M16	190	9		N2	192	16	16555-ZE3-000	2-G6	292	1	16590-ZE2-772	N2	192	20		M5	179	23
	N2	192	9	16223-ZF6-000	L3	161	20		2-F4	274	3	16590-ZE2-812	L4	162	22		N3	193	24
16148-141-881	M7	181	11		M4	178	16		2-G2	288	3		M5	179	18	16954-ZF0-841	L7	165	27
	M13	187	10	16230-ZE3-701	M8	182	16	16555-ZE3-W00	2-G6	292	2	16590-ZE3-L60	M16	190	15	16955-ZE1-000	2-C14	236	2
	N2	192	10		M13	187	15		2-F5	275	3	16590-ZE3-L62	M16	190	15	16955-ZE2-H21	N3	193	25
16166-ZE3-701	M7	181	12	16230-ZE3-702	M8	182	16	16561-ZE3-000	2-G2	288	3	16590-ZE3-L63	M16	190	15	16956-ZE1-811	L8	166	28
	M13	187	11	16252-ZA1-010	N2	192	17		2-F5	275	4	16591-ZE3-H00	2-B8	214	2		M5	179	24
16166-ZE3-811	M16	190	10	16260-ZB7-000	M13	187	16		2-G2	288	4	16592-883-310	2-F13	283	20		N3	193	26
16166-ZE3-F10	M7	181	12	16260-ZE2-722	M8	182	17		2-G6	292	3		2-G3	289	21	16957-707-005	2-D13	251	7
16166-ZE3-F30	K15	157	14	16260-ZE2-723	M8	182	17	16561-ZE3-710	2-F5	275	4	16593-ZG1-700	2-G6	292	8	16957-ZE1-812	L9	167	29
16166-ZE3-H61	N2	192	11	16260-ZE3-D21	M8	182	17	16562-896-000	N2	192	19	16594-883-010	L5	163	23		M5	179	25
16166-ZE3-W10	K13	155	14	16261-ZB7-000	M13	187	17	16562-ZE3-000	2-F6	276	5		M5	179	19		N3	193	27
16166-ZE3-W20	K14	156	14	16261-ZE2-702	M8	182	18		2-G2	288	5		M16	190	17	16958-397-771	2-D7	245	22
	M4	178	12	16262-ZB7-000	M13	187	18		2-G6	292	4		2-F13	283	21		2-D9	247	4
16166-ZE3-W50	K15	157	14	16262-ZE2-711	M8	182	19	16562-ZE3-700	2-F6	276	5		2-G3	289	22		2-J12	346	4
16166-ZH9-820	K15	157	14	16263-ZA0-000	M9	183	20		2-G2	288	5	16597-ZE2-780	2-B8	214	3	16959-471-831	2-D7	245	23
16172-ZE3-W10	K15	157	15		M13	187	19	16570-ZE3-700	2-F7	277	9	16599-ZG1-M10	2-F13	283	22		2-D9	247	5
	M12	186	52	16264-ZB7-000	M13	187	20		2-G3	289	9	16610-ZE1-000	L5	163	24		2-J12	346	5
	M15	189	4	16264-ZE2-701	M9	183	21	16570-ZE3-710	2-F7	277	9		M5	179	20	16963-443-901	2-D13	251	8
	N2	192	12	16264-ZE2-780	N2	192	18	16570-ZE3-721	2-F7	277	10		M15	189	9	16967-196-005	2-D13	251	9
16173-001-004	K16	158	16	16265-ZB7-000	M13	187	21	16570-ZE3-H02	2-G6	292	5	16610-ZE2-780	N2	192	21	16967-GA6-671	2-D7	245	24
	N2	192	13	16265-ZE2-721	M9	183	22	16570-ZE3-L60	2-G2	288	6	16611-ZE2-711	M9	183	26		2-D9	247	6
	2-D7	245	19	16266-ZB7-000	M13	187	22	16570-ZE3-L61	2-G3	289	6	16611-ZE3-D21	M9	183	26		2-J12	346	6
	2-D9	247	1	16267-ZB7-003	M13	187	23	16570-ZE3-R90	2-G3	289	7	16613-893-000	M9	183	27	16967-ZE0-811	L9	167	30
	2-J12	346	1	16268-893-000	2-G7	293	1	16570-ZE3-W00	2-F7	277	6	16615-893-000	M9	183	28		N3	193	28
16200-ZJ1-003	M16	190	11	16268-ZE2-721	M9	183	23		2-G3	289	8	16615-ZE2-810	L5	163	25	16990-ZB7-005	2-D13	251	10
16211-ZB8-000	M13	187	12	16269-890-800	2-B6	212	1	16570-ZE3-W10	2-F7	277	7		M5	179	21				
16211-ZE2-000	K16	158	17	16269-ZA0-800	M9	183	24		2-G3	289	10		M16	190	16	17000			
16211-ZE3-000	L1	159	17		M13	187	24	16570-ZE3-W20	2-F7	277	8	16617-ZE3-H00	M16	190	17				
	M16	190	12	16271-ZE2-010	N4	194	1		2-G5	291	42		N2	192	22	17210-ZE3-010	N5	195	2
	N2	192	14		N15	205	1	16570-ZE3-W30	2-F7	277	6		2-G3	289	23		N16	206	2
16211-ZE3-700	M7	181	13		N16	206	1		2-G3	289	8	16731-ZE2-003	J10	136	2		2-B2	208	2
16211-ZF6-000	L1	159	17		2-B2	208	1	16570-ZE3-W40	2-F7	277	7	16851-ZB7-000	2-D13	251	1	17211-883-010	2-B6	212	2
	M4	178	13	16400-ZE2-703	M9	183	25	16570-ZK3-870	2-F7	277	6	16852-ZB7-000	2-D13	251	2	17211-899-000	2-B3	209	3
	M15	189	5	16400-ZE2-704	M9	183	25	16570-ZK3-D20	2-F7	277	10	16853-ZB7-000	2-D13	251	3	17212-ZB4-003	2-B3	209	4
16220-ZA0-702	L2	160	18	16500-ZE2-702	E5	51	9	16570-ZK3-S60	2-F7	277	10	16854-ZE1-000	2-C13	235	1	17212-ZE3-L60	2-B6	212	3
	M4	178	14	16510-ZE3-000	G3	81	12	16571-ZE3-W00	2-F8	278	11	16854-ZH8-000	2-C13	235	1	17218-ZE3-000	N5	195	3
	M15	189	6		G14	92	11		2-G3	289	12		2-D11	249	22		N16	206	3
16221-ZA0-700	L2	160	19		H1	95	5	16571-ZE3-W10	2-F8	278	11		2-D12	250	1		2-B2	208	3
16221-ZA0-800	L2	160	19	16511-ZE8-000	G4	82	13		2-G3	289	12	16857-ZB7-000	2-D13	251	4	17219-ZE3-840	N16	206	4
16221-ZB7-800	M13	187	13		G14	92	12	16574-ZE1-000	2-F9	279	12	16930-ZB7-013	2-D13	251	5	17220-ZB4-003	2-B3	209	5
16221-ZE3-800	L3	161	19		H1	95	6		2-G3	289	13	16950-732-000	2-D12	250	2	17220-ZB7-000	2-B3	209	5
	M7	181	14	16512-ZE3-000	G5	83	14	16575-ZE2-W00	2-F9	279	13	16950-ZB4-015	2-D7	245	20	17220-ZE3-L60	2-B6	212	4
	M16	190	13		G15	93	13		2-G3	289	14		2-D9	247	2	17220-ZE3-L61	2-B6	212	4
	N2	192	15		H1	95	7	16576-891-000	L4	162	21		2-J12	346	2	17222-ZB8-000	2-B3	209	6
16221-ZF6-000	L3	161	19	16513-ZE2-000	G5	83	15		M5	179	17	16952-883-005	2-D12	250	3	17222-ZC2-000	2-B3	209	6

3



# PART NO. INDEX

Part Number	Address	Page	Ref.	Part Number	Address	Page	Ref.	Part Number	Address	Page	Ref.	Part Number	Address	Page	Ref.
28400-ZE3-W01ZE I12		122	1		2-E10	264	2	31510-ZE1-811	2-E3	257	4		2-H6	308	1
28400-ZE3-W01ZH I12		122	1	30500-ZF6-W03	2-E3	257	1	31510-ZE2-811	2-E3	257	3	31610-ZE3-W22ZC	2-G8	294	4
	2-K1	351	1		2-E10	264	2		2-E10	264	7	31610-ZE3-W23ZA	2-H6	308	1
28400-ZE3-W01ZK I13		123	1	30561-ZB4-000	2-J8	342	2	31510-ZE3-003	2-E3	257	4	31610-ZE3-W23ZB	2-G9	295	4
28400-ZE3-W01ZL I13		123	1		2-J9	343	1		2-E10	264	8		2-H6	308	1
	2-K1	351	1		2-J14	348	1	31510-ZE3-811	2-E10	264	8	31610-ZE3-W23ZD	2-G9	295	4
28400-ZE3-W01ZM I13		123	1	30600-ZE1-013	2-E3	257	2	31511-ZB4-000	2-H15	317	1		2-H6	308	1
	2-K1	351	1		2-E10	264	4	31511-ZE2-W00	2-E3	257	5	31610-ZE3-W31ZB	2-G8	294	3
28400-ZE3-W01ZN I13		123	1	30700-ZB7-013	2-E7	261	21		2-E9	263	4		2-H11	313	3
28400-ZE3-W01ZP I13		123	1	30700-ZE1-013	2-E8	262	22		2-E11	265	27	31610-ZE3-W32ZA	2-H11	313	3
	2-K1	351	1				22	31511-ZE3-000	2-E3	257	6	31610-ZE3-W32ZB	2-G8	294	4
28403-ZE3-H60 K1		143	20		2-E9	263	2		2-E9	263	5		2-H11	313	3
28410-ZE3-W01ZA I13		123	2		2-E10	264	5		2-E11	265	9	31610-ZE3-W33ZA	2-H2	304	2
28410-ZE3-W01ZB I13		123	2	30701-883-000	J13	139	7	31512-880-810	2-H15	317	2		2-H11	313	3
28410-ZE3-W01ZD I14		124	2		2-E9	263	3	31512-ZB7-000	2-H16	318	2	31610-ZE3-W33ZB	2-G9	295	4
28410-ZE3-W01ZE I14		124	2		2-E10	264	6	31512-ZE2-000	2-E4	258	7		2-H2	304	2
28410-ZE3-W01ZF I14		124	2						2-E9	263	6		2-H11	313	3
28410-ZE3-W01ZH I14		124	2	31000					2-E11	265	24	31610-ZE3-W33ZD	2-G9	295	4
	2-K1	351	2					31512-ZG3-000	2-E9	263	7		2-H2	304	2
28410-ZE3-W01ZK I14		124	2	31100-ZE3-700	2-D15	253	6		2-E11	265	25		2-H11	313	3
28410-ZE3-W01ZL I14		124	2	31100-ZE3-701	2-D15	253	6	31513-634-000	2-H15	317	3	31610-ZE3-W41ZB	2-G9	295	4
	2-K1	351	2	31100-ZE3-711	2-D15	253	7	31513-ZB7-000	2-H16	318	3		2-H9	311	1
28410-ZE3-W01ZM I14		124	2	31100-ZE3-712	2-D16	254	7	31521-880-000	2-H15	317	4		2-H11	313	3
	2-K1	351	2	31100-ZE3-721	2-D16	254	8	31550-899-000	2-H15	317	5	31610-ZE3-W42ZA	2-H11	313	3
28410-ZE3-W01ZN I14		124	2	31100-ZE3-722	2-D16	254	8	31600-890-951	2-E11	265	11	31610-ZE3-W42ZB	2-G9	295	4
28410-ZE3-W01ZP I14		124	2	31100-ZE3-831	2-E1	255	11	31600-ZE2-861	2-E11	265	11		2-H11	313	3
	2-K1	351	2	31100-ZE3-U10	2-E1	255	12		2-G8	294	2	31610-ZE3-W42ZD	2-G9	295	4
28421-ZE3-W01 I15		125	3	31100-ZE3-W00	2-D15	253	5		2-H11	313	2		2-H9	311	1
	2-K1	351	3	31100-ZE3-W01	2-D15	253	5	31610-ZE3-013ZB	2-G16	302	1		2-H12	314	3
28422-ZE2-W01 I16		126	4	31100-ZE3-W10	2-D15	253	5	31610-ZE3-013ZD	2-G16	302	1	31610-ZF6-W41ZA	2-G9	295	4
	2-K1	351	4	31100-ZE3-W20	2-D15	253	5	31610-ZE3-812ZB	2-G10	296	5	31610-ZF6-W41ZB	2-G9	295	4
28441-ZE2-W01 J1		127	5	31100-ZE3-W21	2-D15	253	5	31610-ZE3-812ZD	2-G10	296	5	31610-ZF6-W42ZA	2-G9	295	4
	2-K1	351	5	31161-ZE2-000	F5	67	4	31610-ZE3-842ZB	2-G10	296	5	31610-ZF6-W42ZB	2-G9	295	4
28442-ZE2-W01 J2		128	6	31204-ZA0-003	2-E12	266	1	31610-ZE3-862ZB	2-G10	296	5	31610-ZF6-W42ZC	2-G9	295	4
	2-K1	351	6	31206-ZE3-003	2-E12	266	2	31610-ZE3-W01ZB	2-H2	304	2	31610-ZF6-W42ZE	2-G9	295	4
28443-ZE2-W01 J3		129	7	31207-ZE3-003	2-E13	267	3	31610-ZE3-W02ZB	2-H2	304	2	31610-ZF6-W51ZB	2-G9	295	4
	2-K1	351	7	31210-ZB8-013	2-E13	267	4	31610-ZE3-W11ZB	2-G8	294	3	31610-ZK6-W41ZA	2-G9	295	4
28444-ZE2-W01 J4		130	8	31210-ZE3-013	2-E13	267	4		2-H4	306	2	31610-ZK6-W41ZB	2-G9	295	4
	2-K1	351	8	31210-ZE3-023	2-E13	267	4	31610-ZE3-W11ZC	2-G8	294	3	31610-ZK6-W42ZA	2-G9	295	4
28450-ZE3-W11 2-D14		252	3	31210-ZE3-A11	2-E13	267	4	31610-ZE3-W12ZA	2-H6	308	1	31610-ZK6-W42ZB	2-G10	296	4
28451-ZE3-W01 2-D15		253	4	31211-ZE2-003	2-E13	267	5	31610-ZE3-W12ZB	2-G8	294	4	31610-ZK6-W42ZC	2-G10	296	4
28461-ZE2-W01 J5		131	10	31212-ZE3-003	2-E13	267	6		2-H4	306	2	31612-ZE2-003	2-G10	296	6
28461-ZE2-W02 J5		131	10	31213-ZE2-003	2-E14	268	7		2-H6	308	1		2-G16	302	2
	2-K1	351	9	31215-ZE2-003	2-E14	268	8	31610-ZE3-W12ZC	2-G8	294	4		2-H2	304	3
28462-ZE3-W01 J6		132	11	31218-ZE3-003	2-E15	269	9	31610-ZE3-W12ZD	2-H6	308	1		2-H4	306	3
	2-K1	351	10	31219-ZE2-003	2-E15	269	10	31610-ZE3-W13ZB	2-G9	295	4		2-H6	308	2
28469-ZE2-W01 J7		133	12	31222-ZE3-791	2-E15	269	11		2-H4	306	2		2-H9	311	2
				31231-ZE2-003	2-E15	269	12		2-H6	308	1		2-H12	314	4
30000				31232-ZB7-003	2-E15	269	13	31610-ZE3-W13ZC	2-H4	306	2	31614-ZE2-003	2-G10	296	7
				31232-ZE3-003	2-E16	270	14	31610-ZE3-W13ZD	2-H4	306	2		2-G16	302	3
				31233-ZE2-003	2-E16	270	15		2-H6	308	1		2-H2	304	4
30401-HA0-000 2-H14		316	1	31425-ZB4-010ZA	2-J9	343	2	31610-ZE3-W13ZE	2-G9	295	4		2-H4	306	4
30500-ZE2-013 2-E2		256	1	31425-ZB4-010ZB	2-J9	343	2		2-H4	306	2		2-H6	308	3
	2-E9	263	1	31425-ZB4-010ZC	2-J9	343	2		2-H6	308	1		2-H9	311	3
	2-E10	264	2	31425-ZB4-010ZD	2-J9	343	2	31610-ZE3-W21ZB	2-G8	294	3		2-H12	314	5
30500-ZE2-023 2-E9		263	1	31462-ZB4-000	2-J9	343	3		2-H4	306	2	31615-ZE3-003ZA	2-G11	297	8
	2-E10	264	2	31482-ZB4-003	2-J9	343	4	31610-ZE3-W21ZC	2-G8	294	3		2-H6	308	4
30500-ZF6-W01 2-E9		263	1	31483-ZB4-003	2-J9	343	5	31610-ZE3-W22ZB	2-G8	294	4		2-H9	311	4
	2-E10	264	2	31507-ZB7-000	2-H16	318	1		2-H4	306	2		2-H12	314	6
30500-ZF6-W02 2-E3		257	1												
												32000			
												32100-ZB7-A00	2-H14	316	4
												32100-ZB7-A01	2-H14	316	4
												32100-ZE3-L60	2-E11	265	14
												32110-ZE2-860	2-G11	297	12

3









# PART NO. INDEX

Part Number	Address	Page	Ref.	Part Number	Address	Page	Ref.	Part Number	Address	Page	Ref.	Part Number	Address	Page	Ref.
95701-06010-00	2-C11	233	13						M5	179	31				
			19	98079-55854	2-J5	339	14		M11	185	50	99204-ZE2-0380	M12	186	51
95701-06012-00	F11	73	19	98079-55855	E11	57	19	99101-ZH7-0880	L15	173	36	99204-ZE2-0400	M14	188	30
	G15	93	24		E12	58	19	99101-ZH7-0900	L15	173	36		M3	177	37
	2-C11	233	13	98079-56841	E13	59	19	99101-ZH7-0920	L14	172	36				
			19		E13	59	19		L14	172	36				
95701-06016-00	2-G5	291	41	98079-56846	2-J5	339	14		L15	173	36				
95701-06018-00	2-J11	345	25		E14	60	19	99101-ZH7-0950	M1	175	36				
95701-06020-00	2-J11	345	25	98079-56854	2-J5	339	14		L14	172	36				
95701-06022-00	2-D11	249	21		E15	61	19		M1	175	36				
	2-J13	347	22	98079-56855	2-J5	339	14		M11	185	50				
95701-06025-00	2-E11	265	23		E15	61	19	99101-ZH7-0980	N1	191	23				
95701-06035-08	2-B8	214	16	98200-30500	2-J5	339	14		L14	172	36				
95701-06040-08	2-J11	345	26		2-G15	301	31		M1	175	36				
95701-08016-08	2-C11	233	14		2-H1	303	23		M11	185	50				
95701-08020-00	2-C11	233	15		2-H3	305	24	99101-ZH7-1000	N1	191	23				
95701-08025-00	2-D7	245	18		2-H5	307	24		M1	175	36				
	2-D12	250	19		2-H7	309	24		M11	185	50				
	2-I4	322	11		2-H14	316	13	99101-ZH8-0880	L15	173	36				
95701-08028-00	2-D7	245	18		2-J11	345	28	99101-ZH8-0900	L14	172	36				
95701-08030-00	2-B6	212	17	98200-31000	2-J15	349	19		L15	173	36				
95701-08035-08	2-F2	272	22		2-H14	316	14		L16	174	36				
95701-08040-00	G11	89	23	98200-31500	2-J11	345	28	99101-ZH8-0920	L13	171	36				
	G15	93	25		2-G15	301	31		L14	172	36				
	G16	94	26		2-H5	307	24		L15	173	36				
	H2	96	16		2-H7	309	24		M1	175	36				
	2-I3	321	15	98200-32000	2-H13	315	23		M5	179	31				
	2-I4	322	12	98200-32500	2-J7	341	22		M14	188	29				
95701-08045-00	G15	93	25		2-G15	301	31	99101-ZH8-0950	N3	193	34				
95701-08070-00	2-C11	233	16		2-H10	312	16		L13	171	36				
	2-J8	342	9		2-H13	315	23		L14	172	36				
95701-10032-00	2-J16	350	7	99000					L15	173	36				
95701-10080-00	E9	55	18						M1	175	36				
95725-10080-00	E9	55	18	99001-10120	2-J5	339	15		M5	179	31				
95801-08020-18	2-J8	342	10		2-J6	340	7		M11	185	50				
	2-J11	345	27		2-J7	341	14		M14	188	29				
95900-08025-00	2-I4	322	11		2-J8	342	11	99101-ZH8-0980	N3	193	34				
				99001-10140	2-J8	342	11		L13	171	36				
96000					2-J5	339	16		L14	172	36				
				99001-14170	2-J7	341	23		M1	175	36				
96100-62020-00	F11	73	20		2-J5	339	17		M5	179	31				
	G11	89	24	99003-20000	2-J8	342	12		M12	186	50				
	G16	94	27	99003-30000	2-J7	341	16		M14	188	29				
	H2	96	17	99003-50000	2-J6	340	8		N3	193	34				
96100-62040-00	G16	94	28	99004-21003	2-J6	340	9	99101-ZH8-1000	M1	175	36				
96100-62060-00	2-I3	321	16		2-J5	339	18		M12	186	50				
96100-62070-00	G12	90	25		2-J6	340	10	99101-ZH8-1020	L12	170	36				
	G16	94	29	99005-01000	2-J7	341	17	99101-ZH8-1050	L13	171	36				
	H2	96	18	99008-02000	2-J6	340	11	99101-ZH8-1080	L13	171	36				
	H5	99	13	99008-02300	2-J6	340	12	99104-ZE0-0450	M15	189	11				
	2-I3	321	16		2-J5	339	19	99204-ZA0-0400	M1	175	37				
96100-63020-00	2-I4	322	13		2-J7	341	18		N1	191	24				
				99101-ZF5-0920	2-J8	342	13	99204-ZA0-0450	M1	175	37				
					L13	171	36		M5	179	32				
					M5	179	31	99204-ZE0-0350	M2	176	37				
98079-55154	E9	55	19		M11	185	50		M12	186	51				
98079-55841	E9	55	19	99101-ZF5-0950	L13	171	36		N1	191	24				
98079-55846	E10	56	19		M5	179	31		N3	193	35				
	E11	57	19	99101-ZF5-0980	M11	185	50	99204-ZE0-0450	M3	177	37				
					L13	171	36		M5	179	32				



# PART NAME INDEX

Part name	Address	Page	Ref.	Part name	Address	Page	Ref.	Part name	Address	Page	Ref.
BOLT, STUD, 8X22 .....	E7	53	13	CAP COMP., FUEL FILLER .....	2-D12	250	5	CIRCLIP, 5MM .....	M5	179	26
BOLT, STUD, 8X32 .....	E7	53	13				6		N1	191	18
BOLT, STUD, 8X34 .....	E7	53	13		2-J12	346	9		N3	193	30
BOLT, STUD, 8X40 .....	E7	53	13	CAP COMP., OIL .....	G1	79	7		2-F15	285	27
BOLT, STUD, 8X47 .....	E7	53	13	CAP, CHOKE DUST .....	M7	181	11		2-G4	290	30
BOLT, STUD, 8X98 .....	E6	52	12		M13	187	10	CLAMPER, CORD .....	J13	139	8
BOX ASSY., CONTROL .....	2-G8	294	3		N2	192	10		2-E3	257	5
			4	CAP, CHOKE LEVER .....	N2	192	17				6
	2-G9	295	4	CAP, LENS .....	2-J11	345	32		2-E9	263	4
	2-G10	296	4		2-J14	348	13				5
			5	CAP, LEVER .....	N3	193	25		2-E11	265	9
	2-G16	302	1	CAP, MUFFLER .....	2-B9	215	5				27
	2-H2	304	2		2-B15	221	6	CLAMP, TUBE .....	M11	185	46
	2-H4	306	2		2-C9	231	11	CLIP A, AIR CLEANER WIRE .....	2-B4	210	9
	2-H6	308	1	CAP, OIL FILLER .....	G1	79	6	CLIP B, AIR CLEANER WIRE .....	2-B4	210	10
	2-H9	311	1		G15	93	16	CLIP, BREATHER TUBE .....	E5	51	10
	2-H11	313	3		H1	95	4		E15	61	21
	2-H12	314	3	CAP, PRE AIR CLEANER .....	2-B1	207	11		2-B3	209	2
BOX, TOOL .....	2-J4	338	1	CARBURETOR ASSY. ....	K11	153	11	CLIP, GOVERNOR HOLDER .....	G8	86	19
BRACKET, CASE MOUNTING .....	2-G10	296	7		K12	154	11		G15	93	19
	2-G16	302	3		K13	155	11		H1	95	11
	2-H2	304	4		M4	178	10	CLIP, HARNESS .....	K1	143	16
	2-H4	306	4		M7	181	9		2-D13	251	16
	2-H6	308	3		M12	186	53		2-E7	261	19
	2-H9	311	3		M13	187	8		2-E11	265	21
	2-H12	314	5		M15	189	2		2-H14	316	11
BRACKET, CENTER .....	2-E13	267	5		M16	190	8	CLIP, HEAD .....	F9	71	15
BRACKET, FR. ....	2-E13	267	6		N2	192	8	CLIP, HIGH TENSION CORD .....	J13	139	7
BRACKET, STRAINER CUP SETTING	2-D13	251	15	CASE COMP., AIR CLEANER .....	2-B3	209	5		2-E9	263	3
BRUSH .....	2-E14	268	8		2-B6	212	4		2-E10	264	6
BUSH, ARM PIVOT .....	M9	183	31	CASE COMP., FUSE .....	2-J10	344	15	CLIP, PISTON PIN, 20MM .....	I5	115	6
BUSH, CHOKE LEVER .....	N3	193	31		2-J14	348	9	CLIP, PURSE LOCK .....	2-F1	271	17
BUSH, CONTROL KNOB .....	2-J10	344	13	CASE COMP., PRE AIR CLEANER ...	2-B1	207	10		2-G14	300	24
	2-J14	348	7	CASE COMP., RECOIL STARTER .....	I13	123	2		2-H1	303	16
					I14	124	2		2-H3	305	17
[ C ]					2-K1	351	2		2-H5	307	17
CABLE ASSY., EARTH .....	2-H15	317	8	CASE, CONTROL .....	2-G10	296	6		2-H7	309	17
	2-H16	318	7		2-G16	302	2	CLIP, TUBE .....	2-H13	315	17
CABLE ASSY., STARTING .....	2-H15	317	6		2-H2	304	3		J10	136	2
	2-H16	318	4		2-H4	306	3		M11	185	45
CAMSHAFT ASSY. ....	I6	116	1		2-H6	308	2		N1	191	22
	I7	117	1		2-H9	311	2		2-B5	211	17
	I8	118	1		2-H12	314	4		2-D6	244	17
CAP ASSY., NOISE SUPPRESSOR ..	2-E7	261	21	CHAMBER SET, FLOAT .....	2-J9	343	2		2-D11	249	20
	2-E8	262	22		K5	147	4		2-D12	250	18
			22		K6	148	5		2-D13	251	17
	2-E9	263	2		K7	149	5				18
	2-E10	264	5		M4	178	4				19
CAP ASSY., OIL FILLER .....	F16	78	4				5	CLIP, VALVE GUIDE .....	2-J13	347	21
	G1	79	5		M6	180	4		E2	48	4
	G13	91	4		M13	187	4	CLIP, WIRE .....	F9	71	14
	G14	92	5		M16	190	4		K1	143	17
	2-J15	349	23	CHOKE SET .....	N2	192	4		2-E11	265	22
CAP COMP., AIR CLEANER .....	N15	205	7		K9	151	10		2-J8	342	2
CAP COMP., FUEL FILLER .....	2-D1	239	6		K10	152	10		2-J9	343	1
			7		K11	153	10		2-J14	348	1
	2-D7	245	29		M4	178	9	CLIP, WIRE HARNESS .....	E7	53	15
	2-D10	248	9	CIRCLIP, 5MM .....	M15	189	1		F9	71	14
					L9	167	31		M10	184	37

# PART NAME INDEX

**2-M 3**

Part name	Address	Page	Ref.	Part name	Address	Page	Ref.	Part name	Address	Page	Ref.
CLIP, WIRE HARNESS .....	2-B4	210	14	CONTROL ASSY. ....	2-F7	277	8	CRANKSHAFT COMP. ....	H4	98	6
	2-G3	289	24				9		H5	99	7
	2-G4	290	31				10				14
CLIP, WIRE HARNESS, 25MM .....	K1	143	15		2-G2	288	6	CUP ASSY., FUEL STRAINER .....	2-D13	251	10
	2-H14	316	9		2-G3	289	6	CUP, FUEL STRAINER .....	L9	167	30
CLIP, WIRE HARNESS, 6MM .....	K1	143	14				7		N3	193	28
	K2	144	9				8		2-D7	245	24
CLUTCH COMP., OVERRUNNING .....	2-E13	267	3				9		2-D9	247	6
COCK ASSY., ELECTRIC FUEL .....	2-D13	251	5				10		2-D13	251	9
COCK ASSY., FUEL .....	2-D7	245	20		2-G5	291	42		2-J12	346	6
	2-D9	247	2		2-G6	292	5	CUSHION, C.D.I. UNIT .....	2-H14	316	1
	2-J12	346	2	CONTROL UNIT, SOLENOID .....	2-H14	316	5				
COIL ASSY., CHARGE .....	2-E5	259	8	CORD, EARTH .....	F5	67	4	[ D ]			
			9	CORD, STOP SWITCH .....	2-E5	259	12	DEFLECTOR COMP., MUFFLER .....	2-C2	224	12
			10		2-E9	263	11	DIAPHRAGM ASSY. ....	M9	183	25
			11		2-E11	265	15	DIODE ASSY. ....	2-J9	343	7
	2-E9	263	8	COUNTERSHAFT COMP. ....	2-I1	319	4				8
			9		2-I4	322	4	DIODE ASSY., SOLENOID .....	2-H14	316	2
			10	COUPLER COMP. ....	2-J9	343	9	DOWEL PIN, 12X20 .....	E7	53	16
			17		2-J14	348	3	DOWEL PIN, 8X12 .....	G9	87	20
	2-E11	265	12	COVER ASSY., CRANKCASE .....	F14	76	2		G15	93	23
			13		F15	77	2		H1	95	12
			26		G13	91	2	DOWEL PIN, 8X14 .....	2-I3	321	14
COIL ASSY., IGNITION .....	2-E2	256	1		H1	95	2		2-I4	322	10
	2-E3	257	1	COVER ASSY., GEAR CASE .....	2-I1	319	1	DRIVER 2, PLUS SCREW .....	2-J7	341	16
	2-E9	263	1		2-I4	322	1	DRIVER 3, MINUS SCREW .....	2-J6	340	8
	2-E10	264	2	COVER B, MAGNETIC SWITCH .....	2-H16	318	6	DRIVER, SCREW .....	2-J4	338	4
COIL ASSY., LAMP .....	2-E3	257	3	COVER COMP., AIR CLEANER .....	N15	205	2	[ E ]			
			4		N16	206	5	ELBOW COMP., AIR CLEANER .....	N11	201	9
	2-E10	264	7		2-B3	209	7		N15	205	6
			8		2-B4	210	8		N16	206	9
COLLAR B, AIR CLEANER .....	N10	200	8	COVER COMP., FAN .....	J11	137	3		2-B2	208	9
	N15	205	4		J12	138	3		2-B6	212	10
	N16	206	8		J13	139	3	ELEMENT, AIR CLEANER .....	2-B8	214	10
	2-B2	208	8		K1	143	18		N5	195	2
	2-B8	214	9		K2	144	4		N16	206	2
COLLAR, 10X16X53 .....	2-J8	342	1	COVER COMP., HEAD .....	E3	49	6		2-B2	208	2
COLLAR, AIR CLEANER .....	N9	199	7		E4	50	6		2-B3	209	3
	N15	205	3		E5	51	6	EMBLEM .....	2-I5	323	3
	N16	206	7	COVER COMP., MUFFLER .....	2-B10	216	9		2-I6	324	3
	2-B2	208	7		2-C2	224	13		2-I7	325	3
	2-B6	212	8	COVER COMP., RR. MUFFLER .....	2-B10	216	10		2-I11	329	34
	2-B7	213	20		2-C3	225	14		2-I12	330	1
	2-B8	214	7	COVER, AIR CLEANER .....	N6	196	4		2-I14	332	1
			8		N7	197	4		2-I16	334	1
COLLAR, AIR CLEANER CASE .....	2-B9	215	1		2-B2	208	4		2-J2	336	1
	2-B12	218	1		2-B6	212	6	E-RING, 2MM .....	M11	185	42
COLLAR, CONTROL BOX .....	2-J11	345	23		2-B8	214	4	E-RING, 4MM .....	M11	185	43
COLLAR, LEVER .....	M10	184	36	COVER, BATTERY .....	2-H16	318	3		N3	193	29
COLLAR, SETTING .....	K15	157	15	COVER, BATTERY TERMINAL .....	2-H16	318	5	E-RING, 7MM .....	M11	185	44
	M12	186	52	COVER, CONTROL .....	2-B8	214	2	EXTENSION COMP., OIL FILLER ...	G14	92	9
	M15	189	4	COVER, DUCT .....	H2	96	19				
	N2	192	12	COVER, STARTER MOTOR TERMINAL ..	2-H15	317	7				
COLLAR, STOPPER .....	2-F13	283	22	CRANKSHAFT COMP. ....	H3	97	1				
COLLAR, TANK CUSHION .....	2-D10	248	17				2				
	2-J13	347	18				1				
CONTACTOR ASSY. ....	2-E12	266	1		H4	98	3				
CONTROL ASSY. ....	2-F7	277	6				4				
			7				5				



# PART NAME INDEX

**2-M 4**

Part name	Address	Page	Ref.	Part name	Address	Page	Ref.	Part name	Address	Page	Ref.
[ F ]								[ H ]			
FAN, COOLING .....	2-D14	252	1	GASKET, EX. PIPE .....	2-B15	221	7	HANDLE, BOX WRENCH .....	2-J5	339	10
FILTER COMP., FUEL .....	2-D10	248	11		2-B16	222	7		2-J7	341	7
	2-J12	346	11		2-C9	231	12		2-J8	342	6
FILTER, CUP .....	2-D7	245	23		2-C10	232	6	HARNESS ASSY., ENGINE .....	2-E11	265	14
	2-D9	247	5		2-C11	233	17	HARNESS ASSY., SUB WIRE .....	2-G11	297	11
	2-J12	346	5								
FILTER, DRAIN TUBE .....	2-B4	210	12		2-C12	234	2		2-H9	311	6
FILTER, FUEL .....	2-D3	241	10	GASKET, MUFFLER .....	2-J11	345	29		2-H12	314	8
					2-J15	349	26		2-H13	315	26
	2-D10	248	11		2-B10	216	8		2-H14	316	4
	2-D12	250	9		2-C1	223	10	HEAD COMP., CYLINDER .....	E1	47	1
					2-C2	224	11		E2	48	1
					2-C9	231	7		2-E15	269	12
	2-D13	251	12	Gauge ASSY., FUEL .....	2-C15	237	4	HOLDER, BRUSH .....	L4	162	21
FILTER, OUTER .....	N5	195	3	Gauge ASSY., THICKNESS .....	2-J4	338	6	HOLDER, CABLE .....	M5	179	17
	N16	206	3	Gauge COMP., OIL LEVEL .....	G14	92	6		2-F10	280	14
	2-B2	208	3	GEAR, COUNTER .....	2-I1	319	5		2-G3	289	15
FLANGE COMP., BAFFLE .....	2-C1	223	8	GEAR, DRIVE PINION .....	2-E14	268	7		2-G6	292	6
	2-C8	230	5	GEAR, PRIMARY DRIVE .....	2-I1	319	3	HOLDER, CONTROL CABLE .....	2-B8	214	1
FLOAT SET .....	K5	147	3		2-I4	322	3		2-G3	289	19
	M4	178	3	GEAR, REDUCTION .....	2-E15	269	11	HOLDER, FUEL FILTER .....	2-D3	241	12
	M6	180	3	GOVERNOR ASSY. ....	G3	81	12		2-D12	250	11
	M13	187	3		G14	92	11	HOLDER, GOVERNOR WEIGHT .....	G5	83	14
	M16	190	2	GRID, AIR CLEANER .....	H1	95	5		G15	93	13
	N2	192	3	GRIP .....	2-B6	212	3		H1	95	7
FLYWHEEL COMP. ....	2-D15	253	5	GRIP, REINFORCEMENT .....	2-J4	338	5	HOLDER, LENS .....	2-J11	345	34
				GRIP, SCREW DRIVER .....	2-J6	340	9		2-J14	348	15
				GRIP, STARTER .....	J5	131	10	HOLDER, STOP SWITCH CORD .....	2-E5	259	13
	2-D16	254	7		2-K1	351	9		2-E10	264	6
				GROMMET, AIR CLEANER .....	N7	197	5		2-G12	298	18
	2-E1	255	11		N16	206	6		2-H1	303	10
					2-B2	208	5		2-H3	305	11
FUSE, BLADE .....	2-G15	301	31	GROMMET, CHOKE ROD .....	M9	183	27		2-H5	307	11
	2-H1	303	23	GROMMET, CORD .....	2-E4	258	7		2-H7	309	11
	2-H3	305	24		2-E9	263	6		2-H12	314	13
	2-H5	307	24					HOLDER, WIRE .....	L5	163	23
	2-H7	309	24						M5	179	19
	2-H10	312	16	GROMMET, CRANKCASE .....	2-J11	345	30		M16	190	17
	2-H13	315	23	GROMMET, DRAIN HOLE .....	J15	141	11		N2	192	22
	2-H14	316	13		K2	144	7		2-F13	283	21
				GROMMET, FENDER .....	M9	183	32		2-G3	289	22
	2-J7	341	22		2-B4	210	13	HOSE, AIR CLEANER .....	2-B6	212	7
	2-J11	345	28	GROMMET, MAIN CORD .....	2-J9	343	4				
	2-J15	349	19	GROMMET, SWITCH CORD .....	2-J9	343	5	HUB, CRAWLER SPROCKET .....	2-J16	350	1
				GROMMET, TUBE .....	2-J11	345	24				
				GROMMET, WIRE CORD .....	2-D13	251	13	[ I ]			
GASKET .....	2-D13	251	8	GUARD, FR. BATTERY .....	2-H15	317	11	INSULATOR .....	2-E16	270	15
GASKET KIT .....	2-K2	352	1	GUARD, RR. BATTERY .....	2-H15	317	12	INSULATOR, CARBURETOR .....	K16	158	17
GASKET SET .....	K3	145	1	GUIDE, CHOKE ROD .....	M9	183	28		L1	159	17
	M4	178	1	GUIDE, EX. VALVE .....	E2	48	3		M4	178	13
	M6	180	1	GUIDE, IN. VALVE .....	E2	48	2		M7	181	13
	M13	187	1	GUIDE, PRE AIR CLEANER .....	2-B1	207	12		M13	187	12
	M16	190	7	GUIDE, UNDER AIR .....	2-J6	340	1		M15	189	5
	N2	192	1						M16	190	12
GASKET, CYLINDER HEAD .....	E2	48	5						N2	192	14
	E3	49	5								
GASKET, EX. PIPE .....	2-B9	215	6								



# PART NAME INDEX

Part name	Address	Page	Ref.	Part name	Address	Page	Ref.	Part name	Address	Page	Ref.
[ J ]				LABEL, CAUTION .....	2-I7	325	7	MARK, AIR CLEANER SALES POINT ·	2-I15	333	15
JET SET, PILOT, .....	M1	175	37						2-J1	335	10
	M2	176	37		2-I14	332	2		2-J2	336	6
	M3	177	37		2-I15	333	12	MARK, CAUTION .....	2-I7	325	4
	M5	179	32		2-I16	334	3				5
	M12	186	51	LABEL, E-SPEC .....	2-J2	336	2				6
	M14	188	30		2-I10	328	28		2-I8	326	9
	N1	191	24		2-I11	329	28		2-I11	329	35
	N3	193	35		2-I13	331	17		2-I12	330	2
JET, MAIN, .....	L12	170	36		2-J1	335	12				3
	L13	171	36	LABEL, FUEL CAUTION .....	2-J3	337	11		2-I14	332	2
	L14	172	36		2-I10	328	26				3
	L15	173	36	LABEL, FUEL WARNING .....	2-J1	335	13		2-I16	334	2
	L16	174	36		2-I7	325	4				3
	M1	175	36	LABEL, FUSE .....	2-I12	330	2		2-J1	335	15
	M5	179	31	LABEL, SPECIFICATION .....	2-H14	316	8	MARK, CHOKE .....	2-J2	336	2
	M11	185	50		2-I9	327	14		2-I8	326	11
	M12	186	50		2-I12	330	8		2-I9	327	12
	M14	188	29		2-I13	331	8				13
	N1	191	23	LABEL, WARNING .....	2-J1	335	5		2-I11	329	31
	N3	193	34		2-I11	329	29		2-I12	330	6
JET, PILOT, .....	M15	189	11	LENS .....	2-I13	331	18				7
JOINT, FUEL .....	2-D12	250	2		2-J11	345	31		2-I14	332	4
JOINT, FUEL TANK .....	2-C14	236	2	LENS ASSY., PROTECTOR .....	2-J14	348	12				5
JOINT, ROD .....	M9	183	20		2-G13	299	20		2-I15	333	16
	M13	187	19		2-H1	303	12		2-I16	334	4
					2-H3	305	13		2-J1	335	16
					2-H5	307	13		2-J2	336	4
					2-H7	309	13	MARK, CONTROL BOX .....	2-G13	299	21
					2-J10	344	17		2-H5	307	14
					2-J14	348	11		2-H7	309	14
					L5	163	24		2-H9	311	11
				LEVER COMP., CHOKE .....	M5	179	20		2-H13	315	14
					M15	189	9	MARK, EMERGENCY SWITCH			
				LEVER COMP., THROTTLE .....	2-G7	293	2	INDICATION	2-I5	323	2
				LEVER, CHOKE .....	M8	182	19	MARK, EX. CAUTION .....	2-I9	327	22
				LEVER, CHOKE SOLENOID .....	N2	192	21		2-I10	328	23
				LEVER, COCK .....	M13	187	18		2-I11	329	33
					L5	163	26		2-I13	331	15
					L6	164	26		2-I14	332	8
					L7	165	26		2-J1	335	18
					M5	179	22	MARK, FUEL INDICATION .....	2-I10	328	25
					N2	192	23		2-I13	331	16
KEY, 6.3X6.3X33 .....	2-I2	320	10	LEVER, CONTROL .....	2-F8	278	11	MARK, OIL ALERT .....	2-I9	327	15
	2-I4	322	7		2-G3	289	12				16
KEY, 6.3X6.3X43 .....	H5	99	12	LIFTER, VALVE .....	18	118	4				18
KEY, 7X7X33 .....	H5	99	12						2-I10	328	26
	2-I2	320	10						2-I13	331	10
KEY, 7X7X40 .....	2-I2	320	10								11
KEY, SPECIAL WOODRUFF, 25X18 ·	2-E1	255	10	[ M ]				MARK A, COMBINATION .....	2-I12	330	4
KNOB, COCK LEVER .....	2-J9	343	10	MARK B, COMBINATION .....	2-I12	330	5		2-I14	332	6
	2-J14	348	4	MARK, AIR CLEANER .....	2-I9	327	19		2-I15	333	9
					2-I11	329	32		2-J1	335	6
					2-I13	331	12				7
					2-I14	332	7				8
					2-J1	335	17		2-J2	336	5
LABEL, AIR CLEANER CAUTION ...	2-I9	327	20	MARK, AIR CLEANER CAUTION .....	2-I8	326	10	MARK, OIL CAUTION .....	2-I10	328	27
	2-I15	333	14		2-I9	327	21		2-I13	331	8
	2-J1	335	9						2-I14	332	9
	2-J2	336	7						2-J1	335	19



# PART NAME INDEX

Part name	Address	Page	Ref.	Part name	Address	Page	Ref.	Part name	Address	Page	Ref.
MARK, OIL CAUTION .....	2-J3	337	10	NUT, FLANGE, 8MM .....	2-C11	233	11	PACKING, AIR CLEANER.....	2-B6	212	1
MARK, OPERATOR CAUTION .....	2-I7	325	6		2-D4	242	15	PACKING, AIR CLEANER COVER.....	N16	206	4
					2-D12	250	15	PACKING, CARBURETOR.....	L2	160	19
MARK, THROTTLE INDICATION .....	2-I9	327	17		2-J15	349	27		L3	161	19
	2-I15	333	17	NUT, HEX., 3MM .....	M14	188	26		M4	178	15
	2-J1	335	14	NUT, HEX., 4MM .....	2-G15	301	29		M7	181	14
	2-J3	337	12		2-H1	303	21		M13	187	13
METER ASSY., FUEL .....	2-D9	247	7		2-H3	305	22		M15	189	7
	2-J12	346	7		2-H5	307	22		M16	190	13
MOTOR UNIT, STARTER .....	2-E13	267	4		2-H7	309	22		N2	192	15
MUFFLER COMP. ....	2-B9	215	2		2-H10	312	14	PACKING, CASE COVER.....	F15	77	3
	2-B12	218	2		2-H13	315	21		G13	91	3
	2-C8	230	1	NUT, HEX., 5MM .....	2-B11	217	19		H1	95	3
	2-C10	232	1		2-C5	227	25	PACKING, CHAIN CASE COVER.....	2-I1	319	2
	2-C12	234	1	NUT, HEX., 8MM .....	2-C12	234	7		2-I4	322	2
				NUT, OIL FILLER .....	G7	85	17	PACKING, ELBOW.....	N4	194	1
[ N ]					G15	93	17		N15	205	1
				NUT, PIVOT ADJUSTING .....	I9	119	16		N16	206	1
NOSE, SILENCER .....	N8	198	6	NUT, RING.....	2-D13	251	7		2-B2	208	1
	N9	199	6	NUT, SELF-LOCK, 6MM .....	2-F15	285	26	PACKING, FUEL COCK.....	L9	167	29
	2-B2	208	6		2-G4	290	27		M5	179	25
NOZZLE, MAIN .....	K13	155	14	NUT, SPECIAL, 16MM .....	2-D16	254	9		N3	193	27
	K14	156	14		2-E1	255	9	PACKING, FUEL FILLER CAP.....	2-D2	240	8
	K15	157	14	NUT, TOOL BOX SETTING .....	N12	202	12		2-D3	241	9
	M4	178	12		N13	203	12		2-D8	246	30
	M7	181	12		N15	205	10		2-D10	248	10
	M13	187	11		2-B1	207	16		2-D12	250	7
	M16	190	10		2-B2	208	12				8
	N2	192	11		2-B6	212	11		2-J12	346	10
NUT-WASHER, 6MM .....	2-F2	272	21		2-B8	214	11	PACKING, FUEL STRAINER CUP.....	K16	158	16
NUT, AIR CLEANER COVER .....	N11	201	11	NUT, WING, 6MM .....	N11	201	11		N2	192	13
	N15	205	9		N15	205	9		2-D7	245	19
	2-B1	207	15		2-B1	207	15		2-D9	247	1
	2-B2	208	11		2-B2	208	11		2-J12	346	1
NUT, BATTERY TERMINAL .....	2-H15	317	10	[ O ]				PACKING, HEAD COVER.....	E5	51	7
NUT, CAP, 6MM .....	N11	201	10					PACKING, INSULATOR .....	L3	161	20
	N15	205	8	OIL SEAL, 24X47X15 .....	2-J16	350	5		L4	162	20
	2-B1	207	14	OIL SEAL, 30X46X8 .....	2-I3	321	12		M4	178	16
	2-B2	208	10		2-I4	322	9		M5	179	16
NUT, FLANGE, 10MM .....	F9	71	16	OIL SEAL, 35X52X8 .....	F7	69	11		M8	182	15
NUT, FLANGE, 5MM .....	2-B4	210	15		G9	87	21		M13	187	14
NUT, FLANGE, 6MM .....	M11	185	40		H1	95	13		M15	189	8
	M14	188	27	OIL SEAL, 8X14X5 .....	2-I3	321	12		M16	190	14
	N14	204	14	O-RING .....	F8	70	12	PACKING, OIL FILLER CAP.....	N2	192	16
	N15	205	12		2-D7	245	22		G1	79	8
	2-B1	207	18	O-RING, 14MM .....	2-D9	247	4		G2	80	9
	2-B2	208	10		2-J12	346	4		G3	81	10
	2-B5	211	16		F9	71	13		G14	92	7
	2-B6	212	14	O-RING, 16MM .....	2-D3	241	13				8
	2-B8	214	15	O-RING, 26X2.7 .....	2-D12	250	14		G16	94	30
	2-G1	287	33		G15	93	21	PANEL COMP., CONTROL.....	2-J15	349	24
	2-G5	291	39		H1	95	14		2-G11	297	8
	2-G6	292	13						2-G16	302	4
NUT, FLANGE, 8MM .....	2-B6	212	15	[ P ]					2-H2	304	5
	2-B11	217	23	PACKING .....	2-F1	271	18		2-H4	306	5
	2-C6	228	29	PACKING, AIR CLEANER .....	M9	183	24		2-H6	308	4
	2-C9	231	10		M13	187	24		2-H7	309	4
									2-H9	311	4
	2-C11	233	10						2-H12	314	6

# PART NAME INDEX

Part name	Address	Page	Ref.	Part name	Address	Page	Ref.	Part name	Address	Page	Ref.
PANEL, CONTROL BOX .....	2-G13	299	21	PLUG, SPARK .....	E13	59	19	ROD ASSY., CONNECTING.....	I3	113	4
	2-H1	303	13		E14	60	19		I4	114	4
	2-H3	305	14		E15	61	19		I5	115	4
	2-H5	307	14		2-J5	339	14	ROD, CHOKE .....	M9	183	21
PAN, CLEANER OIL .....	N15	205	5	PLUG, USELESS HOLE .....	K1	143	22		N2	192	18
PIN, FLAT, 6X27.5 .....	2-J7	341	9	PROTECTOR COMP., FAN COVER .....	J13	139	4	ROD, CHOKE CONTROL .....	M9	183	26
PIN, GOVERNOR WEIGHT .....	G5	83	15		K2	144	5	ROD, CHOKE SOLENOID .....	M13	187	20
	G15	93	14	PROTECTOR COMP., MUFFLER .....	2-B9	215	3	ROD, GOVERNOR .....	2-F4	274	3
	H1	95	8		2-B13	219	3		2-F5	275	3
PIN, LOCK, 10MM .....	F11	73	18	PROTECTOR, CIRCUIT .....	2-G13	299	19		2-G2	288	3
PIN, LOCK, 6MM .....	2-J7	341	12		2-H1	303	11		2-G6	292	2
PIN, LOCK, 8MM .....	F10	72	18		2-H3	305	12	ROD, PUSH .....	I8	118	2
	2-D12	250	16		2-H5	307	12	ROPE, RECOIL STARTER.....	J6	132	11
	2-J5	339	13		2-H7	309	12		2-K1	351	10
PIN, PISTON .....	I3	113	3		2-J10	344	16	ROTATOR, VALVE .....	I9	119	13
PIN, ROLLER ARM, 8X22 .....	2-J5	339	12		2-J14	348	10	RUBBER, AIR CLEANER COVER.....	2-B8	214	6
PIN, SPRING, 2X12 .....	L12	170	35	PROTECTOR, EX. PIPE .....	2-B13	219	4	RUBBER, BOTTOM .....	F5	67	5
	M5	179	30	PROTECTOR, L. MUFFLER .....	2-C8	230	3				6
	M15	189	10	PROTECTOR, MUFFLER INNER .....	2-C10	232	3	RUBBER, CONTROL .....	2-J15	349	25
PIN, SPRING, 2X6 .....	2-G7	293	6	PROTECTOR, MUFFLER OUTER .....	2-C10	232	2		2-J9	343	3
PIPE COMP., OIL .....	G3	81	11	PROTECTOR, R. MUFFLER .....	2-C8	230	2	RUBBER, CONTROL BOX .....	2-J11	345	21
PIPE, BOX WRENCH EXTENSION ...	2-J5	339	11	PULLEY COMP., STARTER .....	2-D14	252	3	RUBBER, FUEL .....	2-D7	245	27
	2-J7	341	8	PULLEY, RECOIL STARTER .....	I15	125	3		2-D10	248	16
PIPE, EX. ....	2-B9	215	4		2-K1	351	3		2-J12	346	17
	2-B14	220	5	PULLEY, STARTER .....	2-D15	253	4	RUBBER, SUPPORTER .....	2-C13	235	1
	2-C8	230	4						2-D11	249	22
	2-C10	232	5	[ R ]				RUBBER, TANK CUSHION.....	2-D12	250	1
PISTON .....	H15	109	2	RATCHET, STARTER .....	I16	126	4		2-D10	248	15
	H16	110	2		2-K1	351	4		2-D12	250	12
	I1	111	2	RECTIFIER ASSY., REGULATOR ....	2-E11	265	11	RUBBER, TANK MOUNTING.....	2-J12	346	16
	I2	112	2		2-G8	294	2		2-D7	245	26
	I3	113	2		2-G11	297	9		2-D10	248	12
PIVOT, ROCKER ARM .....	I8	118	5		2-H9	311	5		2-J12	346	12
PLATE SET, AIR CLEANER .....	2-B7	213	19		2-H11	313	2	[ S ]			
PLATE, BATTERY .....	2-H15	317	4		2-H12	314	7	SCREEN SET .....	2-D12	250	3
PLATE, BATTERY GUARD .....	2-H15	317	1		2-J15	349	21	SCREEN, FUEL STRAINER.....	2-D7	245	21
PLATE, BATTERY SETTING .....	2-H15	317	2	RECTIFIER ASSY., SILICON .....	2-G11	297	10		2-D9	247	3
	2-H16	318	2		2-G16	302	5		2-J12	346	3
PLATE, COOLING FAN SETTING ...	2-D14	252	2		2-H2	304	6	SCREW-WASHER, 4X6 .....	2-F1	271	16
PLATE, EXTENSION .....	G14	92	10		2-H5	307	6	SCREW-WASHER, 5X12 .....	M10	184	39
PLATE, FUEL INDICATION .....	2-I10	328	24		2-H7	309	5		M11	185	39
	2-I13	331	16		2-J9	343	6		M13	187	25
	2-I15	333	13		2-J14	348	2		N1	191	20
PLATE, FUEL TANK HANGER .....	2-D13	251	14	RECTIFIER COMP., REGULATOR ....	2-J11	345	35		2-B11	217	20
PLATE, LEVER SETTING .....	L7	165	27	RECTIFIER COMP., SILICON .....	2-H14	316	3		2-C5	227	27
	M5	179	23	RETAINER, EX. VALVE SPRING ....	I9	119	11	SCREW-WASHER, 5X14 .....	2-F1	271	19
	N3	193	24	RETAINER, IN. VALVE SPRING ....	I9	119	10	SCREW-WASHER, 5X16 .....	L11	169	34
PLATE, PUSH ROD GUIDE .....	I9	119	14	RETAINER, SPRING .....	J4	130	8		M5	179	29
PLATE, SET .....	2-B10	216	13		2-K1	351	8		2-B8	214	14
	2-C3	225	17	RING SET, PISTON .....	H6	100	1		2-F16	286	32
PLUG, CONE TYPE .....	2-B8	214	12		H7	101	1		2-G5	291	38
PLUG, OIL DRAIN .....	F13	75	23		H8	102	1	SCREW-WASHER, 5X32 .....	2-F1	271	20
	2-J15	349	17		H9	103	1	SCREW-WASHER, 6X20 .....	2-B11	217	21
PLUG, SEALING .....	F7	69	10		H10	104	1		2-C5	227	28
PLUG, SEAL, 47X10 .....	2-J16	350	6		H11	105	1	SCREW SET .....	K7	149	6
PLUG, SPARK .....	E9	55	19		H12	106	1		K9	151	9
	E10	56	19		H13	107	1		M4	178	8
	E11	57	19		H14	108	1				
	E12	58	19								



# PART NAME INDEX

Part name	Address	Page	Ref.	Part name	Address	Page	Ref.	Part name	Address	Page	Ref.
SCREW SET .....	M7	181	8	SCREW, PAN, 5X35 .....	2-G5	291	37	SOLENOID ASSY. ....	2-G7	293	3
	M13	187	7	SCREW, PAN, 5X45 .....	2-F16	286	31	SOLENOID ASSY., CHOKE .....	M13	187	21
	M16	190	6		2-G1	287	32	SOLENOID, ROTARY CHOKE .....	M13	187	23
	N2	192	7	SCREW, PAN, 5X8 .....	2-G7	293	5	SPACER COMP., CARBURETOR .....	L2	160	18
SCREW SET, DRAIN .....	K9	151	8	SCREW, PAN, 6X6 .....	2-C5	227	26		M4	178	14
	M4	178	7	SCREW, PAN, 6X8 .....	2-B8	214	13		M15	189	6
	M7	181	7	SCREW, RECESSED, 5X25 .....	2-F15	285	25	SPACER, CHOKE SOLENOID .....	M13	187	22
	M13	187	6	SCREW, SPECIAL, 6X12 .....	2-G13	299	23	SPACER, CONTROL LEVER .....	2-F11	281	15
	M16	190	5		2-H1	303	15		2-G3	289	16
	N2	192	6		2-H3	305	16	SPACER, MUFFLER COVER .....	2-B10	216	14
SCREW SET, PILOT .....	K7	149	6		2-H5	307	16		2-C3	225	18
	K8	150	7		2-H7	309	16	SPANNER, 10X12 .....	2-J5	339	15
	M4	178	6		2-H9	311	12		2-J6	340	7
	M6	180	5		2-H13	315	16		2-J7	341	14
			6	SCREW, TAPPING, 4X6 .....	2-B11	217	17		2-J8	342	11
	M13	187	5				18	SPANNER, 10X14 .....	2-J5	339	16
	M16	190	3		2-C4	226	24		2-J7	341	23
	N2	192	5		2-C9	231	13	SPANNER, 12X14 .....	2-J7	341	21
SCREW, CENTER .....	J7	133	13	SCREW, TAPPING, 4X8 .....	2-C11	233	9	SPANNER, 14X17 .....	2-J5	339	17
	2-K1	351	11	SCREW, TAPPING, 5X25 .....	2-B11	217	16		2-J8	342	12
SCREW, FLAT, 5X10 .....	2-D3	241	14		2-C4	226	23	SPRING, BRUSH RETURN .....	2-E15	269	10
	2-D11	249	18	SCREW, TAPPING, 5X8 .....	2-B10	216	15	SPRING, CABLE RETURN .....	2-F13	283	20
	2-J13	347	19		2-B11	217	18		2-G3	289	21
SCREW, GLOVE BOX .....	2-J10	344	19		2-C3	225	20	SPRING, CHOKE RETURN .....	2-G7	293	1
	2-J14	348	16		2-C4	226	22	SPRING, COCK LEVER .....	L8	166	28
SCREW, PAN, 3X12 .....	2-G14	300	27		2-C9	231	9		M5	179	24
	2-H1	303	19				15		N3	193	26
	2-H3	305	20	SCREW, TAPPING, 6X10 .....	2-B11	217	22	SPRING, COIL .....	2-J11	345	33
	2-H5	307	20	SCREW, THROTTLE STOP .....	K13	155	13		2-J14	348	14
	2-H7	309	20		M4	178	11	SPRING, CONTROL ADJUSTING .....	K2	144	2
SCREW, PAN, 3X6 .....	L11	169	32		M7	181	10		2-F12	282	19
	M5	179	27		M13	187	9		2-G3	289	20
	N3	193	32		M15	189	3	SPRING, CONTROL LEVER RETURN ..	2-G6	292	7
SCREW, PAN, 3X8 .....	L10	168	32		M16	190	9	SPRING, FRICTION .....	2-G6	292	8
	M5	179	27		N2	192	9		J1	127	5
SCREW, PAN, 4X12 .....	2-G15	301	28	SCROLL, GENERATOR FAN .....	K2	144	1	SPRING, GOVERNOR .....	2-K1	351	5
	2-H1	303	20	SEAL, AIR CLEANER .....	2-B4	210	11		2-F5	275	4
	2-H3	305	21	SEAL, CHOKE LEVER .....	M10	184	34	SPRING, LEVER .....	2-G2	288	4
	2-H5	307	21	SEAL, FAN COVER .....	K1	143	19		2-G6	292	3
	2-H7	309	21	SEAL, FUEL FILLER NECK .....	2-D13	251	11	SPRING, LEVER .....	2-F9	279	12
	2-H10	312	13	SEAL, MUFFLER DUCT .....	2-C12	234	3		2-G3	289	13
	2-H13	315	20				4	SPRING, MANUAL CHOKE .....	M9	183	23
SCREW, PAN, 4X25 .....	2-B6	212	13				5	SPRING, RATCHET .....	J3	129	7
SCREW, PAN, 4X6 .....	L11	169	33	SEAL, MUFFLER PROTECTOR .....	2-C10	232	4		2-K1	351	7
	M5	179	28	SEAL, RECOIL .....	K1	143	20	SPRING, RETURN .....	L5	163	25
	N3	193	33	SEAL, UNDER AIR GUIDE .....	2-J6	340	2		M5	179	21
	2-F15	285	28	SEAL, VALVE STEM .....	I10	120	17		M16	190	16
	2-G5	291	35	SEAT, VALVE SPRING .....	I9	119	12	SPRING, STARTER RETURN .....	J2	128	6
SCREW, PAN, 5X12 .....	M10	184	38	SEPARATOR, AIR CLEANER .....	2-B3	209	4		2-K1	351	6
SCREW, PAN, 5X16 .....	2-G1	287	32	SHAFT, GOVERNOR ARM .....	F4	66	3	SPRING, THROTTLE RETURN .....	N2	192	19
	2-G5	291	38	SHAFT, P.T.O. ....	2-I1	319	6		2-F6	276	5
SCREW, PAN, 5X16.5 .....	2-B1	207	13		2-I4	322	5		2-G2	288	5
SCREW, PAN, 5X32 .....	K2	144	10	SHROUD .....	J13	139	5		2-G6	292	4
	2-F15	285	29	SHROUD ASSY., UPPER .....	K2	144	3	SPRING, VALVE .....	I9	119	9
	2-G4	290	28	SHROUD COMP., LOWER .....	K2	144	6	SPRING, WEIGHT RETURN .....	I9	119	6
	2-G5	291	36	SLIDER, GOVERNOR .....	G6	84	16	STARTER ASSY., RECOIL .....	I11	121	1
	2-G6	292	12		G7	85	16		I12	122	1
SCREW, PAN, 5X35 .....	2-F16	286	30		G15	93	15		I13	123	1
	2-G4	290	28		H1	95	9		2-K1	351	1

# PART NAME INDEX

Part name	Address	Page	Ref.	Part name	Address	Page	Ref.	Part name	Address	Page	Ref.
STAY ASSY., CHOKE CONTROL ----	L4	162	22	[ T ]				TUBE, FUEL, 5.3X200.....	2-D5	243	16
	M5	179	18	TANK ASSY., FUEL .....	2-C14	236	3	TUBE, FUEL, 5.3X240.....	2-D5	243	16
	M16	190	15		2-C15	237	3	TUBE, VINYL, 4.5X8X230.....	2-B5	211	18
	N2	192	20	TANK COMP., FUEL .....	2-C15	237	5	TUBE, VINYL, 4.5X8X380.....	2-B5	211	19
STAY ASSY., MANUAL CHOKE .....	M8	182	17		2-C16	238	5	[ V ]			
STAY ASSY., SOLENOID .....	M13	187	16		2-D1	239	5	VALVE ASSY., SOLENOID.....	M8	182	16
STAY A, MUFFLER .....	2-C11	233	7		2-D7	245	25		M9	183	30
STAY COMP., AIR CLEANER .....	2-B6	212	5		2-D9	247	8		M13	187	15
STAY COMP., CHOKE SOLENOID ...	M13	187	17		2-D10	248	8		M16	190	11
STAY COMP., SOLENOID .....	M8	182	18		2-D12	250	4	VALVE SET, FLOAT.....	K4	146	2
STAY COMP., WIRE HOLDER .....	2-B8	214	3		2-J12	346	8		M4	178	2
STAY, AIR CLEANER .....	2-B3	209	6	TERMINAL ASSY., HIGH TENSION --	2-E3	257	2		M6	180	2
STAY, MUFFLER COVER .....	2-B10	216	12		2-E10	264	4		M13	187	2
	2-C3	225	16	TIMER UNIT .....	2-H14	316	7		M16	190	1
STOPPER, CHOKE ROD .....	M9	183	22	TOOL KIT .....	2-J4	338	2		N2	192	2
STOPPER, DISCHARGE GUARD .....	2-D10	248	13		2-J6	340	3	VALVE, DASHPOT CHECK.....	M9	183	29
	2-J12	346	13	TOOL SET .....	2-J8	342	3	VALVE, EX. ....	I9	119	8
STRAINER, FUEL .....	2-D13	251	6		2-J7	341	19	VALVE, IN. ....	I9	119	7
STRAP, CABLE, 118MM .....	2-G14	300	25	TUBE, 11X105 .....	2-J7	341	19	[ W ]			
	2-H1	303	17	TUBE, 3.5X130 .....	E8	54	17	WASHER COMP., HEAD COVER.....	E7	53	14
	2-H3	305	18	TUBE, 3.5X30 .....	M11	185	48	WASHER, 10.5X40X4.....	H5	99	10
	2-H5	307	18	TUBE, 3.5X495 .....	M11	185	48		2-I2	320	9
	2-H7	309	18	TUBE, 3.5X695 .....	M11	185	49	WASHER, 6X16.....	G7	85	18
	2-H13	315	18	TUBE, 3.5X75 .....	M11	185	47		G15	93	18
STRAP, WIRE HARNESS, 25MM ----	2-H14	316	10	TUBE, BATTERY BREATHER .....	2-H16	318	1		H1	95	10
	2-J6	340	6	TUBE, BREATHER .....	E5	51	8	WASHER, 8MM.....	2-I2	320	8
SUB HARNESS .....	F5	67	4		E8	54	17		2-I4	322	6
	J14	140	9		E15	61	20	WASHER, 8.2X17X0.8.....	F6	68	9
	2-G11	297	14					WASHER, AIR DUCT.....	2-D12	250	13
	2-H5	307	27	TUBE, CORD .....	2-B3	209	1		2-J10	344	20
	2-H7	309	7		2-J8	342	8	WASHER, CHOKE LEVER.....	M10	184	33
	2-H9	311	7	TUBE, FASTENER, 30MM .....	2-J11	345	22	WASHER, CONTROL LEVER.....	2-F9	279	13
	2-H12	314	9		2-G14	300	26		2-G3	289	14
SUSPENSION, COUPLER .....	2-G11	297	13		2-H1	303	18	WASHER, DRAIN PLUG, 12MM.....	F9	71	17
	2-G16	302	6		2-H3	305	19		2-J15	349	20
	2-H2	304	7	TUBE, FUEL .....	2-H5	307	19	WASHER, FRAME JOINT.....	2-J13	347	23
	2-H5	307	7		2-H7	309	19	WASHER, LOCK, 8MM.....	H5	99	11
	2-H7	309	6		2-H13	315	19		2-I2	320	9
SUSPENSION, WINKER RELAY .....	2-H14	316	6		2-D13	251	1	WASHER, PLAIN, 4MM.....	2-G15	301	33
	2-J7	341	20	TUBE, FUEL SUPPORTER .....	2-D7	245	28		2-H3	305	26
SWITCH ASSY., COMBINATION ----	2-G11	297	16	TUBE, FUEL, 4.5X150 .....	2-D11	249	19		2-H5	307	25
	2-G12	298	16		2-J13	347	20		2-H8	310	26
	2-G16	302	8	TUBE, FUEL, 4.5X165 .....	2-D7	245	28		2-H13	315	25
	2-H2	304	9		2-D11	249	19	WASHER, PLAIN, 5MM .....	M11	185	41
	2-H5	307	9	TUBE, FUEL, 4.5X190 .....	2-J13	347	20		2-B11	217	24
	2-H7	309	9		2-D11	249	19		2-C6	228	30
	2-H9	311	9	TUBE, FUEL, 4.5X210 .....	2-D11	249	19	WASHER, PLAIN, 6MM.....	2-G5	291	40
	2-H12	314	11	TUBE, FUEL, 4.5X235 .....	2-D5	243	16		G10	88	22
	2-J9	343	11	TUBE, FUEL, 4.5X250 .....	2-D11	249	19		G15	93	22
	2-J10	344	11	TUBE, FUEL, 4.5X260 .....	N1	191	21		H1	95	15
	2-J11	345	36		2-D11	249	19		2-B6	212	16
	2-J14	348	5	TUBE, FUEL, 4.5X300 .....	2-D11	249	19	WASHER, PLAIN, 8MM .....	2-C11	233	12
SWITCH ASSY., ENGINE KILL ----	2-J10	344	14	TUBE, FUEL, 4.5X430 .....	2-D5	243	16	WASHER, SPRING, 3MM.....	M14	188	28
	2-J14	348	8		2-D12	250	17	WASHER, SPRING, 4MM.....	2-G15	301	30
SWITCH ASSY., ENGINE STOP ----	J14	140	10								
	J15	141	10								
SWITCH ASSY., OIL LEVEL .....	F3	65	2								
SWITCH ASSY., STARTER MAGNETIC	2-J15	349	22								
SWITCH, THERMO .....	E5	51	9								



# PART NAME INDEX

**2-M10**

Part name	Address	Page	Ref.	Part name	Address	Page	Ref.	Part name	Address	Page	Ref.
WASHER, SPRING, 4MM .....	2-H1	303	22								
	2-H3	305	23								
	2-H5	307	23								
	2-H7	309	23								
	2-H10	312	15								
	2-H13	315	22								
WASHER, SPRING, 5MM .....	2-B11	217	25								
	2-C7	229	31								
WASHER, TANK CUSHION .....	2-D10	248	14								
	2-J12	346	15								
WASHER, THRUST, 2.7X8 .....	M10	184	35								
WEIGHT, BALANCER .....	H5	99	8								
WEIGHT, GOVERNOR .....	G4	82	13								
	G14	92	12								
	H1	95	6								
WHEEL, DRIVEN .....	2-J16	350	3								
WHEEL, DRIVE SPROCKET .....	2-J16	350	2								
WHEEL, INDUCTION .....	2-J16	350	4								
WIRE, WATER COVER .....	2-E15	269	13								
	2-E16	270	14								
WRENCH COMP., SPARK PLUG .....	2-J1	335	11								
	2-J4	338	9								
	2-J7	341	6								
	2-J8	342	5								
WRENCH, BOX .....	2-J4	338	8								
	2-J5	339	18								
	2-J6	340	10								
	2-J7	341	17								
WRENCH, PLUG .....	2-J4	338	7								
	2-J6	340	5								
	2-J7	341	5								
	2-J8	342	4								
[ Y ]											
YOKE COMP. ....	2-E15	269	9								



---

**1**

**FOREWORD INDEX**

---

**2**

**ENGINE GROUP**

---

**3**

**PART NUMBER INDEX**

---

**4**

**PART NAME INDEX**

---





**HONDA**  
The Power of Dreams



# PARTS CATALOGUE NEWS

Honda Motor Co., Ltd. Service Division

## PARTS CATALOGUE - CORRECTED

Printed in Japan

CODE NO.	17ZE30E9
PARTS CATALOGUE NEWS	GX340K1 GX340K1 [PROPANE ENGINE]
NEWS NO.	001

Block No.	Ref. No.	Note	Part No.	Description	Reqd. QTY			Serial No.	Parts catalogue code	
					(1)	(2)	(3)			
E-28	18		87532-ZH8-810	MARK, OIL ALERT (ENGLISH) ....	1	1	1	-----	EDN5, EDN5/A, ED9, HX26, HX26/A, LKE/A, LXE6, LXE8, LXE8/A, LXU, LXU/A, LX26, LX26/A, PXE8, PXE8/A, P1/A, QAE6, QAE6/A, QA26, QA26/A, QME8, QME8/A, QNE6, QNR6, QNR6/A, QXC6, QXC6/A, QXE6, QXE6/A, QXE8, QXE8/A, QXU, QXU/A, Q1/A, SHT, SWX/A, SXE8, SXE8/A, SXU, SXU/A, VD16, VEB6, VMX, VXB2, VXE6, VXE8, VXE8/A, VXP, VXU, VXU1, VXU1/A, VX16, VX16/A, VX8, VX8/A	
					1	1	-	-----	4110467	ED9/A, ES1/A, ES2, LXE/A, L1/A, PX/A, QX/A, QXE/A, SX/A, SXE/A, S1/A, VX/A, VXU/A
					1	1	-	2143684	-----	ES1, HX, LKE, LXE, LXZ, L1, PX, P1, QX, QXE, QXEB, Q1, SWX, SX, SXE, S1, VAA, VAAE, VNG, VX, V1
					1	-	-	2338523	-----	VXG
					1	-	-	2143684	2338523	-----
	A		87530-ZL8-850	.....	1	1	-	4110468	-----	ED9/A, ES1/A, ES2, LXE/A, L1/A, PX/A, QX/A, QXE/A, SX/A, SXE/A, S1/A, VX/A, VXU/A
E-28-3	8		87532-ZH8-810	MARK, OIL ALERT (ENGLISH) ....	1	-	-	-----	-----	HAQ, HA2, HA2/A, HX2, LX2, LX2/A, QAE2, QAP2, QAQ, QA2, QNE2, QNE9, QNE9/A, QN18, QPE2, QXC/A, QXC9, QXE2, QX2, VAW1, VA2, VA2/A, VDE, VWE, VXE2, VXE2/A
					1	-	-	3930787	-----	QAE2/A, QAP2/A, QA2/A, QNE2/A, QXC9/A
					1	-	-	4110467	-----	LX/A, VXE/A
					1	-	-	2143684	-----	HA, LX, QA, QAE, QAP, QAPE, QNE, QXC, SXP, VA, VXA, VXE

NOTE A:PART NO. CHANGE D:NEWLY PROVIDED E:PART NO. DELETION K:REQUIRED NO. CORRECTION L:APPLICATION SERIAL NO. CORRECTION  
T:APPLICATION CORRECTION Z:REMARKS CHANGE

PARTS CATALOGUE NEWS

BOOKNo. : 17ZE30E9

Block No.	Ref. No.	Note	Part No.	Description	Reqd. QTY			Serial No.	Parts catalogue code
					(1)	(2)	(3)		
		A	87530-ZL8-850	.....	1	-	-	4110468 -----	LX/A, VXE/A

NOTE A:PART NO. CHANGE D:NEWLY PROVIDED E:PART NO.DELETION K:REQUIRED NO. CORRECTION L:APPLICATION SERIAL NO. CORRECTION  
 T:APPLICATION CORRECTION Z:REMARKS CHANGE



# PARTS CATALOGUE NEWS

Honda Motor Co., Ltd. Service Division

## PARTS CATALOGUE - CORRECTED

Printed in Japan

CODE NO.	17ZE30E9
PARTS CATALOGUE NEWS	GX340K1 GX340K1 [PROPANE ENGINE]
NEWS NO.	002

Block No.	Ref. No.	Note	Part No.	Description	Reqd. QTY			Serial No.	Parts catalogue code	
					(1)	(2)	(3)			
E-16-3	1		18310-ZD1-E31	MUFFLER COMP. ....	1	-	-	-----	EDS, EDS1, EDS2, EDS2/A, EDS3, EDS6, EDS6/A, EDT, EDT/A, EDT1, EDT2, EDT6, EDT6/A, EMT, ES3, ES4, VAA, VAAE, VMT	
					1	-	-	-----	2374605	ED6
					1	-	-	-----	4115280	EDS1/A, EDS4, EDT1/A, EDT3, EMT/A, ES3/A, ES4/A, VMQ, VMT/A
					1	-	-	-----	4114698	VS2, VS3, VS4, VS5, VS6, VS7
			18310-ZE2-V60	MUFFLER COMP. (TSURUMI) .....	1	-	-	-----	ED6/A, ENT, ENT/A, ENT2, EN6, EN6/A, VTE2	
					1	-	-	-----	2374606	ED6
					1	-	-	-----	4115281	EDS1/A, EDS4, EDT1/A, EDT3, EMT/A, ES3/A, ES4/A, VMQ, VMT/A
A	18310-ZD1-E32	MUFFLER COMP. ....	1	-	-	4115281	-----	EDS1/A, EDS4, EDT1/A, EDT3, EMT/A, ES3/A, ES4/A, VMQ, VMT/A		
A	18310-ZE2-V61	MUFFLER COMP. (TSURUMI) .....	1	-	-	4114699	-----	VS2, VS3, VS4, VS5, VS6, VS7		

NOTE A:PART NO. CHANGE D:NEWLY PROVIDED E:PART NO.DELETION K:REQUIRED NO. CORRECTION L:APPLICATION SERIAL NO. CORRECTION  
T:APPLICATION CORRECTION Z:REMARKS CHANGE



# PARTS CATALOGUE NEWS

Honda Motor Co., Ltd. Service Division

## PARTS CATALOGUE - CORRECTED

Printed in Japan

CODE NO.	17ZE30E9
PARTS CATALOGUE NEWS	GX340K1 GX340K1 [PROPANE ENGINE]
NEWS NO.	003

Block No.	Ref. No.	Note	Part No.	Description	Reqd. QTY			Serial No.	Parts catalogue code
					(1)	(2)	(3)		
E-3	2		15510-ZE2-053	SWITCH ASSY., OIL LEVEL .....	1	-	-	----- 4121257	EDT3, ES2, VS2, VS7
					1	-	-	4074479 4121257	EDK, EDS1/A, EDS4, EDT1/A, ED9/A, EMT/A, ES1/A, ES3/A, ES4/A, LX/A, LXE/A, PX/A, QX/A, QXE/A, STJ/A, SX/A, SXE/A, VMQ, VMT/A, VS3, VS4, VS5, VS6, VX/A, VXE/A, VXX, VXU/A
					-	(1)	-	4074479 -----	L1/A, S1/A
	A		35480-ZF6-003	.....	1	-	-	4121258 -----	EDK, EDS1/A, EDS4, EDT1/A, EDT3, ED9/A, EMT/A, ES1/A, ES2, ES3/A, ES4/A, LX/A, LXE/A, PX/A, QX/A, QXE/A, STJ/A, SX/A, SXE/A, VMQ, VMT/A, VS2, VS3, VS4, VS5, VS6, VS7, VX/A, VXE/A, VXX, VXU/A

NOTE A:PART NO. CHANGE D:NEWLY PROVIDED E:PART NO.DELETION K:REQUIRED NO. CORRECTION L:APPLICATION SERIAL NO. CORRECTION  
T:APPLICATION CORRECTION Z:REMARKS CHANGE



# PARTS CATALOGUE NEWS

Honda Motor Co., Ltd. Service Division

## PARTS CATALOGUE - CORRECTED

Printed in Japan

CODE NO.	17ZE30E9
PARTS CATALOGUE NEWS	GX340K1 GX340K1 [PROPANE ENGINE]
NEWS NO.	004

Block No.	Ref. No.	Note	Part No.	Description	Reqd. QTY			Serial No.	Parts catalogue code
					(1)	(2)	(3)		
E-8	1	A	13010-Z5N-003	RING SET, PISTON (STD.) (RIKEN)	1	-	-	-----	ES2
		A	13011-Z5N-003	RING SET, PISTON (0.25) (RIKEN)	(1)	-	-	-----	ES2
		A	13012-Z5N-003	RING SET, PISTON (0.50) (RIKEN)	(1)	-	-	-----	ES2
		A	13013-Z5N-003	RING SET, PISTON (0.75) (RIKEN)	(1)	-	-	-----	ES2

NOTE A:PART NO. CHANGE D:NEWLY PROVIDED E:PART NO.DELETION K:REQUIRED NO. CORRECTION L:APPLICATION SERIAL NO. CORRECTION  
T:APPLICATION CORRECTION Z:REMARKS CHANGE



# PARTS CATALOGUE NEWS

Honda Motor Co., Ltd. Service Division

## PARTS CATALOGUE - CORRECTED

Printed in Japan

CODE NO.	17ZE30E9
PARTS CATALOGUE NEWS	GX340K1 GX340K1 [PROPANE ENGINE]
NEWS NO.	005

Block No.	Ref. No.	Note	Part No.	Description	Reqd. QTY			Serial No.	Parts catalogue code
					(1)	(2)	(3)		

### Features of each type CORRECTED

• Features of each type

Specifications	Type	Model
Crankshaft	25mm Ø Straight	
	25.4mm Ø Straight	
	30mm Ø Straight	
	20mm Ø Spline	
	25.4mm Ø Spline	
	30mm Ø Spline	
	3/16" Tapered	
	1/5" Tapered	
Air cleaner	Silent	
	Oil bath	
	Cyclone	
	Generator	
	Standard	
Muffler	Standard	
	Silent	
Spark arrester		
Oil alert		
Starter motor		
Reduction		

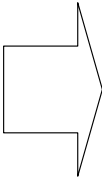

Specifications	Type	Model
Crankshaft	25mm Ø Straight	
	25.4mm Ø Straight	
	30mm Ø Straight	
	20mm Ø Spline	
	1" Thread	
	30mm Ø Spline	
	3/16" Tapered	
	1/5" Tapered	
Air cleaner	Silent	
	Oil bath	
	Cyclone	
	Generator	
	Standard	
Muffler	Standard	
	Silent	
Spark arrester		
Oil alert		
Starter motor		
Reduction		

NOTE A:PART NO. CHANGE D:NEWLY PROVIDED E:PART NO. DELETION K:REQUIRED NO. CORRECTION L:APPLICATION SERIAL NO. CORRECTION  
T:APPLICATION CORRECTION Z:REMARKS CHANGE



PARTS CATALOGUE NEWS

BOOKNo. : 17ZE30E9

Block No.	Ref. No.	Note	Part No.	Description	Reqd. QTY			Serial No.	Parts catalogue code
					GX	(1)	(2)		

E-7 CRANKSHAFT

ILLUSTRATION CORRECTED

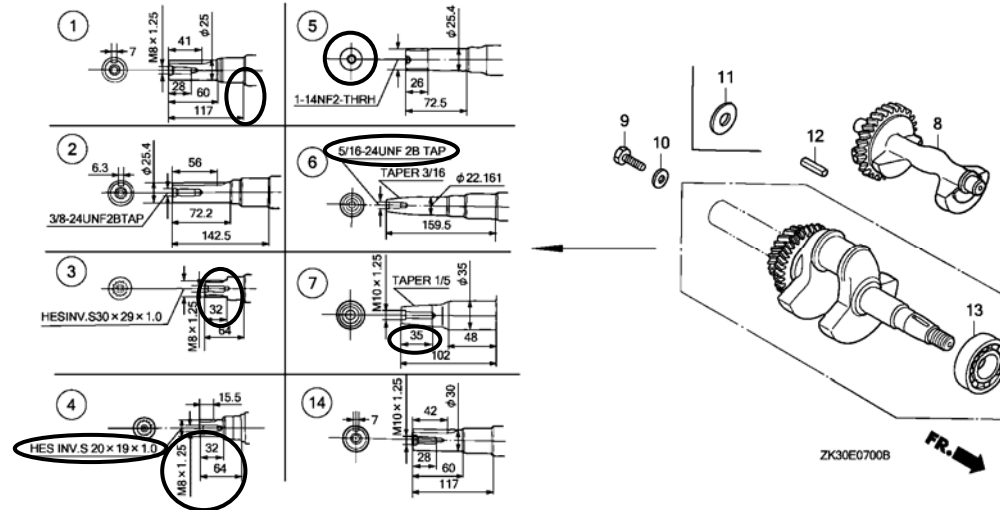

E-16-1	19	T	90013-883-000	BOLT, FLANGE, 6X12(CT200) . . . .	1	-	-	-----	HAQ, HA2, HA2/A, LJS, LJS/A, LJS1, LT, LT/A, LWD, QAC2, QAC2/A, QAE2, QAE2/A, QAE6, QAE6/A, QAG, QAG/A, QAP2, QAP2/A, QAQ, QA2, QA2/A, QA26, QA26/A, QNE2, QNE2/A, QNE6, QNE9, QNE9/A, QNR2, QNR2/A, QNR6, QNR6/A, SKE, SKE/A, VAD2, VAD2/A, VA2, VA2/A, VDE2, VDE2/A, VH12, VH12/A, VH22, VH22/A, VW12, VW12/A
					1	-	-	-----	2644833 HA, QA, QAE, QAP, QNE, QN18, VA, VAH1, VAH2, VAW1, VDE
					-	(1)	-		

NOTE A:PART NO. CHANGE D:NEWLY PROVIDED E:PART NO.DELETION K:REQUIRED NO. CORRECTION L:APPLICATION SERIAL NO. CORRECTION T:APPLICATION CORRECTION Z:REMARKS CHANGE



# PARTS CATALOGUE NEWS

Honda Motor Co., Ltd. Service Division

Printed in Japan

CODE NO.	17ZE30E9
PARTS CATALOGUE NEWS	GX340K1 GX340K1 [PROPANE ENGINE]
NEWS NO.	006

## GX340K1-SKT TYPE sales parts information

**NOTE:** This Parts Catalogue News explains only the parts of the different model that are produced to conform to addition of the GX340K1-SKT type.

As for the parts not listed on this Parts Catalogue News, use the parts of the GX340K1-SKE type.

### •Models, parts catalogue codes and applicable serial numbers

Model	Type		Parts catalogue type	Applicable engine serial No.	Applicable carburetor identification No.
GX340K1	SKE	Base Type	SKE	GC05- 2000001~3599999	BE34B C BE80B B
	SKT	Additional Type	SKT	GC05- 3600001~	BE80B B

•Features of each type		Base type	Additional type
Specifications		GX340K1	
Model		GX340K1	
Type		SKE	SKT
Crankshaft	25 mm Ø Straight	●	●
	25.4 mm Ø Straight		
	30 mm Ø Straight		
	20 mm Ø Spline		
	30 mm Ø Spline		
	3/16" Tapered		
	1/5" Tapered		
	1" Thread		
Air cleaner	Silent	●	●
	Oil bath		
	Cyclone		
	Generator		
	Standard		
Muffler	Standard	●	●
	Silent		
Spark arrester			
Oil alert			
Starter motor		●	●
Reduction			

## PARTS CATALOGUE NEWS

BOOKNo. : 17ZE30E9

Block No.	Ref. No.	Part No.	Description	Reqd. QTY			Base Part No.	Parts catalogue code	
				(1)	(2)	(3)			
E-2	1	12200-ZF6-406	HEAD COMP., CYLINDER .....	1	-	-	12200-ZF6-W01		
	5	12251-ZE3-W01	GASKET, CYLINDER HEAD .....	1	-	-	12251-ZE3-W00		
	18	95701-10080-00	BOLT, FLANGE, 10X80 .....	4	-	-	95725-10080-00		
E-3	1	12000-ZE3-418	BARREL ASSY., CYLINDER (SELF-STARTER)	1	-	-	12000-ZE3-838		
	10		PLUG, SEALING (RUBBER 10MM) ..	0	-	-	90801-ZE2-003		
E-6	18		WASHER, 6X16 .....	0	-	-	90473-147-000		
E-7	1	13310-ZE3-020	CRANKSHAFT COMP. ....	1	-	-	13310-ZE3-010		
E-8	1		RING SET, PISTON (STD.) (NIPPON)	0	-	-	13010-ZE3-003		
			RING SET, PISTON (0.25) (NIPPON)	(0)	-	-	13011-ZE3-003		
			RING SET, PISTON (0.50) (NIPPON)	(0)	-	-	13012-ZE3-003		
			RING SET, PISTON (0.75) (NIPPON)	(0)	-	-	13013-ZE3-003		
		13010-Z5L-004	RING SET, PISTON (STD.) (TEIKOKU)	1	-	-	13010-ZE3-005		
		13011-Z5L-004	RING SET, PISTON (0.25) (TEIKOKU)	(1)	-	-	13011-ZE3-005		
		13012-Z5L-004	RING SET, PISTON (0.50) (TEIKOKU)	(1)	-	-	13012-ZE3-005		
		13013-Z5L-004	RING SET, PISTON (0.75) (TEIKOKU)	(1)	-	-	13013-ZE3-005		
		2	13101-ZE3-W01	PISTON (STD.) .....	1	-	-	13101-ZE3-W00	
			13102-ZE3-W01	PISTON (0.25) .....	(1)	-	-	13102-ZE3-W00	
			13103-ZE3-W01	PISTON (0.50) .....	(1)	-	-	13103-ZE3-W00	
			13104-ZE3-W01	PISTON (0.75) .....	(1)	-	-	13104-ZE3-W00	

## PARTS CATALOGUE NEWS

BOOKNo. : 17ZE30E9

Block No.	Ref. No.	Part No.	Description	Reqd. QTY			Base Part No.	Parts catalogue code
				(1)	(2)	(3)		
E-11	1	28400-ZE3-W02ZP	STARTER ASSY., RECOIL *R280*..... POWER RED	1	-	-	28400-ZE3-W01ZA	
	2	28410-ZE3-W01ZP	CASE COMP., RECOIL STARTER *R280*..... POWER RED	1	-	-	28410-ZE3-W01ZA	
	10	28461-ZE2-W03	GRIP, STARTER .....	1	-	-	28461-ZE2-W02	
E-12	3		COVER COMP., FAN *R8*..... BRIGHT RED	0	-	-	19610-ZE3-010ZA	
		19610-ZE3-010ZL	*R280*..... POWER RED	1	-	-		
E-15	6	17235-ZH9-N01	NOSE, SILENCER .....	1	-	-	17235-ZH9-N00	
E-16-1	3	18320-ZE3-W02	PROTECTOR COMP., MUFFLER .....	1	-	-	18320-ZE3-W01	
	6	18331-ZE3-811	CAP, MUFFLER .....	1	-	-	18331-ZE3-810	
	11	18381-ZE2-801	GASKET, MUFFLER (NIPPON LEAKLESS)	1	-	-	18381-ZE2-800	
E-17	3	17500-ZE3-813ZA	TANK ASSY., FUEL (GAUGE) *NH31*..... MCKINLEY WHITE	1	-	-	17500-ZE3-811ZA	
	7		CAP COMP., FUEL FILLER (BLACK)	0	-	-	17620-ZH7-023	
	8		PACKING, FUEL FILLER CAP (39X58X3)	0	-	-	17631-ZH7-003	
	29	17620-Z0T-305	CAP COMP., FUEL FILLER (CHROME PLATED)	1	-	-		
	30	17631-Z0T-812	PACKING, FUEL FILLER CAP (39X62X3) (TOUYOUSYA)	1	-	-		
E-19	3	28450-ZE3-W11	PULLEY COMP., STARTER (SCREEN GRID)	1	-	-		
	4		PULLEY, STARTER .....	0	-	-	28451-ZE3-W01	
	9	90201-ZE3-790	NUT, SPECIAL, 16MM .....	1	-	-	90201-ZE3-V00	
E-20-2	2	30500-ZF6-W03	COIL ASSY., IGNITION .....	1	-	-	30500-ZE2-023	
	12	31630-ZE1-013	COIL ASSY., CHARGE (1A) .....	1	-	-	31630-ZE1-003	
E-21	4	31210-ZE3-023	MOTOR UNIT, STARTER .....	1	-	-	31210-ZE3-013	

PARTS CATALOGUE NEWS

BOOKNo. : 17ZE30E9

Block No.	Ref. No.	Part No.	Description	Reqd. QTY			Base Part No.	Parts catalogue code
				(1)	(2)	(3)		
E-23-1	1	31610-ZE3-013ZD	BOX ASSY., CONTROL (INTERNAL) *R280*.....POWER RED	1	-	-	31610-ZE3-013ZB	
	4	31615-ZE3-003ZE	PANEL COMP., CONTROL *R280*.....POWER RED	1	-	-	31615-ZE3-003ZB	
	8	35100-ZE2-033	SWITCH ASSY., COMBINATION ....	1	-	-	35100-ZE2-023	
	9	35111-880-013	KEY COMP. ....	2	-	-	35111-880-003	
	13	87529-ZE2-020	PANEL, CONTROL BOX (INTERNAL)	1	-	-	87529-ZE2-010	

E-28-1 LABEL (2)

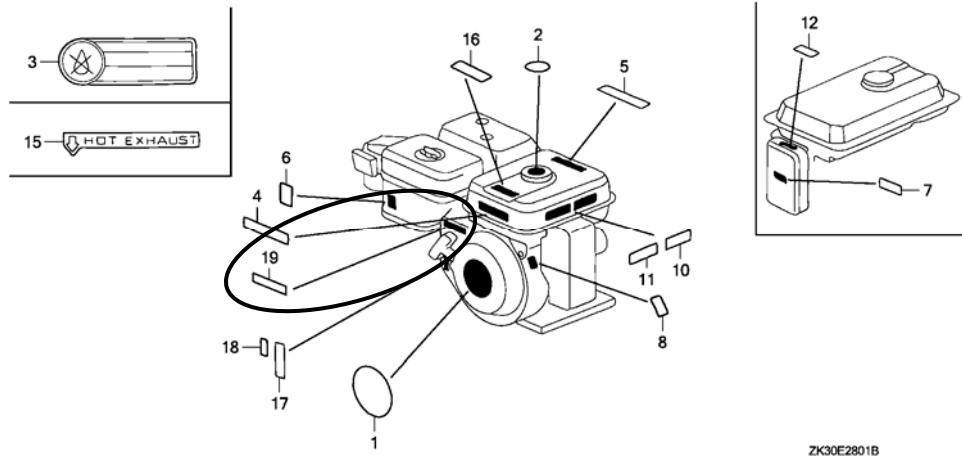

ZK30E2801B

E-28-1	1	87521-ZE3-W04	EMBLEM (GX340) .....	1	-	-	87521-ZE3-W02	
	8		LABEL, SPECIFICATION .....	0	-	-	87530-ZE3-W01	
	17		LABEL, E-SPEC (EPA STANDARD) (15.5X60.0)	0	-	-	87135-ZE2-010	
	18	87114-ZH7-000	LABEL, WARNING (NOT CERTIFIED FOR SALE)	1	-	-		
	19	87532-ZH8-W40	MARK, THROTTLE INDICATION ....	1	-	-		

PARTS CATALOGUE NEWS

BOOKNo. : 17ZE30E9

Block No.	Ref. No.	Part No.	Description	Reqd. QTY			Base Part No.	Parts catalogue code
				(1)	(2)	(3)		
E-29-2	7	89219-805-000	HANDLE, BOX WRENCH .....	1	-	-		



# PARTS CATALOGUE NEWS

Honda Motor Co., Ltd. Service Division

## PARTS CATALOGUE - CORRECTED

Printed in Japan

CODE NO.	17ZE30E9
PARTS CATALOGUE NEWS	GX340K1 GX340K1 [PROPANE ENGINE]
NEWS NO.	007

Block No.	Ref. No.	Note	Part No.	Description	Reqd. QTY			Serial No.	Parts catalogue code
					(1)	(2)	(3)		
E-11	1	L	28400-ZE3-W01ZP	STARTER ASSY., RECOIL *R280*.....POWER RED	1	-	-	-----	EDK, EDS4, PXA2, VSH7, VXK
					1	-	-	-----	4142904 EDT3, LJS1, VMQ
					1	-	-	3658030	----- PKX2
					1	-	-	3662094	----- EDE2/A, ED6/A, ED8/A, EMT/A, ENT/A, HA2/A, HX26/A, LH/A, LHB3/A, LHB5, LHE/A, LHQ4/A, LT/A, LX/A, LXE/A, LXE2/A, LXE4/A, LXE8/A, LXQ4/A, LXU/A, LX2/A, LX26/A, PKT2/A, PKT4/A, PKX4/A, PX/A, PXE8/A, QAB2/A, QAC2/A, QAE2/A, QAE6/A, QAG/A, QAH2/A, QAP2/A, QA2/A, QA26/A, QE/A, QHB3/A, QHB5, QHE/A, QHP1/A, QHQ4/A, QKA4/A, QME0/A, QME8/A, QMH/A, QMT2/A, QNE2/A, QNE9/A, QNR2/A, QNR6/A, QP/A, QT/A, QTC2/A, QWH2/A, QX/A, QXB/A, QXB7/A, QXC/A, QXC4/A, QXC6/A, QXC9/A, QXE/A, QXE4/A, QXE6/A, QXE8/A, QXQ4/A, QXU/A, SE/A, SH/A, SHB3/A, SHQ4/A, SME0/A, SMX2/A, STP/A, STQ/A, SWX/A, SX/A, SXB/A, SXB7/A, SXEB/A, SXE4/A, SXE8/A, SXQ4/A, SXU/A, VAD2/A, VA2/A, VC2/A, VDE2/A, VH12/A, VH22/A, VMT/A, VW12/A, VX/A, VXB/A, VXB7/A, VXE/A, VXEB/A, VXE2/A, VXE7/A, VXE8/A, VXQ4/A, VXU/A, VXU1/A, VX16/A, VX8/A
					1	-	-	3662094 4142904	EDS1/A, EDT1/A, ED9/A, ES1/A, ES3/A, ES4/A, LJ/A, LJG/A, LJS/A, QH/A, SJ/A, SJG/A, SKE/A, SKZ/A, STJ/A, SXE/A
					-	(1)	-	3663625	----- P1/A, Q1/A
					-	(1)	-	3663625 4142904	L1/A, S1/A

NOTE A:PART NO. CHANGE D:NEWLY PROVIDED E:PART NO. DELETION K:REQUIRED NO. CORRECTION L:APPLICATION SERIAL NO. CORRECTION  
T:APPLICATION CORRECTION Z:REMARKS CHANGE



PARTS CATALOGUE NEWS

BOOKNo. : 17ZE30E9

Block No.	Ref. No.	Note	Part No.	Description	Reqd. QTY			Serial No.	Parts catalogue code
					(1)	(2)	(3)		
		T	28400-ZE3-W02ZP	*R280* . . . . . POWER RED	1	(1)	-	4142905 -----	EDS1/A, EDT1/A, EDT3, ED9/A, ES1/A, ES3/A, ES4/A, LJ/A, LJG/A LJS/A, LJS1, L1/A, QH/A, SJ/A, SJG/A, SKE/A, SKT, SKZ/A, STJ/A SXE/A, S1/A, VMQ
E-40-4	1		28400-ZE3-W01ZP	STARTER ASSY., RECOIL *R280* . . . . . POWER RED	1	-	-	----- 4142904	ES2
		A	28400-ZE3-W02ZP	*R280* . . . . . POWER RED	1	-	-	4142905 -----	ES2

NOTE A:PART NO. CHANGE D:NEWLY PROVIDED E:PART NO. DELETION K:REQUIRED NO. CORRECTION L:APPLICATION SERIAL NO. CORRECTION  
T:APPLICATION CORRECTION Z:REMARKS CHANGE



# PARTS CATALOGUE NEWS

Honda Motor Co., Ltd. Service Division

## PARTS CATALOGUE - CORRECTED

Printed in Japan

CODE NO.	17ZE30E9
PARTS CATALOGUE NEWS	GX340K1 GX340K1 [PROPANE ENGINE]
NEWS NO.	008

Block No.	Ref. No.	Note	Part No.	Description	Reqd. QTY			Serial No.	Parts catalogue code
					(1)	(2)	(3)		
E-17	2	T	16955-ZE1-000	JOINT, FUEL TANK .....	1	-	-	-----	BJ, EDK, ED7, ED8, ED8/A, ED9, ED9/A, ES, ES1, ES1/A, ES2, HA HAQ, HA2, HA2/A, HH, HX, HX2, HX26, HX26/A, LH, LH/A, LHB1, LHB3 LHB3/A, LHB5, LHC, LHE, LHE/A, LHQ4, LHQ4/A, LHW, LJ, LJ/A, LJG LJG/A, LJS, LJS/A, LJS1, LKE, LKE/A, LP, LSX, LT, LT/A, LWD LWD1, LWD1/A, LX, LX/A, LXE, LXE/A, LXE2, LXE2/A, LXE4, LXE4/A LXE6, LXE8, LXE8/A, LXQ4, LXQ4/A, LXU, LXU/A, LXZ, LX2, LX2/A LX26, LX26/A, PKT2, PKT2/A, PKT4, PKT4/A, PKX2, PKX4, PKX4/A PX, PX/A, PXA2, PXE8, PXE8/A, QA, QAB2, QAB2/A, QAE, QAE2 QAE2/A, QAE6, QAE6/A, QAG, QAG/A, QAH2, QAH2/A, QAP, QAPE QAP2, QAP2/A, QAQ, QA2, QA2/A, QA26, QA26/A, QDW9, QDW9/A, QE QE/A, QH, QH/A, QHB3, QHB3/A, QHB5, QHC, QHE, QHE/A, QHP1 QHP1/A, QHQ4, QHQ4/A, QH2, QKA4, QKA4/A, QL2, QME0, QME0/A QME8, QME8/A, QMH, QMH/A, QMT2, QMT2/A, QMX2, QNE, QNE2 QNE2/A, QNE6, QNE9, QNE9/A, QNR2, QNR2/A, QNR6, QNR6/A, QN18 QP, QP/A, QPE2, QT, QT/A, QTC2, QTC2/A, QWH2, QWH2/A, QX, QX/A QXB, QXB/A, QXB7, QXB7/A, QXC, QXC/A, QXC4, QXC4/A, QXC6 QXC6/A, QXC9, QXC9/A, QXE, QXE/A, QXEB, QXE2, QXE4, QXE4/A QXE6, QXE6/A, QXE8, QXE8/A, QXQ4, QXQ4/A, QXU, QXU/A, QX2, SDE SE, SE/A, SH, SH/A, SHB1, SHB3, SHB3/A, SHE, SHEZ, SHQ4, SHQ4/A SJ, SJ/A, SJG, SJG/A, SKE, SKE/A, SKZ, SKZ/A, SME0, SME0/A SME2, SMX2, SMX2/A, STJ, STJ/A, STP, STP/A, STQ, STQ/A, SWX SWX/A, SX, SX/A, SXB, SXB/A, SXB7, SXB7/A, SXE, SXE/A, SXEB SXEB/A, SXE2, SXE4, SXE4/A, SXE8, SXE8/A, SXP, SXQ4, SXQ4/A SXU, SXU/A, VA, VA2, VA2/A, VD16, VE, VEB6, VH, VHE, VMX, VX VX/A, VXB, VXB/A, VXB2, VXB7, VXB7/A, VXE, VXE/A, VXEB, VXEB/A VXE2, VXE2/A, VXE4, VXE6, VXE7, VXE7/A, VXE8, VXE8/A, VXG, VXG VXQ4, VXQ4/A, VXU, VXU/A, VXU1, VXU1/A, VX16, VX16/A, VX8 VX8/A, YJ

- (1) -

NOTE A:PART NO. CHANGE D:NEWLY PROVIDED E:PART NO.DELETION K:REQUIRED NO. CORRECTION L:APPLICATION SERIAL NO. CORRECTION  
T:APPLICATION CORRECTION Z:REMARKS CHANGE

PARTS CATALOGUE NEWS

BOOKNo. : 17ZE30E9

Block No.	Ref. No.	Note	Part No.	Description	Reqd. QTY			Serial No.	Parts catalogue code
					(1)	(2)	(3)		
		D	16955-ZE1-010	.....	1	-	-	-----	SKT

NOTE A:PART NO. CHANGE D:NEWLY PROVIDED E:PART NO.DELETION K:REQUIRED NO. CORRECTION L:APPLICATION SERIAL NO. CORRECTION  
T:APPLICATION CORRECTION Z:REMARKS CHANGE